

**HEAT EXCHANGER FOULING MITIGATION BY BLENDING  
AND ULTRASONIC**

by

**Muhammad Zulhaziman Bin Mat Salleh**

**8968**

Dissertation submitted in partial fulfilment of  
the requirements for the  
Bachelor of Engineering (Hons)  
(Chemical Engineering)

JULY 2010

Universiti Teknologi PETRONAS  
Bandar Seri Iskandar  
31750 Tronoh  
Perak Darul Ridzuan

CERTIFICATION OF APPROVAL

**Heat Exchanger Fouling Mitigation By Blending and Ultrasonic**

by

Muhammad Zulhaziman Bin Mat Salleh

A project dissertation submitted to the  
Chemical Engineering Programme  
Universiti Teknologi PETRONAS  
in partial fulfilment of the requirement for the  
BACHELOR OF ENGINEERING (Hons)  
(CHEMICAL ENGINEERING)

Approved by,



(Assoc. Prof. Dr Hilmi Bin Mukhtar)

UNIVERSITI TEKNOLOGI PETRONAS

TRONOH, PERAK

July 2010

This is to certify that I am responsible for the work submitted in this project, that the original work is my own except as specified in the references, and that the original work contained herein have not been undertaken or done by unspecified sources or persons.

A handwritten signature in black ink, appearing to read 'Muhammad Zulhaziman Bin Mat Salleh', written over a horizontal line.

MUHAMMAD ZULHAZIMAN BIN MAT SALLEH

## ABSTRACT

Fouling is a major economic problem faced in petroleum industry. The presence of paraffin wax deposition causes ineffective heat transfer and cost increment, since it creates a new resistance to the heat flow. Many people keeps thinking and moving forward in their effort to reduce the fouling, which encourages them to focus on the mitigation and cleaning techniques. The objective of this study is to investigate the fouling characteristics of pure and mixed crude oil on heat exchanger surface. In addition, the study also investigated the effect of ultrasonic application for fouling mitigation. The specified parameters were varied in each set of experiment, followed by monitoring the rate of deposition for 3 hours. The experiments were mainly carried out using cold finger unit, cooling bath circulation system and ultrasonic bath unit. Besides, the effects of each run were observed by varying 3 different crude oil samples (TAPIS, MASSA and MIRI), wall temperatures, crude oil temperatures and ultrasonic application. Ultrasonic wave was generated at the lowest frequency (28kHz) and highest power (600W), since this condition is proved to give the highest mitigation. The result shows that the deposition increases as times increases. In addition, deposition favors at low crude oil and wall temperature, because it depends on the temperature differences and amount of crude oil temperature below the cloud point. Apart from that, it was found that the amount of deposition is directly dependant to the amount of paraffin wax in each sample. However, after introducing the blending options, deposition of higher paraffin wax content sample was lowered down because the wax content has been reduced. Finally, the combination of ultrasonic and blending was proved to give very high and effective reduction of deposition for all samples namely TAPIS-MASSA (50%), MASSA-MIRI (50%) and TAPIS-MIRI (60%). In short, crude oil blend and ultrasonic application were proved as an effective method of fouling mitigation.

## **ACKNOWLEDGEMENT**

First and foremost, I would like to express my utmost gratitude to Allah SWT for guiding me along this project. Alhamdulillah, all praise to Allah for ensuring successful flow of my Final Year Project (FYP). Next, I would also like to express my deep appreciation to my excellent supervisor, Assoc. Prof. Dr Hilmi Bin Mukhtar, Director of Undergraduate Studies in Universiti Teknologi PETRONAS (UTP). He has given me a lot of motivations, advices and meaningful supports throughout this one year of FYP. Thanks a lot for sharing and guiding me especially on how to conduct an experimental research project. Apart from that, the special credit goes to my beloved father, Mat Salleh Bin Othman, and mother, Khaziah Binti Jusoh. They had given a lot of inspiration and words of wisdom which is putting me through all hurdles led to this achievement. Next, I also would like to forward my appreciation to Mr Sakib, a very kind and polite postgraduate student for helping me a lot during conducting experiments in Block P. Lastly, special thanks are dedicated to my beloved course mates and friends whose had contributed a great help directly or indirectly. Everyone has been very helpful to me in their own way that could produce what I am right now. This FYP certainly is hard to be accomplished without the helps from everyone above. Thank you.

# TABLE OF CONTENT

<b>ABSTRACT.....</b>	<b>i</b>
<b>ACKNOWLEDGEMENT.....</b>	<b>ii</b>
<b>TABLE OF CONTENT.....</b>	<b>iii</b>
<b>LIST OF FIGURES &amp; TABLE.....</b>	<b>iv</b>
<b>CHAPTER 1: INRODUCTION.....</b>	<b>1</b>
1.1 <i>Background of Study.....</i>	1
1.2 <i>Problem Statement.....</i>	3
1.3 <i>Objectives.....</i>	3
1.4 <i>Scope of Study.....</i>	4
<b>CHAPTER 2: LITERATURE REVIEW.....</b>	<b>5</b>
2.1 <i>Heat Exchanger Fouling.....</i>	5
2.2 <i>Fouling Mitigation and Cleaning Technique.....</i>	8
2.3 <i>Crude Oil Blending.....</i>	9
2.4 <i>Ultrasonic.....</i>	10
2.5 <i>Crude Oil Sample.....</i>	16
<b>CAHPTER 3: METHODOLOGY.....</b>	<b>17</b>
3.1 <i>Research Methodology.....</i>	17
3.2 <i>Project Activity/Key Milestone.....</i>	17
3.3 <i>Experimental Equipments.....</i>	19
3.4 <i>Gantt Chart.....</i>	23
<b>CHAPTER 4: RESULT AND DATA ANALYSIS.....</b>	<b>24</b>
4.1 <i>Deposition of Pure Crude Oils.....</i>	24
4.2 <i>Effect of Crude Oil Temperature and Wall Temperature.....</i>	25
4.3 <i>Blending Effect.....</i>	27
4.4 <i>Effect of Ultrasonic Wave.....</i>	28
<b>CHAPTER 5: CONCLUSION.....</b>	<b>30</b>
<b>REFERENCES.....</b>	<b>31</b>

## LIST OF FIGURES & TABLES

<i>Figure 2.1: Crude Oil Blending</i>	12
<i>Figure 2.2: The concept of ultrasonic cavitations.</i>	14
<i>Figure 2.3: Ultrasonic Speeds the Cleaning by Dissolution</i>	15
<i>Figure 2.4: Ultrasonic Activity Displaces Particles</i>	16
<i>Figure 3.1: The schematic diagram of cold finger unit</i>	23
<i>Figure 3.2: Cold Finger Unit</i>	23
<i>Figure 3.3: The dimension/schematic diagram of ultrasonic bath setup</i>	24
<i>Figure 3.4: Ultrasonic Wave experimental set up</i>	24
<i>Figure 3.5: Gantt Chart for FYP</i>	26
<i>Figure 3.6 : Gantt Chart for FYP 2</i>	26
<i>Figure 4.1: Deposition rate of pure crude oil samples.</i>	27
<i>Figure 4.2: Mass of deposit (g) vs. time (min) for constant wall temperature</i>	28
<i>Figure 4.3: Mass of deposit (g) vs time (min) for constant crude oil temperature</i>	28
<i>Figure 4.4: Mass of deposit (g) vs time (min) for TAPIS-MASSA blend</i>	30
<i>Figure 4.5: Mass of deposit (g) vs time (min) for MASSA-MIRI blend</i>	30
<i>Figure 4.6: Mass of deposit (g) vs time (min) for TAPIS-MIRI blend</i>	30
<i>Figure 4.7: Mass of deposit vs time for TAPIS-MASSA blend after ultrasonic</i>	32
<i>Figure 4.8: Mass of deposit vs time for MASSA-MIRI blend after ultrasonic</i>	32
<i>Figure 4.9: Mass of deposit vs time for TAPIS-MIRI blend after ultrasonic</i>	32
<i>Table 2.1: Properties of Malaysian Crude Oil</i>	19
<i>Table 2.2: Properties of three crude oil samples</i>	19

# CHAPTER 1

## INTRODUCTION

### 1.1 Background of Study

The trend towards process integration in modern plant has given heat exchanger equipment an important role in energy supply. Energy management has become a very crucial mean in any industry involving the heat exchanging equipment. Nowadays, there is virtually no chemical, food processing, pharmaceutical or power generating facility without variety of heat exchangers. For example, heat integration through installation of heat exchanger could reduce the cost of hot and cold utility, by making use of temperature and heat duty of every stream line in the process.

However, the efficiency of heat exchanger is subjected to unavoidable fouling process. Fouling can be caused by organic deposition such as salt, corrosion dirt and chemical compound. In addition, petroleum industry has its own crucial issue regarding the energy management, which is the deposition of oil. Crude oil mainly has a risk of fouling or well known as 'formation damage' by organic deposition inside it such as asphaltenes, wax depositions, paraffin's and/or inorganic deposition such as scale, sand or other solid particles.

The accumulation of deposits in heat exchanger creates new resistance to heat exchange flow and thus reduces heat exchanger efficiency. The deposits cause the decrement of production rate and sometimes require a complete shutdown to perform the offline cleaning. Therefore, offline cleaning creates a huge loss in the production and the economics of the company might not be worth it. Even the current online cleaning technology is widely used such as mechanical or chemical treatments; it is yet costly and sometimes has poor performance.

In petroleum processing, the wax inside the crude oil tends to deposits on the surface of heat exchanger or pipelines. Light crude oil will have lower frequency of fouling, but it is expensive. Therefore, most refineries are driven to purchase greater quantities of lower priced heavy crude oil [Irwin A. Wiehe]. However, heavier crude



oil contains higher concentration of sulphur and naphthenic acids, which leads to higher frequency of refinery fouling. Again this condition contributes to the economic trade off in the selection of crude oil type.

Many types of mitigation technique require detailed information about the exact source of damage in order to decide which technique to conduct. Therefore, efforts have been made to develop new technique with lower application risk. One of these alternatives is the application of sound waves or ultrasound stimulation. Sound waves are generally used in oil industry, specifically in exploration and appraisal during seismic and logging surveys. They are also used in other industries to remove contaminants from other parts or units especially heat exchanger.

Ultrasonic sound wave has a very good ability to remove the particles or deposits in the heat exchanger surfaces. It involves a process known as “ultrasonic cavitations and implosion”. This is accomplished by generating sufficient powerful pulses to overcome the attractive force which holds the particles in place. By this way, the particle will be removed or detached. Cleaning is much faster and possible to clean complex parts. However, the root cause of mitigation is to find the cursor in the oil flowing through the fouled unit. It is essential to accurately characterize the component of the fouling.

## **1.2 Problem Statement**

Fouling in heat exchanger is a common problem in industry. The accumulation of the deposits on the surfaces of heat exchanger creates new resistance to heat transfer, and therefore increases the overall resistance to the heat flow. Consequently, as time goes by and the deposition continues, it will reduce the heat transfer efficiency. Finally, heat exchanger will have to be cleaned before operation can start or continue. Heat exchanger cleaning needs to be planned carefully since it is costly and time consuming. Shutting down the operation just to repair the fouled heat exchanger would give a huge loss. Many types of cleaning has been practiced, however it still does not fully satisfy the economic performance of manufacturer. For example, in mechanical cleaning technique, heat exchanger has to be taken off-line and dismantled in order to remove the deposits manually; hence it is labor intensives. Some cleaning techniques require certain chemicals and less effective. Therefore, the better approach is to mitigate the fouling appropriately with in-situ condition. With respect to this issue, the possibility of in situ mitigation using ultrasonic has been recognized, which could save cost and lessen cleaning time.

## **1.3 Objectives:**

The objectives of this study are as follows:

- 1) To perform experimental analysis for the study of deposition rate on heat exchanger surface using various type of pure crude oil samples.
- 2) To investigate the effect of crude oil blend towards the effort of reducing the deposition.
- 3) To investigate the ability of combining among crude oil blend and ultrasound waves in order to further reduce the deposition.

## **1.4 Scope of Study**

This project is an experimental research study, focusing on the ability of ultrasonic sound waves in mitigating heat exchanger fouling. Ultrasonic wave is known to have advantages in term of cost saving, more effective and consumes lesser time. The scope is narrowed down into an experimental research or laboratory set up, where crude oil blend and ultrasonic wave is used to mitigate the deposition of crude oil on cold finger.

The set of cold finger apparatus will be used in various types of experiments according to the parameters being manipulated i.e. wall temperature, crude oil temperature and deposition time. The running cold water inside the cold finger tube is placed in glassware filled with crude oil in a bath tank. The pattern of wax deposition into the cold finger outer surface is observed and weighed. These experiments use three types of crude oil sample, namely TAPIS, MASSA and MIRI, since the deposition of wax also caused by the properties of crude oil being used. All three samples are expected to have three stages of heaviness and wax composition. After blending experiment, the final task is to apply ultrasonic wave adjacent to the previous experimental set up. The combination of blending and ultrasonic wave is expected to further mitigate the wax deposition indicated by the decrease of wax deposition weight in cold finger surface. The frequency and power of ultrasonic wave is taken as the lowest and highest, respectively, since it will give the highest cleaning effect.

# CHAPTER 2

## LITERATURE REVIEW

### 2.1 Heat Exchanger Fouling

Heat exchanger fouling is described as the accumulation of deposits on the surfaces of heat exchanger which represents a new resistance to the heat flow. The temperature distribution will be affected by the presence of individual fouling layers. Consequently, this deposition increases the overall resistance to the heat flow and reduces the efficiency of the heat exchanger. Fouling continues to be the interest to engineers due to enormous costs associated with the phenomenon. Various estimates put the cost of process side fouling in oil refineries in industrial world alone at 2 billion US dollars a year [1,2].

In general, Epstein [3] has divided fouling into five types namely Chemical Reaction Fouling, Bio-fouling, Crystallization Fouling, Particulate Fouling and Corrosion Fouling. The types of fouling depend on the origin of the precursor [4]. However, in addition, Panchal [5] stated that there is a possible combination of fouling mechanisms which creates another field of study which is known as “interactive fouling”.

In petroleum processing, the most significant issue is the deposition of wax or paraffin into pipeline wall during the transportation. Formation of deposit during petroleum processing has been well studied [6-8]. Apart from that, deposition also occurs at the heat exchanger surface in refinery, especially in the preheat train [9]. However, fouling on the outside of finned tubes can be a more complicated matter, because in extreme situations there is possibility that the thickness of the fouling layer can effectively close off the flow through the fins [10]

#### 2.1.1 *Fouling Mechanism of Crude Oil*

Specifically for the case of crude oil fouling, there are four mechanisms of fouling of heavy organic deposition i.e. Polydispersivity effect, Steric colloidal effect, Aggregation effect and Electrokinetic effect [9]. For the above fouling mechanisms, they generally occur in five consecutive steps [11] as described below.

### *1) Initiation period*

When the new or cleaned heat exchanger has been taken into operation, the initially high heat transfer coefficient may remain unchanged for a certain time. During this time, nuclei for crystallization are formed or nutrients for biological growth are deposited. This delay period may last anytime from few seconds to several days. According to Panchal [5] no delay period occurs for particulate fouling. For crystallization fouling and for chemical reaction fouling, the initiation period decreases with increasing surface temperature, as super saturation and/or reaction rate increase [3]. Generally, it is reported that the delay time, before deposition starts, decreases with increasing roughness of the heat transfer surface.

### *2) Mass Transport*

To form a deposit at the heat transfer surface, it is necessary that at least one key component is transported from the fluid bulk to the heat transfer surface area. In most cases, this occurs by diffusion. For the transport of particles to the wall, inertia effects and thermophoretic forces have to be considered too.

### *3) Formation of Deposit*

After the foulant has been transported to the heat transfer surface, it must stick to the surface (for particulate) or react to the deposit forming substance.

### *4) Removal or Auto-retardation*

Depending on the strength of the deposit, erosion occurs immediately after the first deposition has been laid down. Furthermore, several mechanisms exist, which cause auto-retardation of the deposition process. For the thermal boundary condition of constant temperature difference between heated and cooled fluid, the growth of deposits causes a reduction of the driving temperature difference between heat transfer surface and liquid.

### *5) Ageing*

Every deposit is subjected to ageing. Ageing may increase the strength of the deposits by polymerization, re-crystallization, and dehydration and so on. Biological deposits get poisoned by metal ions and may be washed away by the bulk flow. Ageing is the least investigated and understood step and is usually ignored in modeling attempts [12].

### 2.1.2 *Factors Affecting Fouling*

The most important parameter is the nature of the fluid itself. The propensity of fouling on a heat transfer surface by a given fluid depends upon the following factors [13]:

#### *Effect of Fluid Velocity*

For a given bulk temperature and heat flux, the principal effect of increasing the velocity may be to decrease the fouling rate due to the fact that the heat-transfer coefficient increases and the wall temperature therefore decreases. On the other hand, if the fouling rate is controlled by mass transfer, then the mass transfer coefficient from the bulk to the near-wall region will increase with increasing velocity that resulting in an increase in fouling rate with increasing velocity. A situation in which the fouling rate for a given interface temperature decreases with increasing velocity, the influence of velocity may be manifested in two ways:

- If the deposit is weak, then the shear stress at the wall (which increases with increasing velocity) may give rise to an erosion of the fouling layer which offsets the deposition of the foulant.
- If the foulant material is formed in the fluid boundary layer adjacent to the hot surface (where the formation rate may be highest), then this formed foulant may diffuse back into the bulk fluid. An increase in velocity would increase the rate of mass transfer of the foulant and may reduce the fouling rate.

#### *Effect of heat-transfer surface temperature*

The fluid-foulant interface temperature is a vital parameter affecting the extent of fouling. The bulk fluid temperatures and their heat-transfer coefficients will determine this interface temperature. In hydrocarbon fouling research a frequently used relationship for the effect of surface temperature on fouling rate is of the Arrhenius type.

#### *Material of Construction and surface finish*

Choosing the correct heat-exchanger material is extremely important. A judicious selection will avoid the possibility of corrosion fouling. Some types of biological

fouling can be retarded by using copper-bearing alloys. The roughness, size and density of cavities affect crystalline nucleation, sedimentation and the adherence tendency of deposits. Both of these factors influence fouling initiation rather than the continuation of the fouling process.

## **2.2 Fouling Mitigation and Cleaning Technique**

Fouling mitigation study focuses on obtaining the best mitigation technique to be used in refinery. The purpose is to establish a quantitative measure of success to evaluate and test the preferred mitigation action and make recommendations to the management.

Cleaning of fouled heat exchangers can be performed both on-line and off-line, depending of the process and line-up of the exchanger [11]. Moreover, the particular type of exchanger determines whether the exchanger can be cleaned at all. The tube layout angle also determines if the exchanger can be cleaned on shell side. The cooling-water side of heat exchangers can often be cleaned while the process remains on stream. Either side of a heat exchanger can be cleaned off-stream while the exchanger is by-passed but remains closed. When the heat exchanger is opened the bundle may be removed (type depending) and be cleaned on the spot or taken to a special cleaning area.

### *2.2.1 Online Cleaning*

The on-line cleaning methods can be categorized into chemical and mechanical cleaning:

- Chemical online cleaning – removal of scaling species, pH control, scale inhibitors, anti-oxidants, metal deactivators and dispersants.
- Mechanical on-line cleaning – Reversal of flow direction, gas rumbling, Ultrasound, turbulence promoter, continuous transport of cleaning devices through tubes and gas flow.

### 2.2.2 Off-Line Cleaning

The off-line cleaning methods also divided into two; chemical and mechanical methods. However, chemical methods has the advantages of time saving, surfaces do not experience mechanical damage, less labour intensive and can be performed in-situ.

The chemical methods basically involve five processes which are Alkaline Clean, Rinses, Acid Cleaning, Rinses and Passivation. The most widely used chemical cleaning agents are sulphuric acid and hydrochloric acid [11]

For mechanical cleaning methods, heat exchanger has to be taken off-line and dismantled. Some of the deposits may then be removed manually, for example from the water box. Steam blasting, air pressure and hydro-blasting are the most common mechanical cleaning methods. Garret [14] suggested that if the deposits are very tenacious, sand can be added to the pressurized water to increase the cleaning efficiency.

### 2.3 Crude Oil Blending

Crude oil blending is an attractive solution for refineries. It blends different crude oil types to provide consistent and optimal feedstock to the operation. Blending has advantages such as improves distillation unit throughput, higher value product yield, improves performance of downstream units, improve product quality and reduce energy cost [15].

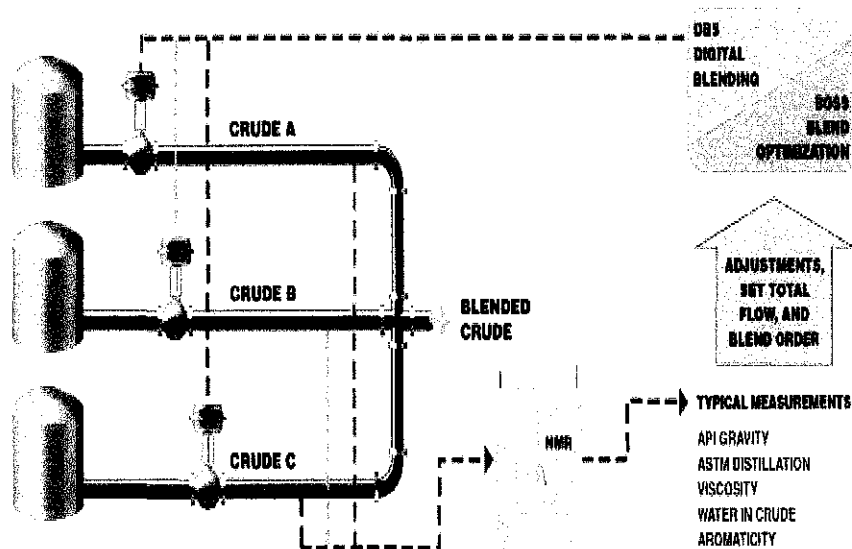

Figure 2.1: Crude Oil Blending



## 2.4 Ultrasonic

### 2.4.1 Definition

Ultrasonics is the science of sound waves above the limits of human audibility. The frequency of a sound wave determines its tone or pitch. Low frequencies produce low or bass tones. High frequencies produce high or treble tones. Ultrasound is a sound with a pitch so high that it can not be heard by the human ear. Frequencies above 18 Kilohertz are usually considered to be ultrasonic. The frequencies used for ultrasonic cleaning range from 20,000 cycles per second or kilohertz (KHz) to over 100,000 KHz. The most commonly used frequencies for industrial cleaning are those between 20 KHz and 50 KHz [16].

### 2.4.2 The theory of sound waves

A sound wave is produced when a solitary or repeating displacement is generated in a sound conducting medium, such as by a “shock” event or “oscillatory” movement. The displacement of air by the cone of a radio speaker is a good example of “oscillatory” sound waves generated by mechanical movement. As the speaker cone moves back and forth, the air in front of the cone is alternately compressed and rarefied to produce sound waves, which travel through the air until they are finally dissipated. We are probably most familiar with sound waves generated by alternating mechanical motion. Another example of a shock event might be the sound created as a wooden board falls with its face against a cement floor. Shock events are sources of a single compression wave which radiates from the source.

### 2.4.3 The Nature of Sound Waves

The compression generated by the sound source as it moves propagates down the length of the spring as each adjacent coil of the spring pushes against its neighbour. Although the wave travels from one end of the spring to the other, the individual coils remain in their same relative positions, being displaced first one way and then the other as the sound wave passes. As a result, each coil is first part of a

compression as it is pushed toward the next coil and then part of a rarefaction as it recedes from the adjacent coil. At a point in the area of a compression, the pressure in the medium is positive. At a point in the area of a rarefaction, the pressure in the medium is negative.

#### 2.4.4 Ultrasonic Cavitation [16]

The cavitation concept which produces microscopic bubbles that collapse, sending out many shock tiny waves, can loosen dirt and other contaminants on metals, plastics or ceramics. Ultrasonic cleaning offers several advantages over conventional methods. Ultrasonic waves generate and evenly distribute cavitation implosion in a liquid medium. The released energies reach and penetrate deep into crevices, blind holes and areas that are inaccessible by other cleaning methods.

In elastic media such as air and most solids, there is a continuous transition as a sound wave is transmitted. In non-elastic media such as water and most liquids, there is continuous transition as long as the amplitude or “loudness” of the sound is relatively low. As amplitude is increased, however, the magnitude of the negative pressure in the areas of rarefaction eventually becomes sufficient to cause the liquid to fracture because of the negative pressure, causing a phenomenon known as cavitation.

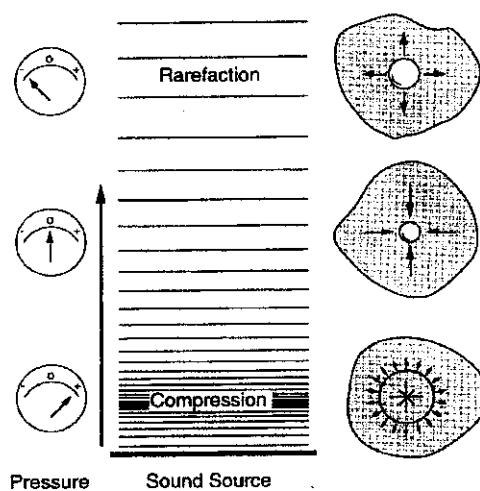
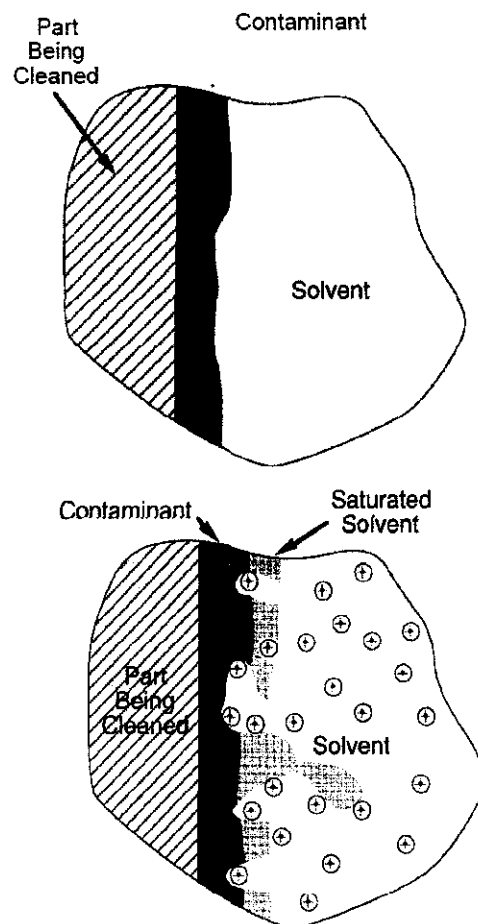

*Figure 2.2: The concept of ultrasonic cavitations.*

Based on Figure 2.2, cavitation “bubbles” are created at sites of rarefaction as the liquid fractures or tears because of the negative pressure of the sound wave in the liquid. As the wave fronts pass, the cavitation “bubbles” oscillate under the influence of positive pressure, eventually growing to an unstable size. Finally, the violent collapse of the cavitation “bubbles” results in implosions.

#### 2.4.5 Ultrasonic Cavitation in Cleaning and Rinsing Process

Cleaning in most instances requires that a contaminant be dissolved (as in the case of a soluble soil), displaced (as in the case of a non-soluble soil) or both dissolved and displaced (as in the case of insoluble particles being held by a soluble binder such as oil or grease). Figure 2.3 illustrates how ultrasonic speeds up the cleaning by dissolution



*Figure 2.3: Ultrasonic Speeds the Cleaning by Dissolution*

Based on Figure 2.3, in removing a contaminant by dissolution, it is necessary for the solvent to come into contact with and dissolve the contaminant. The cleaning activity takes place only at the interface between the solvent and contaminant. As the solvent dissolves the contaminant, a saturated solvent layer develops at the interface between the solvent and the contaminant. Once this has happened, cleaning action stops as the saturated solvent can no longer attack the contaminant. Fresh solvent cannot reach the contaminant. Ultrasonic cavitation and implosion effectively displace the saturated solvent layer to allow fresh solvent to come into contact with the contaminant remaining to be removed. This is especially beneficial when irregular surfaces or internal passageways are to be cleaned.

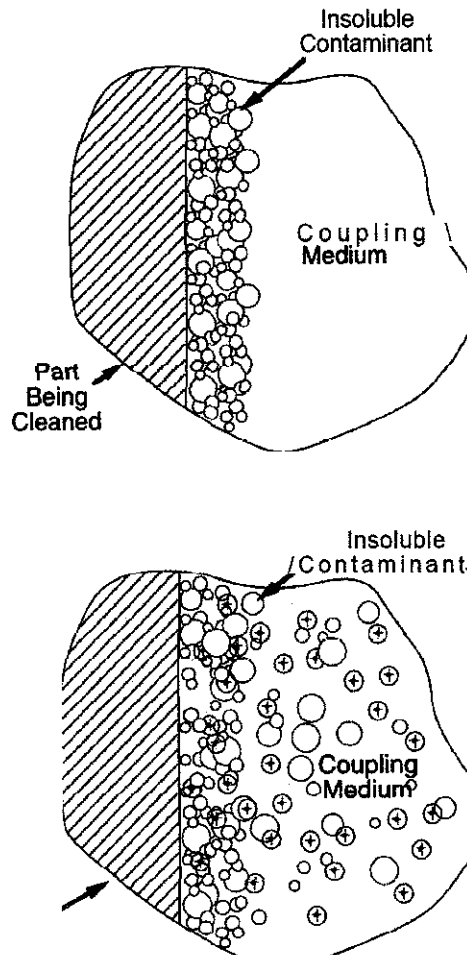

*Figure 2.4: Ultrasonic Activity Displaces Particles*

Figure 2.4 illustrates another ultrasonic reaction which displaces the particles and doing the cleaning. Some contaminants are comprised of insoluble particles loosely attached and held in place by ionic or cohesive forces. These particles need only be displaced sufficiently to break the attractive forces to be removed. Cavitation and implosion as a result of ultrasonic activity displace and remove loosely held contaminants such as dust from surfaces.

#### 2.4.6 Complex Contaminants

Contaminations can also be more complex in nature, consisting of combination soils made up of both soluble and insoluble components. The mechanical micro-agitation helps speed both the dissolution of soluble contaminants and the displacement of insoluble particles. Ultrasonic activity has also been demonstrated to speed or enhance the effect of many chemical reactions. This is caused mostly by the high energy levels created as high pressures and temperatures are created at the implosion sites.

#### 2.4.7 Cavitation Intensity

Cavitation intensity is directly related to Ultrasonic Power at the power levels generally used in ultrasonic cleaning systems. As power is increased substantially above the cavitation threshold, cavitation intensity levels off and can only be further increased through the use of focusing techniques. Cavitation intensity is inversely related to Ultrasonic Frequency. As the ultrasonic frequency is increased, cavitation intensity is reduced because of the smaller size of the cavitation bubbles and their resultant less violent implosion. The reduction in cavitation effect at higher frequencies may be overcome by increasing the ultrasonic power.

The value of viscosity in ultrasonic bath should be low to promote cavitation. The higher the viscosity, the more energy is needed to transmit the ultrasonic pressure wave. Apart from that, the density should also be low. High density liquid requires additional energy to initiate cavitation but create intense cavitation events that further increase the acoustic resistance in transmission of ultrasonic power. Cavitation may not be initiated if the density is too high. Besides, the liquid

temperature also affects the cavitation quality and intensity. The cooler the liquid, the more difficult to go below the point of vaporization to begin cavitation. This is due to the differential between low temperature and the boiling point of the liquid. Increasing the liquid temperature makes it easier to go below the point of vaporization to initiate cavitation with less energy. The number of cavitation events will increase as the temperature is increased but the energy being stored in the cavitation bubble will decrease.

#### 2.4.8 Acoustic Impedance

Cavitation development and amount of energy released relies on a number of factors such as ultrasonic power, density, vapour pressure, operating temperature and the condition of the liquid. These cavitation results in the acoustic impedance value  $Z$ , that affect power being transmitted into liquid volume. There are several factors contributing to the increasing or decreasing of acoustic impedance value that related to liquid medium properties.

Operating frequencies significantly determined the amount of acoustic impedance as it affects the implosion bubble and number of cavitation events. Ultrasonic intensity is an integral function of the frequency and amplitude of the radiating wave. The lower the operating frequency, the larger the implosion bubble and energy release is higher, but the number of cavitation events is reduced. In versa, the higher the frequency, the smaller implosion bubble will be, energy release is lower, but the number of cavitation event increased. As the frequency is increased, the amount of cleaning events is increased and cleaning is more homogenous but less power is released and therefore reduce the cleaning ability.

## 2.5 Crude Oil Sample

This research uses three different types of crude oil samples taken from Malaysia heavy crude. The properties of them are highlighted in the Table 3.1 [17]

*Table 2.1: Properties of Malaysian Crude Oil*

	Assay Date	API	Sulfur wt %	Pour Point Deg C
<b>Malaysian Crude Oil</b>				
<u>Tapis</u>	Nov 2000	44.6	0.028	21
<u>Penara Blend</u>	Oct 2005	37.7	0.0645	36
<u>Bunga Kekwa</u>	May 2002	37.6	0.0451	36
<u>Massa</u>	July 2003	44.3	0.0345	-9
<u>Angsi</u>	Sept 2005	40.17	0.0392	30
<u>Dulang</u>	May 2002	37.2	0.0522	36
<u>Bintulu</u>	Nov 2007	37.67	0.05	-15
<u>Kidurong</u>	Mar 2005	38.2	0.0299	-39
<u>Kikeh</u>	Dec 2007	36.74	0.06	18
<u>Miri Light</u>	Dec 2007	30.79	0.14	3

*Table 2.2: Properties of three crude oil samples*

Properties	MASSa	TAPIS	MIRI
Density @ 15 °C (kg/L)	0.7985	0.8021	0.8692
API Gravity (degrees)	45.7	44.91	31.29
Average Boiling Point (°C)	253.7	256.7	281.7
Average Molecular Weight	220	215	220
Total Sulphur (wt%)	0.034	0.027	0.078
Salt Content (mg/kg)	4.182	46.894	8.278
Nitrogen Content (ppm wt)	220	224	272
Pour Point (°C)	-12	12	-9
Asphaltene (wt%)	0.038	0.039	0.055
Wax (wt%)	6.93	30.67	11.85

# **CHAPTER 3**

## **METHODOLOGY**

### **3.1 Research Methodology**

In order to fulfill the objectives mentioned, the first step is performing the literature review of any current or relevant materials including journals, books, encyclopedias, and articles. One of the aims of this literature review is to identify the equipment and facilities required for this project. It is achieved by referring to the information resources available in Universiti Teknologi PETRONAS (UTP) such as UTP Information Resource Centre (IRC), research officer, lecturers, post graduate students and finally internet resources. This stage was mostly performed in FYP 1.

The next task is to design the experimental investigation plan by identifying all possible combinations available. It is followed by the execution, which is by conducting experiments and documentation of findings/reports. Various types of experiments will be set up to investigate the effectiveness of ultrasonic waves in different depositions or fouling type. This stage was performed in FYP 2.

After all results obtained, they were analyzed accordingly by relating to the theories and again the literature review. The final activity is to prepare the final report and presentation.

### **3.2 Project Activities/Key Milestone**

The student plays an important role as an investigator/researcher with the assist and supervision from the supervisor and collaborators. This project requires a precise monitoring from them, and this could be done through a good communication medium such as weekly meeting, progress report and consultations. The student also might want to visit certain real problem in the industry by visits or review of certain plant and familiarize with the laboratory equipments before running it. Progress reports were submitted according to the schedule to find if there is any corrective action. This was done so that both student and supervisor will have a good and up-to-date communication.



The general activities are categorized as below:

Activity 1: Review of literature for understanding and identify equipment and facilities.

Activity 2: Design experimental investigation plan (identifying all possible combinations)

Activity 3: Conduct experiments and reports.

Activity 4: Analyze the results in each case and report findings

Activity 5: Final Report preparation.

### *3.2.1 Experimental Set Up*

The experiment was divided into two parts; study of deposition rate in three crude oil samples and application of ultrasonic wave into the samples. For every set of experiment, parameters were varied accordingly including wall temperature, crude oil temperature and crude oil blending options. The weights of deposits were recorded as comparison for each set up.

### *3.2.2 Part 1: Crude Oil Deposition Study*

The experiment was conducted using only three Malaysian heavy crude oil samples namely TAPIS, MIRI and MASSA. These three samples are chosen according to the level of quality based on the value of American Petroleum Institute (API), wax content, sulphur content and so on. The decision of these samples is according to the summary of PETRONAS crude oil quality, as shown in Table 2.1

The deposition rate was obtained by measuring the weight of deposit on the cold finger surface for interval of 10 minutes. Temperature of crude oil and cold water was varied to investigate the effect of temperature difference to the deposition rate.

### *3.2.3 Part 2: Crude Oil Blend*

The next part was done to investigate the effect of crude oil blend towards the effort of reducing the deposition on cold finger surface. All blending options were performed with equal volume (50%-50%) as below:

1. 100mL TAPIS + 100mL MASSA
2. 100mL MASSA + 100mL MIRI
3. 100mL TAPIS + 100mL MIRI

### *3.2.4 Part 3: Ultrasonic Mitigation Study*

The experiment was continued with the application of ultrasonic wave into the cold finger system and blending set up to investigate the potential of ultrasonic wave in mitigating the deposition rate. Ultrasonic wave must be applied at optimum condition; therefore it was done at lowest frequency, highest power and the highest mitigation location. Ultrasonic batch set was used to perform this experiment.

## **3.3 Experimental Equipments**

### *3.3.1 Cold Finger*

A cold finger is a piece of laboratory equipment that is used to generate a localized cold surface. It is named for its resemblance to a finger as is a type of cold trap. A schematic of the cold finger devices used in this study is shown in Figure 3.1. Crude oil sample is heated by heating water in heating bath. The surface of cold finger is immersed in heated crude oil, while the inner space of finger is water flowing at desired cool temperature. The water inside the cold finger is cooled by a cooling batch circulation system. This condition creates temperature difference which encourages the precipitation of deposit into the surface of cold finger.

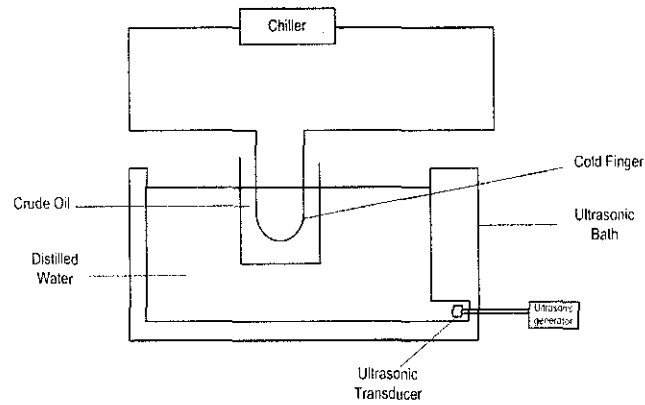

*Figure 3.1: The schematic diagram of cold finger unit*



*Figure 3.2: Cold finger unit*

The steps required in performing cold finger experiment is:

1. The cold finger was weighted and its reading was recorded.
2. 200mL of crude oil was poured into cylinder glassware.
3. The glassware was put inside the water bath and heated to the desired temperature.
4. While the crude oil is being heated, the cold finger was connected to the cooling bath circulation system.
5. The cold finger was immersed into the heated crude oil in cylindrical glassware. The test was performed for duration of 3 hours.
6. The cold finger was taken out and weighted in every 10 minutes to track the deposition progress.

### 3.3.2 Ultrasonic Bath

The ultrasonic bath available in UTP will be used which is SANPA model, multi-frequency ultrasonic cleaner with 600W maximum power, equipped with three available frequencies; 28 kHz, 45 kHz and 100 kHz. The power input is manipulated accordingly at 300 W, 450 W and 600 W. The schematic diagram and experimental set up of ultrasonic bath are shown below:

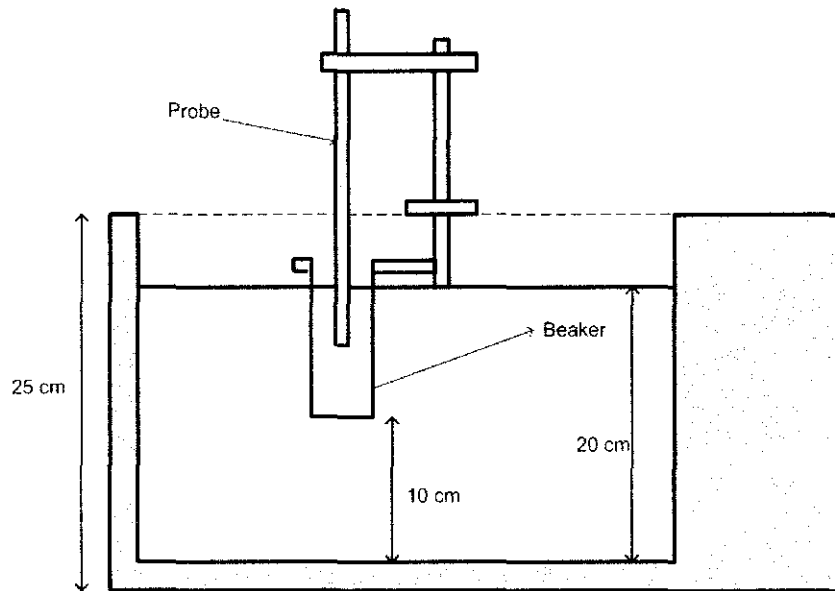

Figure 3.3: The dimension/schematic diagram of ultrasonic bath setup

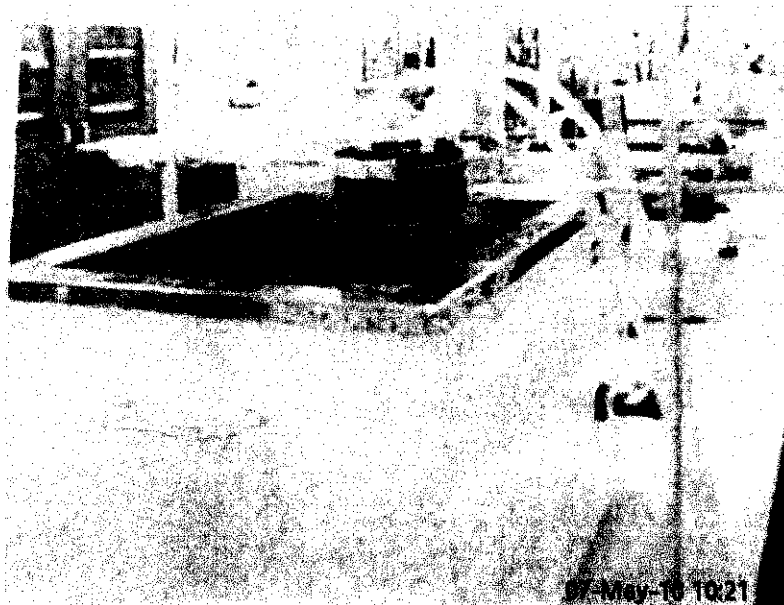

Figure 3.4: Ultrasonic Wave experimental set up

During conducting this experiment, it is necessary to observe the following:

1. The medium of the ultrasonic bath is water, which normally uses distilled water.
2. The pattern of wave depends on the level of water in the ultrasonic bath.
3. Aluminum foil is used for cavitation test. The ultrasonic probe could also be used to measure the ultrasonic power intensity. This is done through mapping. The magnitude of ultrasonic waves will be transferred to the ultrasonic probe software.
4. When testing different types of crude samples, the level of water must be the same for each set of experiment.

The steps involved in conducting ultrasonic experiment are as follows:

1. The cold finger was weighted and its reading was recorded.
2. 200mL of crude oil was poured into cylinder glassware.
3. The glassware was put inside the water bath and heated to the desired temperature.
4. While the crude oil is being heated, the cold finger was connected to the cooling bath circulation system.
5. The frequency of ultrasonic cleaner is set at 28 kHz at maximum power and the start button was pressed.
6. The cold finger was immersed into the heated crude oil in cylindrical glassware. The test was performed for duration of 3 hours.
7. The cold finger was taken out and weighted for every 10 minutes to trace the deposition.

### 3.4 Gantt Chart

The milestone for this project was divided into two parts, specifically FYP 1 and FYP 2. The Gantt chart for both FYP semesters is shown below. In general, FYP 1 dealt with planning, literature review and experimental design. On the other hand, FYP 2 continued the progress by executing the experimental methodology to achieve the objectives mentioned. It was followed by collection, analysis and discussion of results, ended with final report.

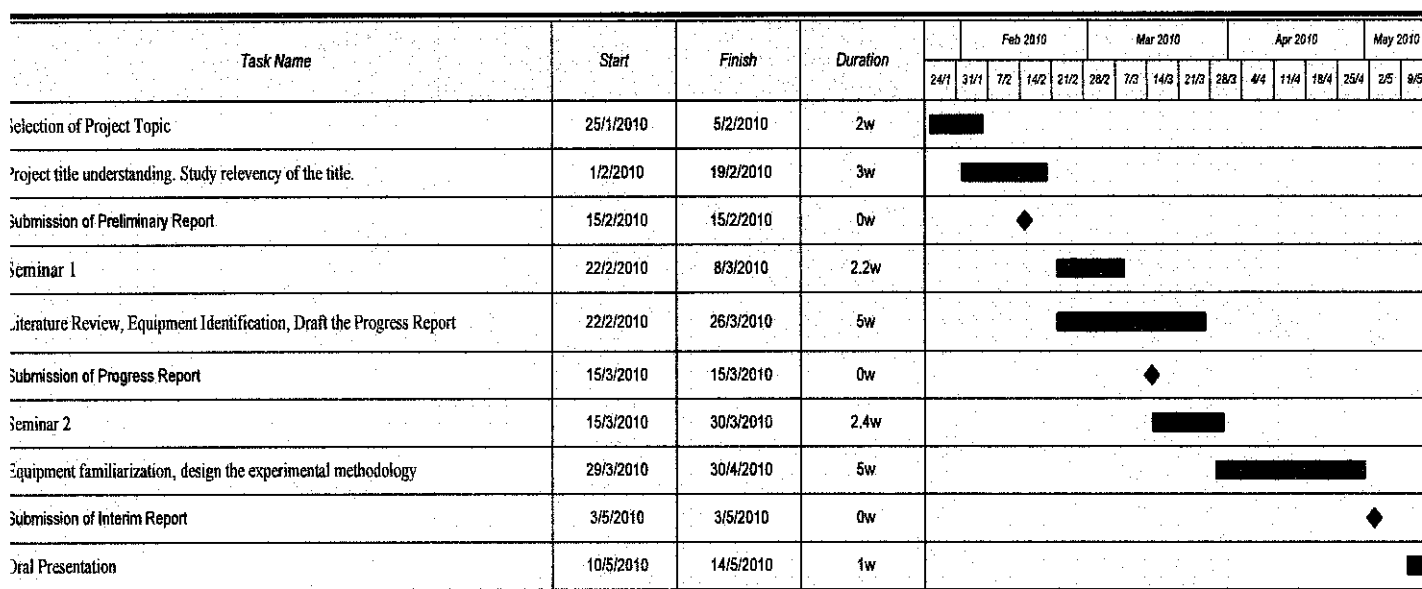

Figure 3.5: Gantt Chart for FYP 1

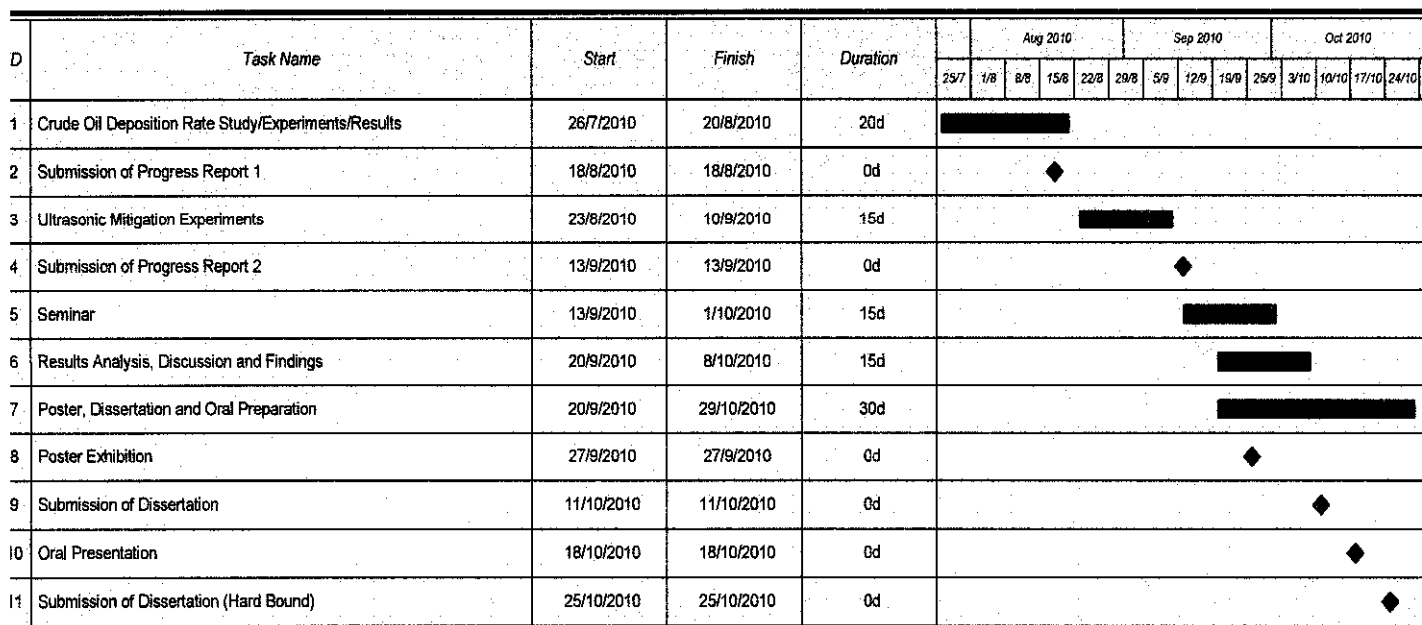

Figure 3.6: Gantt Chart for FYP 2

# CHAPTER 4

## RESULT AND DATA ANALYSIS

### 4.1 Deposition of pure crude oils

As an initial methodology, the first part of the experiment is to investigate the deposition rate for each of the pure samples namely TAPIS, MASSA and MIRI. The experiment was run for 3 hours in cold finger set up bath, while taking the weight reading every 10 minutes. Figure 4.1 below illustrates the deposition rate for each of them:

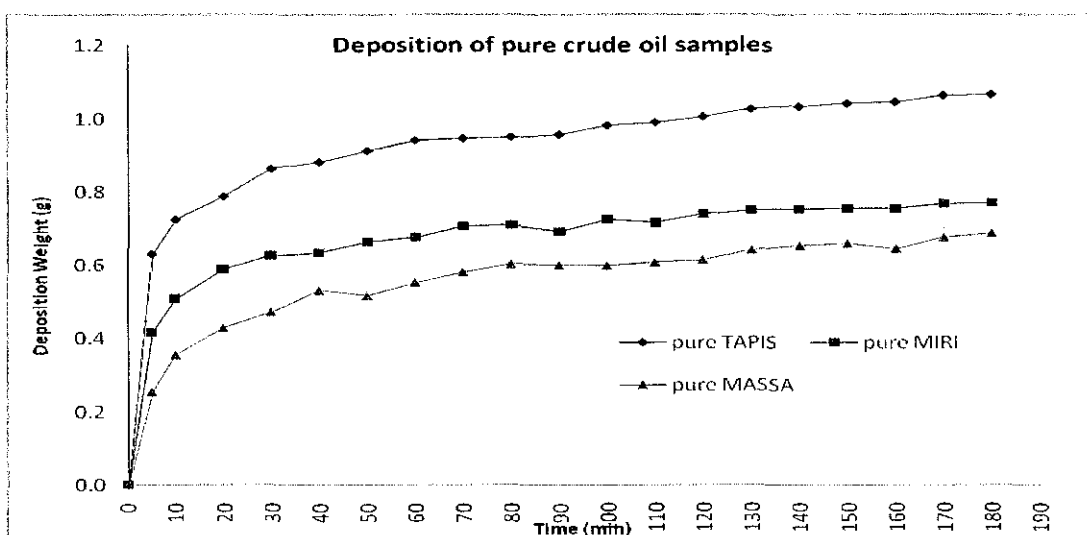

Figure 4.1: Deposition rate of pure crude oil samples.

Based on the figure above, it is observed that TAPIS experienced the highest amount of deposition rate, followed by MIRI and MASSA. This is because TAPIS has the highest amount of paraffin wax as compared to the other two samples, as shown in the literature. The higher wax content, the higher is the amount of wax deposition.

It is also observed that the rate of deposit formation is higher at the initial stage because the slope is steeper, but it is slowly decrease as time goes by. This happens because the deposits which already at the wall will act as insulation layer which reduce the effective differential temperature.

## 4.2 Effect of Crude Oil Temperature and Wall Temperature

Three experiment runs had been done which aims to investigate the effect of crude oil temperature to deposition rate. Figures below illustrate the results and finding.

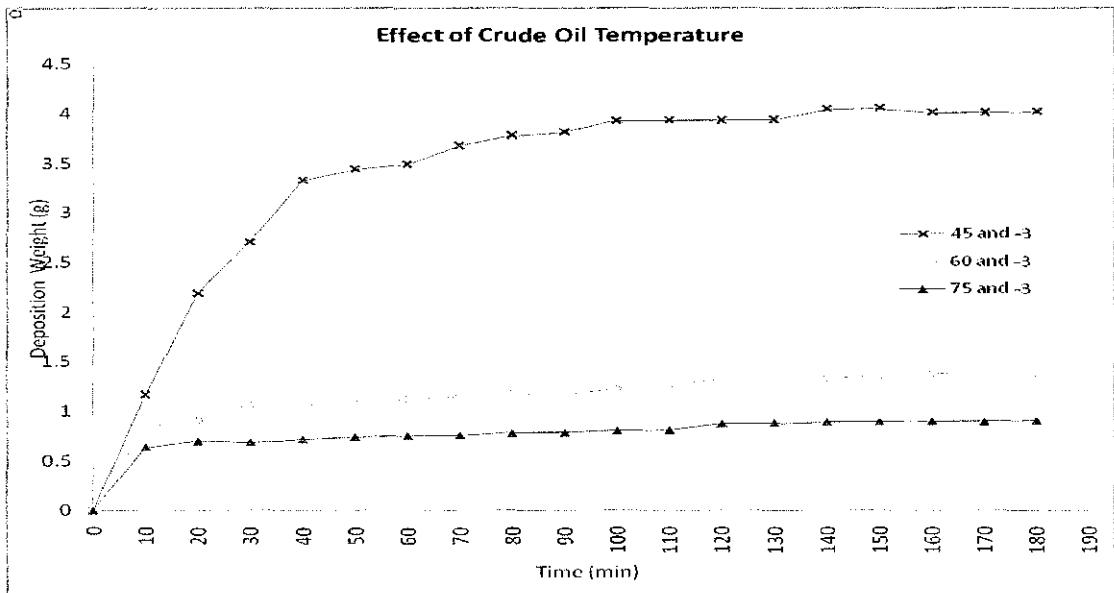

Figure 4.2: Mass of deposit (g) vs. time (min) for constant wall temperature in TAPIS & MIRI blend

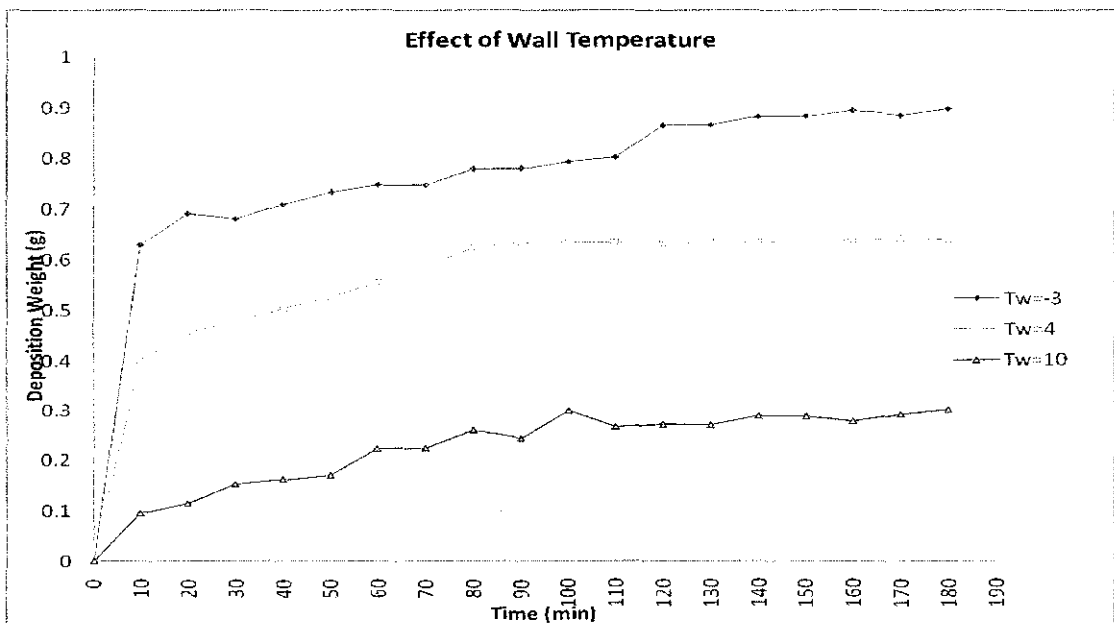

Figure 4.3: Mass of deposit (g) vs time (min) for constant crude oil temperature in TAPIS & MIRI blend



Two types of crude oil sample had been used in blend, namely TAPIS and MIRI. These two samples were chosen because it has the highest wax paraffin combination compared to the other blending options. Both of them have equal volume percentage which is 50%-50% (100mL TAPIS and 100mL MIRI). The wall temperature is set to constant ( $-3^{\circ}\text{C}$ ), while the crude oil is varied into  $45^{\circ}\text{C}$ ,  $60^{\circ}\text{C}$  and  $70^{\circ}\text{C}$ . Each run took 3 hours time. This set up was repeated in the next experiment but with constant crude oil temperature and varied wall temperature.

Based on Figure 4.2 above, it is observed that at  $45^{\circ}\text{C}$ , the deposition weight is higher compared to  $60^{\circ}\text{C}$  and  $75^{\circ}\text{C}$ . Therefore, it is found that the deposition is high at lower crude oil temperature. The highest deposition occurs at the lowest temperature because lower crude oil temperature tends to go more far below the cloud point. Cloud point represents the temperature at which wax or paraffin begins to precipitate from a hydrocarbon solution. It is also generally defined as the temperature at which dissolved solids are no longer completely soluble, precipitating as a second phase giving the fluid a cloudy appearance.

Next, Figure 4.3 illustrates the results and finding in the experiment of varying the wall temperature. In definition, the wall temperature means the temperature of surface of cold finger, which acts as a surface of u-shape tube in heat exchanger. Based on the figure above, it is clearly observed that temperature of  $-3^{\circ}\text{C}$  gives the highest amount of deposition (0.9g at 180min), followed by  $4^{\circ}\text{C}$  and  $10^{\circ}\text{C}$ . The deposit is higher at lower temperature due to the increase of temperature difference between hot and cold. Therefore, the tendency of paraffin wax deposition will be more vigorous.

### 4.3 Blending Effect

The blending of three crude oil samples had been done accordingly. Figure 4.4, Figure 4.5 and Figure 4.6 below show the results in deposition of all three blending options available.

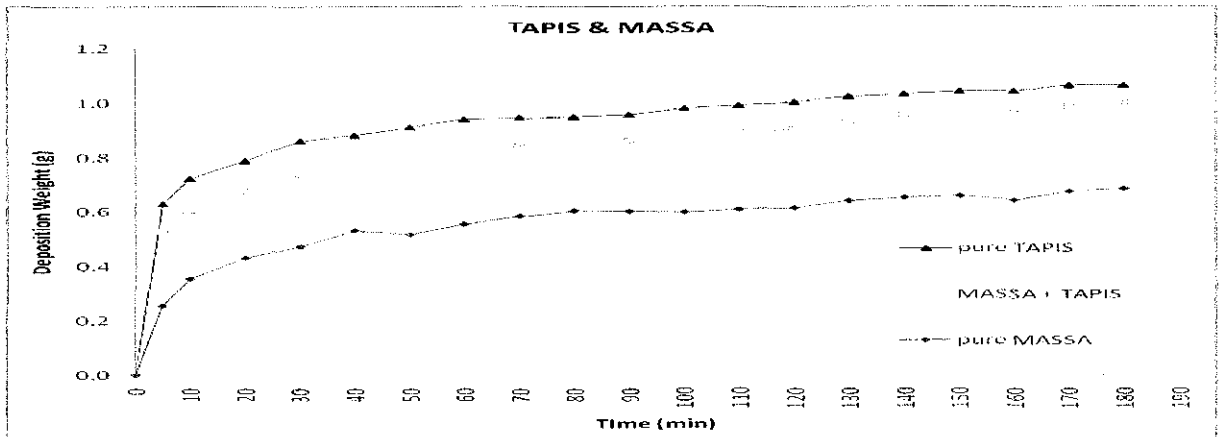

Figure 4.4: Mass of deposit (g) vs time (min) for TAPIS-MASSA blend

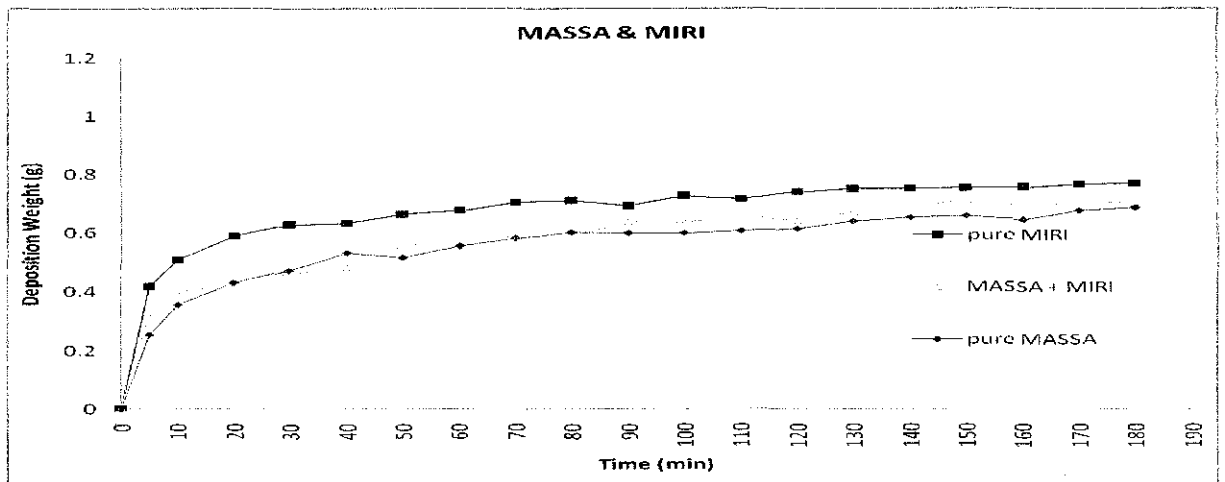

Figure 4.5: Mass of deposit (g) vs time (min) for MASSA-MIRI blend

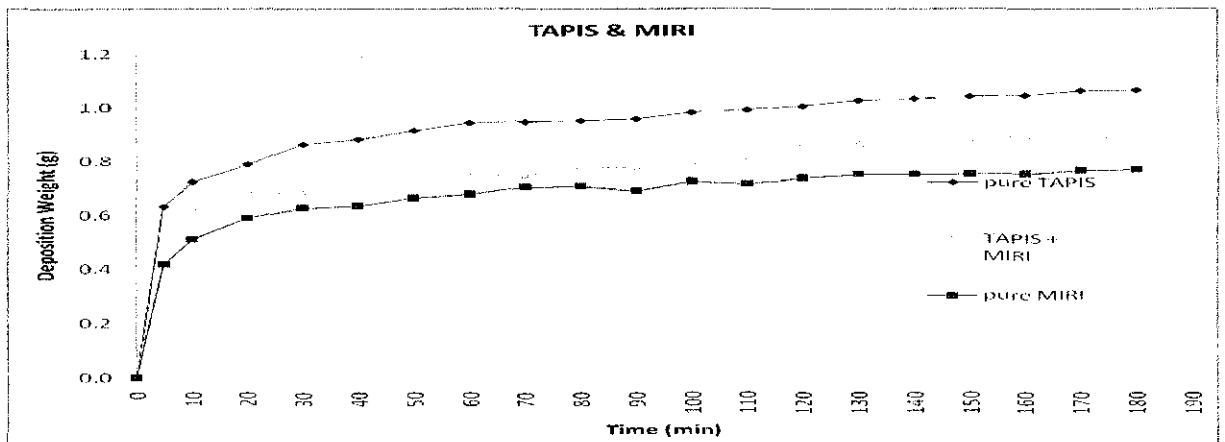

Figure 4.6: Mass of deposit (g) vs time (min) for TAPIS-MIRI blend

Based on the results, it is observed that MASSA is a good blending partner for TAPIS and MIRI, since it has the lowest paraffin wax. When two crude are mixed, the amount of paraffin will be averaged and deversified accordingly. Therefore, the higher-paraffin-crude before mixed will have less deposition after it is blended with the lower-paraffin-crude. This is verified in the three graphs above.

Based on the three figures above, it is observed that the blending causes slight reduction in all systems. Firstly for TAPIS-MASSA system, the deposition has been reduced in an average of 20%. Secondly, for MASSA-MIRI, the deposition is reduced for about 8% but with slightly unstable condition, since the blending effect is unstable in some of the initial time intervals. And finally for TAPIS-MIRI, the deposition is reduced about 20%. Here, it is indicated that TAPIS-MASSA and TAPIS-MIRI has an equal effect of deposition reduction (20%), because MASSA and MIRI have more less equal amount of paraffin and asphaltene.

In short, all three results shows that the blending is a good intial step to reduce the fouling or deposition in heat exchanger wall. The blending effect depends on the properties of the crude oil itself i.e. the amount of asphaltene and paraffin wax. The lower the amount of paraffin wax in the crude, the better it is for the blending partner. Higher paraffin wax crude should be blended with lower one to get the deposition reduction. This deposition should be further reduced when ultrasonic wave is applied.

#### **4.4 Effect of Ultrasonic Wave**

The last part of this experiment study is to apply the ultrasonic wave into previous blending setups in order to further reduce the deposition tendency in all samples. Each of blend option is filled in crude cylinder again but moved into ultrasonic bath to apply the ultrasonic mitigation. The experiment is repeated for all blending options.

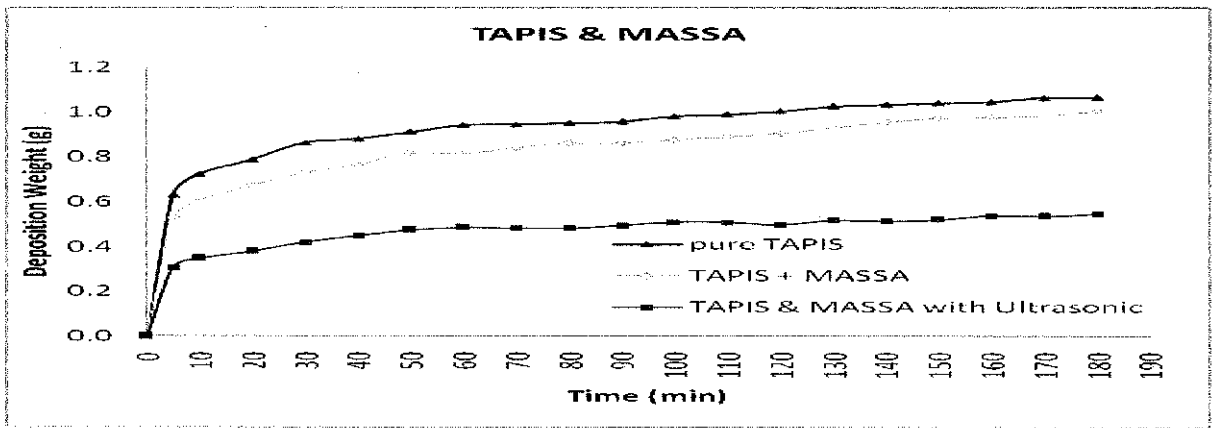

Figure 4.7: Mass of deposit (g) vs time (min) for TAPIS-MASSA blend after ultrasonic

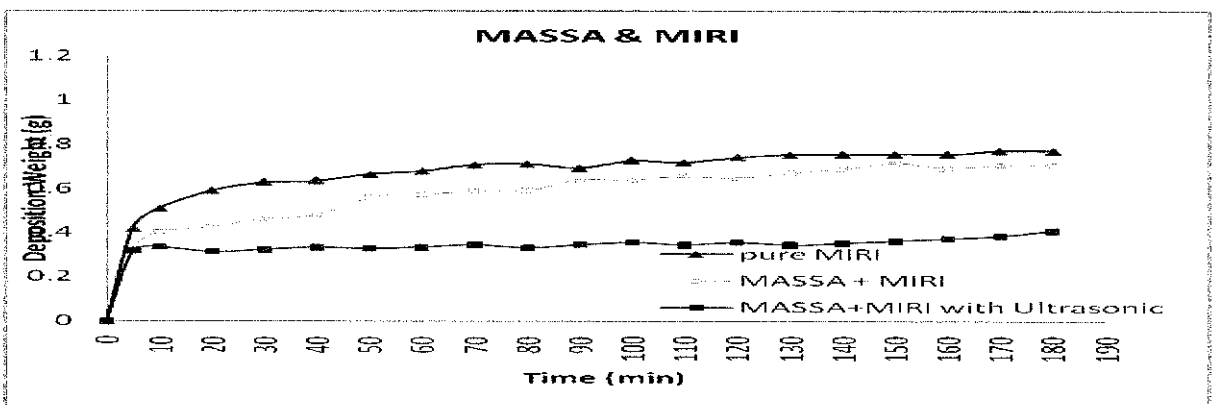

Figure 4.8: Mass of deposit (g) vs time (min) for MASSA-MIRI blend after ultrasonic

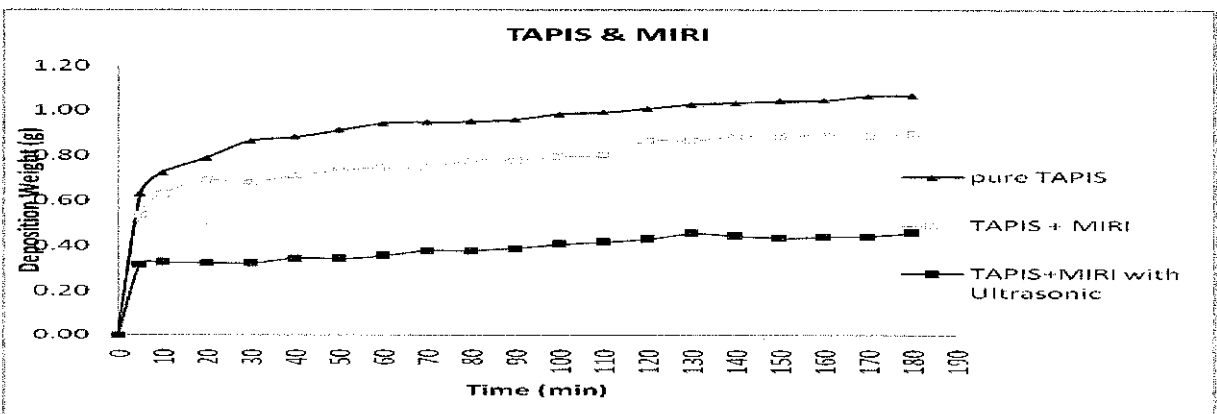

Figure 4.9: Mass of deposit (g) vs time (min) for TAPIS-MIRI blend after ultrasonic

Based on the results obtained above, it is clearly observed that ultrasonic further reduces the deposition for all crude samples. It is an additional mitigation for crude blending system.

## CHAPTER 5

### CONCLUSION

Heat exchanger fouling is a common problem in industry; however it still can be controlled and mitigated by various techniques, including blending and ultrasonic application. This effort could optimize energy and save the cleaning cost. The results show that the deposition of pure crude oil sample depends on the amount of paraffin wax content. Higher amount of wax causes higher amount of deposition. This is proved in the first result, where TAPIS has the highest amount of deposition since it has the highest amount of paraffin wax (30.67%) compared to MASSA (6.93%) and MIRI (11.85%). Besides, for all set of temperature variation, deposition favors at the lowest crude oil temperature (45°C) and wall temperature (-3°C). This occurs because deposition depends on the temperature differences and amount of crude oil temperature below the cloud point. However, the deposition rate for all cases decreases as time goes by, because the deposition itself creates an insulation layer to the heat flow, which reduces the effective differential temperature. Next, blending is proved as a good solution to create an initial step of fouling mitigation. Each blending system causes the significant deposition reduction, specifically TAPIS-MASSA (20%), MASSA-MIRI (8%) and TAPIS-MIRI (20%) This happened because different crude oil sample has different amount of paraffin wax. The wax content has been reduced accordingly after the samples were mixed. Apart from that, this research also involved the in-situ ultrasonic wave application at highest power (600W) and lowest frequency (28 kHz). The combination of blend and ultrasonic application was proved to further effectively reduce the deposition in each system namely TAPIS-MASSA (50%), MASSA-MIRI (50%) and TAPIS-MIRI (60%). In short, crude oil blending and ultrasonic application were proved as an effective method of fouling mitigation.

As a recommendation, this project should be continued properly by conducting the experiment for ultrasonic without blending. This should be done to observe the additional significant effect of blend. Besides, the experiment should also be repeated by using other available crude oil samples, so that the specific result for each sample could be explored.

## REFERENCES

- [1] Van Nostrand, W.L.; S.H. Leach and J.L. Haluska (1991), "*Economic Penalties Associated with the Fouling of Refinery Heat Transfer Equipment*" in "*Fouling of Heat Transfer Equipment*", Hemisphere Publishing, Washington DC.
- [2] Panchal C. B., Bott, Sommerscales and Toyama (1997), "*Fouling Mitigation in the Petroleum Industry: Where do we go from here?*" in "*Fouling Mitigation of Industrial Heat-Exchange Equipment*", Begell House, New York.
- [3] Epstein, N., (1983), "*Thinking about Heat Transfer Fouling: A 5 x 5 Matrix*", Heat Transfer Engineering, 4, pg43-56.
- [4] Samuel Asomaning, (1992), "*Heat Exchanger Fouling by Petroleum Asphaltenes*", Department of Chemical and Bio-Resource Engineering, University of Alberta, Canada.
- [5] C. B. Panchal (1997), "*Review of Fouling Mechanisms*", Argonne National Laboratory, Argonne, Illinois 60439, U.S.A.
- [6] Crittenden, B. D., S. T. Kolaczowski and I. L. Downey (1992), "*Fouling of Crude Oil Preheat Trains*", Chemical Engineering Research, 547-557.
- [7] Lambourn, G. A. and M. Durrieu (1983), "*Fouling in Crude Oil Preheat Trains*", in "*Heat Exchangers Theory and Practice*", Hemisphere Publishing Co., New York.
- [8] Murphy, G. and J. Campbell (1992), "*Fouling in Refinery Heat Exchangers: Causes, Effects, Measurements and Control*" in "*Fouling Mechanisms*", 249-261, GRETh Seminar, Grenoble.
- [9] G. Ali Mansoori, (1996). "*Modelling of Asphaltene and Other Heavy organics*", Chemical Engineering Department, University of Illinois, Chicago.
- [10] Dr. K. J. Bell and Dr. A.C. Mueller (2001), "*Wolverine Engineering Data Book II*", Wolverine Tube Inc., Switzerland, pg45-47.

- [11] Hans Muller-Steinhagen, (2000). *Heat Exchanger Fouling: Mitigation and Cleaning Technologies*, Publico Publication, UK, 6-29.
- [12] T.R Bott, (1994). *Fouling of Heat Exchangers*, Journal of Chemical Engineering, University of Birmingham, UK.
- [13] H.J.A.F. Tulleken, L.J.A. Zoetemeijer and J.F. Hollenberg (1998), "*Fouling Abatement and Condition Monitoring of Heat Exchangers*".
- [14] Garret-Price (1985), B.A et al. "*FOuling of Heat Exchangers- Characteristics, Costs, Prevention, Control and Removal*", Noyes Publication, Park Ridge, New Jersey.
- [15] Process NMR Associates, (1997). "Crude Oil Blending Application", [http://www.process-nmr.com/fox-app/crd\\_bldng.htm](http://www.process-nmr.com/fox-app/crd_bldng.htm), 5<sup>th</sup> August 2010.
- [16] F. John Fuchs (2002), "*Ultrasonic Cleaning, Fundamental Theory and Application*", Blackstone Ultrasonic, New York, 1-14.
- [17] PETRONAS Trading Corporation Sdn Bhd (2010), "*Crude Oil Marketing Trading*", [http://www.petronas.com.my/our\\_business/oil/marketing\\_trading/crude\\_oil.aspx](http://www.petronas.com.my/our_business/oil/marketing_trading/crude_oil.aspx), 21<sup>st</sup> August 2010.