

Study of FAME Formation Using Porous Membrane (Hydrophilic & Hydrophobic)

by

Maria Elena Bt Zarul Ahmad

Dissertation submitted in partial fulfilment of
the requirements for the
Bachelor of Engineering (Hons)
(Chemical Engineering)

JANUARY 2010

Universiti Teknologi PETRONAS

Bandar Seri Iskandar

31750 Tronoh

Perak Darul Ridzuan

LIST OF FIGURES

Figure 1: Stoichiometric reaction for conversion of triglyceride to fatty acid alkyl esters.	5
Figure 2: Batch Reaction Process	7
Figure 3: Plug-flow reaction system	8
Figure 4: Flow of manufacturing SPG	12
Figure 5: Electron microscope photograph of SPG	13
Figure 6: SPG membrane	13
Figure 7: Design of membrane reactor (opened)	14
Figure 8: Design of membrane reactor (combined)	15
Figure 9: Inside design of membrane reactor	15
Figure 10: Completed reactor	16
Figure 11: Inside reactor	16
Figure 12: Schematic diagram of experimental design of process flow	17
Figure 13: Membrane reactor in waterbath	19
Figure 14: Water pump	19
Figure 15: Permeated product	20
Figure 16: Two visible phases of permeate product	22
Figure 17: Top layer of permeate products	24
Figure 18: Bottom layer of permeate products	24
Figure 19: Top layer of raffinate products	25
Figure 20: Bottom layer of raffinate products	26
Figure 21: Flow within membrane reactor	27
Figure 22: Separation of TG and FAME by membrane	31

LIST OF TABLES

Table 1: Specifications for Biodiesel (B100) – ASTM D6751-09	9
Table 2: Definitions of the properties in ASTM D6751	10
Table 3: GC-MS result for permeate layer of 0.1 μ m pore size	21
Table 4: GC-MS result for permeate layer of 19.9 μ m pore size	22
Table 5: Weight of feedstocks and products	27
Table 6: Weight of compounds from products of 0.1 μ m membrane pore size	28
Table 7: Weight of compounds from preproducts of 19.9m membrane pore size	28

CERTIFICATION OF APPROVAL

Study of FAME Formation Using Porous Membrane (Hydrophilic & Hydrophobic)

by

Maria Elena Bt Zarul Ahmad

A project dissertation submitted to the
Chemical Engineering Programme
Universiti Teknologi PETRONAS
in partial fulfilment of the requirement for the
BACHELOR OF ENGINEERING (Hons)
(CHEMICAL ENGINEERING)

Approved by,

(Professor Dr. Yoshimitsu Uemura)

UNIVERSITI TEKNOLOGI PETRONAS

TRONOH, PERAK

JANUARY 2010

CERTIFICATION OF ORIGINALITY

This is to certify that I am responsible for the work submitted in this project, that the original work is my own except as specified in the references and acknowledgements, and that the original work contained herein have not been undertaken or done by unspecified sources or persons.

MARIA ELENA BT ZARUL AHMAD

ABSTRACT

FAME is short for fatty acid methyl ester, also commonly known as biodiesel. As many have been aware, the sources of fossil fuel has decreased alarmingly in the past century hence the use of biodiesel have been researched and promoted to one day, replace fossil fuels. Biodiesel has many advantages, which are reducing public dependence on foreign petroleum, substituting the limited supplies of fossil fuel, reducing greenhouse effect, air pollution and public health risk, and improving the local economy.

The idea behind this project is to use a membrane tube in a reactor to selectively permeate biodiesel from the oil feedstock during transesterification process. The membrane used is a new material developed in Japan, made of Shirasu (which can be found mainly in South Kyushu). It is used as multi-functional glass because of its innumerable pores of uniform micron size that can be changed easily.

Membrane reactor technology offers inherent process reliability compared to batch processes and it has several advantages over conventional reactors. Membrane reactors can integrate reaction and separation into a single process thus reducing separation costs and recycle requirements, offers enhancement of thermodynamically limited reactions resulting in higher conversions per pass, have controlled contact of incompatible reactants and eliminate undesired side reactions.

ACKNOWLEDGEMENT

This thesis would not have been possible without the help of my supervisor, Professor Dr. Yoshimitsu Uemura, and Mr. Wissam, a Postgraduate student, of University Teknologi PETRONAS (UTP). With their guidance, I managed to carry out this research project in timely manner and successfully. Their level of knowledge and experience in Biodiesel production has improved my understanding in this industry thus making the execution of this project bearable.

Also, I would like to show my deepest gratitude to the lab technicians who have helped me with the equipments and sharing their experiences with Biodiesel. Without them, I may not have finished this project in time. Their patience is valued.

Lastly, I am grateful to my friends and family who have shown support and given me encouragements in the midst of executing this project. It has helped me boost my confidence and determination to complete this project successfully.

CHAPTER 1

INTRODUCTION

1.1 Background

Fatty acid methyl esters (FAME) or better known as biodiesel is a renewable energy to petroleum diesel. Though the term is 'biodiesel', it can be blended with petroleum fuel diesel. Malaysia currently is the world's second largest palm oil producer, with Indonesia being the first, according to World Bank and Asian Development Bank.

Biodiesel is commonly made by chemically altering organic oil with the presence of a catalyst and an alcohol. The main components of biodiesel or fatty acid alkyl esters are composed of mono-alkyl esters of long chain fatty acids, the product of the reaction of a straight-chain alcohol with lipids (triglycerides or TG).

Biodiesel can be used in any diesel engine with few to no modifications. The main effect is that it acts like a lubrication that cleans the engine. If the engine has been running on fossil fuel before, the fuel filters of the engine has to be changed to discard the sludge from the petroleum. This effect is more pronounced when using B100 (100% biodiesel) and may be less with B20 (20% biodiesel, 80% petroleum diesel). Tan Sri Datuk Dr Yusof Basiron, CEO of Malaysian Palm Oil Council (MPOC), said during his interview (Interview with Tan Sri Datuk Dr Yusof Basiron, Chief Executive Officer of MPOC 2006) that researches has been done and a blend of refined palm oil with diesel at 5% will be sufficient for an engine.

As of 2010, 92 licenses have approved for biodiesel production, which makes it a total approved capacity of 10.5million tonne per annum in Malaysia. In 2009, 14 biodiesel plants with a total capacity of 197200 tonne per annum are in operation and 5 plants with capacity of 25000 tonne per annum are not in operation but already completed in construction (Y.M., et al. 2009).

1.1.1 Advantages of Biodiesel

1. Reduce public dependence on foreign petroleum

United States are at record level at petroleum imports and it will continue to rise while our local oil supplies shrink. With today's development, the transportation sector has greater demand for gasoline, diesel fuel and petroleum for energy. Since biodiesel can be produced domestically and industrially using agricultural oils, and Malaysia being the largest producers of Palm Oil, biodiesel has the best potential to reduce demand of imported petroleum. (Mongabay.com n.d.)

2. Substitute limited supplies of fossil fuel

Biodiesel can help reduce the use of fossil fuels as it uses vegetable oil, waste fats and oils.

3. Reduce greenhouse effect

The burning of fossil fuel has increased the levels of carbon dioxide (CO₂) and other harmful emissions that trap heat in the atmosphere. Because biodiesel is a renewable energy, it does not emit poisonous and harmful gases, thus reduce the greenhouse effect caused by the transportation sector.

4. Reduce air pollution and public health risks

Biodiesel can play a role in reducing the emissions of many air pollutants, especially the areas targeted by Environmental Protection Agency (EPA). These include particulate matter (PM), carbon monoxide (CO), hydrocarbons (HC), sulfur oxides (SO_x), nitrogen oxides (NO_x) and air toxics.

5. Improve local economy

Since Malaysia produces the largest amount of Palm oil, biodiesel can shift the spending on petroleum from foreign countries to domestically produced energy and offers new energy related markets to farmers.

1.2 Problem Statement

Membrane based separations are well-established in water purification, protein separations and gas separations. Commercial applications of membrane technologies are limited to separations involving aqueous solutions and relatively inert gases. The use of membranes to treat non-aqueous solutions is an emerging area in membrane technologies. Therefore, this project is executed to study the formation of biodiesel using porous membrane reactor as well as overcoming the following challenges faced in current commercial production of biodiesel.

1. Mass transfer limitation: lipids and methanol are immiscible under normal reaction conditions.
2. The reversible nature of the transesterification means that there will always be unreacted glycerides, leaving the unconverted or partially converted material in the biodiesel.
3. High cost of virgin feedstock leads to use of low cost feedstock which is high in water and/or FFA: results in difficult downstream purification of biodiesel and poor cold flow properties.
4. Downstream purification, i.e. water washing to remove excess alcohol and catalyst may generate large amounts of waste water and energy consumption.
5. Most commercial processes are run in batch mode.

1.3 Objectives

- Develop a novel semi-continuous membrane reactor using base-catalyzed transesterification of cooking palm oil that can:
 1. Reduce FFA and water content in biodiesel produced.
 2. Lower the separation load of TG.
 3. Produce a good quality of FAME.
 4. Improve the flux of the membrane tube.
- To study the effect of the membrane pore size on the retention of oil in the reactor.

CHAPTER 2

LITERATURE REVIEW

2.1 Biodiesel Production Process

There are different approaches to produce and purify biodiesel and different chemistry used for the transesterification process in this industry. The choices made will be based on type of feedstock, capacity and operating mode with the selection of the basic process chemistry and layout for a specific location.

2.1.1 Feedstock Selection

Raw materials such as vegetable oil, animal fats and recycled greases are essential in the production of biodiesel since these materials comprise of triglyceride and free fatty acids which contribute to the burning property of biodiesel. To form biodiesel, a fatty acid methyl ester, presence of alcohol is necessary.

The initiation of transesterification process requires the use of catalyst because alcohol is sparingly soluble in the oil phase. The catalyst allows the increment in solubility that allows reaction to proceed at a reasonable rate. Commonly, strong mineral bases like sodium hydroxide and potassium hydroxide are used as catalysts.

2.1.2 Fats and Oils

The appropriate fats or oils to be used are chosen by considering the chemistry and economic factor. In terms of chemistry, the amount of free fatty acids and triglycerides are important as they affect the type of biodiesel process used. Also, the presence of contaminants such as colour and odor bodies are taken into account since they can reduce the value of glycerol produced and affect the extent of feedstock preparation necessary to use a given reaction chemistry hence reducing the market of the fuel to the public.

There are many options for triglyceride. Vegetable oils, sources are soybean, canola, palm, jatropha and rape. Animal fats are products of rendering operations that includes beef tallow, lard, fish oils, and poultry fat. Less expensive triglyceride can be obtained from household waste such as brown grease and soapstock, however the products are not marketable.

In this project, cooking palm oil will be used due to its high free fatty acid and triglyceride content, its availability as it is low in cost and it is easy to obtain.

2.1.3 Alcohol

Methanol, ethanol, isopropanol and butyl are among the common alcohols that are used in the production of biodiesel. Since water can interfere with transesterification reactions which results in poor yield and high level of soap, free fatty acids and triglyceride in biodiesel, alcohol is introduced into the process. The choice of alcohol to be used is not critical as long as the biodiesel produced meets ASTM 6751 specifications. However, the cost, amount, ease of recovery and recycling, fuel tax credits and global warming issues influence the choice of alcohol.

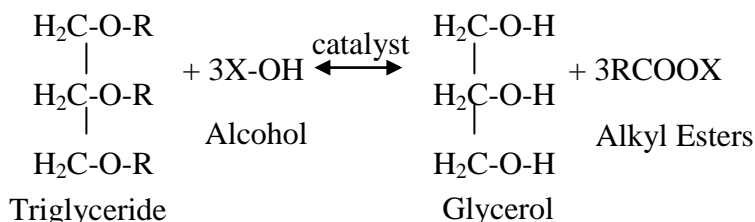

Figure 1: Stoichiometric reaction for conversion of triglyceride to fatty acid alkyl esters.

In Figure 1, X represents the alkyl group of the alcohol and R represents the long chain of carbons, usually on the order of 11-20 carbon atoms long.

From the above reaction where transesterification occur, the operating mole ratio is supposedly 3:1, though in this reaction, a ratio of 6:1 is required because alcohol is an excess reactant that will push the reaction close to 99.7% yield needed to meet the total

glycerol standard for the fuel grade biodiesel. The excess alcohol is recovered and recycled back into the process to minimize operating costs and harm to the environment. Considering the alcohol needs to be recovered and recycled, methanol is most suitable. Ethanol forms an azeotrope when mixed with water, which makes it expensive to be purified during recovery, whereas methanol does not form an azeotrope.

2.1.4 Catalysts

Catalysts can be base, acid or enzyme materials.

When feedstock used is crude or refined vegetable oil, it consists of minimal amounts of free fatty acids that will form soaps and glycerol as byproducts, therefore, base catalyst is commonly used like sodium hydroxide, potassium hydroxide, sodium methoxide and sodium ethoxide. The advantage of using base catalyst is that they form chemical water when dissolved in alcohol reactant and they absorb water from the air during storage.

Acid catalysts, sulfuric acid and phosphoric acid can be used for transesterification process, but due to its slow reaction rate, it is not generally used for industrial processing. Also, using acid catalyst can provide technological and economic advantage for there will not be soap formation and biodiesel will not have to be washed. They can yield up to 90% conversion of biodiesel.

Enzyme catalysts, for example lipase, can react at room temperature without producing spent catalysts. This type of catalyst can be recycled or fixed onto a substrate. When yields starts to decline, the substrate will need new replacement for the immobilized catalyst. With enzyme catalyst, reactions are very specific due to alcohol's ability to inhibit on the enzymes. To prevent this, alcohol has to be fed in three steps with a mole ratio of alcohol to triglyceride 1:1. The reactions are slow for it takes from 4 to 40 hours and more. Usually, transesterification process does not produce biodiesel that meets the standard in ASTM 6751 and soaps are formed.

For this project, experiments will be made using base catalysts as they are obtainable in the lab and to observe the effect on the biodiesel produced from the reactor. Catalyst is a hydrophilic material.

2.2 Biodiesel Production Process Alternatives

2.2.1 Batch Process System

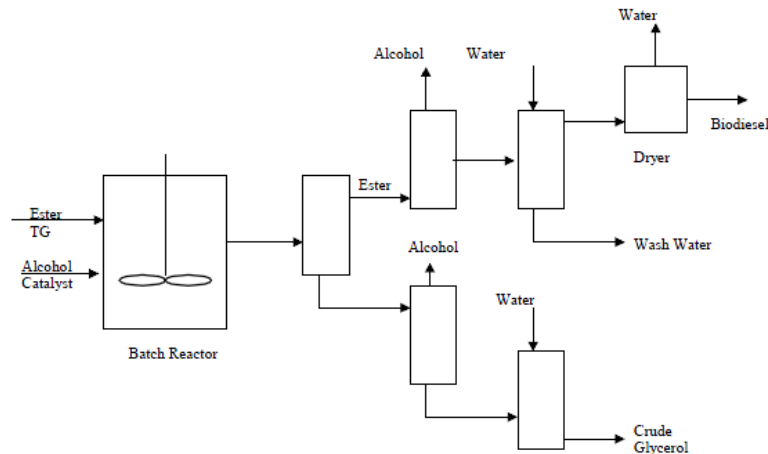

Figure 2: Batch Reaction Process

This method of producing biodiesel is very simple as it can be done at home as well as in industrial scale. Figure 2 shows a typical batch system process flow diagram. The oil is introduced into the system along with alcohol and catalyst. The system is agitated by the stirred tank reactor only during the reaction time. After the reaction time, agitation stops and the reaction mixture is allowed to settle in the reactor to separate the esters and glycerol layers. There are other processes where reaction mixture is pumped into a settling vessel or separated using a centrifuge.

Both glycerol and ester stream may have excessive alcohol hence the streams are sent to an evaporator or a flash unit. After the evaporator, the esters are neutralized and washed gently with warm, slightly acidic water to remove residual methanol and salts and the glycerol is neutralized and washed with soft water. The esters are dried and the final biodiesel is transferred to storage. The glycerol is sent into glycerol refining section.

2.2.2 Continuous Process System

For this process system, continuous stirred tank reactors (CSTRs) are used. To achieve a better extent of reaction, CSTR can be varied in volume in order to have a longer residence time. The developed process can result in high conversions of vegetable oils into biodiesel with excess alcohol. There are also other processes that use intense mixing either from pumps or motionless mixers to initiate the transesterification process or instead of agitating the reaction mixture to increase the residence time, a tubular reactor is used, called plug-flow reactor (PFR). PFRs perform as a series of CSTRs.

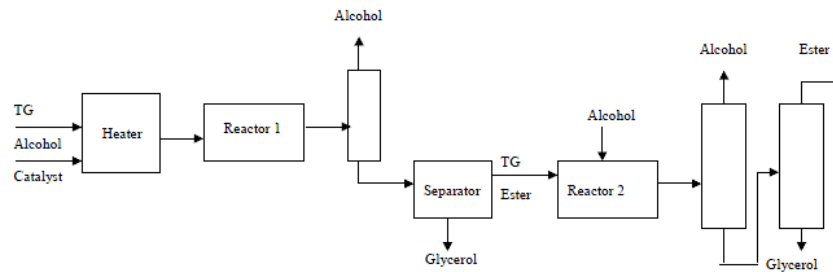

Figure 3: Plug-flow reaction system

2.2.3 Supercritical Process System

This method is very different from batch and continuous methods where supercritical alcohol is used instead of regular alcohol and it is catalyst-free. This process is free of catalyst, has simpler purification because there is no need for removal of alcohol and it can produce a high yield of biodiesel. Although the operational cost is lower than batch and continuous process, this method requires high temperature throughout the system which makes the energy cost higher.

2.2.4 Microwave Absorption Catalysts Process

Microwave absorption solid catalysts were used for transesterification under microwave radiation. In this process, the reaction will experience a longer time, a higher reaction temperature, and a higher alcohol to triglyceride molar ratio as compared to homogeneous-catalysed reaction due to its heat and mass transfer disadvantages. Hence, this method is not convenient for this project.

2.3 Biodiesel Analysis

FAME, widely known as biodiesel, is defined in the standard as a fuel comprised of mono-alkyl esters of long chain fatty acids derived from vegetable oils or animal fats, designated B100.

Biodiesel is the product of the reaction of a straight chain alcohol, methanol, with a fat or oil (TG) to form glycerol (glycerine) and the esters of long chain fatty acids. Biodiesel can be used as B100 (neat) or in a blend with petrodiesel. A blend of 20% biodiesel with 80% petrodiesel, by volume, is termed B20. A blend of 2% biodiesel with 98% petrodiesel is B2, and so on.

Table 1: Specifications for Biodiesel (B100) – ASTM D6751-09

Property	ASTM Method	Limits	Units
Flash point (closed cup)	D 93	403 max	Kelvin
Methanol content	EN 14110	0.2 max	% volume
Water & sediment	D 2709	0.05 max	% volume
Sulfur: S 15 Grade	D 5453	0.0015 max	% mass (ppm)
Sulfur: S 500 Grade	D 5453	0.05 max	% mass (ppm)
Cloud Point	D 2500	Report	degree C
Acid number	D 664	0.5 max	mg KOH/g
Free glycerine	D 6584	0.02 max	% mass
Total Glycerine	D 6584	0.24 max	% mass
Oxidation stability	EN 14112	3 min	hours
Cetane Number	D 613	47 min	

It is important to know the operational properties, as stated in Table 1. These properties vary in accordance to the feedstock used in the fuel's production. ASTM D6751 standard for biodiesel allows 0.24% total glycerol in the final product, which implies that the reaction completion must be about 99.7% to meet the total glycerol standard for the fuel.

Table 2: Definitions of the properties in ASTM D6751

Property	Definition
Flash Point	Measure of residual alcohol in the B100. The flash point is also a determinant for flammability classification of materials. B100's typical flash point is > 200 ° C, classifying it as "non-flammable".
Water & Sediment	<ul style="list-style-type: none"> - Determines the volume of free water and sediment in middle distillate fuels having viscosities at 40 °C in the range 1.0 to 4.1 mm²/s and densities in the range of 700 to 900 kg/m³. - Measure of cleanliness of the fuel. For B100 it is particularly important because water can react with the esters, making free fatty acids, and can support microbial growth in storage tanks.
Total Sulfur	This method covers the determination of total sulfur in liquid hydrocarbons, boiling in the range from approximately 25 to 400 ° C, with viscosities between approximately 0.2 and 20 cSt (mm ² /s) at room temperature.
Cetane number	Measure of the ignition performance of a diesel fuel obtained by comparing it to reference fuels in a standardized engine test.
Cloud Point	<ul style="list-style-type: none"> - Temperature at which a cloud of wax crystals first appears in a liquid when it is cooled down under conditions prescribed in this test method. - Critical factor in cold weather performance for all diesel fuels.
Acid Number	<ul style="list-style-type: none"> - The quantity of base, expressed as milligrams of potassium hydroxide per gram of sample, required to titrate a sample to a specified end point. - Direct measure of free fatty acids in B100. The free fatty acids can lead to corrosion and may be a symptom of water in the fuel.
Free Glycerine	Glycerin present as molecular glycerin in the fuel.
Total Glycerine	The sum of free and bonded glycerin.
Storage Stability	The standard and the test methods for determining storage stability for B 100 are still in the development stage within the ASTM process.

ASTM standards are based on the use of ASTM methods to perform the property measurements. The methods provide detailed directions in respect with the equipment,

the measurements, and the data analysis. Standardization of procedure and reproducibility of results are required in most laboratories.

Each test method outlines a specific procedure to perform a property measurement, and specifies the equipment to be used and the data analysis techniques to be followed. The goal of the methods is to define procedures that will give precise results for the same sample in any laboratory that follows the ASTM procedures in making the measurements. It is common for a method to reference a number of additional Standards and Methods. In order to conform to ASTM requirements, all elements incorporated into a given test must meet all of the standards and methods of respective tests.

2.4 Membrane Reactor Technology

A membrane reactor is a reaction system in which membranes and chemical reactions are combined. This device can carry out a reaction and a membrane-based separation simultaneously in the same physical enclosure or in close proximity. The transesterification of oils and fats is a reversible reaction and could be combined with membrane reactor technology. It has been stated that the porous hydrophobic and hydrophilic composite membranes are promising in the field of membrane distillation because they combine a low resistance to mass transfer achieved by the diminution of the water vapor transport length through the hydrophobic thin-layer of the membrane and a low conductive heat loss through the membrane obtained using thicker hydrophilic sub-layer of the membrane (Khayet, et al. 2006).

A microporous inorganic membrane reactor could selectively permeate FAME, methanol, and glycerol during the transesterification process. The membrane offers a barrier to the passage of oleophilic (have high affinity for oils rather than water) substances present in the lipid feedstock. The vapor-liquid interface ensures the product quality in distillation, as the oleophilic-hydrophilic phase boundary does in the membrane reactor. The membrane serves to retain the smallest oleophilic droplets within the reactor.

The membrane reactor offers inherent process reliability compared to batch processes (Dube, Morse, et al., Effect of membrane pore size on the performance of a membrane reactor for biodiesel production 2007). Additionally, it has several advantages over conventional reactors. Membrane reactors can integrate reaction and separation into a single process thus reducing separation costs and recycle requirements, offers enhancement of thermodynamically limited reactions resulting in higher conversions per pass, have controlled contact of incompatible reactants and eliminate undesired side reactions.

2.4.1 SPG Membrane Tube

The membrane tubes to be used for this project will be supplied from SPG Technology Co.Ltd. SPG (Shirasu Porous Glass) is a new material developed in 1981 by Miyazaki Prefectural Industrial Laboratory that is made of Shirasu, a material that can be found mainly in South Kyushu. It is used as multi-functional glass because of its innumerable pores of uniform micron size that can be changed easily.

The base glass of SPG is made of Shirasu, lime and boric acid that is heated to 1350°C. At this temperature, phase separation occurs in the fiber structure of the glass and hydrochloric acid is introduced to thus elute CaO.B₂O₃. Then a glass porous body made of mainly Al₂O₂.SiO₂ is formed which is SPG.

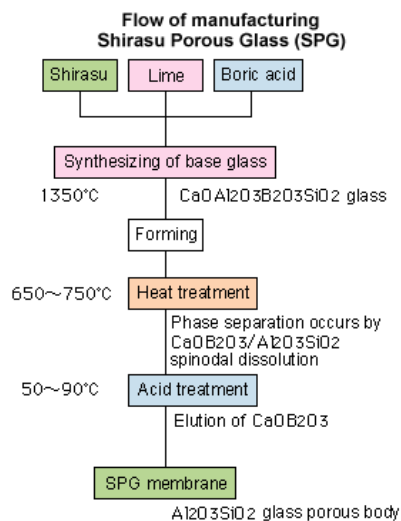

Figure 4: Flow of manufacturing SPG

SPG membrane features include:

1. Provides extremely high mechanical strength and excellent heat resistance and heat insulation in spite of being porous body.
2. Good resistivity to all reagents except to reagents that is strong alkaline and hydrofluoric acid.
3. Good resistivity to mold and bacteria.
4. SPG membrane can be welded.
5. Capable of obtaining hydrophilic or hydrophobic surface and other organic functional groups by modifying chemically of its surface.
6. Provides effective absorption due to high porosity and large specific surface area.
7. Excellent absorption of acetaldehyde and basic gas like ammonia triethylamine.
8. Capable of reforming water cluster.

Description of the membrane tubes ordered:

- Diameter = 0.5cm
- Length = 20cm
- Thickness = $0.04\text{cm} \pm 0.015\text{cm}$
- Pore size = $19.9\mu\text{m}$ and $0.1\mu\text{m}$
- Hydrophilic

Applications:

SPG membrane can be applied in filtration processes, designed in uniform particle size by emulsification, also in other industries.

Figure 5: Electron microscope photograph of SPG

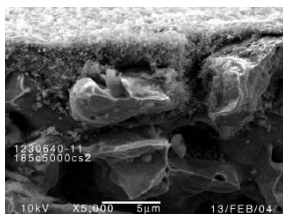

Figure 6: SPG membrane



CHAPTER 3

METHODOLOGY

14th January 2010, the reactor design has been sent to Dixson Fa Engineering Sdn Bhd to be fabricated. On 11th February 2010, the reactor was completed and collected.

3.1 Reactor design

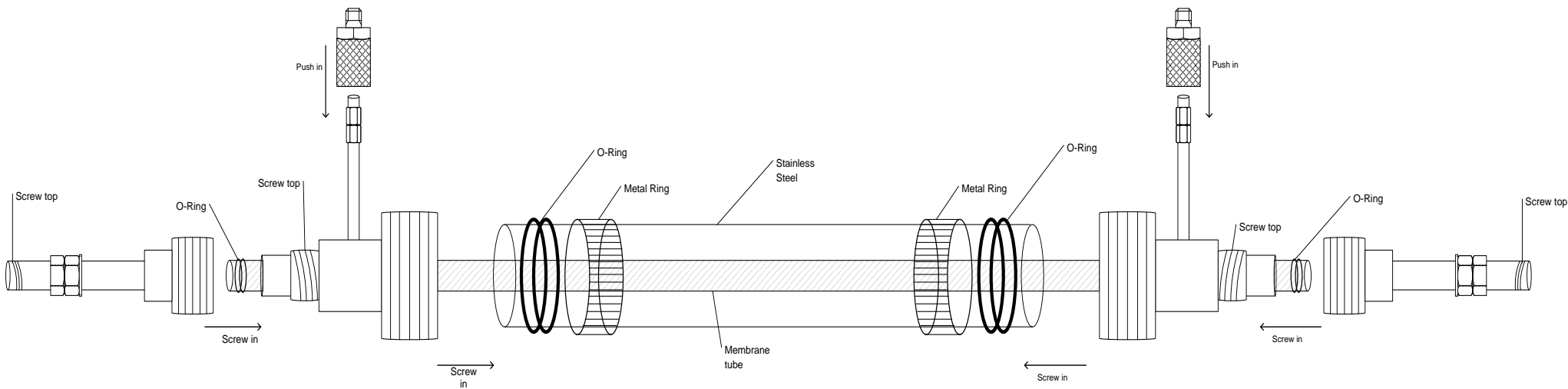

Figure 7: Design of membrane reactor (opened)

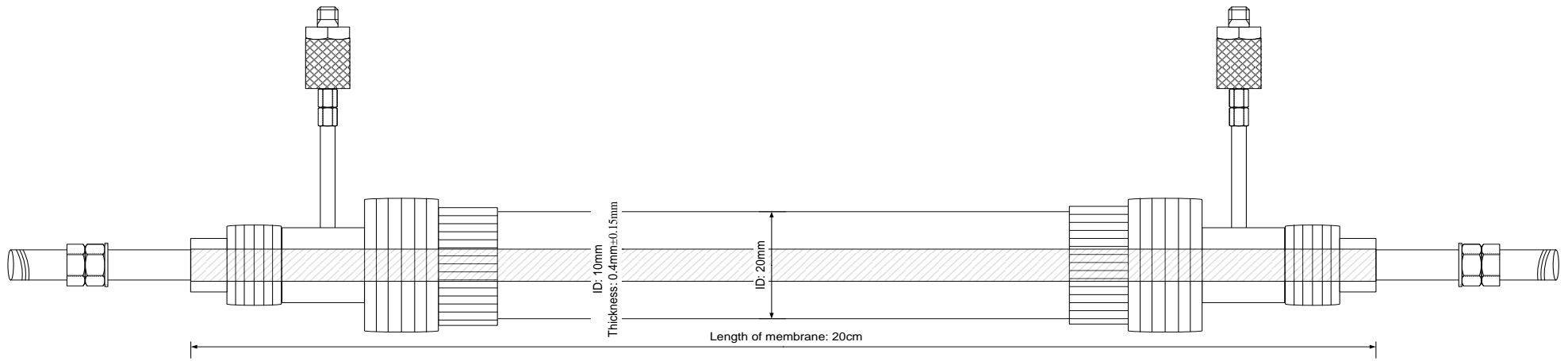

Figure 8: Design of membrane reactor (combined)

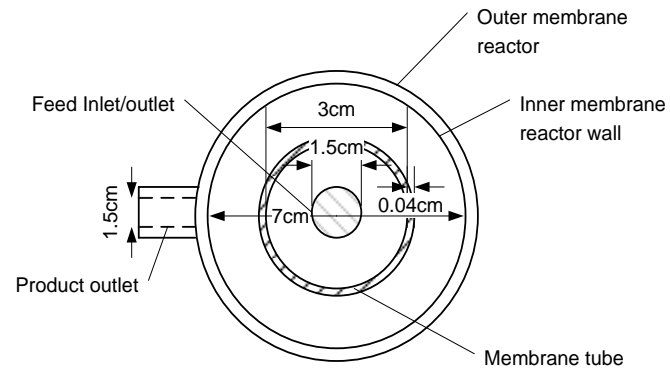

Figure 9: Inside design of membrane reactor

3.2 Reactor

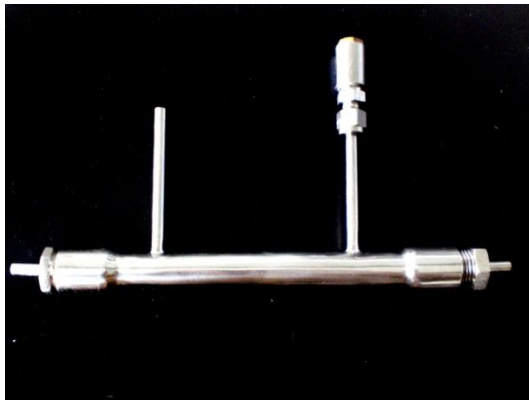

Figure 10: Completed reactor



Figure 11: Inside reactor

Figure 11 and 12 are the images of the fabricated reactor. The body is made of stainless steel and the membrane is placed within the reactor. Stainless steel was chosen because it does not stain, corrode and rust easily as regular steels. It is also a good heat conductor where it transfers heat from the outer surroundings to the inside of its body. Heat conductivity is important as the feedstocks that go through the reactor needs heat to ensure transesterification can occur without having the permeated and raffinated products solidifying inside the reactor thus clogging the pores of the membrane tube. The ends of the reactor can be opened and closed. It is hand sized which makes it easy to handle and it fits in standard water bath.

3.3 Experimental Design

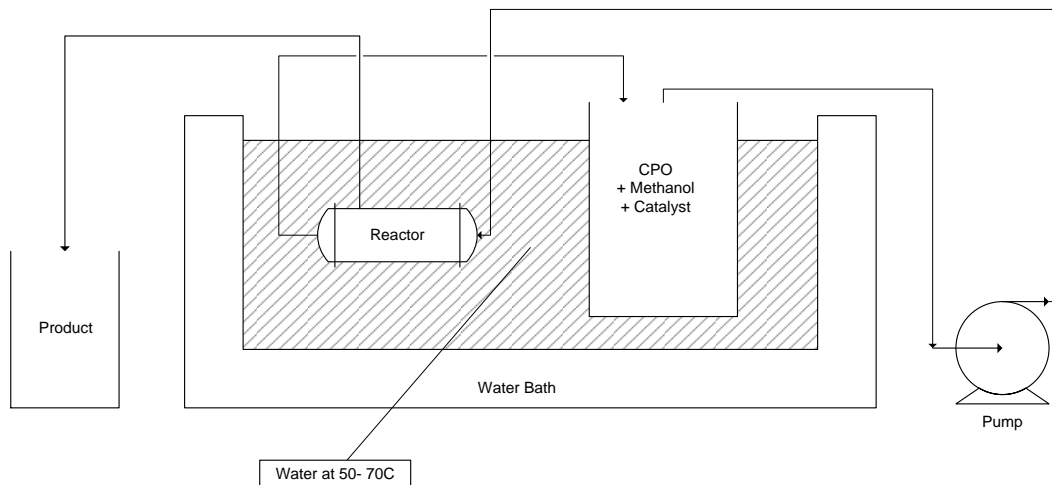

Figure 12: Schematic diagram of experimental design of process flow

A system as shown schematically in Figure 12 was constructed to execute the experimental procedures. SPG membrane tubes will be used with different pore sizes, i.e. $0.1\mu\text{m}$ and $19.9\mu\text{m}$. A water pump will be used to pump the feedstocks (alcohol/catalysts and cooking oil) into the reactor and circulated throughout the system. The connectors used are rubber tubes because it is easy to clean, inexpensive, and can withstand high temperature.

As shown in Figure 12, cooking oil is poured into the beaker and premixed catalyst solution is added into the beaker and the mixture will be placed in the water bath. The water bath can provide heat up to 70°C . The heated mixture will then be pumped into the membrane reactor and the unreacted feed will be recycled back into the beaker. The manipulated variable in this system is the flow rate in mL/min which will be controlled by the pump. Product will be collected from the output of the reactor and will be taken into testing.

3.4 Experimental Procedure

Biodiesel ingredients and proportions:

1L palm cooking oil, 1L methanol (CH_3OH), 200g potassium hydroxide (KOH)

1. Pump oil into reactor
 - Careful to not pump water or other waste that has settled out of the grease, pump appropriate amount of oil into the reactor. This is to clear the rubber tubes from (existing) impurities.
2. Catalyst preparation
 - Calculate the required quantities of reagents based on the volume of feedstock.
 - Add base catalyst to the alcohol (quantities have to be determined by making a test batch).
 - Stir mixture until no granules are visible and catalyst has completely been dissolved.
3. Oil preparation
 - Place oil in a beaker and heat it up to 50-55°C using the hot plate.
4. First reaction
 - When oil is at 50°C, add the catalyst solution. Weigh sample.
 - Switch on the water pump and set the desired flowrate.
 - Place beaker at the inlet tube and allow the feedstock to completely go through the reactor.
 - After about 10minutes of circulation, turn off the pump and collect products and unreacted materials in respective beakers. Weigh the products.
5. Second reaction
 - Allow product collected to settle for more than 2 hours.
 - Observe transition zone between biodiesel and glycerol.
 - Record weight of glycerol drained.
 - Test product samples with GC-MS and GC.
 - Analyse result obtained.

3.5 Experimental Setup

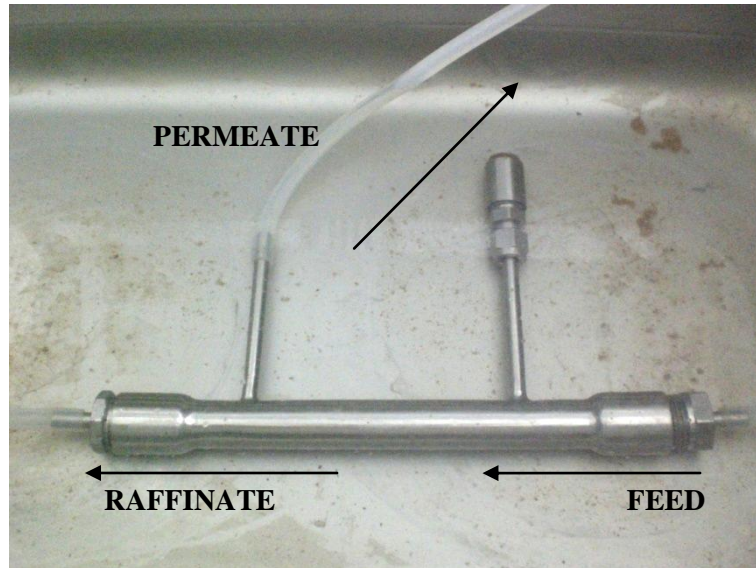

Figure 13: Membrane reactor in waterbath



Figure 14: Water pump

Experimental runs were conducted in the lab. Transesterification reaction produces an intermediate mixture which includes fatty acid methyl esters, glycerol, remaining catalyst and unreacted alcohol (Fleisher n.d.). In the reactor, fatty acid methyl ester and glycerol, and probably methanol will be permeated through the membrane pores and collected at the top of the reactor and the raffinate exits the reactor and circulated back into the inlet. The experiments were made as described in Part **3.4** (pg 18).

CHAPTER 4

RESULT AND DISCUSSIONS

4.1 Effect of Membrane Pore Size

As there are two membrane tubes with the pore size of $0.1\mu\text{m}$ and $19.9\mu\text{m}$, both experimental runs are with the same amount of oil, catalyst and methanol.

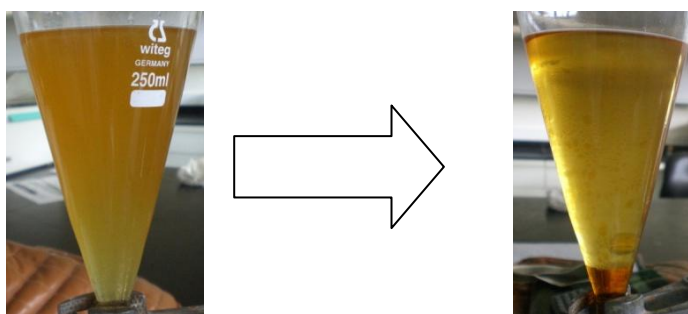

Figure 15: Permeated product

When the experiment was carried out, the permeate from the membrane reactor eluted as a clear, amber homogeneous solution. The permeated product was then placed into a separatory funnel. As in Figure 15, after several hours, the permeate sample separated into two phases with a clear boundary. The two layers are then separated and the top layer was analysed using Gas Chromatography-Mass Spectrometry (GC-MS) to identify the esters that exists in the product samples. The *%Area* is the area of a peak in the graph divided by the total area of peaks, as provided in the results. Table 3 and Table 4 shows the results.

4.1.1 Membrane pore size = 0.1µm.

Table 3: GC-MS result for permeate layer of 0.1µm pore size

Type	Compound name	Common name	%Area	Molecular Weight (g/mole)	Chemical Formula
Methyl Ester	9-octadecenoic acid	Oleic acid	49.42	296.49	C ₁₉ H ₃₆ O ₂
	14-methyl-pentadecanoic acid	Pentadecanoic acid	39.83	326.56	C ₁₇ H ₃₄ O ₂
	9,12-octadecenoic acid	Linoleic acid	6.78	294.47	C ₁₉ H ₃₄ O ₂
	Methyl stearate	Stearic acid	2.76	298.50	C ₁₉ H ₃₈ O ₂
	12-methyl-tetradecanoic acid	Myristic acid	0.31	256.42	C ₁₆ H ₃₂ O ₂
	E-11-hexadecenoic acid	Palmitoleic acid	0.27	282.46	C ₁₈ H ₃₄ O ₂
	Ethyl hexadecanoate	Palmitic acid	0.24	282.48	C ₁₈ H ₃₆ O ₂
	Methyl tetracosanoate	Lignoceric acid	0.13	382.66	C ₂₅ H ₅₀ O ₂
	Methyl 6-hydroxyhexanoate	Caproic acid	0.08	146.18	C ₇ H ₁₄ O ₃
Alcohol	Isooctanols		0.1	130.23	C ₈ H ₁₈ O
	1-octanol		0.09	130.23	C ₈ H ₁₈ O

From Table 3, it is apparent that the highest amount of fatty acid found in the permeate layers are Oleic acids. With membrane pore size of 0.1µm, the %Area of Oleic acid is 49.42%, and the second highest %Area contains Pentadecanoic acid acid. Other than that, other compounds that were found in the samples are Stearic acids, Myristic acids, Palmitoleic acids, Capric acids, Linoleic acids, Caprylic acids and Lignoceric acids. There are also alcohols, for instance Isooctanols, with 0.1% area.

4.1.2 Membrane pore size = 19.9µm.

The permeate product obtained was as in Figure 15 as well, only the quantities are different. The permeated product separates into two visible phases which were extracted from the separatory funnel and the top layer was analysed using GC-MS and the table below shows the result.

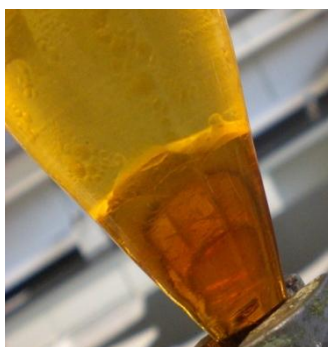

Figure 16: Two visible phases of permeate product

Table 4: GC-MS result for permeate layer of 19.9µm pore size

Type	Compound name	Common name	%Area	Molecular Weight	Chemical Formula
Methyl Ester	9-octadecenoic acid	Oleic acid	49.61	296.49	C ₁₉ H ₃₆ O ₂
	Methyl palmitate	Palmitic acid	42.5	282.48	C ₁₈ H ₃₆ O ₂
	methyl linolelaidate	Linolelaidic acid	4.72	294.27	C ₁₉ H ₃₄ O ₂
	Methyl octadecanoate	Stearic acid	2.09	298.50	C ₁₉ H ₃₈ O ₂
	Ethyl palmitate	Palmitic acid	0.23	282.48	C ₁₈ H ₃₆ O ₂
	methyl n-nonanoate	Capric acid	0.18	172.26	C ₁₀ H ₂₀ O ₂
	Methyl capronate	Caproic acid	0.09	130.18	C ₇ H ₁₄ O ₂
Alcohol	1-nonanol		0.21	144.25	C ₉ H ₂₀ O
	Isooctanols		0.1	130.23	C ₈ H ₁₈ O

Table 4 shows the results obtained from the GC-MS for 19.9 μm pore size. From the table, the highest amount of fatty acid found in the permeate layers are Oleic acids. The %Area of Oleic acid is 49.61%, and the second highest %Area contains Palmitic acid. Additional to that, compounds that were found in the samples are Stearic acids, Myristic acids, Capric acids, Caprylic acids Lignoceric acids and more. There are also alcohols found in the samples, 1-nonanol and isooctanols.

4.2 Fatty acids Comparisons

The products of permeate and raffinate have two layers each and each layer have been tested using Gas Chromatography (GC) column to recognize the presence of glycerol (glycerine) and fatty acids content in the product samples. The concentrations, in μg , of the compounds were given in the results of the GC column. To obtain the percentage of weight (*wt%*), the following equation was used:

$$wt\% = \frac{\text{Concentration of Compounds } (\mu\text{g})}{\Sigma \text{ Concentrations } (\mu\text{g})} \times 100 \quad \text{Equation 1}$$

Based on the graphs obtained from GC analysis results, comparisons in column charts were made between the products from 0.1 μm and 19.9 μm membrane pore tubes in terms of percentage of weight (*wt%*) and fatty acids. By comparing the amount of fatty acids that are present in the product samples, the best membrane pore tube can be chosen. The permeate products need to have minimal amount of fatty acids to prove that it successfully separated the biodiesel from the unreacted oil, methanol and catalyst.

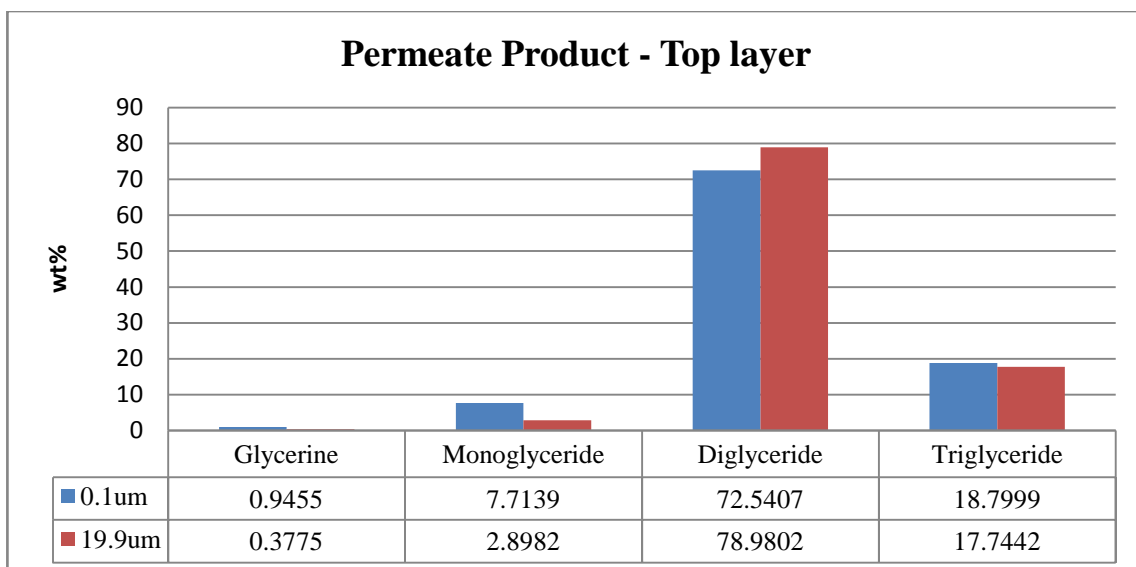

Figure 17: Top layer of permeate products

Figure 17 shows the top layer of the permeate products. From the figure, the samples have traces of glycerine, monoglyceride (MG), diglyceride (DG) and triglyceride (TG). Pore size of 19.9µm has less amount of glycerine, MG and TG but a higher DG than the amounts of glycerine, MG, DG and TG from 0.1µm pore size membrane tube.

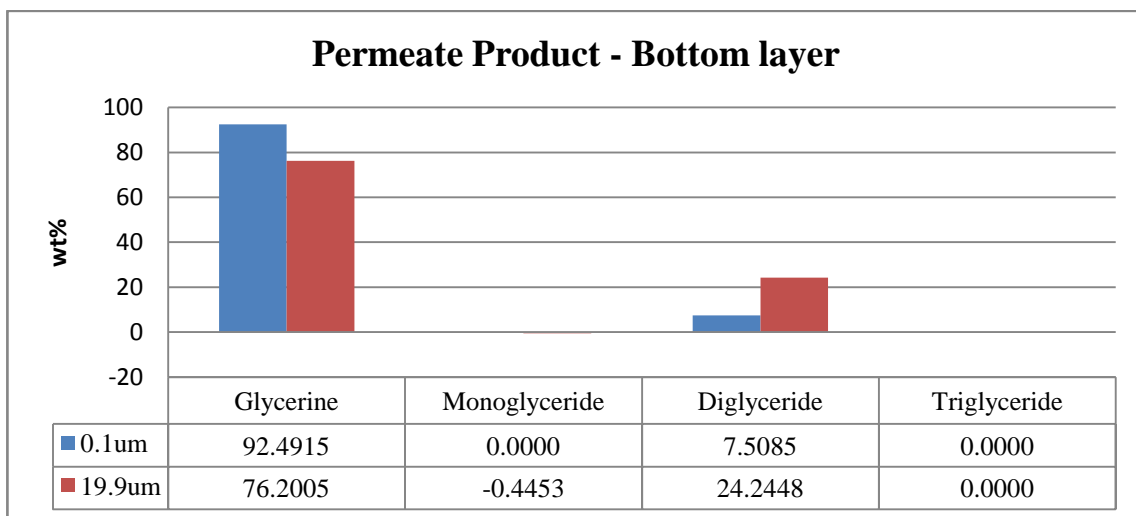

Figure 18: Bottom layer of permeate products

Figure 18 compares the amount of fatty acids in the sample collected from membranes of 0.1µm and 19.9µm pore sizes in the bottom layer of the permeate product. The

products from 0.1 μ m membrane tube, has higher amount of glycerine and lower amount of DG compared to 19.9 μ m membrane tube. MG and TG were not present in products from 19.9 μ m membrane tube. There is a negative amount of MG in this layer of 0.1 μ m membrane tube and no TG traces.

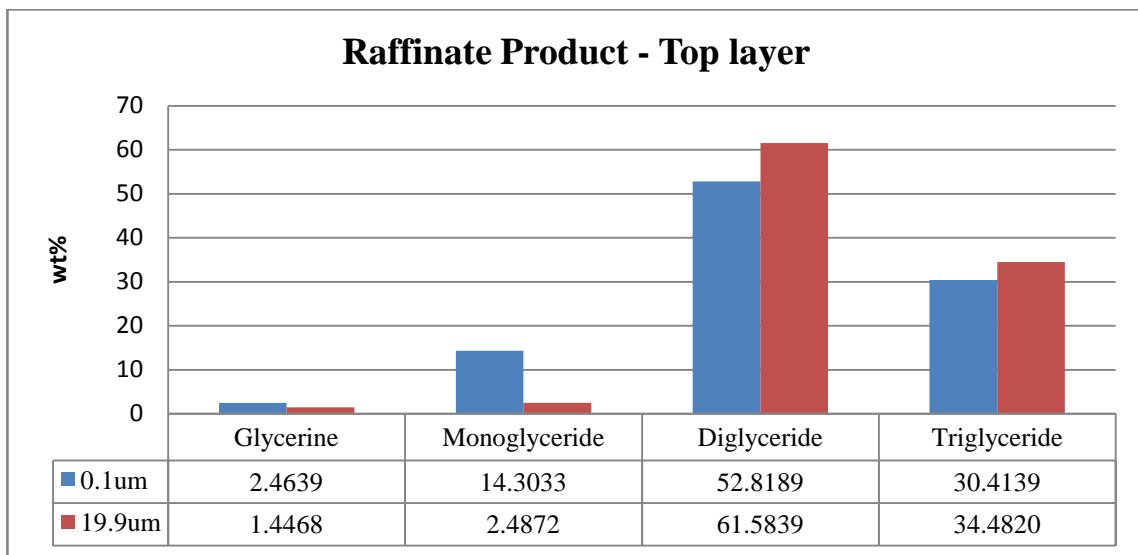

Figure 19: Top layer of raffinate products

Figure 19 exhibits the amount of fatty acids traces in the top layer of the raffinate product. The amount of glycerine and MG from 0.1 μ m membrane tube are more than from 19.9 μ m membrane tube, and the amounts of DG and TG from from 0.1 μ m membrane tube are less than from 19.9 μ m membrane tube.

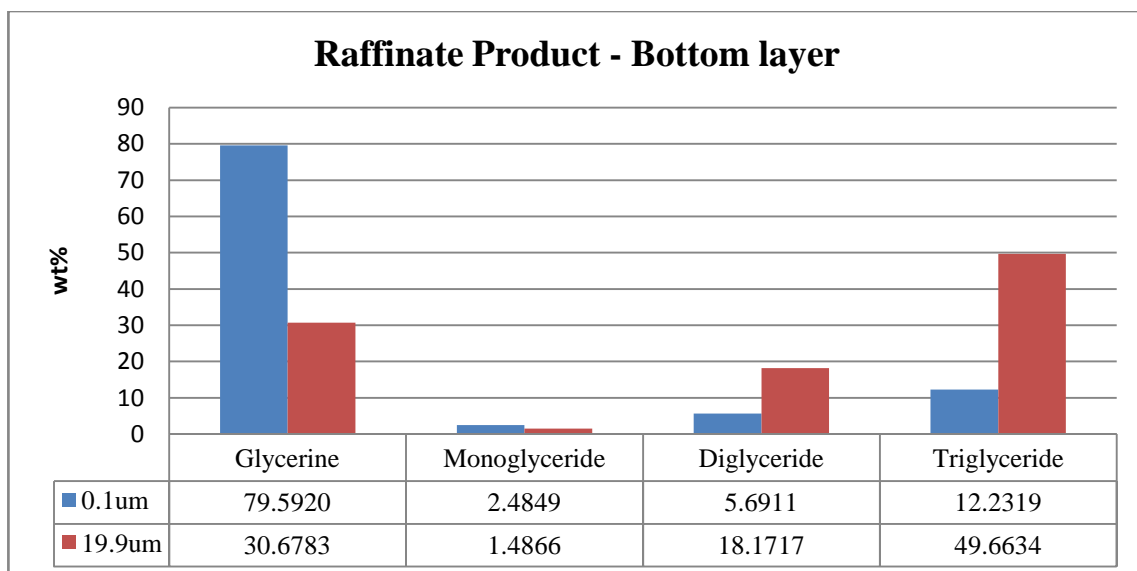

Figure 20: Bottom layer of raffinate products

Compounds of the bottom layer of raffinate products are shown in Figure 20. From the figure, it can be seen that glycerine from 0.1µm membrane tube has the highest amount of glycerine and small amounts MG, DG and TG traces in the product. 19.9µm membrane tube contains high amount of TG and DG but small amount of glycerine and MG.

4.3 Mass Balance

It is known that there are two products collected from the membrane reactor and these products have two layers. The membrane reactor is placed in waterbath with temperature of 55°C and the pump is set to 30mL/min during the experiment (as in Figure 12). Figure 21 demonstrates the flow within the membrane reactor. W1 is the weight of the feedstocks; oil, methanol and catalyst, L1 and L2 are the permeate products where L1 is the top layer and L2 is the bottom layer. L3 and L4 are the raffinate products where L3 is the top layer and L4 is the bottom layer. Using this diagram as a reference, mass balance was calculated to acquire the weight of each compound in the products in terms of percentage.

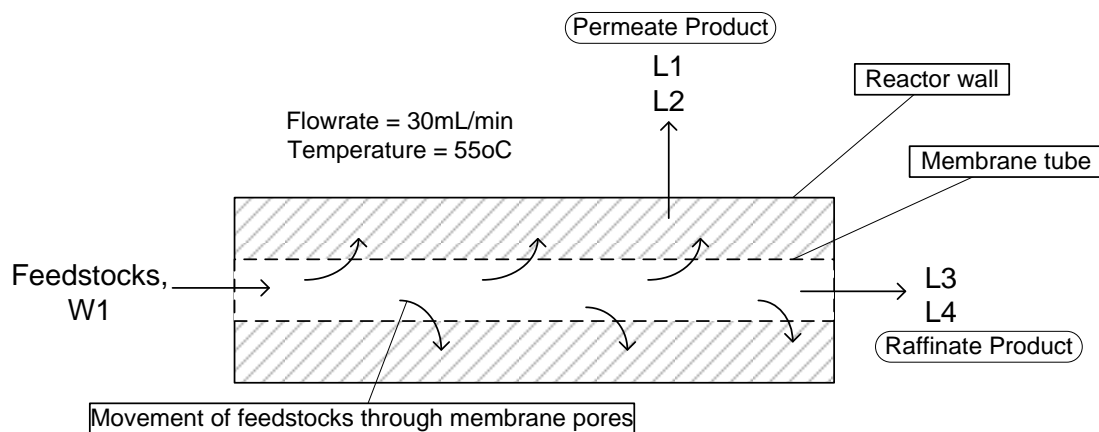

Figure 21: Flow within membrane reactor

To calculate the mass of the compounds in the products, the following equation was used:

$$\text{Weight of Compounds (Wt\%)} = \frac{\text{Weight of Compounds } (\mu\text{g})}{\text{Weight of Sample } (\mu\text{g})} \times 100\% \quad \text{Equation 2}$$

The weights of samples were taken during experimentation, as shown in Table 5 and by using Equation 2, Table 6 and Table 7 were tabulated.

Table 5: Weight of feedstocks and products

Membrane Pore Size	Initial Weight of Feedstocks (g)	Layer	Permeate (g)	Raffinate (g)	Final Weight of Products (g)
0.1 μm	247	Top	140.11	71.10	245
		Bottom	11.30	22.49	
19.9 μm	245	Top	184.45	13.37	231.26
		Bottom	29.27	4.17	

The weight of the feedstocks (oil, methanol and potassium hydroxide) from 0.1 μm membrane pore tube was initially 247g. However the total products, permeate and raffinate, obtained after the experiment was found to be 245g. There has been a loss of 2g of product during the experiment. On the other hand, the initial weight of the

feedstocks from 19.9 μ m membrane pore tube was 245g, and the final weight of the products combined was 231.26g. There has been a lost of products during the experiment for as much as 13.74g.

Table 6: Weight of compounds (%) from permeate product of 0.1 μ m membrane pore size

0.1 μ m	Permeate Products	
Compound Name	Top Layer (L1), Wt%	Bottom Layer (L2), Wt%
Glycerine	0.0741	0.9583
Monoglyceride	0.6042	0
Diglyceride	5.6822	0.07779
Triglyceride	1.4726	0
FAME	92.1669	98.9639

From Table 6, the top layer of the permeate product contained 0.07% glycerine, 0.60% MG, 5.68% DG, 1.47% TG and 92.27% FAME and 0.95% glycerine, 0.08% DG and 98.96% FAME in the bottom layer of the product.

Table 7: Weight of compounds (%) from permeate product of 19.9m membrane pore size

19.9 μ m	Permeate Products	
Compound Name	Top Layer (L3), Wt%	Bottom Layer (L4), Wt%
Glycerine	0.0219	0.2290
Monoglyceride	0.1679	-0.0013
Diglyceride	4.5746	0.0729
Triglyceride	1.0277	0
FAME	94.2079	99.6995

From Table 7, the permeate product consisted of 0.02% glycerine, 0.16% MG, 4.57% DG, 1.02% TG and 94.2% FAME in the top layer, whereas the bottom layer consisted of 0.23% glycerine, 0.07% DG and 99.7% FAME.

4.4 Discussion

Considering the positive pressure difference across the membrane, the FAME/glycerol/methanol/potassium hydroxide phase supposedly passes through the membrane into the permeate stream. The oil and alcohol are immiscible at the reaction temperature (55°C) and the oil molecules aggregate to form droplets dispersed in the alcohol as an emulsion. The oil droplets cannot pass through the membrane because of their large size relative to the membrane pore size.

Table 5 exhibits the weight of the feedstocks and the products from permeate and raffinate stream and as seen in the table, the total weight of the permeate product from 19.9µm is heavier than from 0.1µm membrane pore size. Also, the total weight of the raffinate product from 0.1µm is heavier than 19.9µm membrane pore size. The weights of the top layers signify the weight of methyl esters, and the bottom layers signify the weight of glycerol that permeates through the pores of the membrane. Based on this experiment, both products of transesterification reaction, namely fatty acid methyl ester (FAME) or biodiesel, glycerol and potassium hydroxide are soluble in methanol.

4.4.1 Products from 0.1µm membrane pore tube

The results showed in Table 3 shows that there are high content of esters in the product samples after using GC-MS. There were high amount of Oleic Acid, Pentadecanoic Acid, Linoleic Acid and more. These acids proved that the membrane tube with pore size of 0.1µm can permeate feedstocks that contain esters. The samples were also tested using GC column to analyse the content of fatty acids and glycerol. Based on Figure 17 to Figure 20 and Table 6, the amount of fatty acid contents in the sample products collected was shown. In the top layer of the permeate product, the total content of

glycerol and glycerides were 7.8wt% and 92.2wt% FAME. The bottom layer contains 1.03wt% of glycerol and unsaturated fatty acids, and 98.96wt% of FAME. Theoretically, it was expected that glycerol and fatty acid methyl esters to be permeated, however based on this experiment and the results, there are unreacted oil that were permeated as well. It could be because of the reversible nature of the transesterification process. Although there were MG, DG and TG in the permeated product, there were high amount of fatty acid methyl esters.

4.4.2 Products from 19.9 μ m membrane pore tube

The results from Table 4 showed the content of fatty acid methyl esters in the product. There were high content of Oleic Acid, Palmitic Acid and more, thus proving that transesterification process was successful in producing fatty acid methyl esters. However, based on Figure 17 to Figure 20 and Table 7, there were glycerides and glycerol permeated through the membrane as part of the product. Table 7 showed that the permeate product consisted of 5.8wt% of glycerol and glycerides and 94.2wt% FAME in the top layer, and 0.3wt% of glycerol and glycerides and 99.7wt% FAME in the bottom layer.

As seen from both products of 0.1 μ m and 19.9 μ m membrane pores, the bottom layers consisted higher FAMEwt% compared to the top layer. This is because esters are soluble in MG and DG and insoluble in glycerine. Since MG and DG are hydrophilic, it is unavoidable that they were able to permeate through the membrane pore tubes. It can be summed that the glycerol and glycerides permeated through the membrane were smaller than 0.1 μ m. TG, on the other hand, is hydrophobic. Based on the results obtained (refer to Table 6 and Table 7), there are TG in the permeated products. Unfortunately, the membrane pore tubes were not able to prevent the flow of TG through the membrane pores thus proving that TG droplet size is smaller than 0.1 μ m. It may be also due to errors made during the experiment, for example, the screw top of the membrane reactor was not tight enough to seal the membrane tubes properly therefore allowing the flow of unwanted products through the product tube.

CHAPTER 5

CONCLUSION

Membrane reactor can be used to alleviate many of the difficulties in the current commercial production of biodiesel and successfully carry out the transesterification of oil to FAME. Based on the experiments, cooking palm oil was successfully transesterified using methanol and potassium hydroxide in a membrane reactor. Since oil (TG) is a hydrophobic material and methanol and catalyst are hydrophilic materials, it is necessary to form a two phase system in the operation of a membrane reactor. Therefore, the transesterification of oil to fatty acid alkyl ester is suited to operation in a membrane reactor.

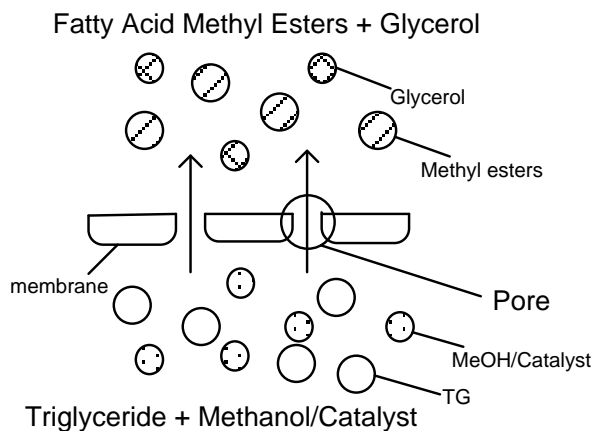

Figure 22: Separation of TG and FAME by membrane

Figure 22 illustrates the movement of the feedstocks which contains oil (TG), and alcohol and catalyst mixture in the membrane tube. The fatty acid methyl esters were expected to permeate through the membrane pores, with glycerol and the unreacted oil and excessive alcohol and catalyst will be the raffinate product. A gas chromatography-mass spectrometry (GC-MS) was used for the determination of compounds of the product collected. There are fatty acids in the products collected from the experiments; as shown on the GC-MS results in Table 3 and Table 4 and thus proving that the membrane reactor is successful in separating oil from the alkyl esters. It was found that

in the product samples, there are saturated fatty acids such as Oleic acid, Stearic acids, Myristic acids, Palmitic acids, Palmitoleic acids, Capric acids, Linoleic acids, Caprylic acids and Lignoceric acids. These acids are coherent with the content of fatty acids in biodiesel hence proves that the biodiesel were successfully permeated through the membrane pores. The presence of alcohols, though minimal, proves that methanol diffuses in the methyl esters as they went through the membrane pores.

While the transesterification process is proven successful, there are small amounts of TG in the permeated products. This shows that the TG droplets are smaller than $19.9\mu\text{m}$ and $0.1\mu\text{m}$. There may be also mistakes made during the experiment which causes the permeation of TG through the membranes. For future experiments, the reactor top must be screwed in as tight as possible and ensure there will not be water that can go into the reactor, whether through the tubes or the reactor tops.

In conclusion, this project has proven that membrane reactor technology should be researched more in depth so as to ensure the quality of the FAME is of satisfactory and the unsaturated fatty acids can be prevented from flowing through the membrane pore tubes.

REFERENCES

- [1] *Biodiesel Production*. http://en.wikipedia.org/wiki/Biodiesel_production.
- [2] DeRoussel, P., D.V. Khakhar, and J.M Ottino. "Mising of viscous immiscible liquids. Part 2: Overemulsification - Interpretation and Use." *Chem. Eng. Sci*, 2001.
- [3] Dube, M. A., Katie Morse, A. Y. Tremblay, and Peigang Cao. "Biodiesel production using a membrane reactor." *Ind. Eng. Chem. Res*, 2007: 52 - 58.
- [4] Dube, M. A., Katie Morse, A. Y. Tremblay, and Peigang Cao. "Effect of membrane pore size on the performance of a membrane reactor for biodiesel production." *Bioresource Technology* 98, 2007: 639 - 647.
- [5] Fleisher, C.A. *Method for recovering unreacted alcohol from biodiesel product streams by flash purification*.
- [6] *Interview with Tan Sri Datuk Dr Yusof Basiron, Chief Executive Officer of MPOC*. October 2006. <http://www.malaysiapalmoil.org/pdf/Interview%20on%20Biodiesel.pdf> (accessed February 19, 2010).
- [7] J. Van Gerpen, B. Shanks, R. Pruszko, D. Clements, G. Knothe. *Biodiesel Production Technology*. NREL, July 2004.
- [8] Kansedo, Jibrail, Keat Teong Lee, and Subhash Bhatia. "Science Direct." *Cerbera odollam (sea mango) oil as a promising non-edible feedstock for biodiesel production*, 2008: 1148-1150.
- [9] Khayet, M., T. Matsuura, M. R. Qtaishat, and J. I. Mengual. "Porous hydrophobic/hydrophilic composite membranes preparation and application in DCMC desalination at higher temperatures." *Desalination* 199, 2006: 180 - 181.
- [10] Ma, F, L. D. Clements, and M. A. Hanna. "Biodiesel Production: A Review." *Bioresource Technology*, 1999: 70 - 71.
- [11] *Mongabay.com*. <http://news.mongabay.com/2005/0926-malaysia.html> (accessed February 19, 2010).
- [12] Mudge, S. M., and G. Pereira. "Stimulating the biodegradation of crude oil with biodiesel preliminary results." *Spill Science Technology* , 1999: 353 - 355.
- [13] Y.M., Choo, Nasrin Abu Bakar, Harrison Lau, Yahaya Hawari, and M.Basri Wahid. *National Biofuel Policy, Deployments and Plans*. 2009. http://www.iea.org/work/2009/bangkok/1_3_Abu_Bakar.pdf.

[14] D. Gunstone, Frank, L. Hardwood, John and B. Padley, Fred. "The Lipid Handbook Second Edition". Chapman & Hall. 1994.

[15] D. M. James and Wang, Chun-Xiao. "Analysis of Glycerin and Glycerides in Biodiesel (B100) Using ASTM D6584 and EN14105". *Agilent Technologies*.

[16] An American National Standard. "Test Method for Determination of Free and Total Glycerin in B-100 Biodiesel Methyl Esters By Gas Chromatography". D 6584 - 00. *ASTM International*.

[17] Zhou, Weiyang and Boocock, D.G.B. "Phase Distributions of Alcohol, Glycerol, and Catalyst in the Transesterification of Soybean Oil". *JAACS* 83, 2006: 1047 - 1052.

APPENDICES

To calculate the appropriate amount of feedstock:

With 200g of cooking palm oil, molecular weight is 857.7g/mol. (Kansedo, Teong Lee and Bhatia 2008)

Catalyst, NaOH, is 0.5% of weight of oil.

$$\frac{0.5}{100} \times 200 = 1\text{g}$$

Weight of methanol to be used depends on the ratio, molecular weight is 32.04 g/mol

Ratio of methanol to oil = 6:1

$$\begin{aligned}\text{oil} &= \frac{200}{857.7} \\ &= 0.2332 \text{ mole}\end{aligned}$$

$$\begin{aligned}\text{methanol} &= 6 \times 0.2332 \\ &= 1.3992 \text{ mole}\end{aligned}$$

$$\begin{aligned}\text{methanol to be used} &= 1.3992 \times 32.04 \\ &= 44.83 \\ &\approx 45\text{g}\end{aligned}$$

Therefore, for 200mL of oil, 1g of NaOH and 45g of methanol are used for the process.

GC-MS Results:

0.1 μm – Permeate (top layer)

Data : MARIA.D02 10/04/16 10:40:51 - 0.1 μm (permeate top)
Sample : maria2
ID : 20100416
Method File Name : ARI.MET

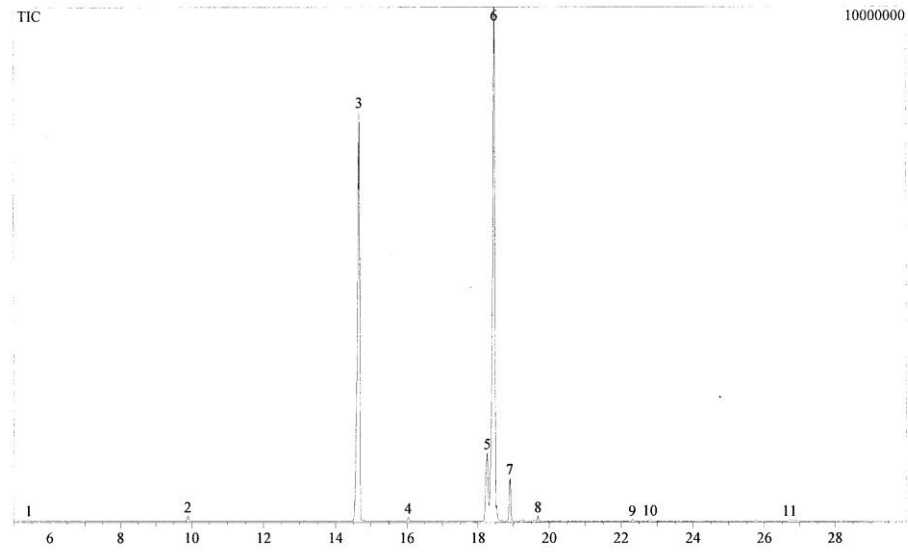

0.1 μm – Raffinate (top layer)

Data : MARIA.D03 10/04/16 11:50:10 - 0.1 μm (raffinate top)
Sample : maria3
ID : 20100416
Method File Name : ARI.MET

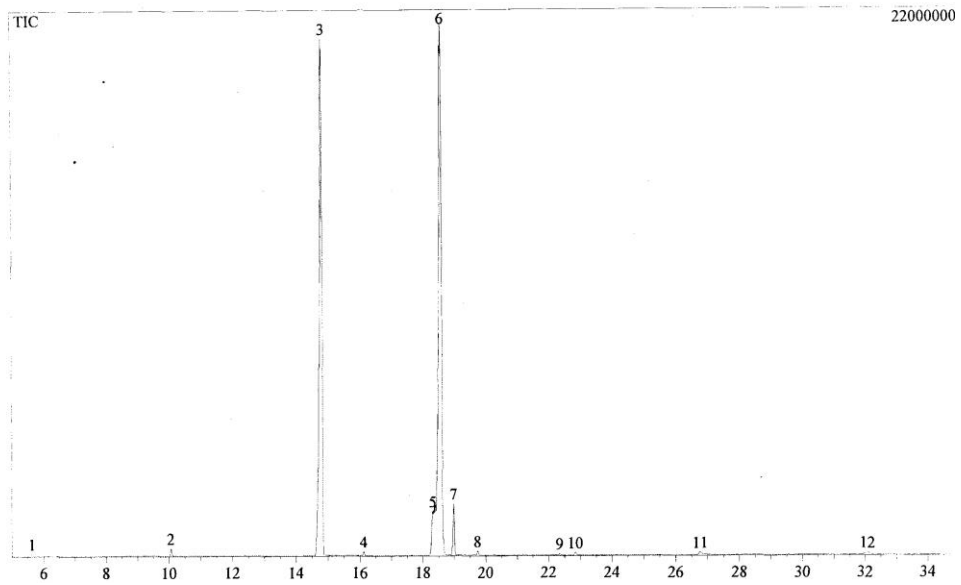

19.9 μ m – Permeate (top layer)

Data : MARIA.D01 10/04/16 09:39:52 - 19.9 μ m (Permeate top layer)
Sample : maria1
ID : 20100416
Method File Name : ARI.MET

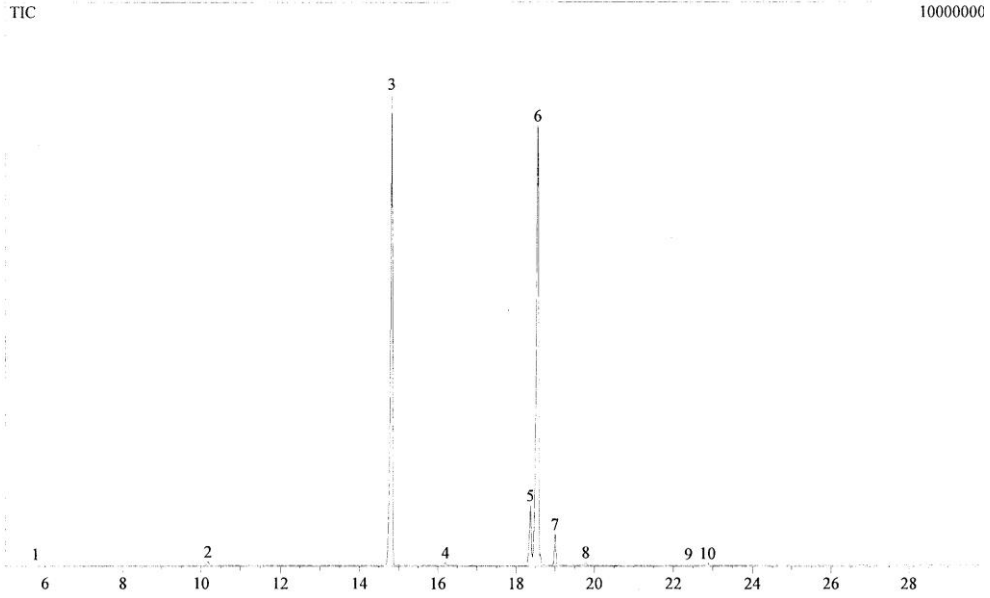

19.9 μ m – Raffinate (top layer)

Data : MARIA.D04 10/04/16 12:58:26 - 19.9 μ m (Raffinate top layer)
Sample : maria4
ID : 20100416
Method File Name : ARI.MET

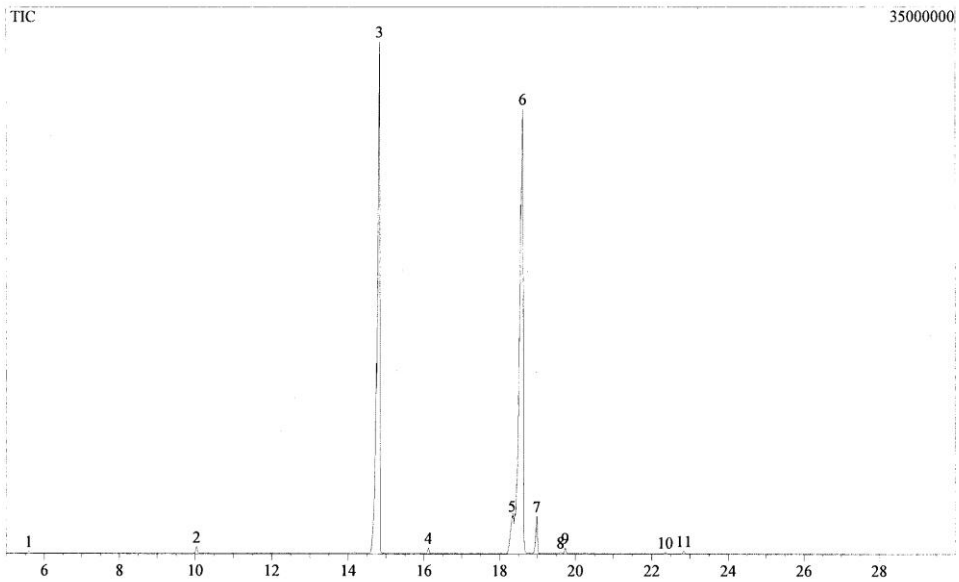

GC Results:

Permeate product, top layer.

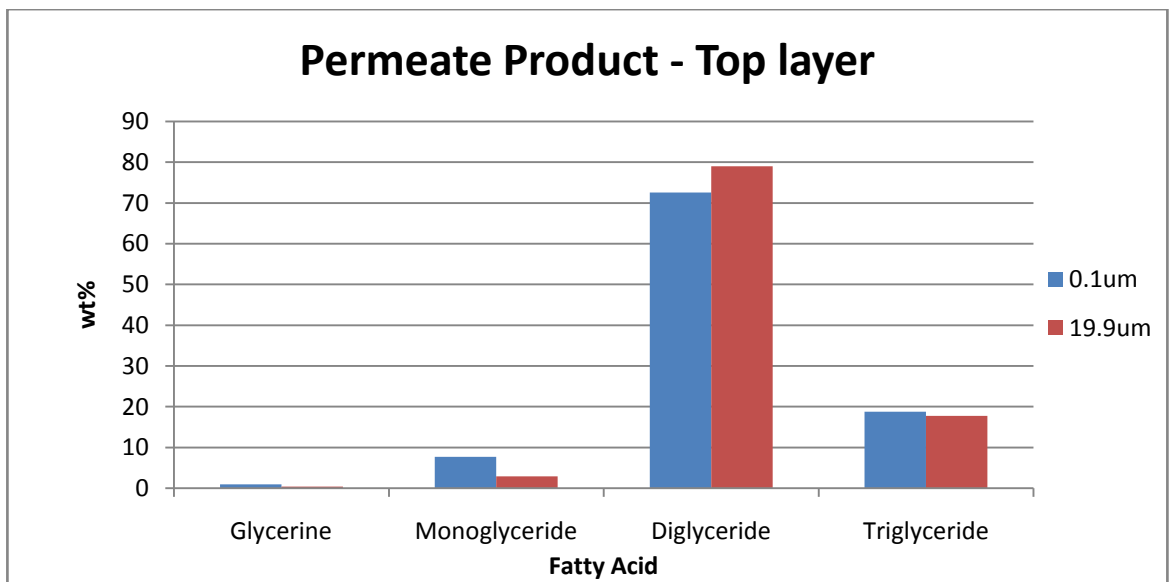
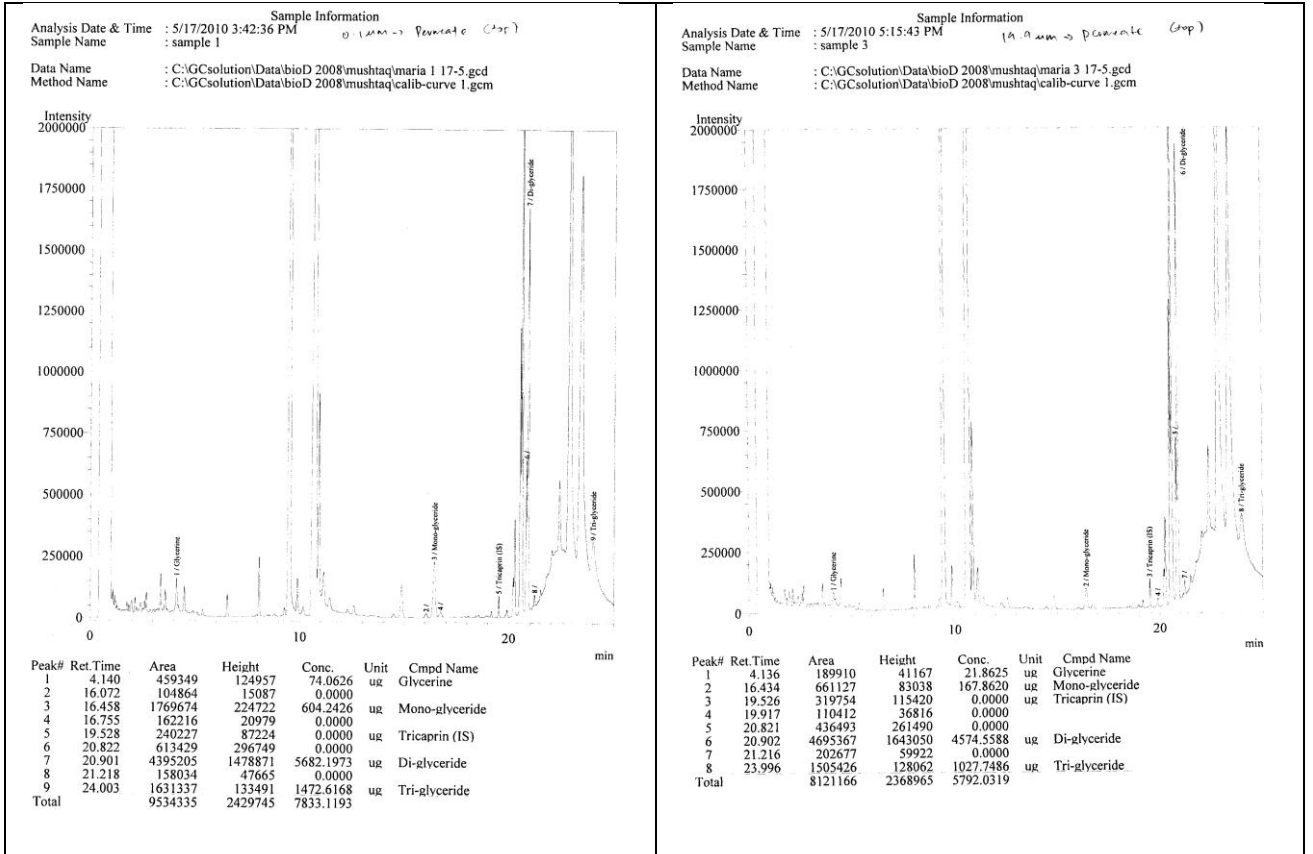

0.1 μ m - Permeate Product, Top layer

Compound Name	Concentration (mg)	wt%
Glycerine	74.0626	0.945506
Monoglyceride	604.2426	7.713946
Diglyceride	5682.1973	72.54067
Triglyceride	1472.6168	18.79988
Total	7833.1193	100

19.9 μ m - Permeate Product, Top layer

Compound Name	Concentration (mg)	wt%
Glycerine	21.8625	0.377458
Monoglyceride	167.862	2.898154
Diglyceride	4574.5588	78.98021
Triglyceride	1027.7486	17.74418
Total	5792.0319	100

Raffinate product, top layer.

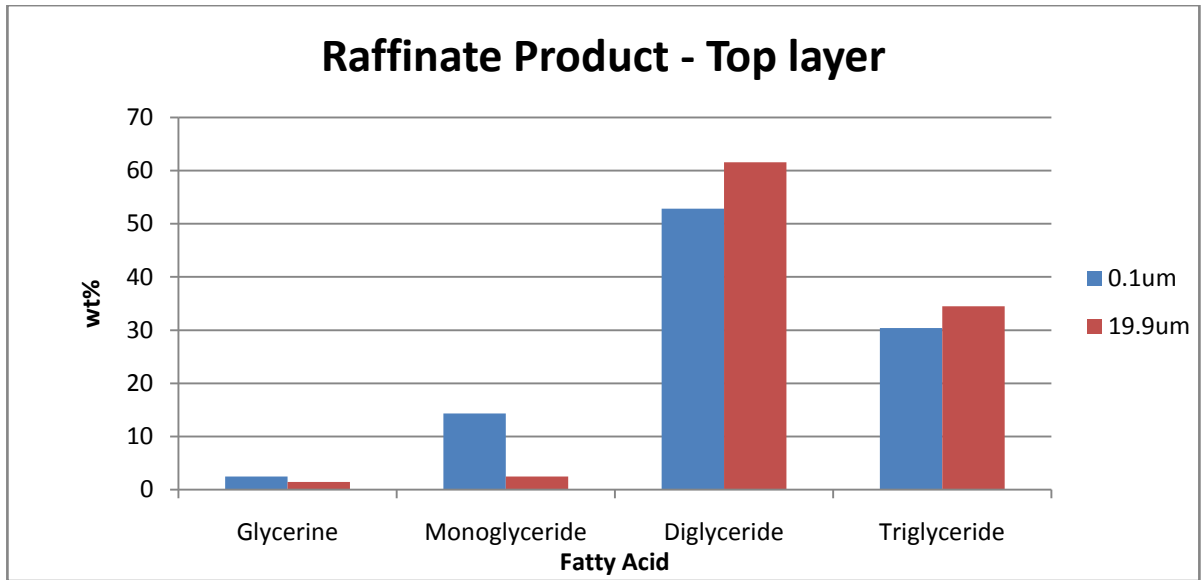
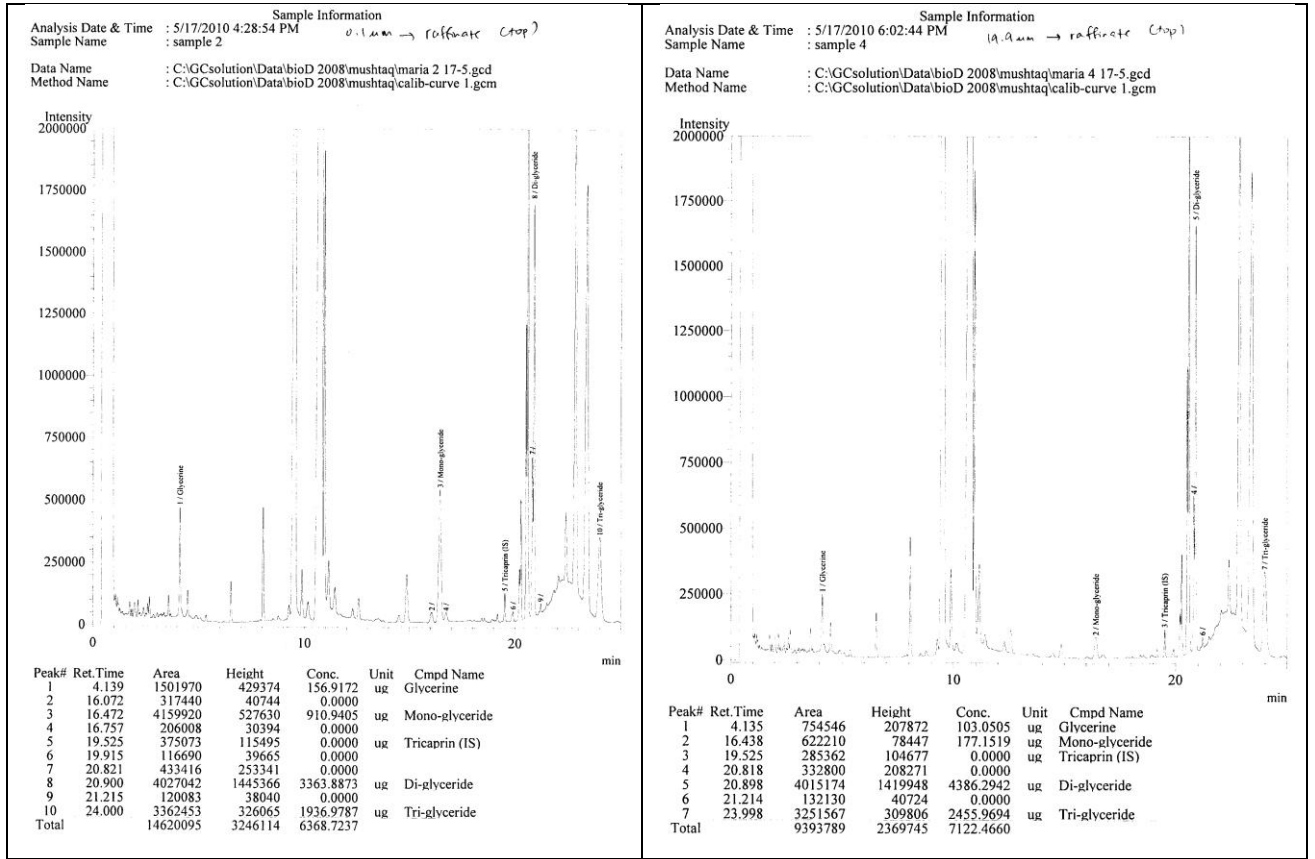

0.1 μ m - Raffinate Product, Top layer

Compound Name	Concentration (mg)	wt%
Glycerine	156.9172	2.463872
Monoglyceride	910.9405	14.30334
Diglyceride	3363.8873	52.81886
Triglyceride	1936.9787	30.41392
Total	6368.7237	100

19.9 μ m - Raffinate Product, Top layer

Compound Name	Concentration (mg)	wt%
Glycerine	103.0505	1.446837
Monoglyceride	177.1519	2.487227
Diglyceride	4386.2942	61.58393
Triglyceride	2455.9694	34.48201
Total	7122.466	100

Permeate product, bottom layer.

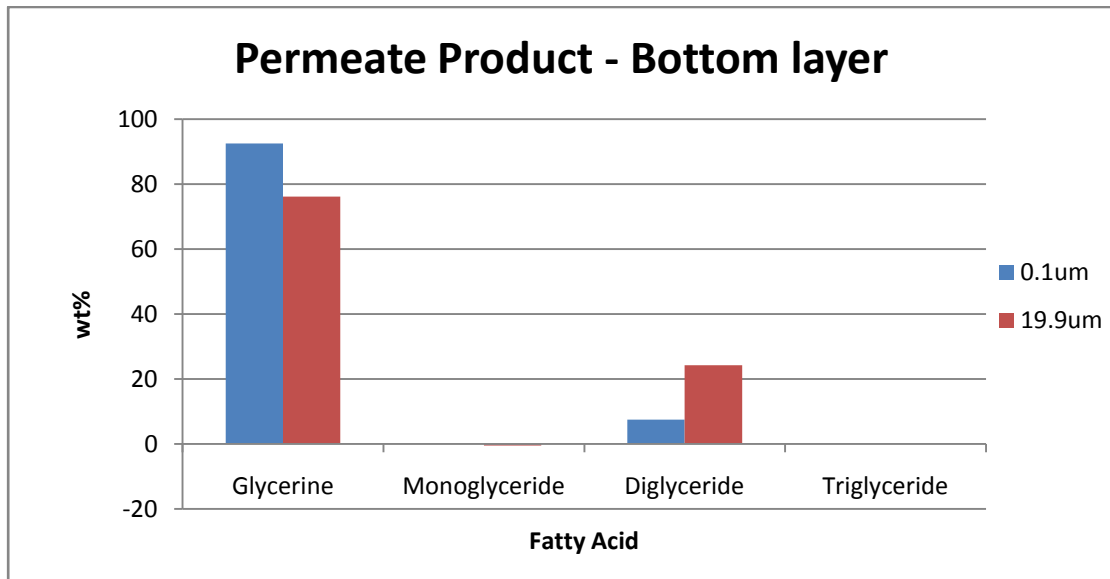
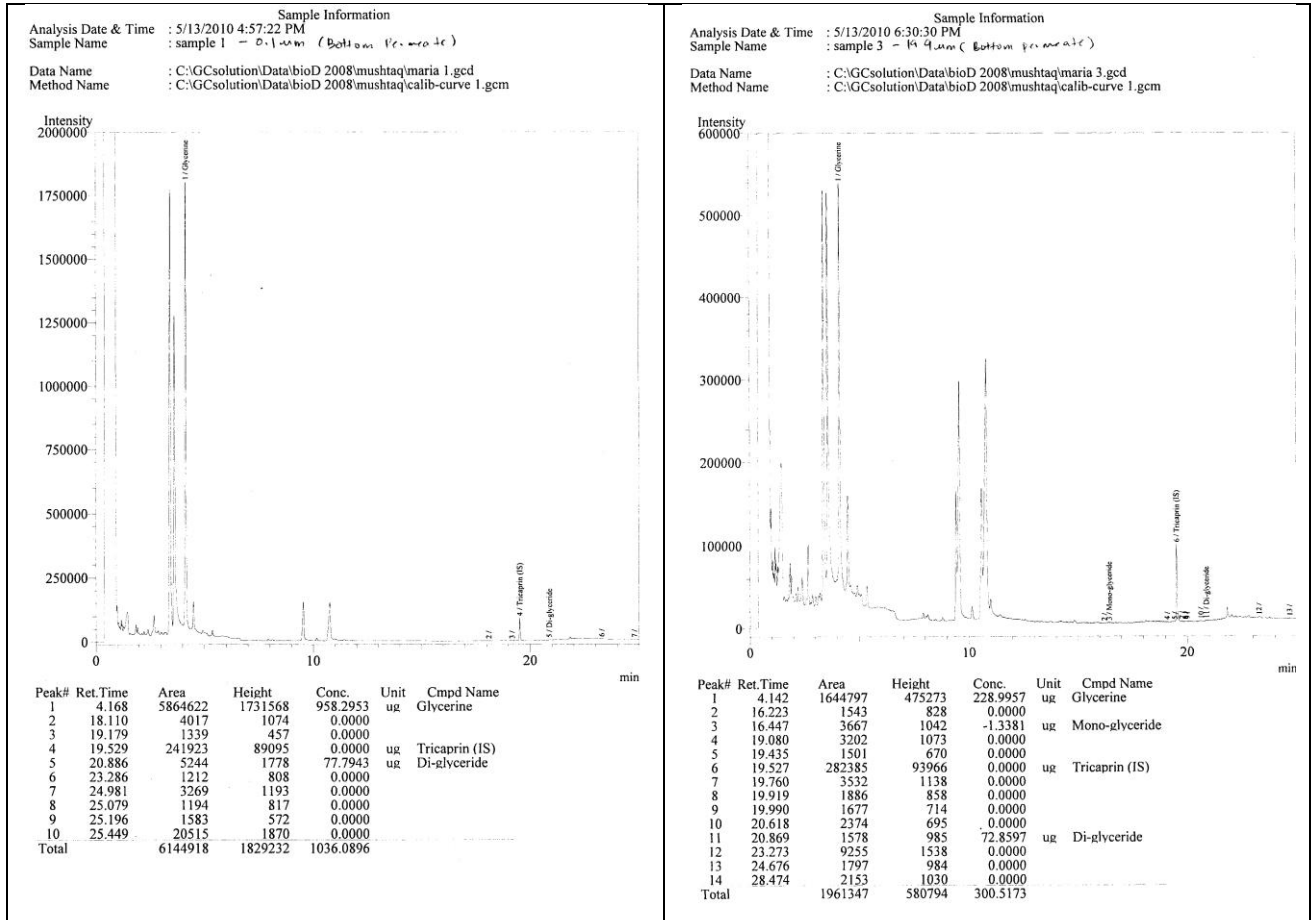

0.1µm - Permeate Product, Bottom layer

Compound Name	Concentration (mg)	wt%
Glycerine	958.2953	92.49155
Monoglyceride	0	0
Diglyceride	77.7943	7.508453
Triglyceride	0	0
Total	1036.0896	100

19.9µm - Permeate Product, Bottom layer

Compound Name	Concentration (mg)	wt%
Glycerine	228.9957	76.2005
Monoglyceride	-1.3381	-0.44527
Diglyceride	72.8597	24.24476
Triglyceride	0	0
Total	300.5173	100

Raffinate product, bottom layer.

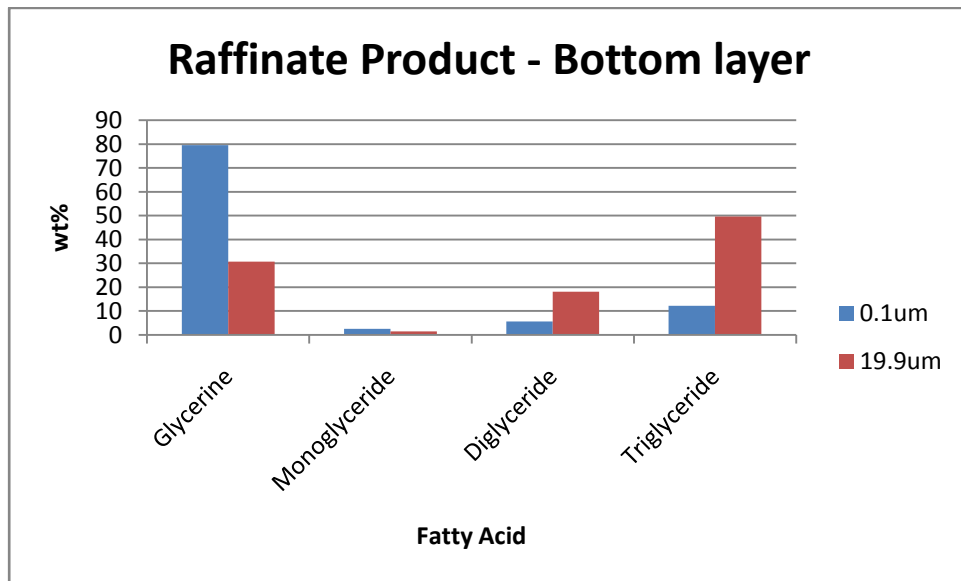
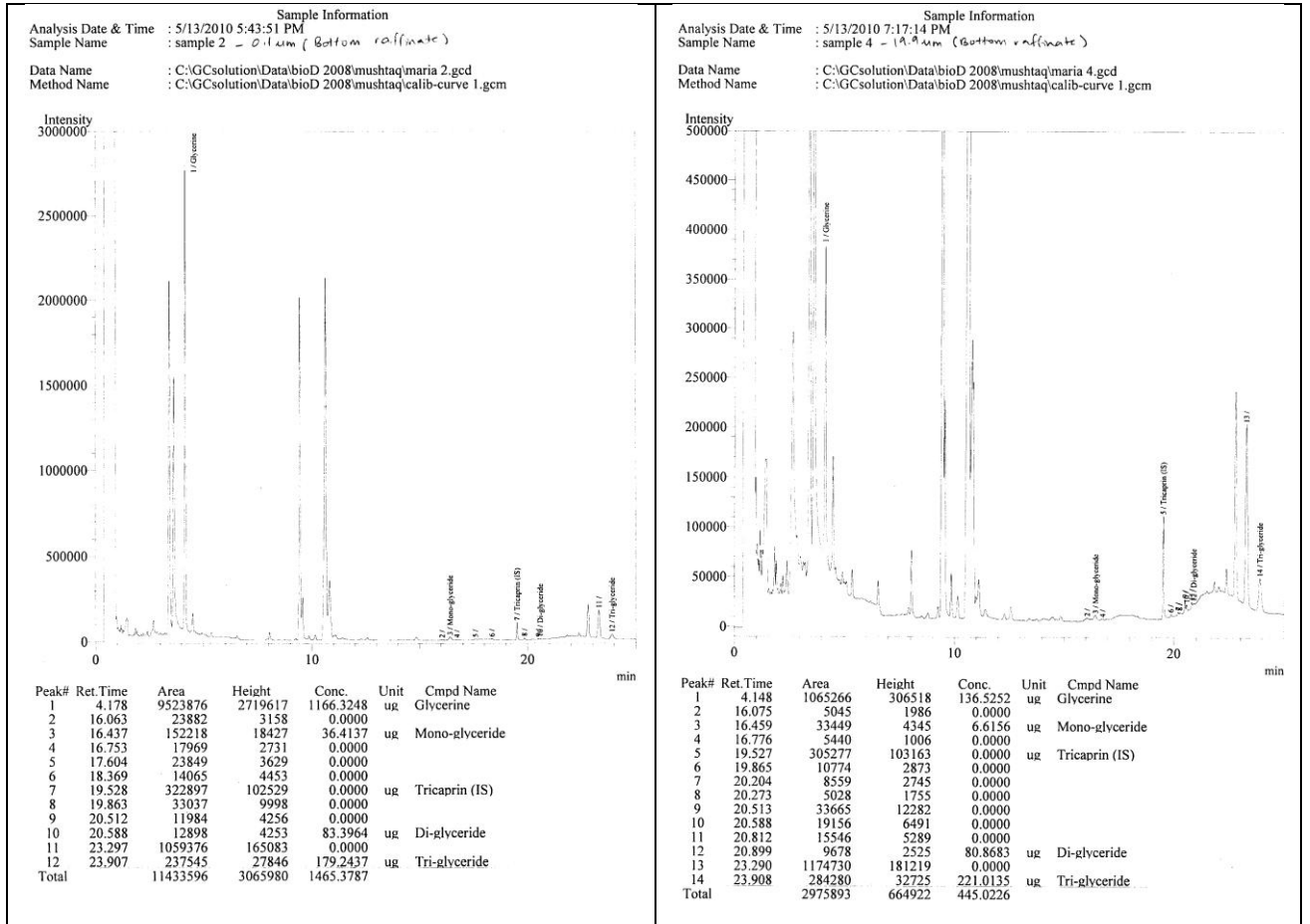

0.1µm - Raffinate Product, Bottom layer

Compound Name	Concentration (mg)	wt%
Glycerine	1166.3248	79.59205
Monoglyceride	36.4137	2.484935
Diglyceride	83.3964	5.691116
Triglyceride	179.2437	12.2319
Total	1465.3786	100

19.9µm - Raffinate Product, Bottom layer

Compound Name	Concentration (mg)	wt%
Glycerine	136.5252	30.67826
Monoglyceride	6.6156	1.486576
Diglyceride	80.8683	18.17173
Triglyceride	221.0135	49.66343
Total	445.0226	100

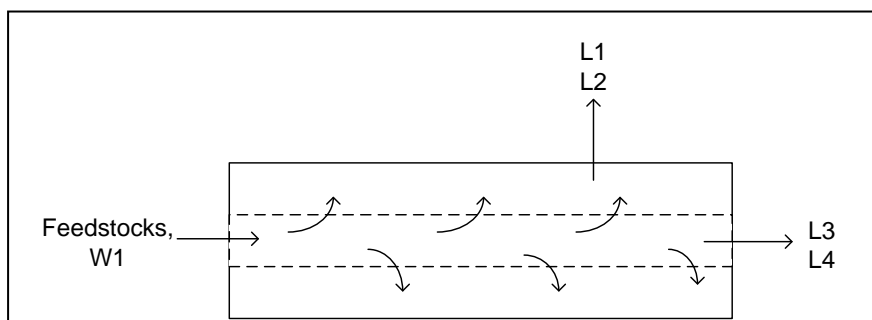

$$\text{Weight of Compounds} = \frac{\text{wt}\%}{100} \times \text{Weight of Sample} \quad \text{Equation 3}$$

0.1µm

W1	247
L1	140.11
L2	11.3
L3	71.1
L4	22.49

0.1µm - Permeate Product, Top layer

Compound Name	Concentration (µg)	wt%	L1 (g)
Glycerine	74.0626	0.945506	1.324748
Monoglyceride	604.2426	7.713946	10.80801
Diglyceride	5682.1973	72.54067	101.6367
Triglyceride	1472.6168	18.79988	26.34051
Total	7833.1193	100	140.11

0.1µm - Permeate Product, Bottom layer

Compound Name	Concentration (µg)	wt%	L2 (g)
Glycerine	958.2953	92.49155	10.45154
Monoglyceride	0	0	0
Diglyceride	77.7943	7.508453	0.848455
Triglyceride	0	0	0
Total	1036.0896	100	11.3

0.1µm - Raffinate Product, Top layer

Compound Name	Concentration (µg)	wt%	L3 (g)
Glycerine	156.9172	2.463872	1.751813
Monoglyceride	910.9405	14.30334	10.16968
Diglyceride	3363.8873	52.81886	37.55421
Triglyceride	1936.9787	30.41392	21.6243
Total	6368.7237	100	71.1

0.1µm - Raffinate Product, Bottom layer

Compound Name	Concentration (µg)	wt%	L4 (g)
Glycerine	1166.3248	79.59205	17.90025
Monoglyceride	36.4137	2.484935	0.558862
Diglyceride	83.3964	5.691116	1.279932
Triglyceride	179.2437	12.2319	2.750955
Total	1465.3786	100	22.49

Feedstocks	247
Permeated Products	151.41
Raffinated Products	93.59
Lost products	2

19.9µm

W1	245
L1	184.45
L2	29.27
L3	13.37
L4	4.17

19.9µm - Permeate Product, Top layer

Compound Name	Concentration (µg)	wt%	L1 (g)
Glycerine	21.8625	0.377458	0.696222
Monoglyceride	167.862	2.898154	5.345645
Diglyceride	4574.5588	78.98021	145.679
Triglyceride	1027.7486	17.74418	32.72914
Total	5792.0319	100	184.45

19.9µm - Permeate Product, Bottom layer

Compound Name	Concentration (µg)	wt%	L2 (g)
Glycerine	228.9957	76.2005	22.30389
Monoglyceride	-1.3381	-0.44527	-0.13033
Diglyceride	72.8597	24.24476	7.096441
Triglyceride	0	0	0
Total	300.5173	100	29.27

19.9µm - Raffinate Product, Top layer

Compound Name	Concentration (µg)	wt%	L3 (g)
Glycerine	103.0505	1.446837	0.193442
Monoglyceride	177.1519	2.487227	0.332542
Diglyceride	4386.2942	61.58393	8.233771
Triglyceride	2455.9694	34.48201	4.610245
Total	7122.466	100	13.37

19.9µm - Raffinate Product, Bottom layer

Compound Name	Concentration (µg)	wt%	L4 (g)
Glycerine	136.5252	30.67826	1.279284
Monoglyceride	6.6156	1.486576	0.06199
Diglyceride	80.8683	18.17173	0.757761
Triglyceride	221.0135	49.66343	2.070965
Total	445.0226	100	4.17

Feedstocks 245

Permeated Products 213.72

Raffinated Products 17.54

Lost products 13.74