

# **Simulation of Flow Characterization in Corrosion Test Rig of Thin Channel Flow Cell (TCFC)**

by

Nor Syazwani Binti Mohd Rafee

14786

Dissertation submitted in partial fulfilment of

the requirements for the

Bachelor of Engineering (Hons)

(Mechanical)

January 2015

Ir. Dr. Mokhtar B Che Ismail

Universiti Teknologi PETRONAS  
Bandar Seri Iskandar  
31750 Tronoh  
Perak Darul Ridzuan

## CERTIFICATION OF APPROVAL

### **Simulation of Flow Characterization in Corrosion Test Rig of Thin Channel Flow Cell (TCFC)**

By

Nor Syazwani Binti Mohd Rafee

14786

A project dissertation submitted to the

Mechanical Engineering Department

Universiti Teknologi PETRONAS

In partial fulfilment of the requirement for the

Bachelor of Engineering (Hons)

Mechanical Engineering

Approved by,

---

Ir. Dr. Mokhtar B. Che Ismail

UNIVERSITI TEKNOLOGI PETRONAS

TRONOH, PERAK

January 2015

## CERTIFICATION OF ORIGINALITY

This is to certify that I am responsible for the work submitted in this project, that the original work is my own except as specified in the references and acknowledgements, and that the original work contained here have not been undertaken or done by unspecified sources or person.

---

NOR SYAZWANI BINTI MOHD RAFEE

## Table of Contents

Abstract .....	1
Chapter 1: Introduction .....	2
1.1 Background of study .....	2
1.2 Problem Statements .....	3
1.3 Objectives .....	3
1.4 Scope of Study.....	3
Chapter 2: Literature Review .....	4
2.1 Factors that affect corrosion .....	4
2.2 Study on Flow Dynamics .....	8
2.2.1 Type of flow .....	8
2.2.2 Reynolds number .....	11
2.2.3 Shear Stress .....	12
2.2.4 Flow rate.....	15
2.3 CFD Simulation Analysis.....	16
2.3.1 Simulation of pipe elbow flow .....	16
Chapter 3: Methodology .....	17
3.1 Project Methodology .....	17
3.2 Simulation Methodology .....	19
3.3 Flow chart.....	24
3.4 Project Timeline .....	25
3.5 Project Key-Milestone.....	26
Chapter 4: Results and Discussion .....	27
4.1 Modelling fluid in ANSYS Fluent .....	27
4.1.1 Geometry of models .....	27
4.1.2 Meshing.....	28
4.2 Setup for model - Simulation solution method, calculations and assumptions .....	31
4.3 Simulation results .....	32
4.4 Analytical Calculation .....	38
4.5 Discussions .....	40
4.5.1 Graph and percentage error .....	40
4.5.2 Uniformity of velocity on corrosion coupons .....	43

Chapter 5: Conclusions and Recommendation .....	45
5.1    Conclusions .....	45
5.2    Recommendation.....	46
References .....	47

## List of Figures

Figure 1: Pitting Corrosion .....	5
Figure 2: Overall view of Thin Channel Flow Cell (TCFC) system.....	7
Figure 3: Rectangular cell for TCFC .....	7
Figure 4: Shearing force, $F$ , acting on a fluid element.....	8
Figure 5: Velocity profile in a pipe.....	9
Figure 6: Fluid element under a shear force .....	9
Figure 7: Streamlines when laminar flow and turbulent flow occur.....	10
Figure 8: Diagram of flow regimes in pipe flow .....	10
Figure 9: The contours of velocity (a) and wall shear stress (b) at the elbow .....	16
Figure 10: CFD Fluent simulation process .....	19
Figure 11: Overall view of the model .....	20
Figure 12: Model for simulation purpose (Top view).....	21
Figure 13: Model for simulation purpose (Side view).....	21
Figure 14: Flow chart for simulation .....	24
Figure 15: Model for CFD Fluent Simulation .....	27
Figure 16: Aspect ratio.....	28
Figure 17: Element quality.....	29
Figure 18: Meshing of the model.....	30
Figure 19: Solution methods used for this simulation .....	31
Figure 20: Water velocity in the TCFC at 5 gpm .....	33
Figure 21: Water velocity in the TCFC at 10 gpm .....	33
Figure 22: Water velocity in the TCFC at 15 gpm .....	34
Figure 23: Water velocity in the TCFC at 20 gpm .....	34
Figure 24: Water velocity in the TCFC at 25 gpm .....	35
Figure 25: Water velocity in the TCFC at 30 gpm .....	35
Figure 26: Water velocity in the TCFC at 35 gpm .....	36
Figure 27: Water velocity in the TCFC at 40 gpm .....	36
Figure 28: Water velocity in the TCFC at 45 gpm .....	37
Figure 29: Water velocity in the TCFC at 50 gpm .....	37
Figure 30: Velocity in the TCFC graph .....	40
Figure 31: Wall shear stress in TCFC graph.....	41
Figure 32: Arrangement of corrosion coupons in TCFC .....	43
Figure 33: Current assumption.....	46
Figure 34: Recommended assumption.....	46

## List of Tables

Table 1: Gantt chart of Final Year Project I.....	25
Table 2: Gantt chart of Final Year Project II .....	26
Table 3: Engineering details of Thin Channel Flow Cell (TCFC).....	27
Table 4: Calculated velocities in pipe and TCFC .....	32
Table 5: Velocities obtained during simulation .....	38
Table 6: Wall shear stress for both calculated velocity and velocity obtained during simulation in TCFC.....	39
Table 7: Percentage error of velocity .....	41
Table 8: Percentage error of velocity .....	42
Table 9: Velocity difference across each corrosion coupon .....	43

## **Abstract**

Pipeline corrosion can cause major integrity issue in oil and gas industry. The corrosion mechanism is influenced by many factors such as operating pressure, temperature, pH and flow condition. An experimental tool known as Thin Channel Flow Cell (TCFC) is introduced recently, which can be used to determine corrosion rate. A uniform flow pattern across the corrosion coupons in the TCFC is assumed throughout every experiment. A simulation of flow characterization is developed to analyse the velocity and the uniformity of velocity profile on the corrosion coupons in TCFC when flow rates are varied. Computational Fluid Dynamics – Fluent (CFD – Fluent) by Ansys is used to identify the flow pattern across corrosion coupons inside TCFC. CFD – Fluent consists of few steps which are modelling of geometry, meshing, setting up of solutions and last but not least, the simulation results. As a result, the velocity in the TCFC during simulation and calculation vary but still within the acceptable range which is less than 20 %. Apart from that, types of flow develop at different flow rates in TCFC are concluded to be turbulent as stated in Table 4. As the flow rate increases, the wall shear stress developed across all the corrosion coupons also change.



# Chapter 1: Introduction

## 1.1 Background of study

Corrosion can be defined as a process of degradation of a certain materials such as metals and ceramics due to its reactions with the environment. In this form of degradation, corrosion can actually cause major problems such as plant shutdowns, waste of valuable resources, reduction in efficiency and expensive overdesign.

Corrosion can be classified in many types which are uniform corrosion, selective corrosion, intergranular corrosion and carbon dioxide corrosion. For instance, carbon dioxide corrosion is proven to be more dangerous than uniform corrosion. In the oil and gas industry, these three gases (carbon dioxide, hydrogen sulphide and free water) are highly corrosive. Then if these gases are not removed from the pipelines, the internal pipelines will suffer from corrosion effects.

For a certain process to occur, there are few factors involved. As for corrosion, there are a lot of factors that affecting corrosion rate such as pH, temperature, pressure and type of flow develops in the pipelines. The effect of flow on corrosion is usually simulated and studied using Rotating Cylinder Electrodes (RCE) at ambient pressure and temperature. The shear stress acting on its corrosion coupon is calculated by using theoretical formula at different flow rates. However, the flow simulation is done with just having assumptions.

In this project, flow characterization that develops on the corrosion coupons in Thin Channel Flow Cell (TCFC) are to be analysed. The velocity and the uniformity of the velocity across the corrosion coupons are dependent on the flow rates that flows in the TCFC. A simulation method was conducted to identify the real velocity that flows on the coupons at different flow rates which was compared to the calculated velocity. Here, the calculated velocity and velocity obtained during simulation was used to calculate the shear stress.

## **1.2 Problem Statements**

Thin Channel Flow Cell (TCFC) is recently introduced as a potential experimental tool to study the flow effect on coupons. A uniform flow pattern across the corrosion coupons in the TCFC is assumed throughout every experiment. A simulation of flow characterization needs to be developed to analyse the velocity and the uniformity of velocity on the corrosion coupons in TCFC when flow rates are varied.

## **1.3 Objectives**

The objectives of this study is to characterize the flow pattern acting on the corrosion coupons located on the surface of Thin Channel Flow Cell (TCFC)

- To develop fluid modelling of TCFC
- To characterize the flow pattern in TCFC with variable of flow rates
- To do correlation between the wall shear stress calculated by using velocities that are obtained from simulation and wall shear stress calculated by using calculated velocities

## **1.4 Scope of Study**

The scope of study of this project title, ‘Simulation of Flow Characterization in Corrosion Test Rig of Thin Channel Flow Cell (TCFC)’, is as follows;

- To develop a model to see the generation of flow at different flow rates
- To characterize the flow development at different flow rates

## Chapter 2: Literature Review

### 2.1 Factors that affect corrosion

The effect of corrosion in oil and gas industry is a serious problem as it leads to major destructions especially to the pipelines. As mentioned by Popoola (2013), corrosion is the destructive attack of a material by reaction with its environment and a natural potential hazard associated with oil and gas production and transportation facilities. The process involves three elements which are an anode, a cathode and an electrolyte. Anode is usually the site of the corroding metal while electrolyte is the corrosive medium that enables the transfer of electrons from anode to cathode, and last but not least is a cathode that forms the electrical conductor that is not consumed in the corrosion process.

As per discussed earlier in the introduction, corrosion rate is affected by many factors such as temperature, pH, pressure and type of flows which develop in the pipelines. For temperature effect, Zhang (2011) points out that, at the temperature of 40°C to 80°C, the change in corrosion rate was quite significant as the gas temperature increased. At relatively low gas temperature range, condensation rate affects the corrosion rate. While at higher temperature, the corrosion scale formation becomes the key factor in controlling the corrosion process. Similar case mentioned by Chang (2012) with the title of research paper 'Effect of Temperature on Wet Carbon Dioxide of Pipeline Steel', the corrosion rate of the pipeline increased when the temperature of wet gas is also increased and when the temperature difference between pipe wall and wet gas is larger, it leads to a higher condensation rate which contributes to the increase of corrosion rate.

Besides that, Popoola (2013) claim that crude oil and natural gas contain some highly corrosive substances such as carbon dioxide, hydrogen sulphide and free water, which affect the life span of process facilities and the internal pipe of the pipelines. Apart from that, it also creates pitting corrosion in the pipelines caused by sweet corrosion with the presence of carbon dioxide. Sweet corrosion happens when dry carbon dioxide is dissolved in an aqueous phase which can promote an

electrochemical reaction between steel and contacting aqueous phase. Carbon dioxide will mix with water, then forming carbonic acid in producing the acidic fluid.



Figure 1: Pitting Corrosion

Corrosion rate is affected by pH as well, as what had been mentioned by Tanupabrungsun (2013) in his research paper of ‘Effect of pH on Carbon Dioxide of Mild Steel at elevated temperatures’, when he conducted an experiment to test the effect of pH over a temperature range of 80 – 200 °C. He has found out that the corrosion rates at pH 4.0 are higher than those at pH 6, and at temperature above 120°C, the corrosion rate decreases with time due to formation of corrosion products.

To analyse how flow affecting the corrosion rate, a journal that uses flow-accelerated corrosion (FAC) of an X65 pipeline steel was analysed which is by Zhang (2010). He mentioned that, when flow velocity and shear stress increase, it would get thinner, degrade or remove completely the scale which increases the corrosion rate of the steel. In addition to this, both oblique impact and normal impact were investigated too. An oblique impact of fluid generally gives a high corrosion rate of the steel; while at the normal impact, it have low flow velocity and shear stress which leads to low mass transfer rate.

According to Liang (2013) who has successfully conducted an experiment to observe the effect of flow rates on corrosion rate of cast iron, he concluded that corrosion rate increased with the increment of flow rates, as a result of decreasing the path of oxygen diffusion through laminar flow layer adjacent to the coupon surface. He then added such phenomenon was confirmed by the observation of rougher coupon surface after cleaning at higher than at lower flow rate.

In addition, a study from Peng (2013) on the CFD wall shear stress benchmark in stratified-to-annular transitional flow regime has stated that the wall shear stress is an important parameter in corrosion models. As corrosion inhibitor removal from the wall increases with increasing wall shear stress, hence, accelerates the corrosion rates. This is closely related to the intensity of turbulence in the fluid acting on the wall. To understand further about this force, it is actually not a force on the wall from the flowing fluid but a force within the flowing fluid at the wall. Therefore, flow behaviour needs to be taken into account for an adequate corrosion prediction.

TCFC has a special rectangular cell where corrosion rates are calculated using X65 (mild steel) probes. The effect of flow rates on corrosion rates in pipelines can be slightly different with the result shown by TCFC as they are using a rectangular cell to conduct a corrosion test. The manufacturer informed that the type of flow during corrosion test is well developed, but this information is still needs to be further clarified by using CFD method.

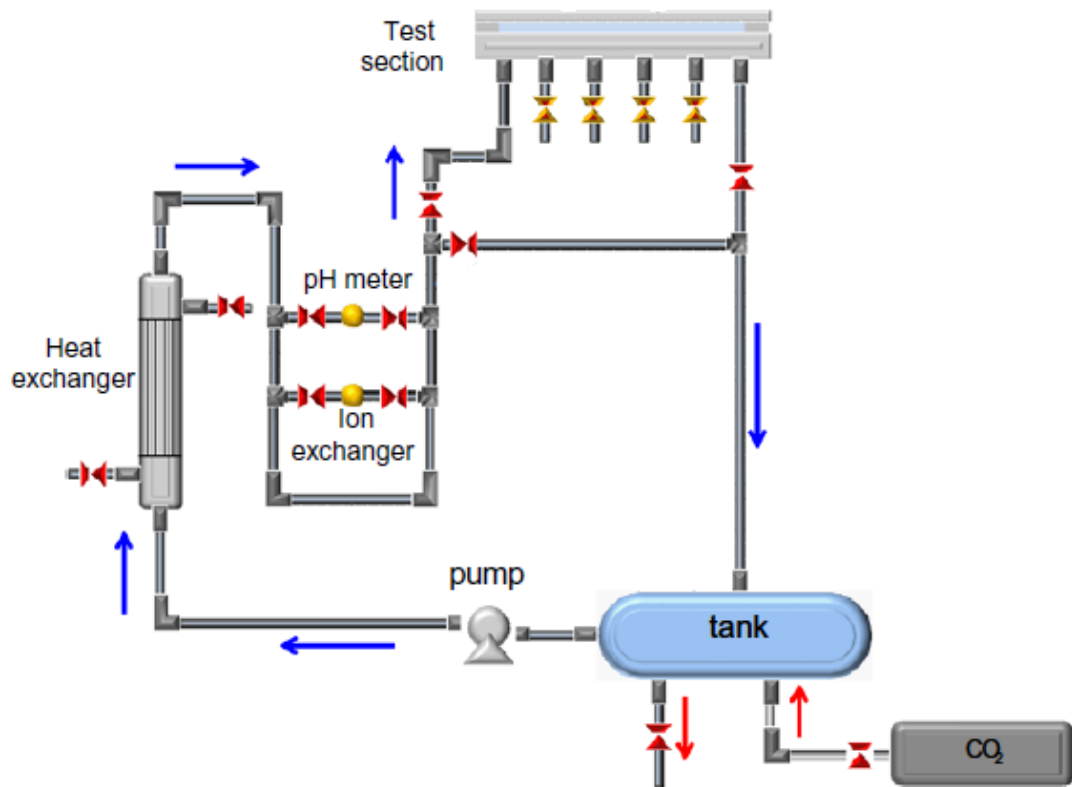

Figure 2: Overall view of Thin Channel Flow Cell (TCFC) system

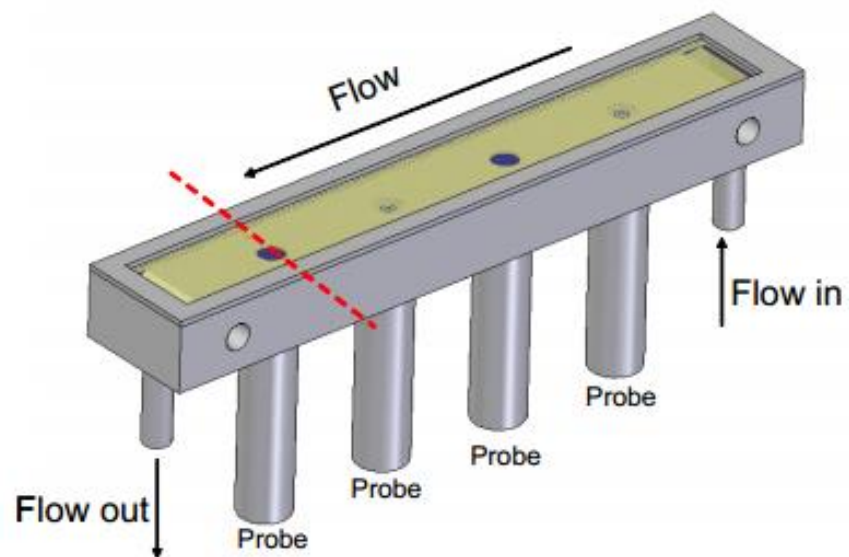

Figure 3: Rectangular cell for TCFC

## 2.2 Study on Flow Dynamics

### 2.2.1 Type of flow

Study on the factors that affecting corrosion has been explained in the previous part, thus this project is basically focusing on the study of flow dynamics. Normally three states of matter which are solid, liquid and gas are studied. However, liquid and gas are both fluids which are unlike solids. They lack the ability to resist deformation, hence, fluid moves and flows under action of the force because it cannot resist this deformation force. The deformation is caused by shearing forces which act tangentially to a surface. As what we can see below, force  $F$  acting tangentially on a rectangular element. This is called as shearing force which produces the dashed lines.

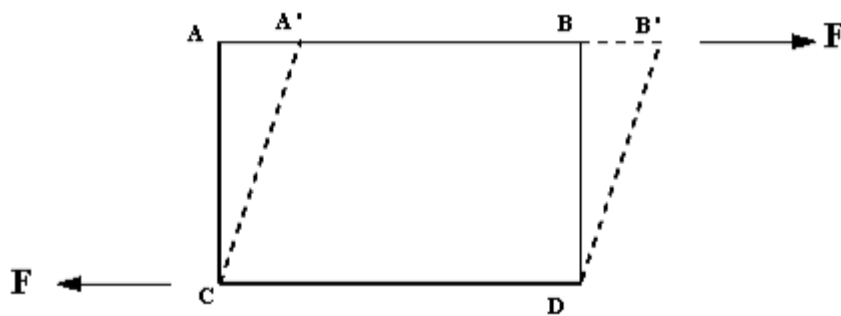

Figure 4: Shearing force,  $F$ , acting on a fluid element

When a fluid is in motion, shear stresses are developed, if the particles of the fluid move relative to one another. Different velocities will occur at adjacent particles when this happens, but the particles have zero relative velocity if velocity is the same at every point, hence, no stress shear is produced. For instance, if we were to consider the flow in a pipe in which water is flowing, the velocity of the water at the pipe wall will be zero. As we move towards the centre of the pipe, the velocity will increase. The change in velocity across direction of flow is called velocity profile. Shear forces in the moving fluid is produced as the particles of fluid next to each other are moving with different velocities.

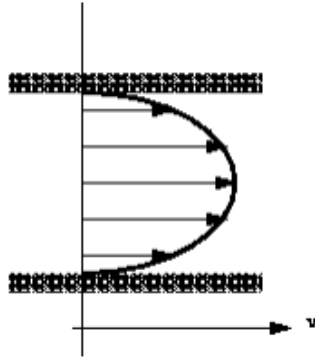

Figure 5: Velocity profile in a pipe

To relate with viscosity, a 3D rectangular element of fluid is observed. The shearing force  $F$  acts on the area on top of the element which the area is given by equation,  $A = \delta s \times \delta x$ . A formula to calculate shear stress is created by using this formula, which is equal to force per unit area, *shear stress*,  $\tau = \frac{F}{A}$ . The deformation which this shear stress causes is calculated by the size of angle  $\phi$  and is known as shear strain, which in a fluid,  $\phi$  increases for as long as  $\tau$  is applied when fluid flows. In addition to this, the rate of shear stress is actually directly proportional to the shear stress. If the particle at point  $E$  moves under shear stress to point  $E'$  and it takes  $t$  to make it happen, it has moved the distance  $x$ . So, we can write the small deformations as *shear strain*,  $\phi = \frac{x}{y}$  and *rate of shear strain* =  $\frac{\phi}{t} = \frac{u}{y}$  where  $\frac{x}{t} = u$  is the velocity of the particle at  $E$ . Hence, the constant of proportionality is known as the dynamic viscosity,  $\mu$ , of the fluid and  $\tau = \mu \frac{du}{dy}$ .

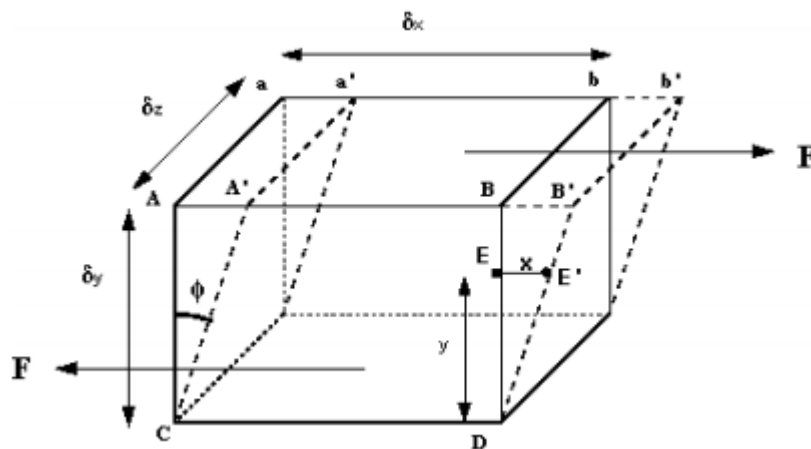

Figure 6: Fluid element under a shear force



Types of flow can be divided into two, which is laminar flow or turbulent flow. And to determine this, Reynolds Number ( $Re$ ) which is dimensionless needs to be calculated theoretically.  $Re$  is the ratio of inertial forces to viscous forces and is given by the formula,  $Re = \rho V D / \mu$ . It is said that when  $Re$  is less than 2000, it is considered as laminar; while if  $Re$  is more than 4000, turbulent occurs. Transition flow also might happen if  $Re$  is more than 2000 but less than 4000. Laminar flow is where the fluid in pipe moves slowly in layers, without much mixing among the layers. This typically occurs when the velocity is low or the fluid is very viscous. When the flow is laminar, the streamlines are parallel and we may consider the flow between two parallel surfaces as made up of parallel laminar layers. Unlike turbulent flow, considerable mixing occurs where velocities are high. The shearing process causes energy loss and heating of the fluid. When a certain critical velocity is exceeded, the streamlines break up and mixing of the fluid happens.

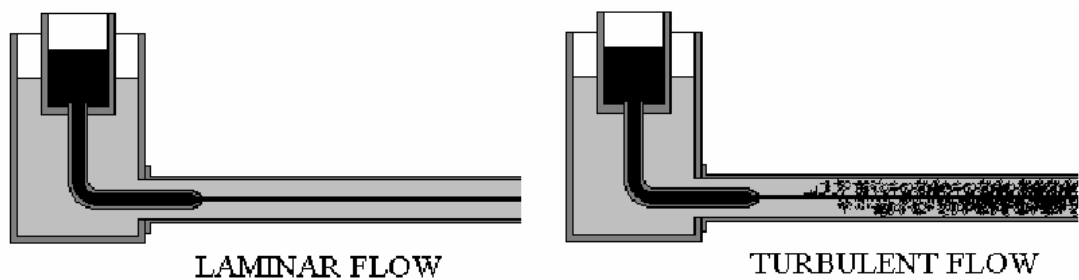

Figure 7: Streamlines when laminar flow and turbulent flow occur

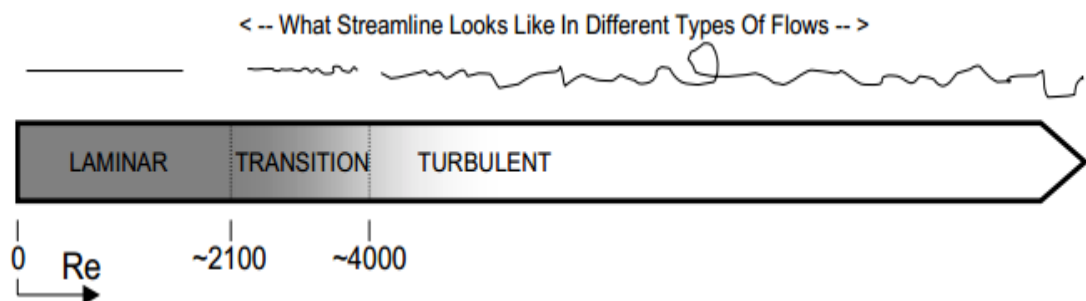

Figure 8: Diagram of flow regimes in pipe flow

### 2.2.2 Reynolds number

Reynolds number in different channels such as in a pipe or rectangular duct has a slight difference. For a pipe, Reynolds number is generally defined as,

$$Re = \frac{\rho VD}{\mu} = \frac{VD}{\nu} = \frac{QD}{\nu A} \text{ (Eq. 1)}$$

Where:

V = Mean fluid velocity (m/s)

D = Diameter (m)

$\mu$  = Dynamic viscosity of the fluid (N.s/m<sup>2</sup>)

$\nu$  = Kinematic viscosity ( $\nu = \mu/\rho$ ) (m<sup>2</sup>/s)

$\rho$  = Density of the fluid (kg/m<sup>3</sup>)

Q = Volumetric flow rate (m<sup>3</sup>/s)

A = Pipe cross-sectional area (m<sup>2</sup>)

Unlike in a rectangular cell, Reynolds numbers can be calculated by using the equation as follows:

$$Re = \frac{VL}{\nu} = \frac{\rho VL}{\mu} \text{ (Eq. 2)}$$

Where:

V = velocity of the fluid (m/s)

L = the characteristic length of the hydrodynamic system (m)

$\nu$  = kinematic viscosity of the fluid (m<sup>2</sup>/s)

$\rho$  = density of the fluid (kg/m<sup>3</sup>)

$\mu$  = dynamic viscosity of the fluid (kg/m.s)

### 2.2.3 Shear Stress

In Rotating Cylinder Electrodes (RCE), it is proven that the turbulent flow induces a wall shear stress on the surface of the cylinder. Using equation 3, wall shear stress acting on the surface of cylinder can be calculated.

$$\tau_{cyl} = 0.0791 \times \rho \times R^{-0.3} \times U_{cyl}^2 \text{ (Eq. 3)}$$

Where:

U = the flow velocity (m/s)

$\rho$  = density of the fluid (kg/m<sup>3</sup>)

Re = Reynolds number

Similarly in Thin Channel Flow Cell (TCFC), identifying wall shear stress is very important to analyse the corrosion rate on corrosion coupon. Based on Yang (2010) in his paper, he explained that in CO<sub>2</sub>-corrosion environment, the hydrodynamic wall shear stress can mechanically damage a protective layer with the presence of turbulent flow. In this study, TCFC was used to test corrosion rate of certain materials such as steel. As mentioned by Li (2014) in his paper titled 'Effect of wall shear stress on sour corrosion of carbon steel', wall shear stress is an important environmental parameter which explains the interaction of the flowing fluid with the steel surface. According to Schmitt (2011), wall shear stress is usually measured in [N/m<sup>2</sup>] or [Pa], which describes the friction between the fluid and the wall in channel.

$$\tau = \mu \frac{du}{dy} \quad (\text{Eq. 4})$$

Where:

$\mu$  = the hydrodynamic viscosity (N/m<sup>2</sup>)

$u$  = the flow velocity (m/s)

$y$  = the distance from the wall (m)

Akeer (2014) found that TCFC provides realistic flow conditions with simpler operation compared to large scale systems, and is manufactured for corrosion testing and also for high shear stress flow. There are two different methods used to determine wall shear stress, which are by measuring the pressure drop between two points and by calculating Reynolds number first (equation 5, 6 and 7).

$$\tau = \frac{(p_1 - p_2) \times 100000 \times h \times w}{(2 \times (h+w) \times l)} \quad (\text{Eq. 5})$$

$$C_f = 0.073 \times Re_h^{-0.25} \quad (\text{Eq. 6})$$

$$Re = \frac{h \times v \times \rho}{\mu} \quad (\text{Eq. 7})$$

$$\tau = \frac{C_f \times \rho \times v^2}{2} \quad (\text{Eq. 8})$$

Where:

$\tau$  = wall shear stress at the wall (Pa)

$v$  = fluid velocity in the TCFC (m/sec)

$\rho$  = density of the fluid (kg/m<sup>3</sup>)

$\mu$  = viscosity of the fluid (kg/m.s),

$p_1$  = measured upstream pressure (Pa)

$p_2$  = measured downstream pressure (Pa)

$h$  = height of TCFC channel (m)

$w$  = width of TCFC channel (m)

$l$  = length between  $p_1$  and  $p_2$  in the TCFC (m)

Re = Reynolds number

#### 2.2.4 Flow rate

Flow rate is equal to area of flow multiplies the velocity of flow. When it comes to giving units for certain conditions, cubic feet per second (ft<sup>3</sup>/s) is usually used for flows in rivers, streams and large pipes while gallons per minute (gallons/min) is often used for smaller flow rates such as well production and flow through smaller pipe systems. As for TCFC system, it is considered to be a small system since the shear stress can be as low as 1.1 Pa as mentioned in a paper by Farelas (2009).

According to this one journal titled ‘Computer Applications in Hydraulic Engineering’ (2002), it is stated that the formula for flow rate is as follows:

$$V = Q/A \text{ (Eq. 9)}$$

Where:

V = average velocity (m/s)

Q = flow rate (m<sup>3</sup>/s)

A = area (m<sup>2</sup>)

## 2.3 CFD Simulation Analysis

A simulation can be done for different type of channel such as in a straight pipe, elbow pipe and even in a rectangular-shaped cell with various analysis that can be obtained. In this case, flow development such as velocity and pressure profiles raised the most concern with a fluid type of water.

### 2.3.1 Simulation of pipe elbow flow

According to Zeng (2013) investigated the effect of corrosion rate at the elbow of carbon steel pipeline, he concluded that the corrosion rate at the inner wall of the elbow is higher than at the outer wall of elbow with the higher flow velocity and shear stress at the inner wall. The maximum corrosion rate is discovered at innermost side of the elbow which the location with the maximum flow velocity and shear stress, while the minimum corrosion rate is discovered at outermost side of the elbow which the location with minimum flow velocity and shear stress.

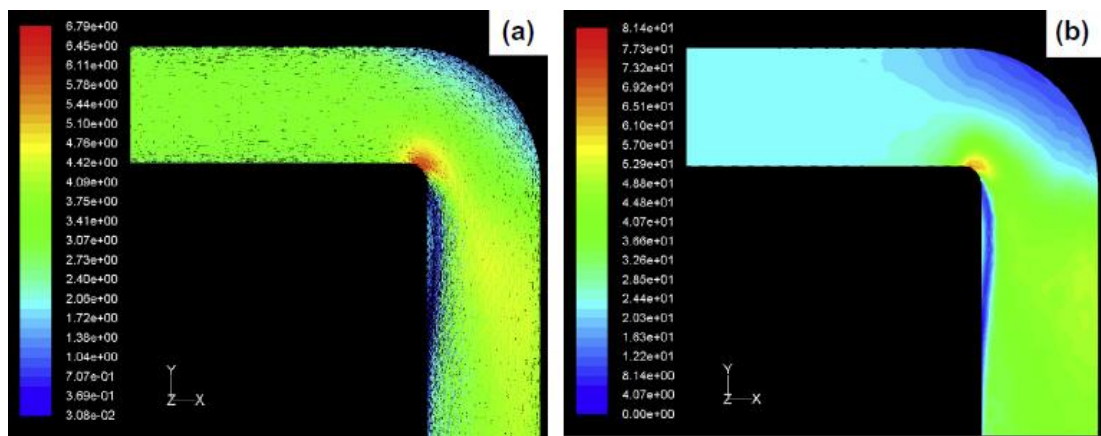

Figure 9: The contours of velocity (a) and wall shear stress (b) at the elbow

This conclusion can be considered reliable as Homicz (2004) also concluded that the maximum wall shear occurs on the inside radius of the elbow. But initially, he assumed that the maximum corrosion would occur on the outside radius of the bend, but his simulation had proved the assumption was wrong.

## **Chapter 3: Methodology**

### **3.1 Project Methodology**

The following are the methodology planned to achieve the objectives;

#### **I. Identifying the problem**

- a. Before a research begins, a specific problem needs to be identified in order to direct the research to a more accurate target. For this project, the main concern is to analyse the real flow development that develops inside the thin channel rather than just having analytical calculation about the flow development which is the wall shear stress.

#### **II. Identifying the objective and scope of study**

- a. A specific objective needs to be linked to the problem identified thus that a more accurate goal can be achieved. Also, the scope of the study needs to be set in order to specify the research.
- b. In this project, the objective is to develop a modelling which is almost similar to the TCFC, to simulate and analyse the real flow development inside the thin channel. The result will then be compared to the analytical calculations.

#### **III. Data Collection**

- a. Data need to be gathered as much as possible from all sort of sources such as thesis, journals, research papers and conference papers before a simulation begins. For the modelling part, the dimensions and engineering details of the model will be gathered from corrosion centre including few data such as minimum and maximum of flow rate.



#### IV. Designing and simulating the flow thin channel

- a. From the data collected, a model which is similar to the real machine needs to be proposed. The dimensions are more or less has to be similar to the real one. Two models need to be developed which are the overall view and for simulation purposes. A simulation is then to be conducted using Ansys programs, specifically CFD Fluent. During simulations, different velocities at the inlet will be varied by varying the flow rates.

#### V. Data Interpretation

- a. The received data during the simulation need to be compared to the analytical calculations to make sure the received data is reliable.

#### VI. Conclusion and Recommendations

- a. Based on the output of the simulation and also the analytical calculations, a conclusion is then will made to analyse whether the result that were obtained are correct and reliable.

### 3.2 Simulation Methodology

The simulation tool used is ANSYS Fluent. In this section, the steps will be explained briefly on how to simulate the model. The steps include modelling, meshing, simulation and the end result of the simulations. The flow development is expected to be fully developed.

The general step of CFD process is explained in the chart below:

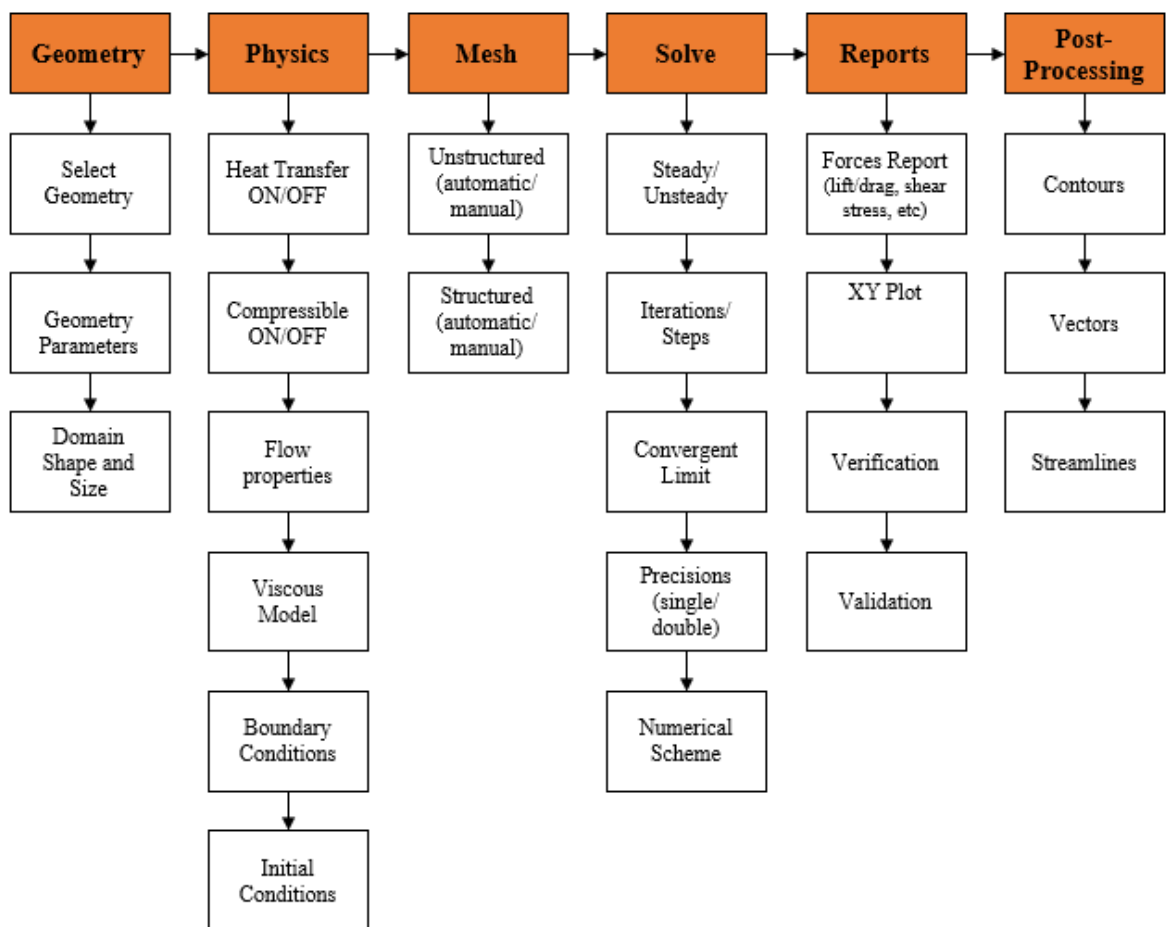

Figure 10: CFD Fluent simulation process

A detailed description of some important parts in CFD process such as modelling of geometries, meshing of the geometries, setup of the parameters and solution and last but not least, the result of simulation are explained.

### **Step 1: Modelling the geometries**

For this project, two models are expected to be developed. One model is for the overall view of the model including the dimensions and the other model is for simulation. For simulation, a specific model need to be constructed only to have the shape where the fluid flows. From here, the flow development is easier to identify.

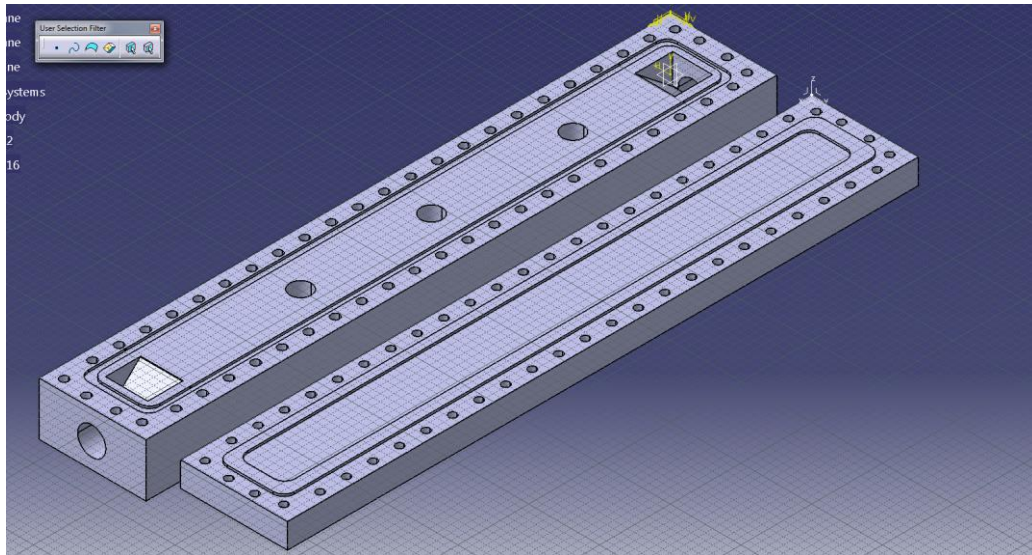

Figure 11: Overall view of the model

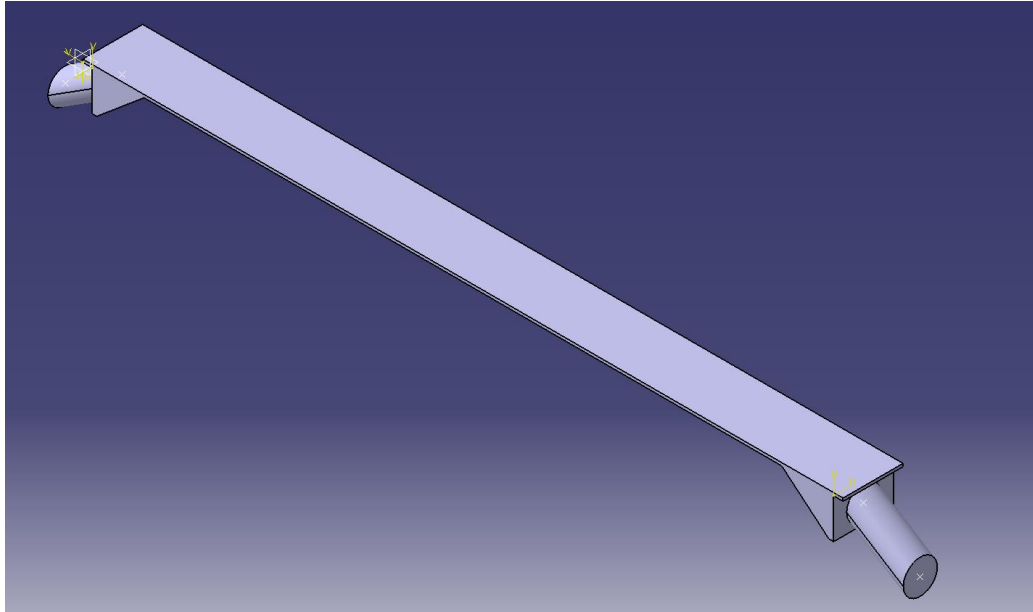

Figure 12: Model for simulation purpose (Top view)

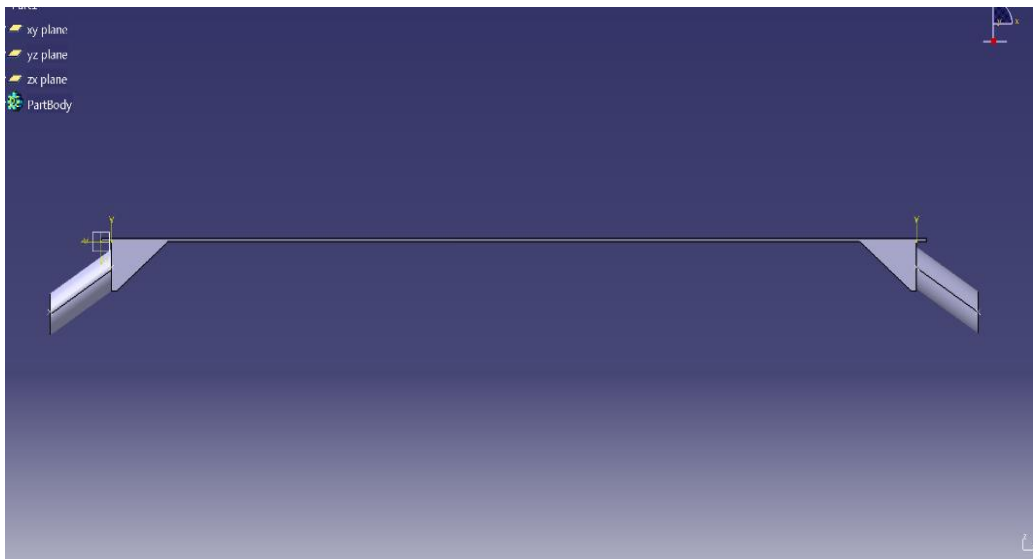

Figure 13: Model for simulation purpose (Side view)

## **Step 2: Meshing the geometry**

Meshing is one of the most important aspects of the simulation as it will determine the accuracy of the simulation. The more numbers of cell created on the geometry, the more accurate it will be. Nevertheless, it will take a longer time to get the simulation done if the meshing is very fine and set to be high quality.

For the setup of meshing, the Advance Size Function to Proximity and Curvature is chosen as all of the geometries used have a curvature and a degree of inclination. This means that at the curve, the meshing will be more accurate and will create cells with angles.

For the method of meshing, Cut Cell method is used for simulation to increase the percentage of accuracy by creating hexahedral cells. Inflation is also added to create a better meshing at fluid with are near the pipe wall. As mentioned in CFD simulation of void flow in ECCS by Wang (2013), inflation was added to his particular inlet and outlet model to enhance the element quality of the model.

In order to know the accuracy and the quality of the meshing, two main criteria that need to be taken into account is the Aspect Ratio and also the Element quality. These two aspects will be explained further at Chapter 4 of this report.

### **Step 3: Setup of the parameters and solution**

After meshing completed, the parameters need to be inserted. The gravity is to be inserted with a value of  $-9.81 \text{ m/s}^2$ , as this is an important aspect of the simulation. For this simulation, water with a density of  $998 \text{ kg/m}^3$  in fluid database is selected.

Since the model has the inlet and outlet sections, flow rate will be varied at the inlet with the range of 0 to 50 gpm. Nonetheless, velocity is inserted at the inlet instead of flow rate. Different flow rate will leads to different inlet velocity, this is where analytical calculation takes place to calculate the inlet velocity.

### **Step 4: Results of the simulation**

There are few outputs to be analysed from the simulation, which are the velocity and pressure streamlines at the cross sections of the thin channel, and the velocity and pressure contours at the inlet, outlet and along the thin channel. From the streamlines and contours, the results will then be compared to the analytical calculations to identify whether the flow is fully developed or vice versa.

### 3.3 Flow chart

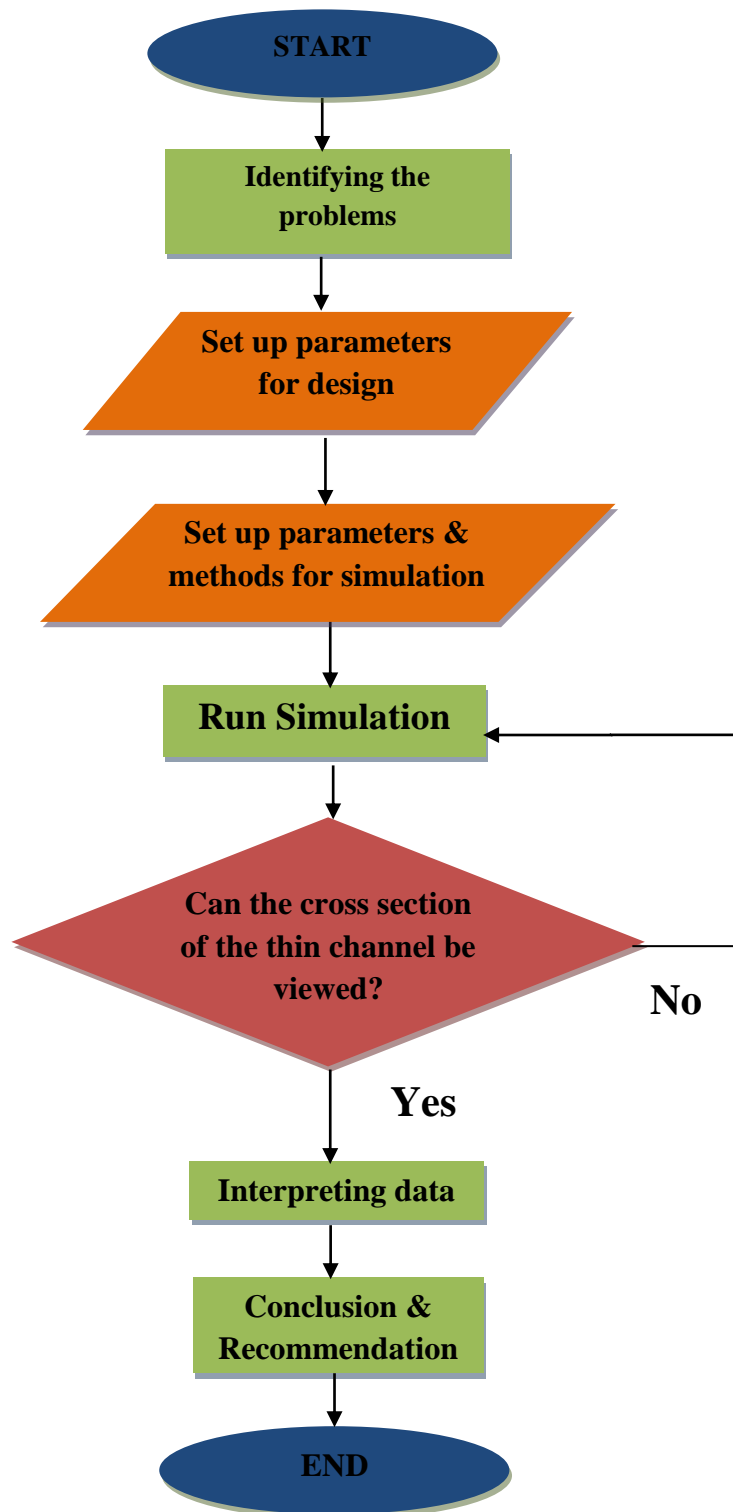

Figure 14: Flow chart for simulation

### 3.4 Project Timeline

Table 1: Gantt chart of Final Year Project I

No	Details / Week	1	2	3	4	5	6	7	8	9	10	11	12	13	14
1.	Selection of Project Topic (Simulation of Flow Characterization in Corrosion Test Rig of Thin Channel Flow Cell (TCFC))														
2.	Preliminary Research Work (Literature review on corrosion)														
3.	Submission of Extended Proposal (Checking by supervisor)														
4.	Proposal Defence (Supervisor and Examiner)														
5.	Project Work Continues (Modelling of TCFC)														
6.	Project Work Continues (Identify the parameters)														
7.	Submission of Interim Draft Report (Discussions with supervisor)														
8.	Submission of Interim Report (End of FYP I)														



Table 2: Gantt chart of Final Year Project II

No	Details / Week	1	2	3	4	5	6	7	8	9	10	11	12	13	14	15
1.	Project Work Continues (Simulating the model)	■	■	■	■	■	■	■	■							
2.	Submission of Progress Report (Checking by supervisor)										■					
3.	Project Work Continues (Simulating the model)									■	■					
4.	Pre- Sedex (Poster Presentation)											■				
5.	Project Work Continues (Compare results)											■	■			
6.	Submission of Draft Final Report (Checking by Supervisor)											■				
7.	Submission of Dissertation (soft bound)												■			
8.	Submission of Technical Paper													■		
9.	Viva														■	
10.	Submission of Dissertation (hard bound)															■

### 3.5 Project Key-Milestone

Aside from compulsory report submission and evaluation of the project, it has 3 main key milestones, which are the modelling of TCFC; identifying the parameters used during simulations and analytical method to compare with the simulation results.

## Chapter 4: Results and Discussion

### 4.1 Modelling fluid in ANSYS Fluent

#### 4.1.1 Geometry of models

In order to determine the flow development in the thin channel, a model as shown in Figure 15 which the fluid flows needs to be constructed. Inlet and outlet need to be seen clearly so that the parameters are easier to be set later. Dimensions are taken from Universiti Teknologi PETRONAS (UTP) Corrosion Centre including its detailed engineering specifications as stated in Table 3 below.

Table 3: Engineering details of Thin Channel Flow Cell (TCFC)

Specifications	Details
Actual flow channel dimensions	805 mm x 64 mm x 3 mm
Maximum flow rates	50 gpm
Maximum speed	750 rpm
Minimum pressure in the system	60 psi

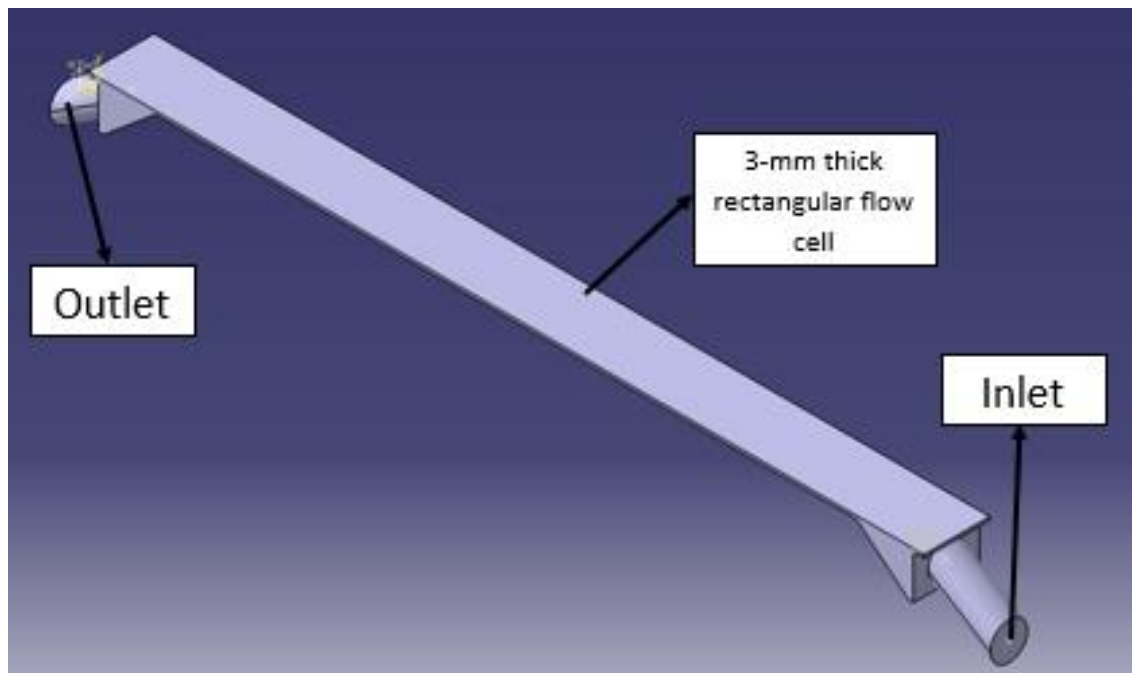

Figure 15: Model for CFD Fluent Simulation

### 4.1.2 Meshing

Meshing will determine the accuracy of the simulation. The smaller the cell, the more number of cells will be produced on the geometry, thus creating a more detailed simulation. Two key factors that need to be considered during meshing are:

1. Aspect ratio
2. Element quality

#### Aspect ratio:

It is defined as the ratio between the longest dimensions to the shortest dimensions of the quadrilateral element in the mesh. It can be a form of judgment on the quality of the mesh whether the mesh contained many errors or not. If the value of the aspect ratio is big, the simulation was said to be less accurate. Based on Figure 12, the aspect ratio obtained is less than 2, which is within the range and this result is considered to be high quality.

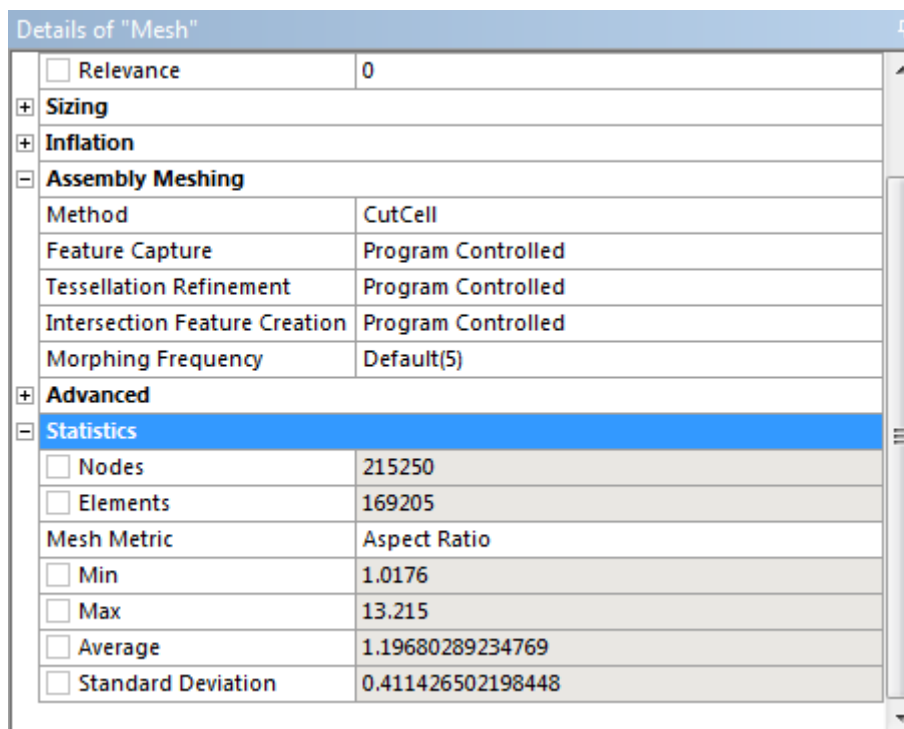

The screenshot shows a software interface window titled "Details of 'Mesh'". It contains a tree view on the left with expandable sections: Relevance, Sizing, Inflation, Assembly Meshing, Advanced, and Statistics. The Statistics section is expanded, showing a table of mesh metrics.

Details of "Mesh"	
<input type="checkbox"/> Relevance	0
⊕ Sizing	
⊕ Inflation	
⊖ Assembly Meshing	
Method	CutCell
Feature Capture	Program Controlled
Tessellation Refinement	Program Controlled
Intersection Feature Creation	Program Controlled
Morphing Frequency	Default(5)
⊕ Advanced	
⊖ Statistics	
<input type="checkbox"/> Nodes	215250
<input type="checkbox"/> Elements	169205
Mesh Metric	Aspect Ratio
<input type="checkbox"/> Min	1.0176
<input type="checkbox"/> Max	13.215
<input type="checkbox"/> Average	1.19680289234769
<input type="checkbox"/> Standard Deviation	0.411426502198448

Figure 16: Aspect ratio

### Element quality:

Element quality can also be a form of judgment on the quality of mesh. Element quality basically determine the quality of the mesh. A higher percentage of element quality will leads to a better accuracy, thus producing a more accurate result.

According to Wang (2013), for a good simulation, element quality should be less than 0.98. Based on the figure below, it is shown that most of the elements in the geometry have reached approximately 97% quality, which shows that the simulation is within the acceptable range.

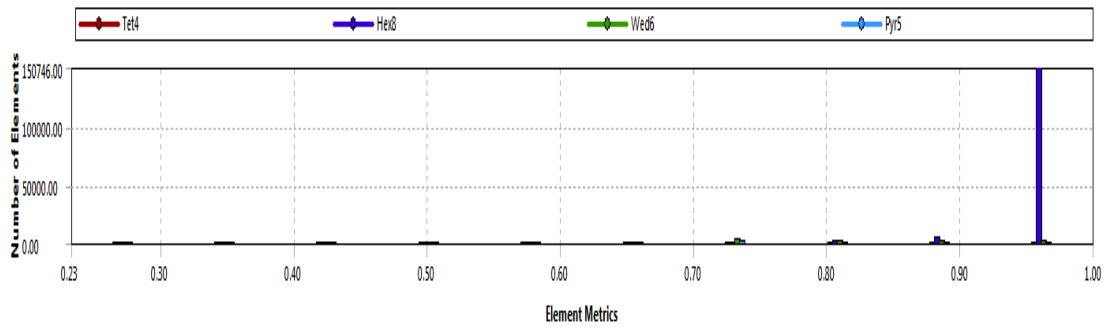

Figure 17: Element quality

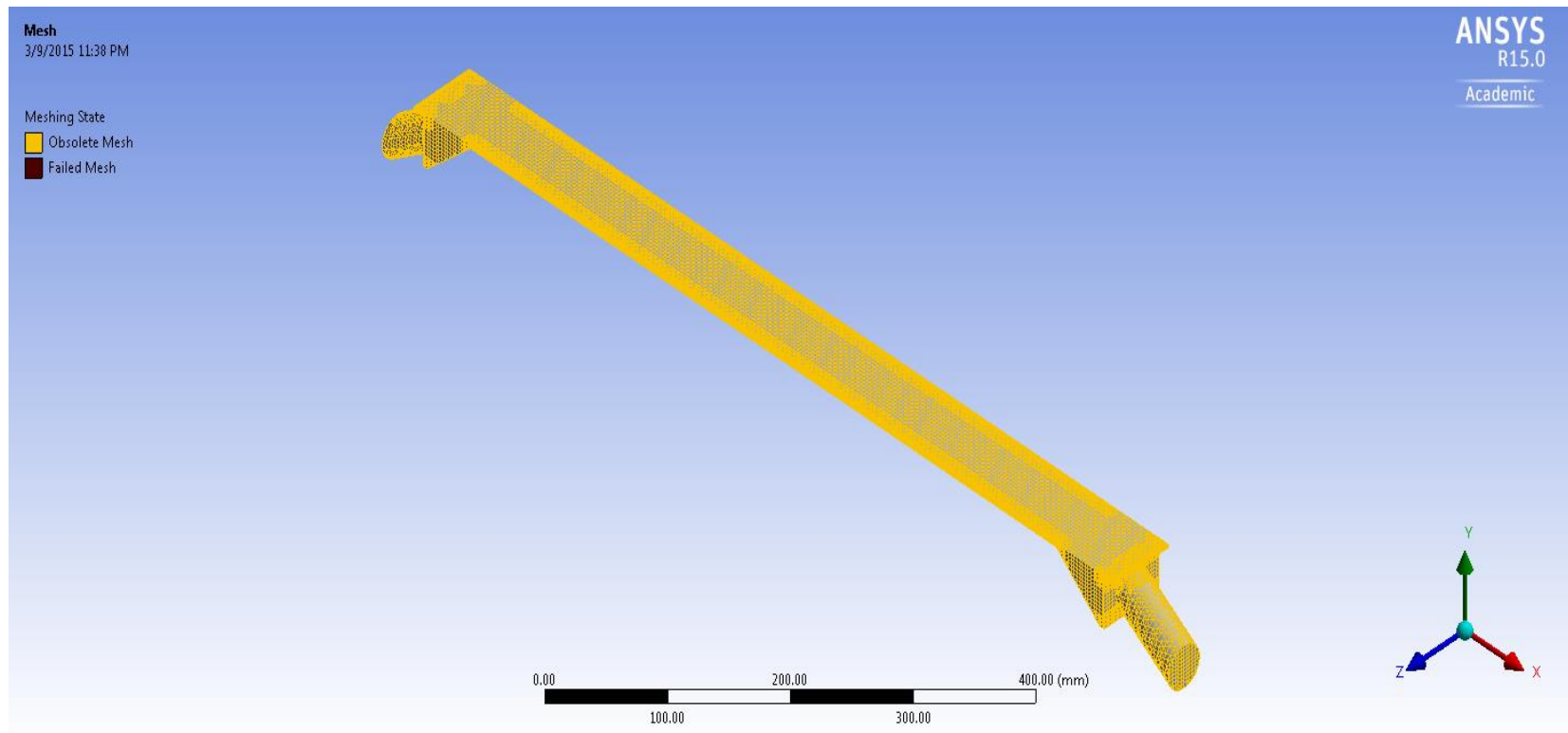

Figure 18: Meshing of the model

## 4.2 Setup for model - Simulation solution method, calculations and assumptions

The fluid type chosen for the simulation is water, which is set to be 998 kg/m<sup>3</sup>. Solution method is the setup for the user to choose to instruct ANSYS on which solution to be used to solve the problem. In this project, the scheme chosen is the most common scheme which is known as “SIMPLE”. This is a suitable scheme for incompressible fluid flow; and for the gradient, “Least Square Cell Based” is used as the simulation which is related to incompressible and single phase flow.

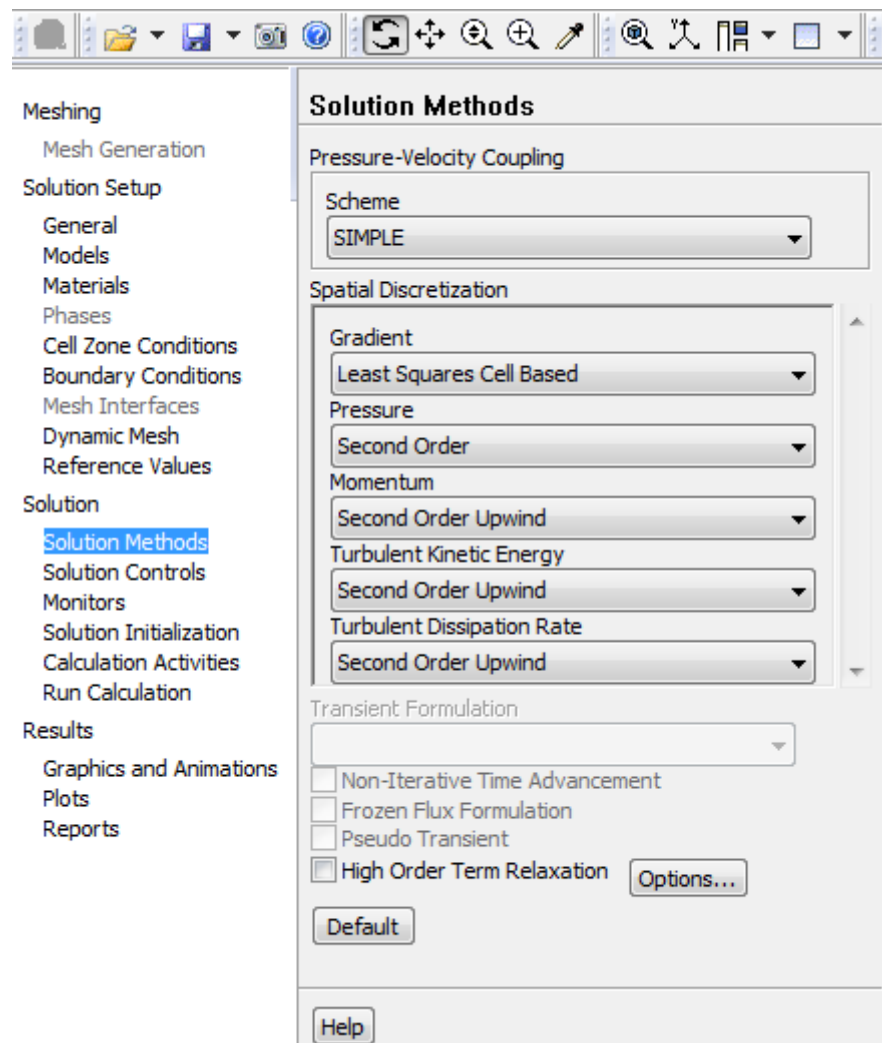

Figure 19: Solution methods used for this simulation

### 4.3 Simulation results

Simulation was conducted to analyse velocity in the TCFC by varying the flow rate as shown in Table 4. The calculated velocities in the TCFC is to be compared with the velocities obtained in the TCFC during simulation. To calculate the velocity in the TCFC, the flow rate in the pipe and TCFC are equal, but the velocity,  $v$  and area,  $A$  in both pipe and TCFC are varied.

*Flow rate in the pipe = flow rate in the TCFC*

$$Q_1 = Q_2$$

$$v_1 A_1 = v_2 A_2 \text{ (Eq. 10)}$$

Table 4: Calculated velocities in pipe and TCFC

Flow rate (gpm)	Calculated velocity in pipe (m/s)	Calculated velocity in TCFC (m/s)
5	0.3	1.65
10	0.6	3.31
15	0.9	4.97
20	1.2	6.62
25	1.5	8.28
30	1.9	9.94
35	2.2	11.59
40	2.5	13.25
45	2.8	14.90
50	3.1	16.56

## Simulation results of velocity in TCFC

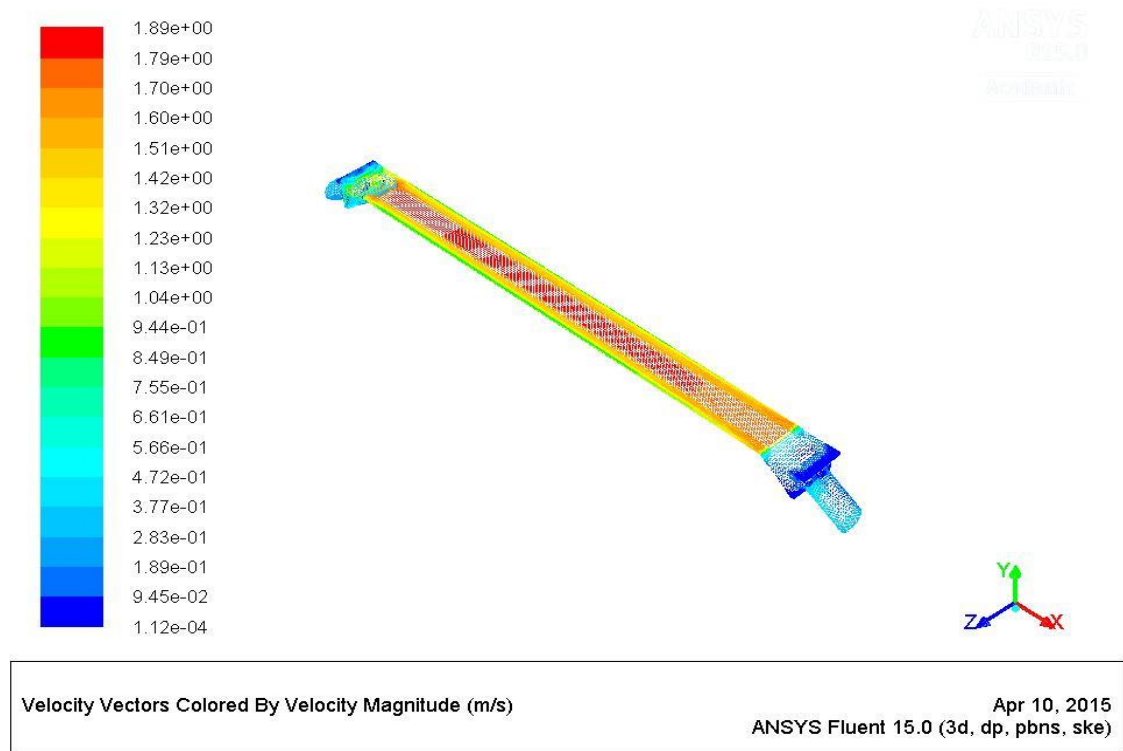

Figure 20: Water velocity in the TCFC at 5 gpm

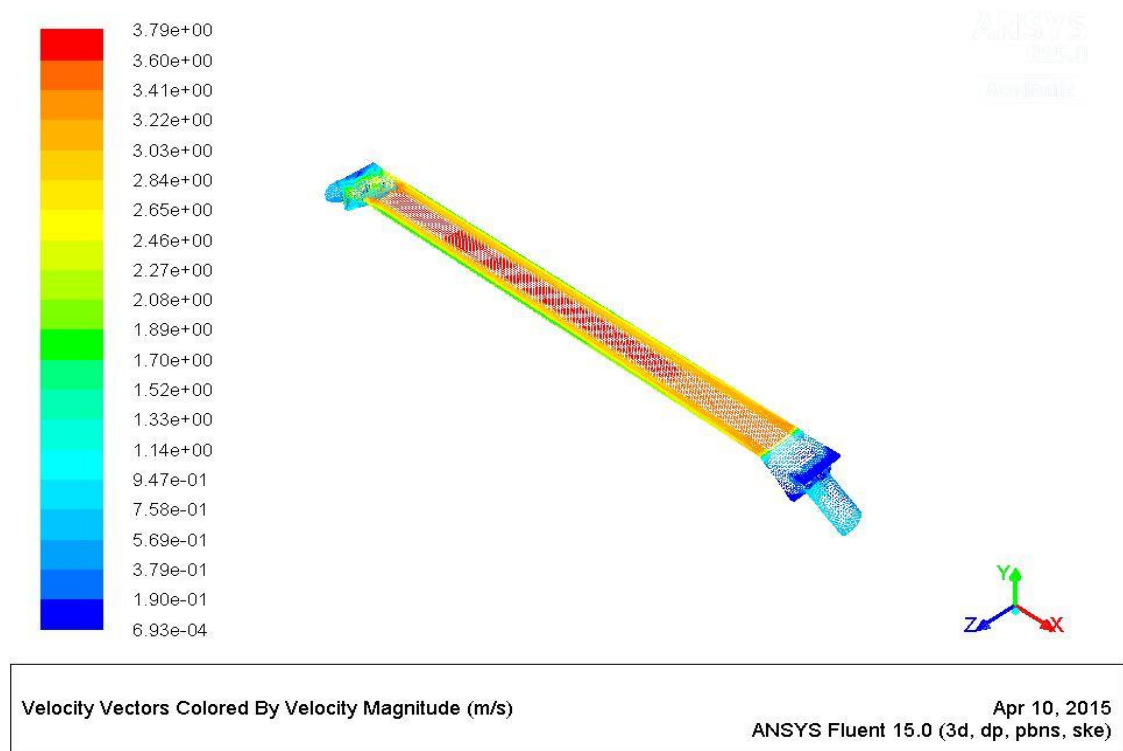

Figure 21: Water velocity in the TCFC at 10 gpm



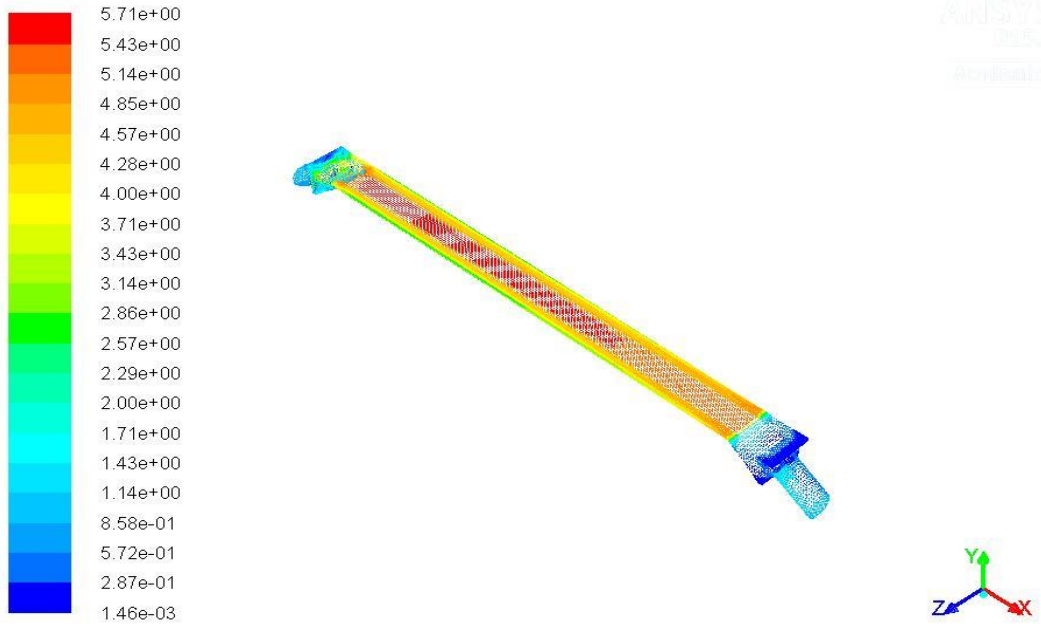

Figure 22: Water velocity in the TCFC at 15 gpm



Figure 23: Water velocity in the TCFC at 20 gpm



Velocity Vectors Colored By Velocity Magnitude (m/s)

Apr 09, 2015  
ANSYS Fluent 15.0 (3d, dp, pbns, ske)

Figure 24: Water velocity in the TCFC at 25 gpm

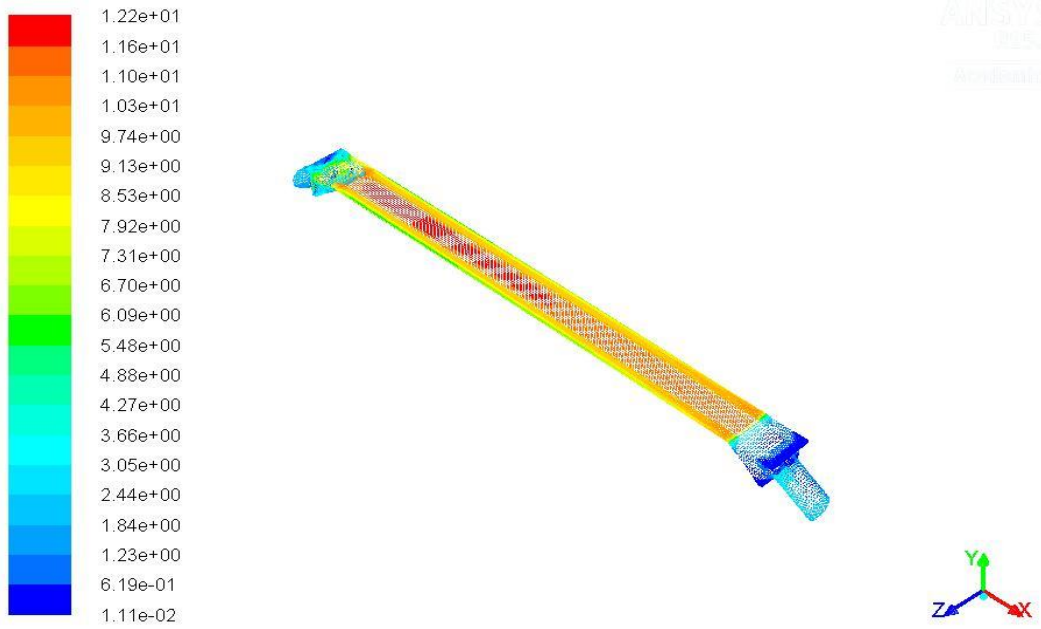

Velocity Vectors Colored By Velocity Magnitude (m/s)

Apr 09, 2015  
ANSYS Fluent 15.0 (3d, dp, pbns, ske)

Figure 25: Water velocity in the TCFC at 30 gpm

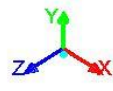
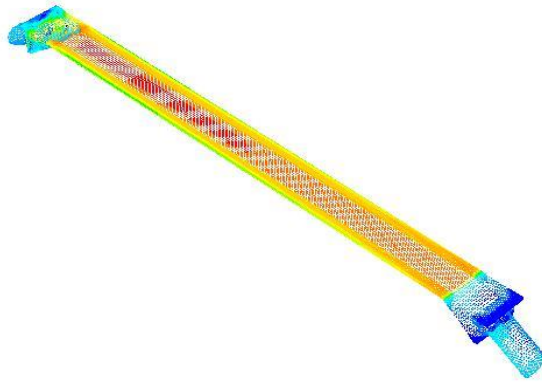
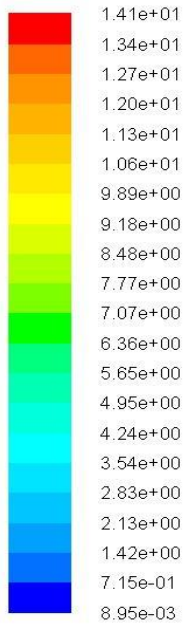

Velocity Vectors Colored By Velocity Magnitude (m/s) Apr 09, 2015  
ANSYS Fluent 15.0 (3d, dp, pbns, ske)

Figure 26: Water velocity in the TCFC at 35 gpm

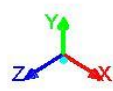
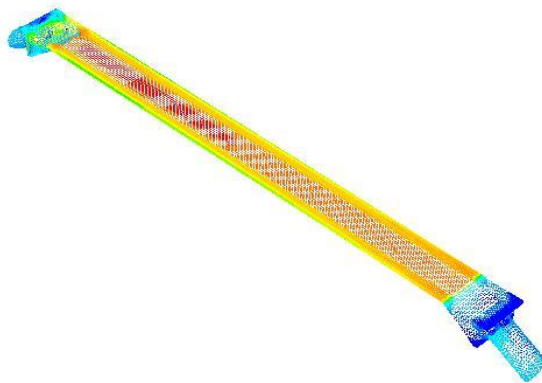
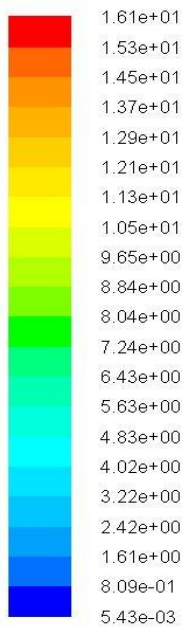

Velocity Vectors Colored By Velocity Magnitude (m/s) Apr 09, 2015  
ANSYS Fluent 15.0 (3d, dp, pbns, ske)

Figure 27: Water velocity in the TCFC at 40 gpm



Figure 28: Water velocity in the TCFC at 45 gpm

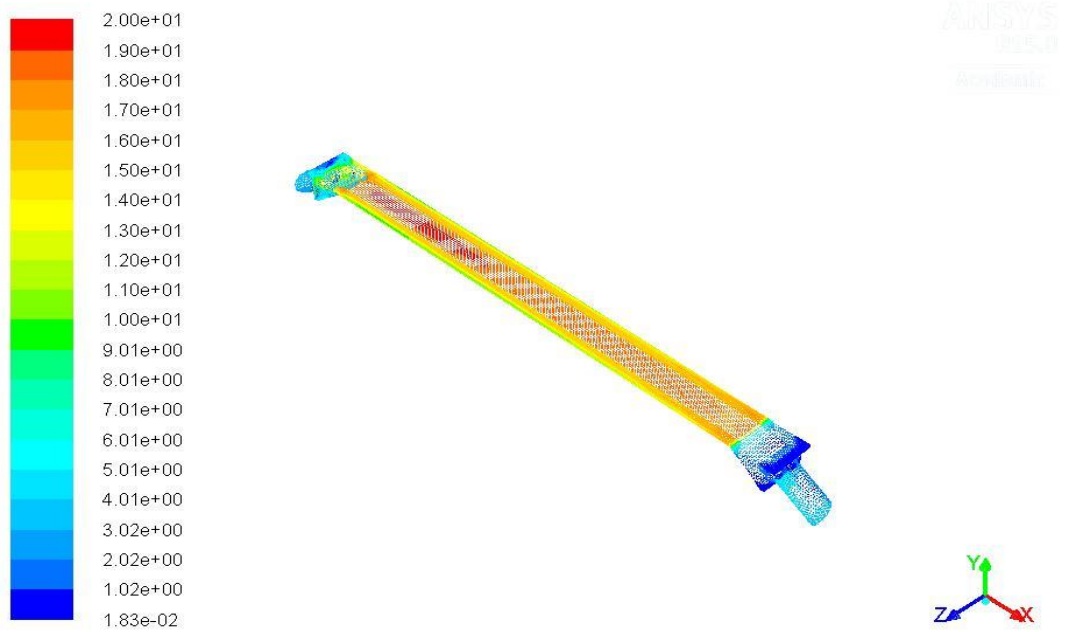

Figure 29: Water velocity in the TCFC at 50 gpm

#### 4.4 Analytical Calculation

The simulation velocity result in TCFC is being compared to the calculated velocity in the TCFC as shown in Table 5. From here, the wall shear stress can be calculated using both calculated and simulation velocity results which is calculated in Table 6. Reynolds number needs to be calculated first, so that wall shear stress at particular velocity can be calculated. Reynolds number indicates the ratio between inertial force and viscous force which is stated at equation 6. Reynolds number is also used to indicate whether the flow regime is laminar, turbulent, or transitional. The formulas used to calculate the wall shear stress are provided at equation 6, 7 and 8.

Table 5: Velocities obtained during simulation

Flow rate (gpm)	Velocity in pipe (m/s)	Calculated velocity in TCFC (m/s)	Velocity obtained during simulation (m/s)
5	0.3	1.65	1.89
10	0.6	3.31	3.79
15	0.9	4.97	5.71
20	1.2	6.62	7.64
25	1.5	8.28	9.58
30	1.9	9.94	12.20
35	2.2	11.59	14.10
40	2.5	13.25	16.10
45	2.8	14.90	18.00
50	3.1	16.56	20.00

Wall shear stress is calculated by following few steps:

- Step 1 – calculate Reynolds number using calculated velocity in TCFC (equation 6)
- Step 2 – calculate friction factor using previous Reynolds number (equation 5)
- Step 3 – calculate wall shear stress using calculated velocity in TCFC (equation 7)
- Step 4 – repeat step 1, 2 and 3 for velocity obtained during simulation

Table 6: Wall shear stress for both calculated velocity and velocity obtained during simulation in TCFC

Reynolds number in TCFC using calculated velocity	Reynolds number in TCFC using velocity obtained during simulation	Calculated friction factor	Simulation velocity friction factor	Wall shear stress using calculated velocity in TCFC (Pa)	Wall shear stress using simulation velocity in TCFC (Pa)
5822.34	6654.93	0.0083570	0.0080823	11.42	14.44
11663.15	13345.07	0.0070246	0.0067919	38.54	48.78
17485.49	20105.63	0.0063482	0.0061305	78.27	99.94
23326.31	26901.41	0.0059069	0.0057001	129.62	166.35
29148.65	33732.39	0.0055869	0.0053866	191.43	247.18
34989.46	42957.75	0.0053375	0.0050706	263.52	377.36
40811.80	49647.89	0.0051360	0.0048904	344.99	486.13
46652.62	56690.14	0.0049671	0.0047309	435.98	613.15
52474.95	63380.28	0.0048232	0.0046008	535.61	745.33
58315.77	70422.54	0.0046976	0.0044812	644.25	896.24

## 4.5 Discussions

### 4.5.1 Graph and percentage error

The velocities obtained during simulation in the TCFC differ with the calculated velocity in the TCFC. This simultaneously affects the wall shear stress obtained to analyse the corrosion rate of certain materials.

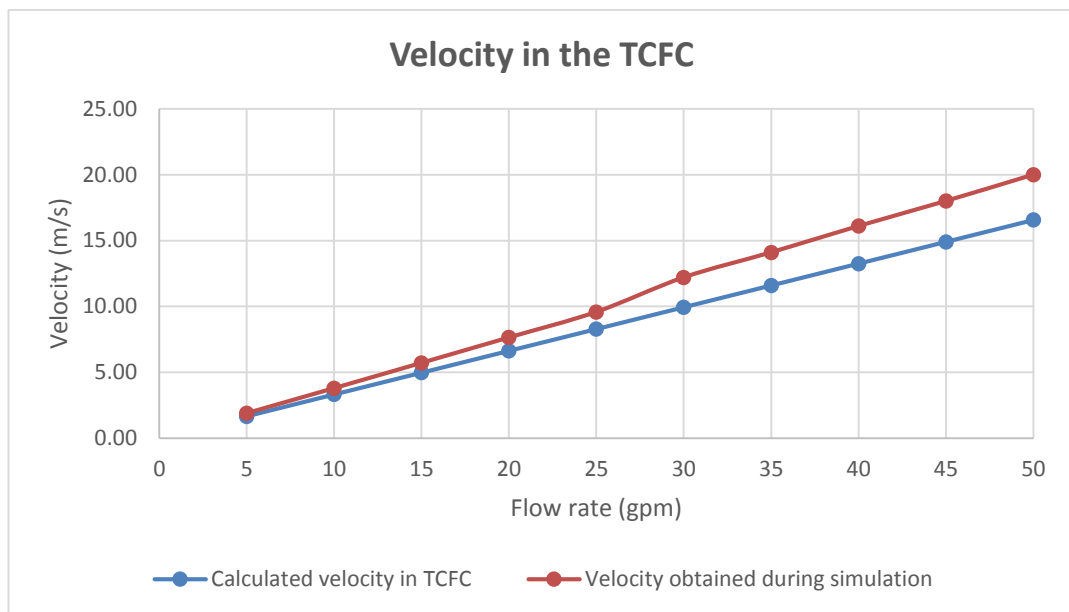

Figure 30: Velocity in the TCFC graph

In Figure 30, it is shown that the velocity obtained during simulation is higher than the calculated by a range of percentage error. By using equation

$$\text{Percentage Error} = \left| \frac{\text{Calculated} - \text{Simulation}}{\text{Calculated}} \right| \times 100 \% \text{ (Eq. 11)}$$

The percentage error calculated for these differences are still within the acceptable range, which are below 20% as stated in the Table 7.

Table 7: Percentage error of velocity

Flow rate (gpm)	Percentage error of velocity (%)
5	14.30
10	14.42
15	14.98
20	15.33
25	15.73
30	22.77
35	21.65
40	21.52
45	20.78
50	20.76

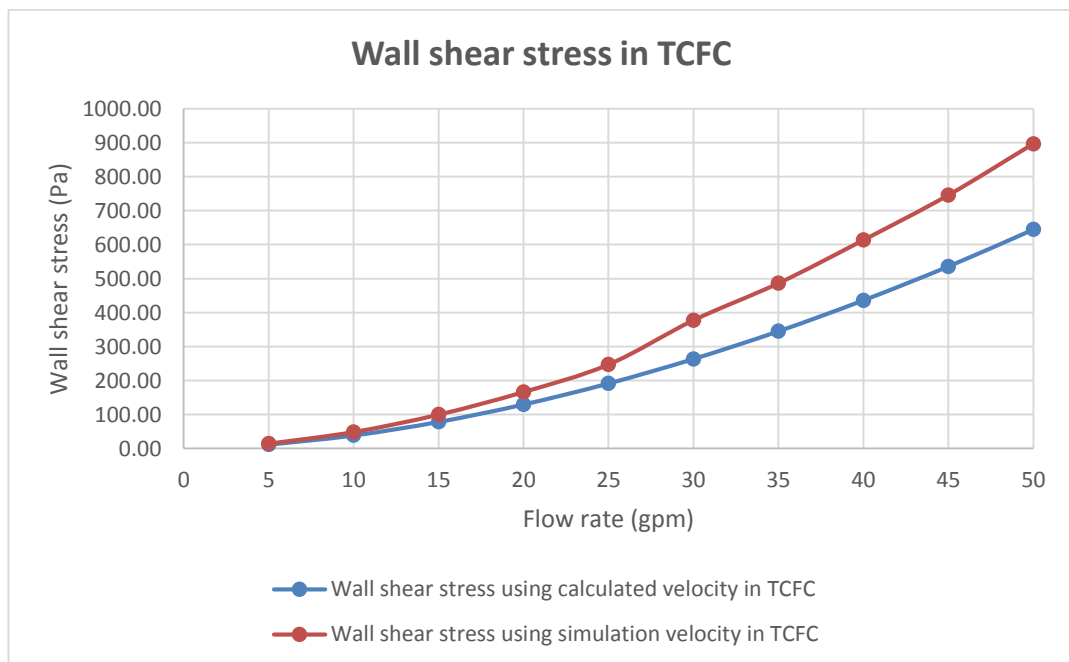

Figure 31: Wall shear stress in TCFC graph



Unlike wall shear stress, the percentage error calculated for each flow rates exceeded the acceptable range. This is shown in Table 8.

Table 8: Percentage error of velocity

Flow rate (gpm)	Percentage error of wall shear stress (%)
5	26.35
10	26.59
15	27.68
20	28.34
25	29.12
30	43.20
35	40.91
40	40.64
45	39.16
50	39.11

#### 4.5.2 Uniformity of velocity on corrosion coupons

A uniform velocity profile across all three corrosion coupons are required to get an acceptable result on wall shear stress acting on them. The simulation results are analysed to identify the uniformity of velocity profile across the coupons. Figure 32 shows the arrangement of corrosion coupons on the surface of TCFC. In Figure 20 until Figure 29, an analysis is carried out to identify the difference in velocity profile across each of the corrosion coupons by differentiating the velocity contours. The difference in velocity across each coupons are summarized in Table 9.

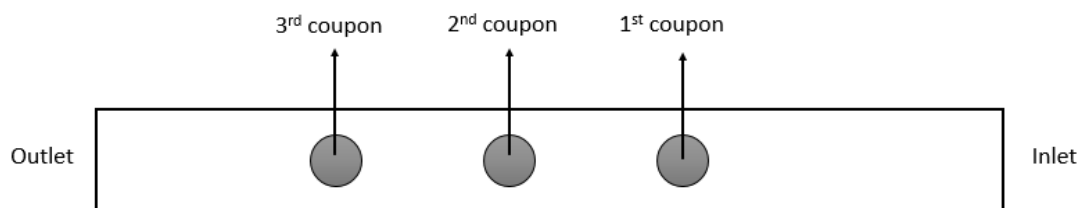

Figure 32: Arrangement of corrosion coupons in TCFC

Table 9: Velocity difference across each corrosion coupon

Flow rate (gpm)	Velocity (m/s)		
	1 <sup>st</sup> coupon	2 <sup>nd</sup> coupon	3 <sup>rd</sup> coupon
5	1.89	1.89	1.89
10	3.79	3.79	3.79
15	5.71	5.71	5.71
20	7.26	7.64	7.64
25	9.10	9.58	9.58
30	11.60	11.60	12.20
35	13.40	13.40	14.10
40	15.30	15.30	16.10
45	17.10	17.10	18.00
50	19.00	19.00	20.00

From Table 9, it is shown that the velocity profile across all the coupons is only uniform at the flow rates of 5 gpm to 15 gpm. This is followed by the flow rates at 20 gpm to 25 gpm, velocity profile across first coupon is not similar to the second and third coupon. Similarly, at flow rates of 35 gpm to 50 gpm, the velocity profile changes as it is only uniform across the first and second coupon. As a summary of velocity profile, when the flow rate increases, the velocity profiles across all the corrosion coupons are not uniform.

## Chapter 5: Conclusions and Recommendation

### 5.1 Conclusions

To conclude, the result obtained during simulation including modelling of the geometry, meshing and setting up the solutions are all in the acceptable range. As what we have observed, there are two parameters used to identify whether the meshing quality is in the acceptable range or not, which are aspect ratio and element quality. Both parameters obtained reliable results which lead to a high quality simulation result.

The velocities obtained in the Thin Channel Flow Cell (TCFC) during simulation are compared to the calculated velocities in the TCFC. It is identified that these two velocities varied but still in the acceptable range, which is below 20%. Unlike the wall shear stress in the TCFC for both calculated and simulation, the results varied quite a lot which exceeded the acceptable range. This maybe because of the assumptions made earlier where the pipe and TCFC are assumed to be connected directly without any transition. The calculations for this may give a lot of effects to the calculation of velocity. Apart from that, the uniformity of velocity profile across all the corrosion coupons is proven to be non-uniform as the flow rate increases.

In a nutshell, the velocity in the TCFC during simulation and calculation are different but still within the acceptable range. Type of flow develops at different flow rates in TCFC are concluded to be turbulent as stated in Table 4. As the flow rate increases, the wall shear stress developed across all the corrosion coupons also increases.

## 5.2 Recommendation

As per discussed in section 4.5, it is shown that the percentage error of velocity is within the acceptable range, unlike the percentage error of wall shear stress which exceeded the acceptable range. It is recommended that the analytical calculation to calculate the velocity in TCFC needs to be improved. It is previously assumed that the flow rate in the pipe and in the TCFC is equal and calculated directly like in Figure 22, which is proven to be inaccurate.

Supposedly, in order to calculate the flow rate in the pipe and TCFC, the transition in between the TCFC and pipe need to be considered. Here, the velocity may vary because of the transition. Apart from that, an experiment needs to be conducted to compare these simulation results to the experimental results.

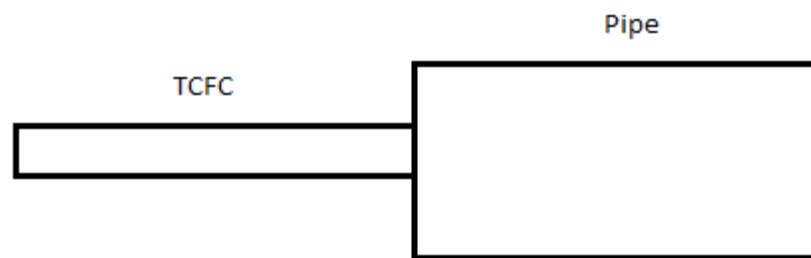

Figure 33: Current assumption

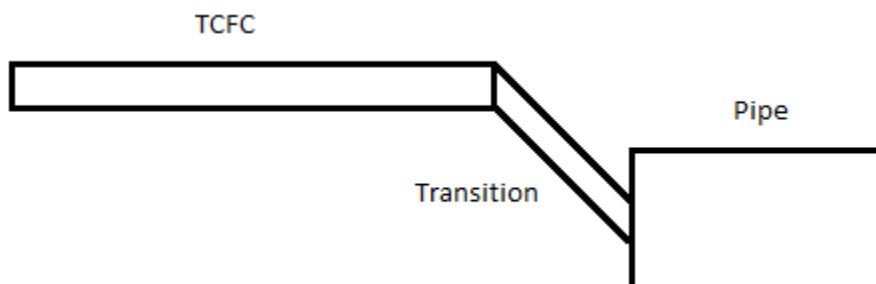

Figure 34: Recommended assumption

## References

- Akeer, E., Brown, B., & Nestic, S. (2013). The Influence of Mild Steel Metallurgy on the Initiation of Localized carbon dioxide corrosion in Flowing Conditions. *Corrosion NACE* .
- Chen, Y., Jepson, W. P., & Chen, H. J. (1999, January 1). Effects of Multiphase Flow on Corrosion Inhibitor. NACE International.
- Chen, Y., Zhang, L., Qin, H., Xu, L., & Lu, M. (2011, January 1). Effects Of Temperature On CO2 Top Of Line Corrosion Of Pipeline Steel. NACE International.
- Computer Applications in Hydraulic Engineering. (2002). *Haestead Methods*.
- Farelas, F., Galicia, M., & Castaneda, H. (2009). Evolution of dissolution processes at the interface of carbon steel corroding in a CO2 environment studied by EIS. *Corrosion Science*, 509 - 517.
- G.A. Zhang, Y. C. (2010). Electrochemical characterization and computational fluid dynamics simulation. *Corrosion Science*, 2716-2724.
- Homicz, G. (2004). Computational Fluid Dynamic Simulations of Pipe Elbow Flow. California: Sandia National Laboratories.
- Li, C., Xiong, Y., Pacheco, J. L., Cao, F., Desai, S. K., & Ling, S. (2014, May 13). Effect of Wall Shear Stress on Sour Corrosion of Carbon Steel. NACE International.
- Nor, A. M., Suhor, M. F., Mohamed, M. F., Singer, M., & Nestic, S. (2012, January 1). Corrosion Of Carbon Steel In High CO2 Containing Environments - The Effect Of High Flow Rate. NACE International.
- Peng DJ., V. S. (2013). CFD wall shear stress benchmark in stratified-to-annular transitional flow regime. *Flow Assurance*.
- Popoola et al. (2013). Corrosion problems during oil and gas production and its mitigation. *International Journal of Industrial Chemistry*
- Sánchez, A. N., Reyes, D., Sánchez, M., Millano, V., & de Rincón, O. T. (2013, March 17). Performance of Corrosion Inhibitors under Different Flow Regimes. NACE International.
- Schmitt, G., Wade, J., Wilmes, S., Feser, R., Sagebiel, B., Kapsalis, C., & Macziek, M. (2011, January 1). Critical Wall Shear Stresses Of Cuni Alloys Revisited. NACE International.
- Study of Mass Transport Limited Corrosion with Pine Rotating Cylinder Electrodes. (2013). *PINE Research Instrumentation*.

- Tanupabrungrsun, T., Brown, B., & Nestic, S. (2013, March 17). Effect of pH on CO<sub>2</sub> Corrosion of Mild Steel at Elevated Temperatures. NACE International.
- Wang, L. (2013). CFD simulation of void flow in ECCS. Masters Theses.
- Xu, L., Xie, Y., Lu, M., Zhang, L., & Chang, W. (2012, January 1). Effect of Temperature on Wet CO<sub>2</sub> Corrosion Of 3%Cr Pipeline Steel. NAC
- Yang, Y., Brown, B., & Gennaro, M. E. (2010). Mechanical strength and removal of a protective iron carbonate layer formed on mild steel in CO<sub>2</sub> corrosion. *Corrosion NACE* .
- Zeng, L., Zhang, G. A., & Huang, H. L. (2013). A study of flow accelerated corrosion at elbow of carbon steel pipeline. *Corrosion Science*, 334-341