

**Natural Convection Heat Transfer and Fluid Flow in Enclosures  
with Varying Aspect Ratios (CFD)**

by

Wong Yean Sang

16097

Dissertation submitted in partial fulfilment of

the requirements for the

Degree of Study (Hons)

(Chemical)

FYP II JANUARY 2015

Universiti Teknologi PETRONAS

Bandar Seri Iskandar

31750 Tronoh

Perak Darul Ridzuan

CERTIFICATION OF APPROVAL

**Natural Convection Heat Transfer and Fluid Flow in Enclosures  
with Varying Aspect Ratios (CFD)**

by

WONG YEAN SANG

A project dissertation submitted to the

Chemical Engineering Program

Universiti Teknologi PETRONAS

In partial fulfilment of the requirement for the

BACHELOR OF ENGINEERING (Hons)

CHEMICAL ENGINEERING

Approved by,

---

(Dr. Rajashekhar Pendyala)

UNIVERSITI TEKNOLOGI PETRONAS

TRONOH, PERAK

JANUARY 2015

## CERTIFICATION OF ORIGINALITY

This is to certify that I am responsible for the work submitted in this project, that the original work is my own except as specified in the references and acknowledgements, and that the original work contained herein have not been undertaken or done by unspecified sources or persons.

---

WONG YEAN SANG

## **ABSTRACT**

Buoyancy driven natural convection in enclosures has wide range of engineering applications in heat transfer processes. The study of fluid flow and heat transfer characteristics in enclosures has significant importance towards thermal management and optimal design of the system. Limited studies are available on the numerical simulation of 3-Dimensional enclosures with varying aspect ratios (H/L). Heat transfer characteristics has been investigated in 3D enclosure with hot and cold surface by Computational Fluid Dynamics (CFD) simulating at low ( $0.125 \leq AR \leq 50$ ) and high ( $51 \leq AR \leq 150$ ) aspect ratios. CFD simulations have been performed with different fluids (fluid 1, fluid 2 and fluid 3) at temperature range of  $20K \leq \Delta T \leq 100K$  and Prandtl number range of  $0.01 \leq Pr \leq 4200$ . The predicted profiles for velocities and heat transfer coefficients are presented. Correlations for Nusselt number based on predicted findings have been developed to study heat transfer characteristics.

## **ACKNOWLEDGEMENT**

The author would like to take this opportunity to convey greatest gratitude to Chemical Engineering Department of Universiti Teknologi PETRONAS in providing the Blok 5 Simulation Lab as the venue for my project simulation for two semesters. First of all, sincerest gratitude extended to Dr. Rajashekhar Pendyala, the FYP supervisor for his explanations and instructions given in this project entitled “Natural Convection Heat Transfer and Fluid Flow in Enclosures with Varying Aspect Ratios (CFD)”. His attentive supervision and guidance given on ANSYS Fluent 15.0 is much appreciated. Furthermore, thanks to the assistance of PHD student, Mr. Suhaib Umer Ilyas in providing additional information for the project. Next, special thanks to the advice and support of FYP coordinator and FYP examiner, this thesis has turned out to be a successful and meaningful paper for fundamental research understanding of natural convection behavior in rectangular enclosures varying aspect ratio.

Thank you.

## TABLE OF CONTENT

CERTIFICATION OF APPROVAL .....	1
CERTIFICATION OF ORIGINALITY .....	2
ABSTRACT.....	3
ACKNOWLEDGEMENT .....	4
LIST OF FIGURES .....	7
LIST OF TABLES .....	9
ABBREVIATIONS AND NOMENCLATURES .....	10
INTRODUCTION .....	11
1.1 Background .....	11
1.1.1 Theory.....	11
1.1.2 ANSYS FLUENT (CFD) .....	12
1.2 Problem Statement .....	13
1.3 Objectives and Scope of Study.....	14
1.3.1 Objectives .....	14
1.3.2 Scope of Study.....	14
LITERATURE REVIEW .....	16
2.1 Governing Equation .....	16
2.2 Previous Work.....	18
METHODOLOGY .....	22
3.1 Critical Analysis of Literature.....	23
3.2 Data Gathering .....	23
3.3 Geometry Construction .....	24
3.4 Geometry Meshing.....	25
3.5 Setup of Model.....	26

3.5.1 ANSYS FLUENT Launcher.....	26
3.5.2 General Setup.....	27
3.5.3 Model.....	28
3.5.4 Material.....	28
3.5.5 Boundary Condition .....	30
3.5.6 Operating Condition .....	31
3.5.7 Solution Method .....	32
3.5.8 Residual Monitors.....	33
3.5.9 Solution Initialization .....	33
3.6 Post-processing.....	34
<b>RESULTS AND DISCUSSION .....</b>	<b>37</b>
4.1 Effect of Aspect Ratio and Fluid Properties on Heat Transfer Performance ...	37
4.2 Effect of Aspect Ratio and Fluid Properties on Fluid Flow .....	40
4.3 Effect of temperature difference and aspect ratio on Nusselt number .....	42
4.4 Effect of aspect ratio on flow patterns for different fluid.....	46
4.5 Development of Correlations for Nusselt Number .....	49
<b>CONCLUSION AND RECOMMENDATION.....</b>	<b>51</b>
5.1 Conclusion.....	51
5.2 Recommendation.....	51
<b>REFERENCES .....</b>	<b>53</b>

## LIST OF FIGURES

Figure 1: Natural Convection in Enclosure.....	11
Figure 2: Velocity Profile shown in ANSYS Fluent .....	13
Figure 3: Geometry Layout.....	15
Figure 4: Vertical Rectangular Enclosure .....	17
Figure 5: Flow Patterns for Different Aspect Ratios .....	21
Figure 6: Research Methodology Flowchart.....	22
Figure 7: Geometry Construction .....	25
Figure 8: Geometry Meshing .....	26
Figure 9: Setting in ANSYS FLUENT Launcher .....	27
Figure 10: General Setup .....	27
Figure 11: Model turned on .....	28
Figure 12: Properties of Fluids Inserted in Fluent .....	29
Figure 13: Insulation Material.....	30
Figure 14: Hot wall boundary condition .....	30
Figure 15: Insulated wall boundary condition .....	31
Figure 16: Operating Conditions.....	31
Figure 17: Setup of Solution Method.....	32
Figure 18: Residuals Monitor .....	33
Figure 19: Solution Initialization .....	33
Figure 20: Temperature distribution in enclosure for $\Delta T = 60$ K .....	38
Figure 21: Variation of Static Temperature with Aspect Ratio .....	39
Figure 22: Variation of Specific Heat Capacity with Aspect Ratio.....	39
Figure 23: Velocity vector for fluid 1 at temperature gradient of 100K.....	41
Figure 24: Variation of Viscosity with Aspect Ratio.....	41
Figure 25: Variation of Nusselt Number with Aspect Ratio for Fluid 1 .....	43
Figure 26: Variation of Nusselt Number with Aspect Ratio for Fluid 2 .....	43
Figure 27: Variation of Nusselt Number with Aspect Ratio for Fluid 3 .....	44
Figure 28: Temperature distribution in enclosure for $\Delta T = 100$ K.....	45
Figure 29: Velocity distribution in enclosure for $\Delta T = 100$ K.....	47
Figure 30: Variation of Heat Transfer Coefficient with Aspect Ratio for Fluid 1.....	47



Figure 31: Variation of Heat Transfer Coefficient with Aspect Ratio for Fluid 2.....	48
Figure 32: Variation of Heat Transfer Coefficient with Aspect Ratio for Fluid 3.....	48
Figure 33: Parity plot for predicted Nusselt number by correlation of fluid 1 .....	49
Figure 34: Parity plot for predicted Nusselt number by correlation of fluid 2 .....	50
Figure 35: Parity plot for predicted Nusselt number by correlation of fluid 3 .....	50

## **LIST OF TABLES**

Table 1: Geometry for Enclosures .....	23
Table 2: Properties of Fluids.....	24
Table 3: Gantt Chart.....	35
Table 4: Key Milestone.....	36

## ABBREVIATIONS AND NOMENCLATURES

AR	Aspect Ratio (-)
$C_p$	Specific Heat Capacity (J/kg K)
g	Gravitational Acceleration ( $m/s^2$ )
Gr	Grashof Number (-)
h	Heat Transfer Coefficient ( $W/m^2 K$ )
H	Height (m)
k	Thermal Conductivity (W/m K)
L	Length (m)
Nu	Nusselt Number (-)
Pr	Prandtl Number (-)
Ra	Rayleigh Number (-)
W	Width (m)
$\mu$	Dynamic Viscosity (kg/ms)
$\Delta T$	Temperature Difference / Temperature Gradient (K)
$\beta$	Thermal Expansion Coefficient (1/K)
$\rho$	Density ( $kg/m^3$ )
$\nu$	Kinematic Viscosity ( $m^2/s$ )
$\alpha$	Thermal Diffusivity ( $m^2/s^2$ )

# CHAPTER 1

## INTRODUCTION

### 1.1 Background

#### 1.1.1 Theory

Heat transfer between two bodies occurred when there is a temperature difference between the contacted parties. Temperature is the main driving force for heat transfer. Heat transfer can take place by means of convection, conduction and radiation. In convection, heat is transfer by fluid motion. Conduction, on the other hand, is a heat transfer that spread through with the collision of atoms with the neighbouring atoms. Whereas, radiation is the transmission of energy in the form of wave. In this project, natural convection heat transfer and fluid flow in enclosures with varying aspect ratios has been numerically studied. Convection heat transfer can be further categorised into natural and forced. In natural convection, fluid move by means of buoyant force. Fluid with higher temperature will have lower density, whilst colder fluid is heavier and will have higher density. As a result, hot fluid with lower density will rise (Figure 1). This movement is known as natural convection current.

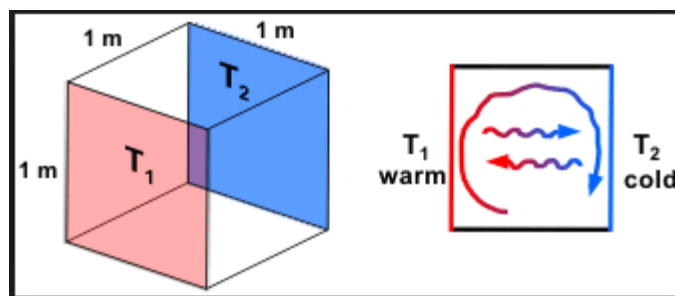

Figure 1: Natural Convection in Enclosure

Due to no external forces applied, velocity and heat transfer coefficient of the fluid associated with natural convection is comparatively lower in forced convection. Furthermore, geometry of cavities causes high impact on the heat transfer and flow of fluid. Geometry with different length, height and width will have different aspect ratios. There are two different types of aspect ratio commonly known as horizontal aspect ratio and vertical aspect ratio. Horizontal aspect ratio is the ratio of width to length

(W/L) of an enclosure, whereas, vertical aspect ratio of an enclosure is defined as the ratio of height to length (H/L). In this project, geometry of eighteen enclosures with different vertical aspect ratios are constructed. Heat transfer and fluid flow over the eighteen cavities are studied and analysed by considering Prandtl number (Pr), Nusselt number (Nu), Rayleigh number (Ra) and Grashof number (Gr). Equations below defined the characteristics mentioned.

$$Pr = \frac{c_p \mu}{k} \quad (1)$$

$$Nu = \frac{hL}{k} \quad (2)$$

$$Ra = \frac{g\beta\Delta TL^3}{\nu\alpha} \quad (3)$$

$$Gr = \frac{g\beta\rho^2 L^3}{\mu^2} \quad (4)$$

Prandtl number is a dimensionless parameter to define characteristic of a fluid. Different fluid at different temperature will have different Prandtl number. In order to thoroughly study the heat transfer of fluid in enclosure, three fluids with different Prandtl number are selected and studied. In addition, for natural convection heat transfer in rectangular enclosure, Nusselt number is highly dominated by Rayleigh number and aspect ratio. Nusselt number is a dimensionless parameter to determine the type of heat transfer occurring in enclosure. A high value of Nusselt number indicates convective heat transfer. Rayleigh number is a dimensionless parameter that determine the type of primarily heat transfer (convective or conductive) in fluid. Rayleigh number is dependent on Grashof number, another dimensionless parameter which approximates the ratio of buoyancy to viscous force acting on fluid. In this project, the relationship between Nusselt number, Prandtl number, Rayleigh number and aspect ratio are studied and analysed in ANSYS FLUENT 15.0 based on the behaviour of fluid flow in enclosures. Correlations for Nusselt number will be developed based on the predicted results from CFD simulations. The effect of temperature difference ( $\Delta T$ ) between hot and cold wall of enclosures on convective heat transfer will be studied as well.

### 1.1.2 ANSYS FLUENT (CFD)

Fluid flow are governed by partial differential equations which represent conservation laws for the mass, momentum, and energy. Computational Fluid Dynamics (CFD) is

the art of replacing such partial differential equation systems by a set of algebraic equations which can be solved using digital computers. CFD is used in all stages of the engineering process:

- Conceptual studies of new designs
- Detailed product development
- Optimization
- Troubleshooting
- Redesign

Mathematical modelling, numerical methods and software tools application are the three CFD methods that able to provide qualitative prediction on fluid flow. ANSYS Fluent is a simulation tool that solve CFD problems based on the finite volume method in which the domain is discretized into a finite set of control volumes. General conservation equations for mass, momentum and energy are solved on the pre-defined control volumes. Discretization of model in ANSYS Fluent are done through meshing in which desired mesh size can be defined. Figure 2 represents the velocity profile of one of the geometry shown in ANSYS Fluent 15.0.

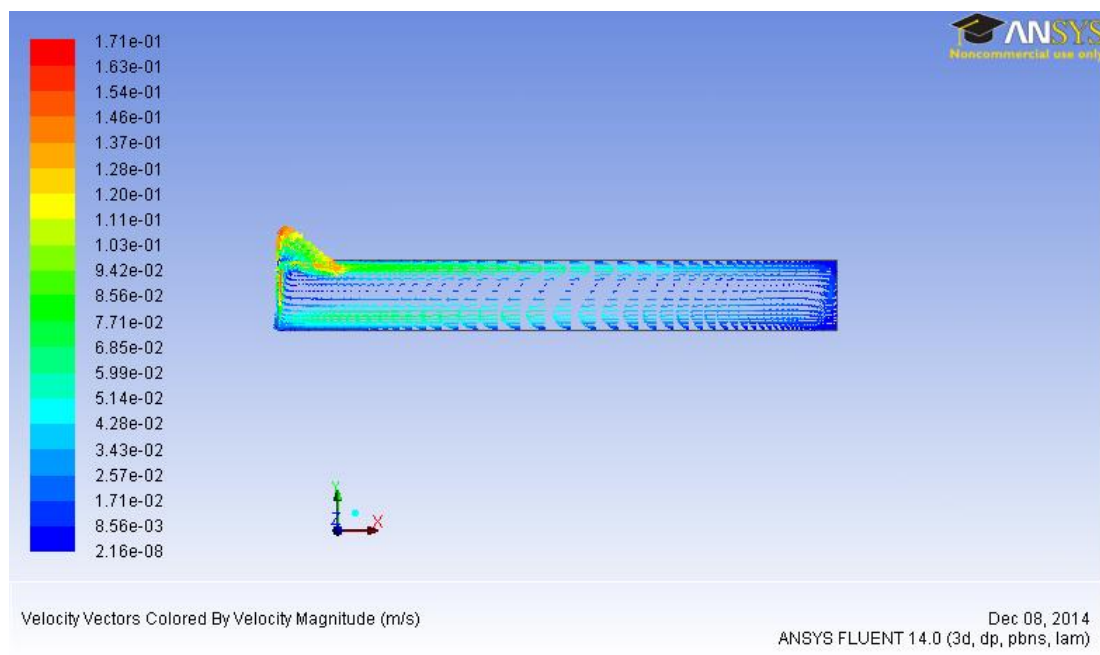

Figure 2: Velocity Profile shown in ANSYS Fluent

## 1.2 Problem Statement

Natural convection heat transfer and fluid flow in enclosures are getting more attention from the industry due to wide variety of engineering applications involving energy conversion, cooling system for electronic devices, non-Newtonian chemical processes,

solar energy collector and double pane windows. Innovative design for these products are very important as an optimum design able to minimize heat loss, minimize condensation of fluid inside the cavity and improve the heat transfer. Using the energy efficiently is able reduce energy consumption and save more energy which will brings a huge advantage to society and environment as saving energy is one of the global concern lately. Research on heat transfer and fluid flow in enclosures is very useful in economical aspect and environmental aspect.

In the past decade, various research on this topic have been done through numerical simulations and experimental methods. However, limited knowledge is available on 3D model simulations using ANSYS Fluent. So, it would be of great significant if detailed study carried out. 3D model is able to predict and illustrate heat transfer thoroughly due to edge effect of the enclosure. The results will be more reliable and accurate compared to 2D model simulation. A more innovative and optimum design could also be obtained by referring to the results of 3D model simulation. Therefore, this project focuses on simulation of natural convection heat transfer and fluid flow in 3D enclosure with varying aspect ratios. Furthermore, each of the enclosures are studied using different fluids by varying temperature gradient between hot and cold wall.

### **1.3 Objectives and Scope of Study**

#### **1.3.1 Objectives**

In this project, three objectives have been constructed and outlined to deeply study on the natural convection heat transfer by observing flow of fluid in enclosures with varying aspect ratios.

- a) To study natural convection heat transfer at different aspect ratios and different temperature gradient in 3D model enclosures using different fluids
- b) To understand the relationship between Nusselt number, Prandtl number, Rayleigh number and aspect ratio during natural convection heat transfer
- c) To develop correlations for Nusselt number

#### **1.3.2 Scope of Study**

In order to accomplish the objectives in this project, scope of study can be divided into four major categories.

- a) Enclosures with varying aspect ratios ( $0.125 \leq AR \leq 150$ ) will be constructed to study natural convection heat transfer in the cavities.

- b) Three fluids with different properties ( $0.01 \leq Pr \leq 4200$ ) will be used to study the behaviour of fluid in the enclosures.
- c) Cold wall will be maintained at constant room temperature while hot wall of enclosures will be heated up to different temperature to create different  $\Delta T$  (temperature difference, 20K to 100K) across the wall. All the other walls are insulated. Heat transfer of fluid in the cavity will be examined.
- d) Relationship between Nusselt number, Prandtl number, Rayleigh number and aspect ratio will be studied to determine the heat transfer and to develop correlations for Nusselt number.

Figure 3 below displayed the geometry layout of enclosure in this project.

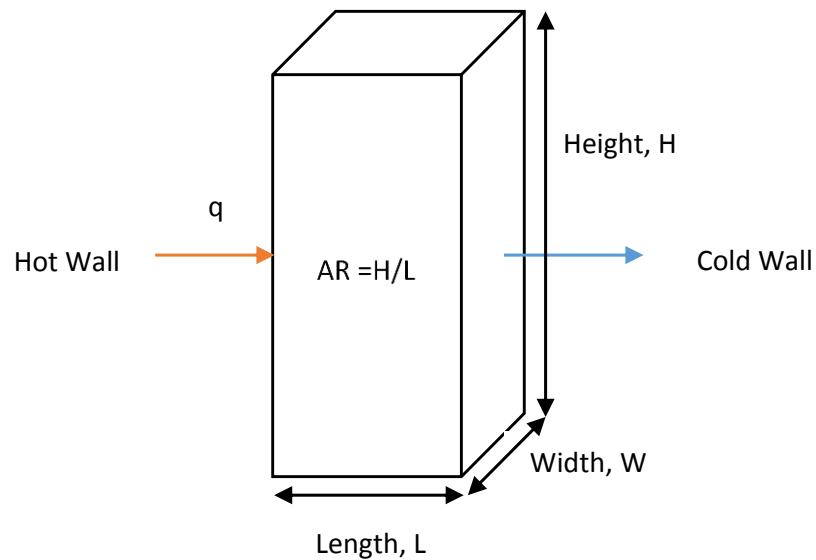

Figure 3: Geometry Layout



## CHAPTER 2

### LITERATURE REVIEW

#### 2.1 Governing Equation

Governing equations that describe mass, momentum and energy transfer for natural convection are originate from the related conservation principles.

##### Mass balance

$$\rho \left( \frac{\partial u}{\partial x} + \frac{\partial u}{\partial y} + \frac{\partial u}{\partial z} \right) = 0 \quad (5)$$

##### Momentum balance

x-direction:

$$\rho \left( \frac{\partial u}{\partial t} + u \frac{\partial u}{\partial x} + v \frac{\partial u}{\partial y} + w \frac{\partial u}{\partial z} \right) = -\frac{\partial p}{\partial x} + \left\{ \frac{\partial}{\partial x} \left( \mu \frac{\partial u}{\partial x} \right) + \frac{\partial}{\partial y} \left( \mu \frac{\partial u}{\partial y} \right) + \frac{\partial}{\partial z} \left( \mu \frac{\partial u}{\partial z} \right) \right\} \quad (6)$$

y-direction:

$$\rho \left( \frac{\partial u}{\partial t} + u \frac{\partial u}{\partial x} + v \frac{\partial u}{\partial y} + w \frac{\partial u}{\partial z} \right) = -\frac{\partial p}{\partial y} + \left\{ \frac{\partial}{\partial x} \left( \mu \frac{\partial u}{\partial x} \right) + \frac{\partial}{\partial y} \left( \mu \frac{\partial u}{\partial y} \right) + \frac{\partial}{\partial z} \left( \mu \frac{\partial u}{\partial z} \right) \right\} + g\beta\Delta T \quad (7)$$

z-direction:

$$\rho \left( \frac{\partial u}{\partial t} + u \frac{\partial u}{\partial x} + v \frac{\partial u}{\partial y} + w \frac{\partial u}{\partial z} \right) = -\frac{\partial p}{\partial z} + \left\{ \frac{\partial}{\partial x} \left( \mu \frac{\partial u}{\partial x} \right) + \frac{\partial}{\partial y} \left( \mu \frac{\partial u}{\partial y} \right) + \frac{\partial}{\partial z} \left( \mu \frac{\partial u}{\partial z} \right) \right\} \quad (8)$$

##### Energy balance

$$\frac{\partial T}{\partial t} + u \frac{\partial T}{\partial x} + v \frac{\partial T}{\partial y} + w \frac{\partial T}{\partial z} = \alpha \left( \frac{\partial^2 T}{\partial x^2} + \frac{\partial^2 T}{\partial y^2} + \frac{\partial^2 T}{\partial z^2} \right) \quad (9)$$

As mentioned in the previous section, circulations of fluid in natural convection heat transfer is mainly due to buoyancy force. If buoyancy force is not large enough to overcome viscous forces, circulation will not occur and heat transfer across the wall will be conductive. Heat flux due to circulation is determined from Newton's Law

$$q = h(T_h - T_c) \quad (10)$$

where  $h$  is the heat transfer coefficient,  $T_c$  and  $T_h$  are cold and hot surface temperatures. The heat transfer coefficient is obtained from Nusselt number correlation equations. Such equations depend on configuration, orientation, aspect ratio, Rayleigh number and Prandtl number.

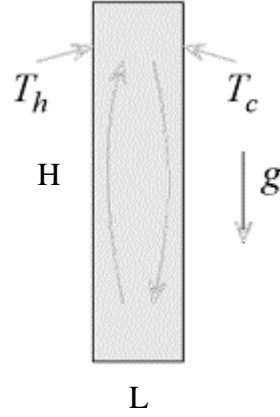

Figure 4: Vertical Rectangular Enclosure

Consider a vertical rectangular enclosure (Figure 4) with one side of the wall has higher temperature than the opposite wall. The other surface will be insulated. The fluid adjacent to the hot surface rises while that near the cold wall falls. This sets up circulation in the cavity resulting in the transfer of heat from the hot to the cold wall. Boundary layers form on the side walls while the core remains stagnant. The aspect ratio  $L/\delta$  is one of the key parameters governing the Nusselt number. Another parameter is the Rayleigh number based on the spacing  $\delta$  and defined as

$$Ra_L = \frac{\beta g (T_h - T_c) \delta^3}{\nu^2} Pr \quad (11)$$

For  $1 < L/\delta < 40$ , the following correlation equations are recommended [1].

$$\overline{Nu}_L = \frac{\bar{h}L}{k} = 0.18 \left[ \frac{Pr}{0.2 + Pr} Ra_L \right]^{0.29} \quad (12)$$

For  $1 < L/\delta < 2$ , the following correlation equations are recommended [2].

$$\overline{Nu}_L = \frac{\bar{h}L}{k} = 0.22 \left[ \frac{Pr}{0.2 + Pr} Ra_L \right]^{0.28} \left[ \frac{H}{L} \right]^{-0.25} \quad (13)$$

Valid for

$$10^{-3} < Pr < 10^5$$

$$\frac{Pr}{0.2 + Pr} Ra_L > 10^3$$

Properties at  $\bar{T} = (T_c + T_h)/2$

For  $1 < L/\delta < 10$ , the following correlation equations are recommended [3].

$$\overline{Nu}_L = \frac{\bar{h}L}{k} = 0.046[Ra_L]^{1/3} \quad (14)$$

Valid for

$$Pr < 10^5$$

$$10^3 < Ra_L < 10^{10}$$

Properties at  $\bar{T} = (T_c + T_h)/2$

For  $1 < L/\delta < 40$ , the following correlation equations are recommended [3].

$$\overline{Nu}_L = \frac{\bar{h}L}{k} = 0.42[Pr]^{0.012}[Ra_L]^{0.25} \left[\frac{H}{L}\right]^{-0.3} \quad (15)$$

Valid for

$$1 < Pr < 20$$

$$10^6 < Ra_L < 10^9$$

Properties at  $\bar{T} = (T_c + T_h)/2$

## 2.2 Previous Work

Over the past decades, there are a lot of studies that have been done on natural convection heat transfer and fluid flow in enclosures with varying aspect ratios. These researches are done through numerical simulation and experimental method. Each of these methods able to clearly study the heat transfer in enclosures and developed appropriate correlation for Nusselt number.

Patterson and Imberger [4] performed research study on transient natural convection. They studied the transient experimental analysis of natural convection heat transfer in a cavity of aspect ratio less than one. Scaling analysis of heat transfer inside a rectangular enclosure was provided by both of the researchers as an outcome of the experiment. In the following year, another experimental study on laminar flow natural

convection across vertical and inclined fluid 1 layer for different enclosures aspect ratios was done by Elsherbiny *et al.* [5]. They developed a correlation for Nusselt number.

$$Nu_1 = 0.0605Ra^{\frac{1}{3}} \quad (16)$$

$$Nu_2 = \left[ 1 + \left[ (0.104Ra^{0.293}) + \left( \frac{6310}{Ra} \right)^{1.36} \right]^3 \right]^{\frac{1}{3}} \quad (17)$$

$$Nu_3 = 0.242 \left( \frac{Ra}{AR} \right)^{0.272} \quad (18)$$

$$Nu = [Nu_1, Nu_2, Nu_3]_{max} \quad (19)$$

Valid for  
 $5 < AR < 110$   
 $1000 < Ra < 10^7$   
 Properties at  $\bar{T} = (T_c + T_h)/2$

Bejan [6] claimed that the relationship between Nusselt Number and Rayleigh number in enclosures with different aspect ratios is complicated and could not be defined through a simple correlation. He confirmed this by showing the natural convection heat transfer flow regimes in different enclosures, for instance tall, square and shallow. Furthermore, with the anticipation on natural convection heat transfer in horizontal and vertical profile, Raithby and Hollands [7] developed a correlation that proves square cavities will have higher Nusselt number compared with high aspect ratio's cavity. Higher value of Nusselt number indicating the system is prone to convective heat transfer. Therefore, based on the correlation by Raithby and Hollands, it can be concluded that convective heat transfer increase with decrease in aspect ratio. Recently, Shati *et al.* [8] came out with a new research that experimentally focused on natural convection heat transfer in between two parallel plates with different aspect ratios. They concluded that increase in aspect ratios will reduce the heat transfer. Hence, in order to verify the effect of aspect ratio on natural convection, different aspect ratios ranging from 0.1 to 150 will be studied in this project.

Prandtl number is also one of the main functions, besides aspect ratios, for determining heat transfer and Nusselt number in enclosures. An experimental study on natural convection was done by Kamotani *et al.* [9] in 1983. They reported that Nusselt number is independent of Prandtl number for aspect ratio equals to one while for aspect ratios less than one, Nusselt number is highly dependent on Prandtl number. In the same year, Lin and Akins [10] studied experimentally the natural convection in cubical enclosure using different kind of fluids ( $6 \leq Pr \leq 9000$ ) and different sizes of cube. Both of the authors declared that Prandtl number does not have an effect on Nusselt number and Rayleigh number. Another recent numerical study by Yu *et al.* [11] on triangular enclosure, concluded that heat transfer in fluid is unique for Prandtl number equals to 0.3. On the other hand, for Prandtl number greater than 0.7, heat transfer is nearly independent on it. One of the simulation studies in year 2006 done by Taha [12] pointed out that the high viscosity of oil has a high value of Prandtl number which inhibit unsteady natural convection that occurred due to buoyant force. High Prandtl number also promote better heat transfer. This is further confirmed in the study done by Nasrin *et al.* [13], they concluded that higher Prandtl number will have greater heat transfer. Nourgaliev *et al.* [14] recommended that experiments should be carried out to validate the strong relationship between Prandtl number and geometry of enclosures. Furthermore, in year 2009, Pessa and Piva [15] reported that higher value of Prandtl number will increase the value of average Nusselt number and this is even more evident in high Rayleigh number. However, Lee and Park [16] proved that this is only true for Rayleigh number  $< 10^3$ . They noticed this in their numerical analysis for Prandtl number dependency on natural convection in an enclosure having a vertical thermal gradient with a square insulator inside. Based on their results, for Rayleigh number  $> 10^3$ , heat transfer is dominated by conduction and is independent of Prandtl number. Since, most literatures shows the relationship between Prandtl number and Nusselt number without considering aspect ratios of enclosures, therefore, this paper will focus on investigating the relationship between Prandtl number, Nusselt number and aspect ratios.

The impact of temperature difference is also worth the investigation besides studying effect of aspect ratios and Prandtl number on natural convection. In year 2009, Ganguli *et al.* [17] studied the temperature distribution across enclosures (2D) with hot wall on the left side and cold wall on the right side. Based on their investigation, they

concluded that temperature distribution and flow pattern in enclosures depends on aspect ratios (Figure 5).

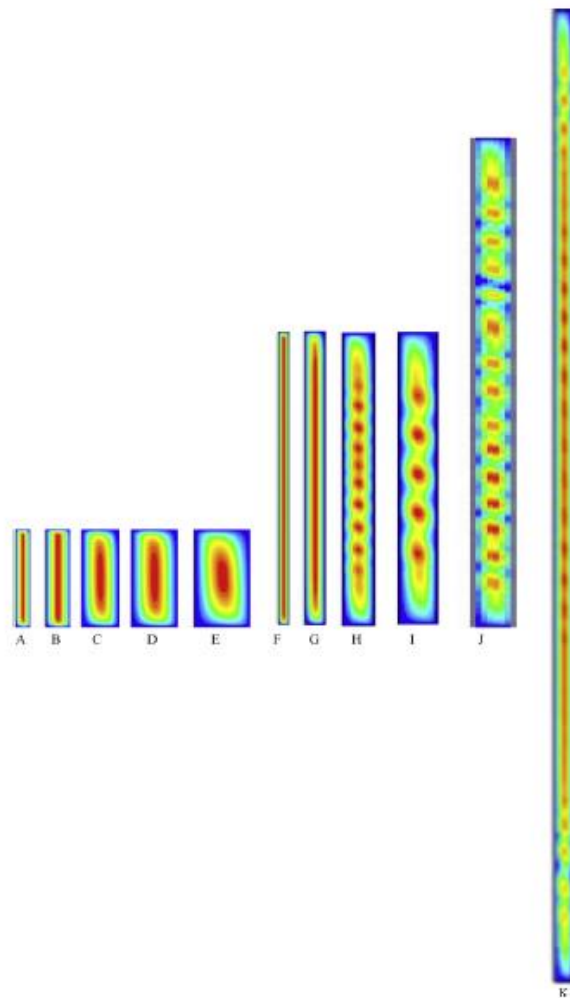

Figure 5: Flow Patterns for Different Aspect Ratios [18]

Aswatha *et al.* [18] studied numerically the effect of different thermal boundary conditions at bottom wall on natural convection in cavities. Temperature of the bottom wall is changing linearly, sinusoidal and uniformly in their simulation. They noticed that uniform temperature at the bottom wall gives the highest Nusselt number. However, relationship between temperature difference and aspect ratios is not investigated. This relationship will be studied in this project to fully analyse natural convection heat transfer and fluid flow in enclosures with different aspect ratios. The relationship between aspect ratios, Prandtl number, Rayleigh number, temperature difference and Nusselt number will also be investigated, which is yet to be studied by previous researchers.

## CHAPTER 3

### METHODOLOGY

In order to achieve the objectives, research methodology of this project is divided into few major parts to accurately and effectively execute the procedures. These major parts of the methodology are critical analysis of literature, data gathering, geometry construction, geometry meshing, setup of model, simulation of the model and post-processing for results obtained.

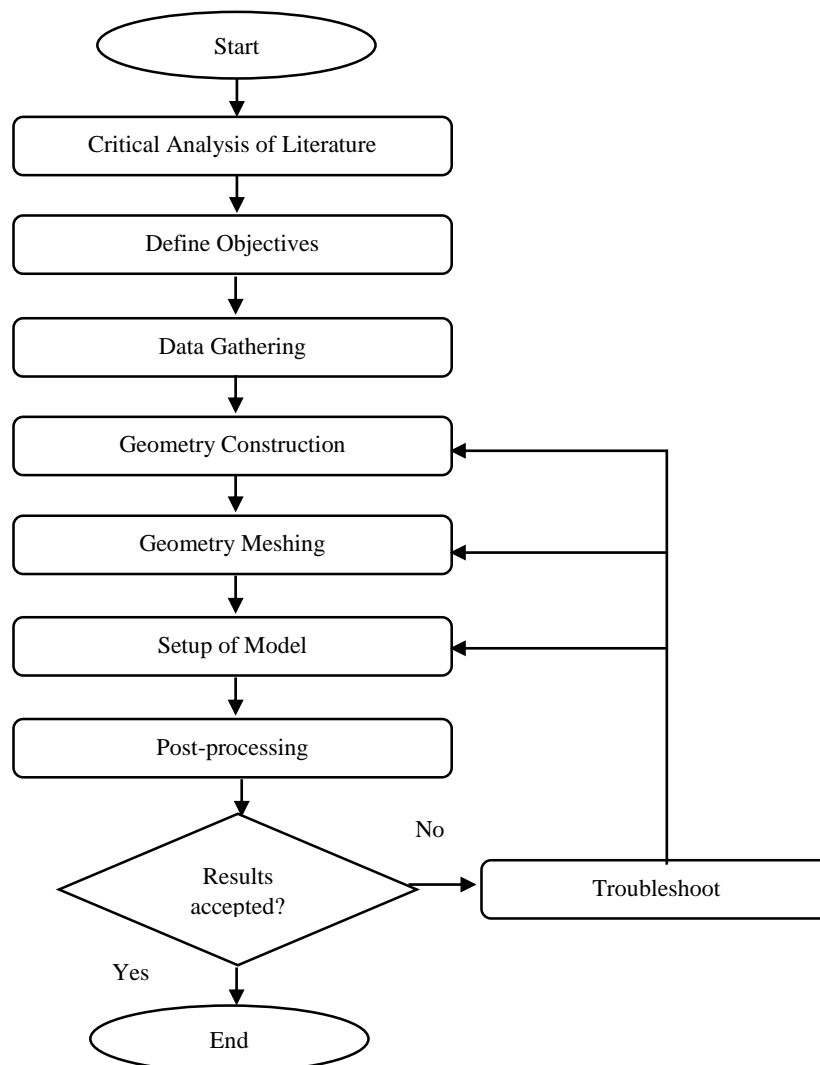

Figure 6: Research Methodology Flowchart

### 3.1 Critical Analysis of Literature

Prior to data gathering, a deep research on the background theory for natural convection heat transfer and fluid flow in enclosures with varying aspect ratios is carried out. A strong foundation on natural convection heat transfer theory is necessary for data gathering and execution of the project procedures. Various research papers are studied and critically analysed in order to have a better understanding on previous works that have been done by others. After analysis of the literature, proper objectives are constructed and studied in this project.

### 3.2 Data Gathering

Data gathering is very important for good quality model development and simulation. In this project, there are few data that need to be collected for development of ANSYS Fluent model. First and foremost, the geometries of enclosures with different aspect ratios are obtained and constructed with the reference previous studies (Table 1).

Table 1: Geometry for Enclosures

Volume (cm <sup>3</sup> )	Width (cm)	Height (cm)	Length (cm)	Aspect Ratio
1000	5	100	2.0	50
1000	5	80	2.5	32
1000	5	60	3.3	18
1000	5	40	5.0	8
1000	5	20	10.0	2
1000	5	10	20	0.5
1000	5	5	40.0	0.125
2000	5	200	2.0	100
2000	5	190	2.1	90
2000	5	180	2.2	81
2000	5	170	2.4	72
2000	5	160	2.5	64
2000	5	150	2.7	56
3000	5	300	2.0	150
3000	5	290	2.1	140
3000	5	280	2.1	131
3000	5	270	2.2	122
3000	5	260	2.3	113

Besides, fluid properties for the three different fluid which are fluid 1, fluid 2 and fluid 3 that have similar properties with air, water and engine oil respectively are collected as well. Table 2 shows properties of fluids that have been used in this project. These thermophysical properties are taken from pervious literature [19].



Table 2: Properties of Fluids

<b>Fluid 1</b>	
<b>Prandtl Number (-)</b>	0.6 – 0.7
<b>Specific Heat (J/kg K)</b>	0.07T + 985.5
<b>Thermal Conductivity (W/m K)</b>	0.02675 – 0.02955
<b>Viscosity (kg/m s)</b>	5E-08T + 2E-06
<b>Fluid 2</b>	
<b>Prandtl Number (-)</b>	1 – 10
<b>Specific Heat (J/kg K)</b>	1E-06T <sup>4</sup> - 0.0017T <sup>3</sup> + 0.876T <sup>2</sup> – 204.24T + 22061
<b>Thermal Conductivity (W/m K)</b>	0.6204 – 0.6694
<b>Viscosity (kg/m s)</b>	3E-11T <sup>4</sup> - 4E-08T <sup>3</sup> + 2E-05T <sup>2</sup> - 0.0053T + 0.4556
<b>Fluid 3</b>	
<b>Prandtl Number (-)</b>	50 – 4200
<b>Specific Heat (J/kg K)</b>	-2E-05T <sup>3</sup> + 0.022T <sup>2</sup> - 4.1115T + 1672.1
<b>Thermal Conductivity (W/m K)</b>	0.1381 – 0.1427
<b>Viscosity (kg/m s)</b>	1E-10T <sup>4</sup> – 6E-08T <sup>3</sup> + 1E-05T <sup>2</sup> + 0.032

### 3.3 Geometry Construction

In this project, natural convection heat transfer has been numerically studied using ANSYS Fluent 15.0. The geometries for all the 3D enclosures are constructed in Design Modeler in ANSYS. All the enclosures are constructed based on some fix steps in different project schematic. First and foremost, a rectangular shape with desired length and height is sketched on a new sketch under XY plane. Extrude technique is then employed on the rectangular sketch to define the width of the enclosures. Finally, the enclosures is defined as fluid body in Design Modeler (Figure 7).

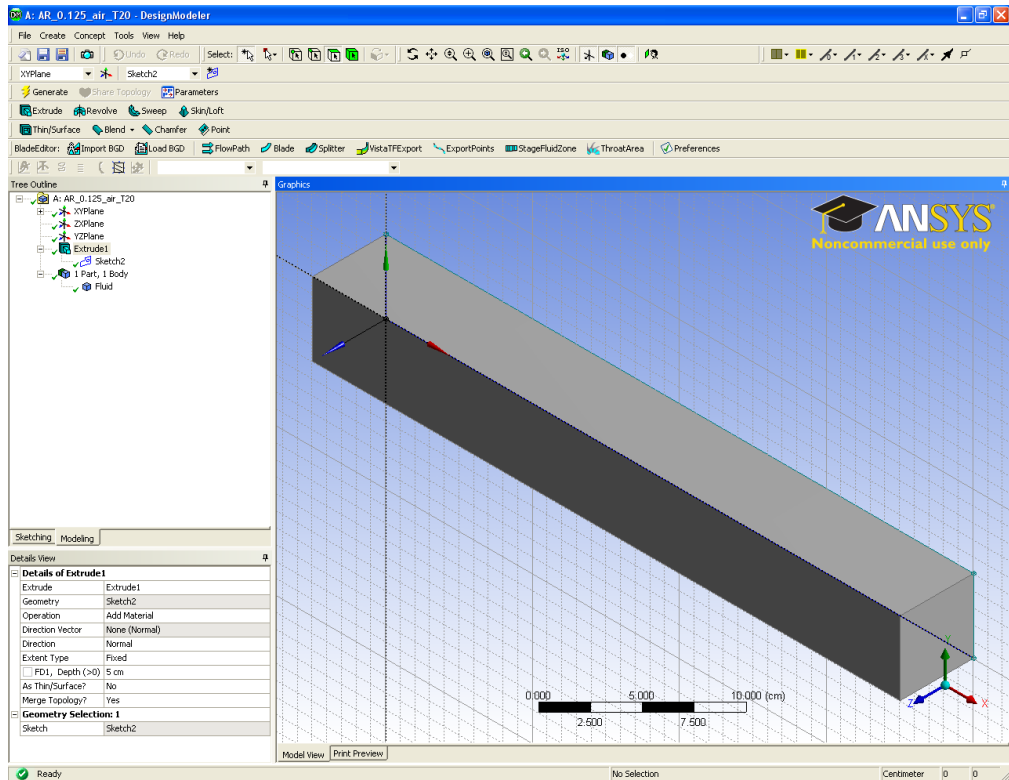

Figure 7: Geometry Construction

### 3.4 Geometry Meshing

After completion of geometry construction, meshing on individual geometry is carried out. In order to obtain higher accuracy for future results, bias mesh size are used throughout this project. The bias mesh option is selected under edge sizing of geometry. Grid sensitivity study is carried out by using different number of division, bias type and bias factor along the edges of geometry. Smaller mesh sizes near the hot wall and cold wall is determined to be the best meshing as it able to more accurately predict the convection current and temperature contour near the edge of enclosures. However, a trial and error on bias factor is conducted to yield the best mesh size for each selected fluid and geometry. Figure 8 below shows meshing of geometry in ANSYS.

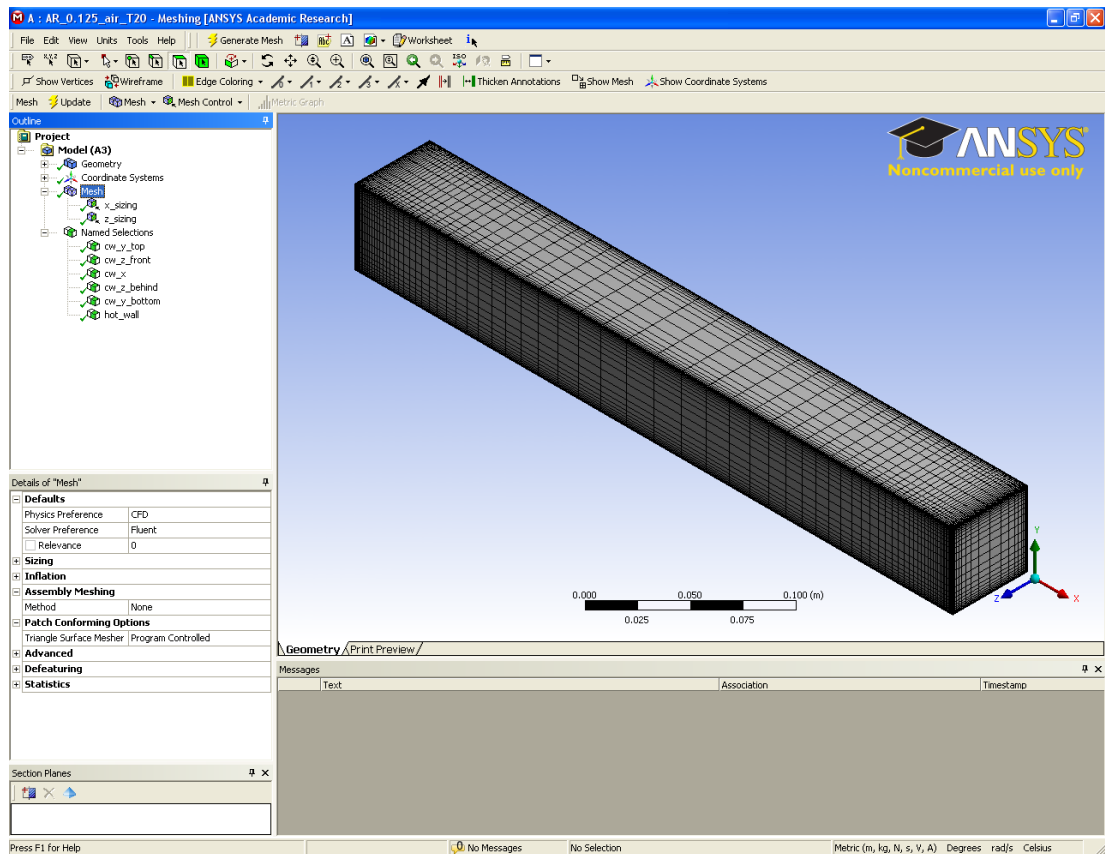

Figure 8: Geometry Meshing

### 3.5 Setup of Model

The model is setup for performing simulation. Type of solver, material used, boundary condition, calculation model to be used, solution method and number of iterations are some of the parameters that need to be defined in model setup. Procedures in setting up the model will be explained in details in following sub-sections.

#### 3.5.1 ANSYS FLUENT Launcher

In order to obtain results with higher accuracy, double precision option is selected in the ANSYS Fluent Launcher (Figure 9).

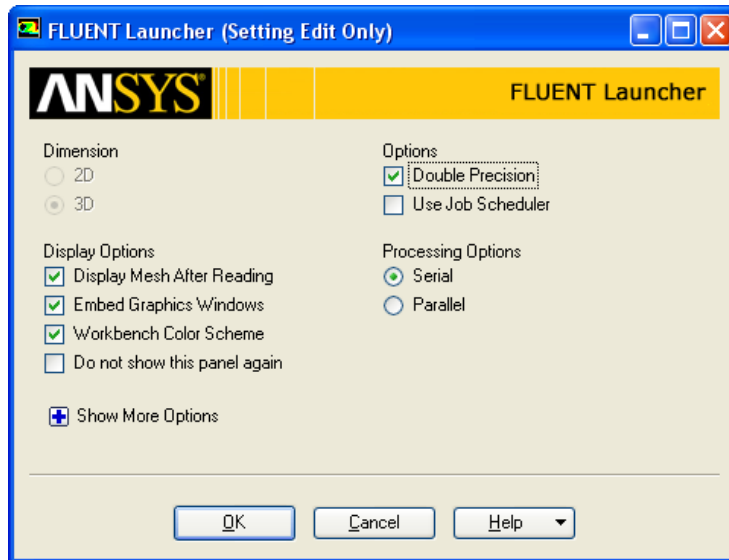

Figure 9: Setting in ANSYS FLUENT Launcher

### 3.5.2 General Setup

In general setup, pressure based solver and absolute velocity formulation is selected due to laminar flow and low velocity of the fluid in the enclosures. Since all the simulations in this project are in steady-state mode (no changes against time), so steady option is selected. Besides, gravitational acceleration is defined to be acting in negative y-direction (Figure 10).

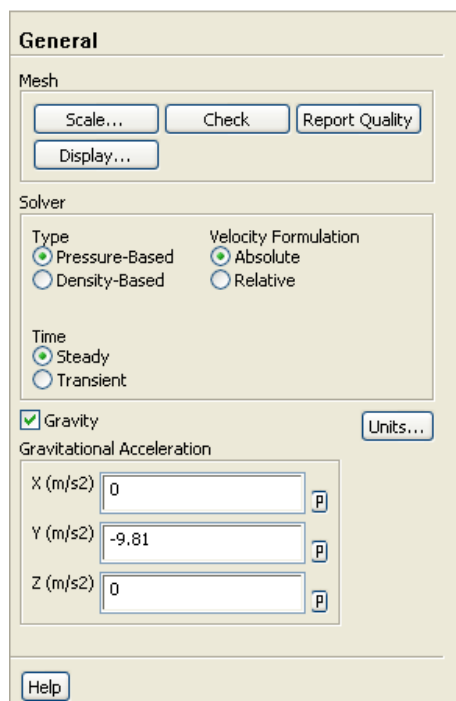

Figure 10: General Setup

### 3.5.3 Model

Under model option, the type of equations for calculation purposes in Fluent are selected (Figure 11). In this project, energy equation, laminar flow model and surface to surface radiation model is turned on to study the natural convection heat transfer and behavior of fluid flow in the enclosures.

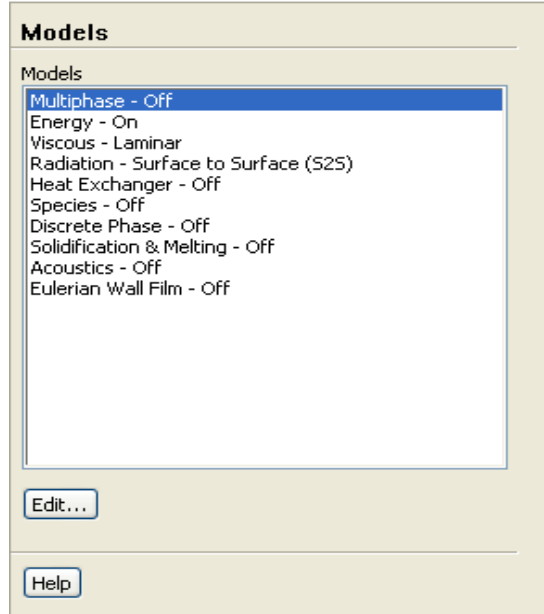

Figure 11: Model turned on

### 3.5.4 Material

Fluid material to be used in this project are fluid 1, fluid 2 and fluid 3. Boussinesq approximation is employed in all models in which density of fluid is assumed to be constant and flow of fluid is mainly due to buoyant force (Figure 12). Thermophysical properties of fluid displayed in Table 2 are used to perform simulations in this project.

$$\text{Boussinesq approximation: } \rho = \rho_o[1 - \beta(T - T_o)] \quad (20)$$

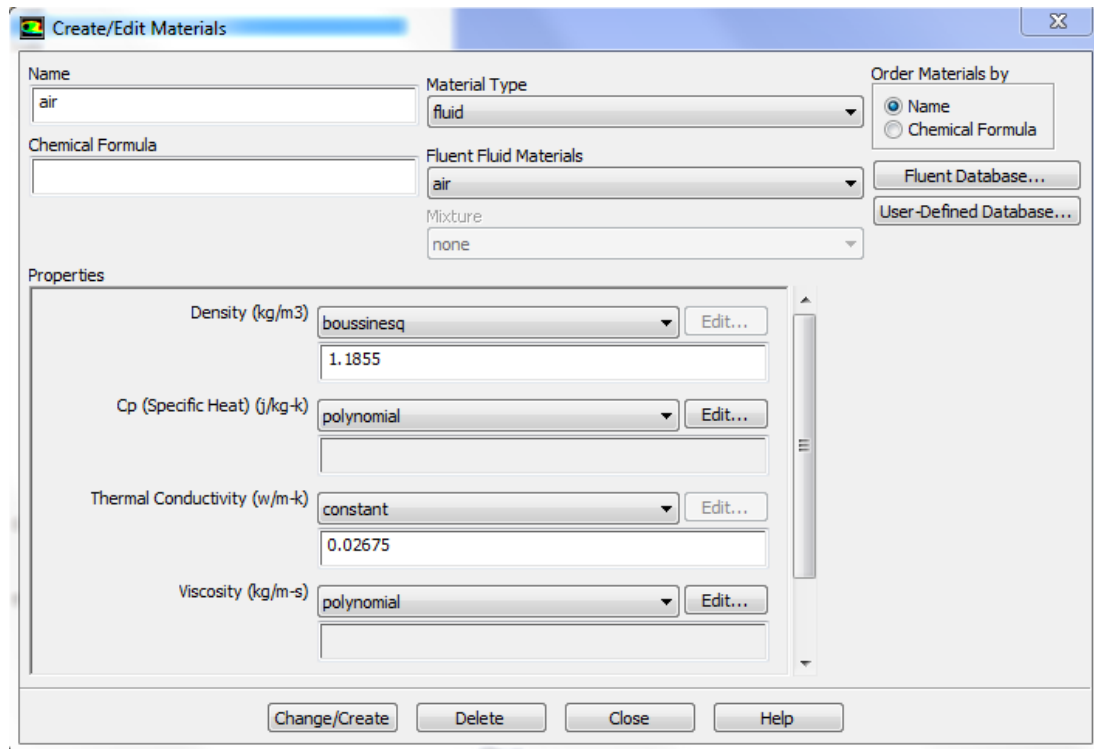

Figure 12: Properties of Fluids Inserted in Fluent

Insulation material is introduced to all the walls except hot wall that uses aluminum as the material. Properties of aluminum are taking from Fluent Database. Below shows the properties of insulation material.

- Density:  $50 \text{ kg/m}^3$
- Specific heat capacity:  $800 \text{ J/kg K}$
- Thermal conductivity:  $0.09 \text{ W/m K}$

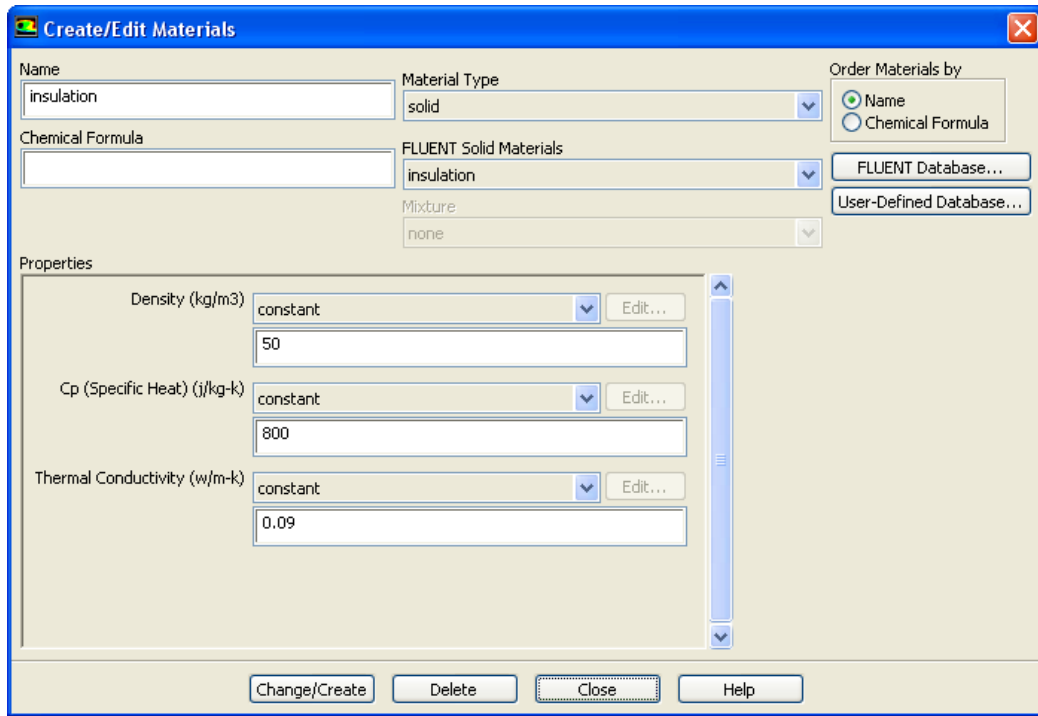

Figure 13: Insulation Material

### 3.5.5 Boundary Condition

In boundary condition section, the temperature, materials and conditions of all the walls are defined (Figure 14 - 15). Temperature of walls are defined under the thermal tab. In this project, temperature of hot wall is increased from 318.15K to 398.15K and temperature of all the other insulated walls are set constant at 298.15K to create delta T ranging from 20K to 100K. Furthermore, the material for hot wall is aluminum and material for insulated wall is insulation.

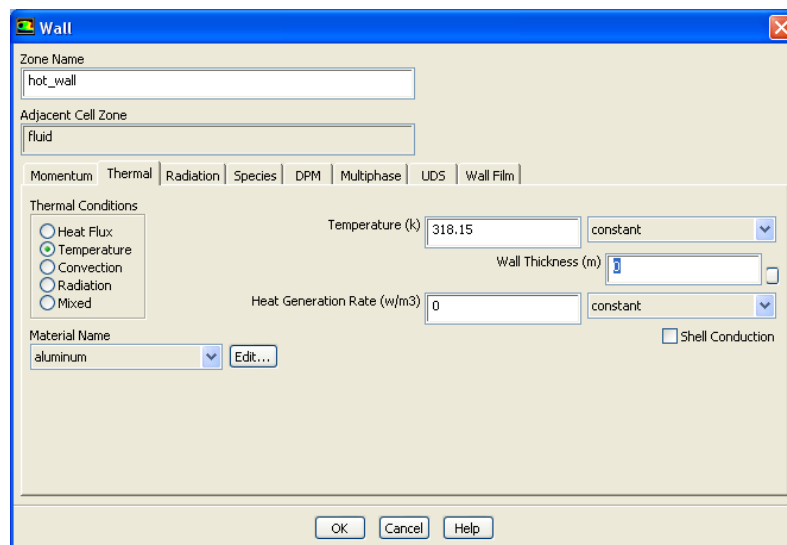

Figure 14: Hot wall boundary condition

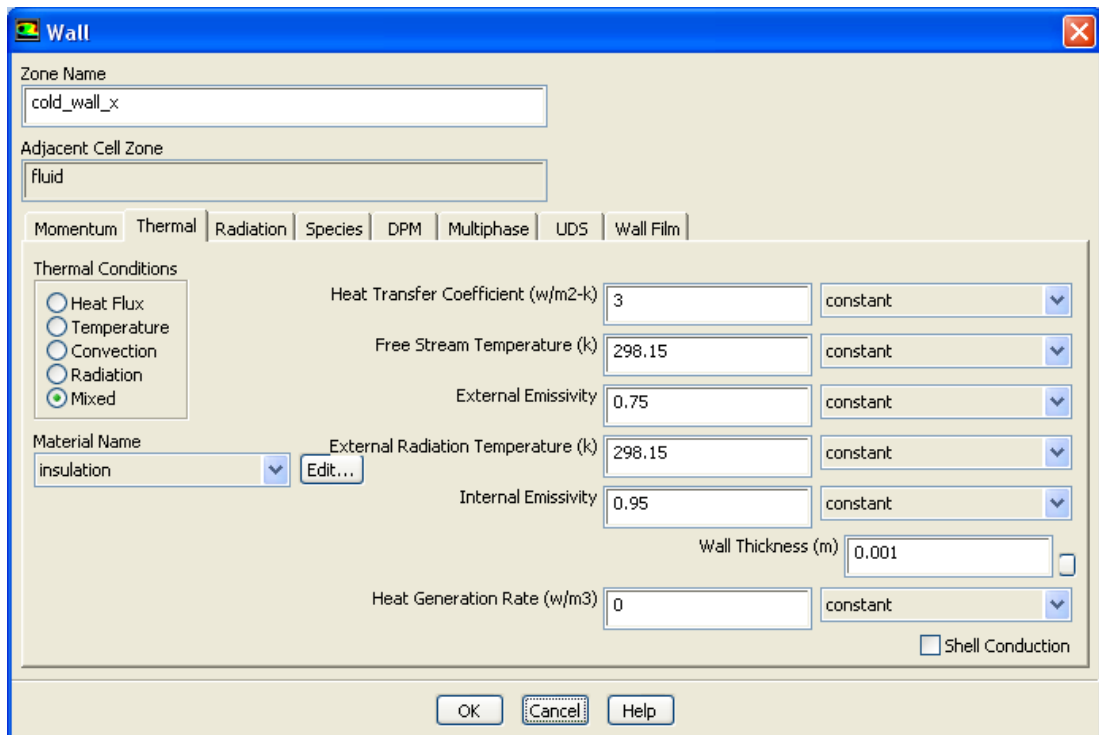

Figure 15: Insulated wall boundary condition

### 3.5.6 Operating Condition

Atmospheric pressure is set to be the operating pressure in this project. Define of operating temperature is necessary as well for the calculation of density using Boussinesq approximation. The operating temperature in this project is 298.15K (Figure 16).

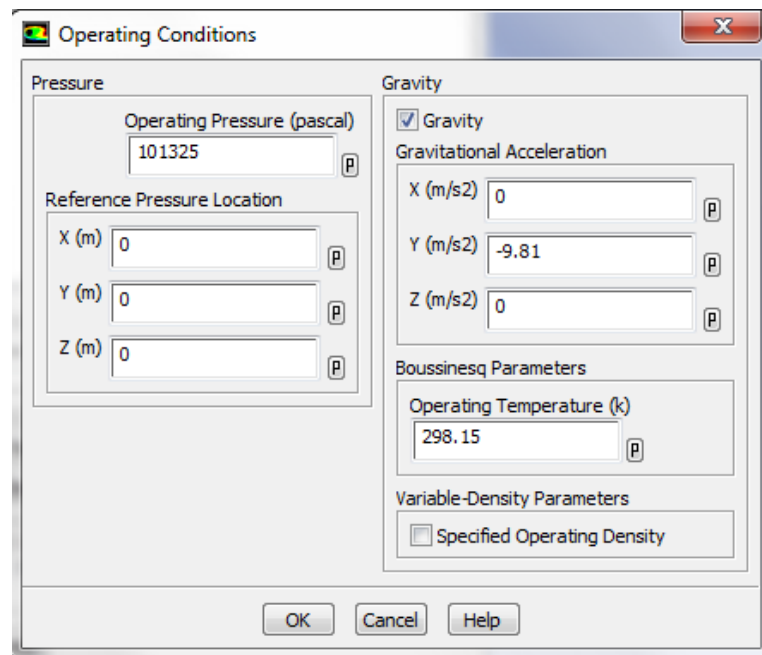

Figure 16: Operating Conditions



### 3.5.7 Solution Method

In the solution method, coupled scheme is selected under the pressure-velocity coupling. The pressure-based coupled algorithm obtains a more robust and efficient single phase implementation for steady – state flow. Besides this, spatial discretization scheme is also set under the solution method (Figure 17).

#### *Spatial Discretization*

Gradient: Least square cell based (suitable for regular structure and is more efficient to compute compared to node-based gradient)

Pressure: Body force weighted (works well for buoyancy calculation)

Momentum, Energy: Third-Order MUSCL (provide better accuracy)

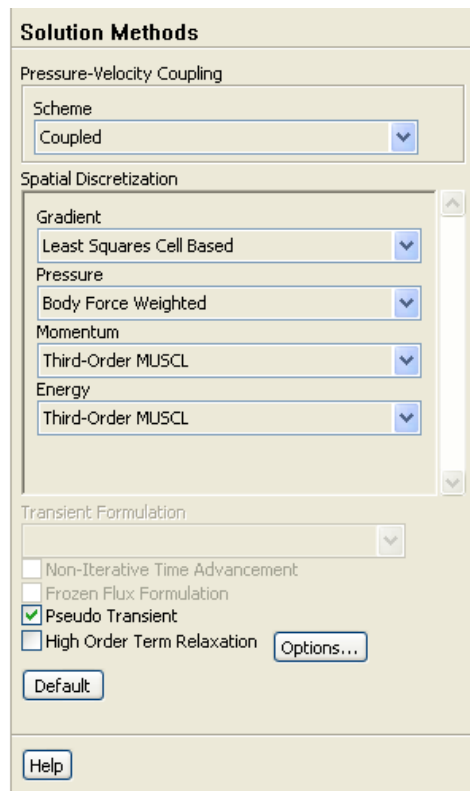

Figure 17: Setup of Solution Method

Third-order monotone upstream centered schemes for conservation laws (MUSCL) is generally employed for discretization of momentum and energy of fluid 1 in all the enclosures to obtain higher accuracy results. For fluid 2 and 3, first-order upwind discretization scheme is used. Results obtained by first-order upwind are acceptable and reliable as well due to simple geometry and mesh elements.

### 3.5.8 Residual Monitors

Residual computed in ANSYS Fluent referred as the “unscaled” residual. The smaller the residual values, the more accurate is the converged results. In this project, the residuals for continuity, x-velocity, y-velocity and z-velocity is set to 1E-05 while residual for energy is set to 1E-08 to obtain better converged results (Figure 18).

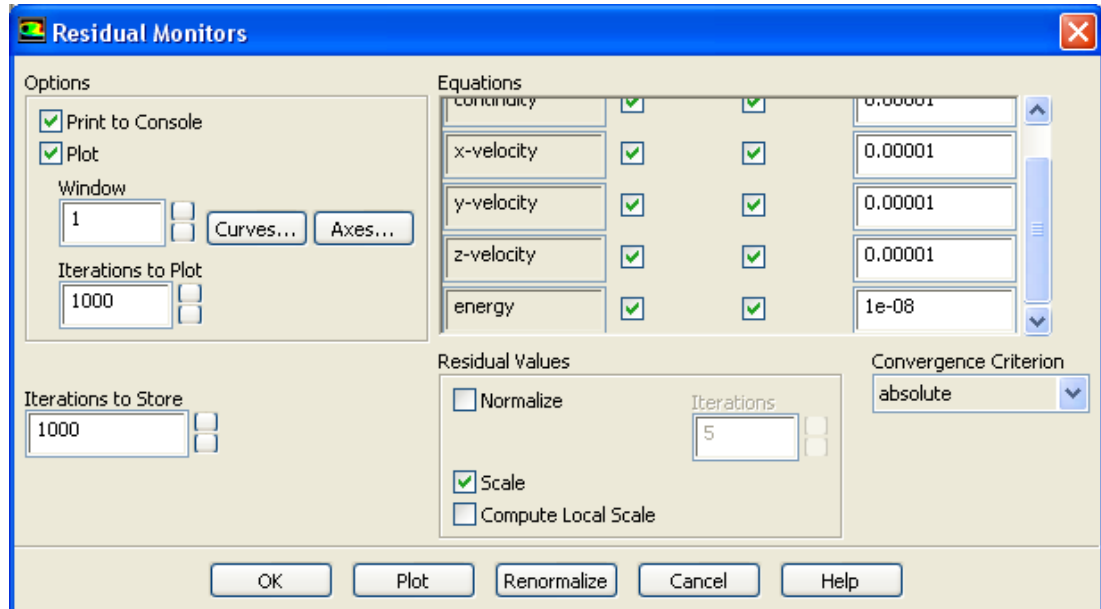

Figure 18: Residuals Monitor

### 3.5.9 Solution Initialization

There are two method to initialize the solution in ANSYS Fluent which are hybrid initialization and standard initialization. Hybrid initialization is selected in this project as it is recommended for pressure-base coupled scheme solver. Hybrid initialization provides convergence robustness of simulation (Figure 19).

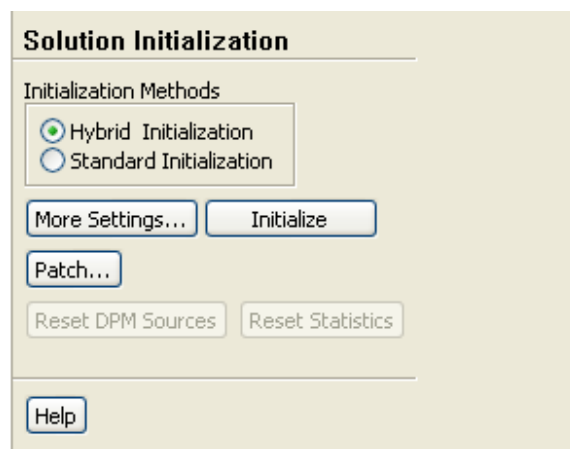

Figure 19: Solution Initialization

### **3.6 Post-processing**

Post-processing of the results are carried in order to analyse the results after simulations are performed. Temperature contour, velocity contour and velocity vector are plotted to study the natural convection heat transfer and fluid flow in 3D enclosure model. In this stage, inadequacy of simulation is detected and troubleshooting the model will be carried out as well. Simulation will be re-performed on the updated model and results will be extracted and analysed again. After the results have been finalized, graphs of Nusselt Number and heat transfer coefficient versus aspect ratios are plotted.

Table 3 – 4 displayed the gantt chart and key milestone for this project in two semesters.

Table 3: Gantt Chart

Project Flow/Task	FYP I (Week)														FYP II (Week)													
	1	2	3	4	5	6	7	8	9	10	11	12	13	14	1	2	3	4	5	6	7	8	9	10	11	12	13	14
Confirmation of Project Title	█	█																										
Critical Analysis of Literature			█	█	█																							
Define Objectives				█	█																							
Proposed Methodology				█	█																							
Data Gathering					█																							
Geometry Construction					█	█																						
Geometry Meshing						█																						
Setup of Model							█	█																				
Performed Simulation								█	█	█	█	█	█	█		█												
Post Processing of Results														█	█	█	█	█	█	█	█							
Correlation Development																						█	█	█				
Project Wrap Up																									█	█		

Table 4: Key Milestone

Milestone	FYP I (Week)														FYP II (Week)													
	1	2	3	4	5	6	7	8	9	10	11	12	13	14	1	2	3	4	5	6	7	8	9	10	11	12	13	14
Confirmation of Project Title		√																										
Critical Analysis of Literature					√																							
Data Collection					√																							
Extended Proposal Submission							√																					
Proposal Defence								√																				
Model Development									√																			
Interim Report Submission												√																
ANSYS FLUENT Simulation																√												
Post-processing Result																			√									
Progress Report Submission																				√								
Correlation Development																							√					
Project Wrap Up																							√					
Pre-SEDEX																								√				
Draft Final Report Submission																								√				
Dissertation Softcopy Submission																									√			
Technical Paper Submission																									√			
Viva																											√	
Dissertation Hardcopy Submission																											√	

## **CHAPTER 4**

### **RESULTS AND DISCUSSION**

Simulation on enclosures with aspect ratio ranging from 0.125 to 150 using fluid 1, fluid 2 and fluid 3 as working fluids have been numerically studied. The heat transfer of fluid in the enclosures are studied by changing the temperature of hot wall to create different  $\Delta T$  with the insulated wall ( $20K \leq \Delta T \leq 100K$ ). In order to comprehensively analyse the heat transfer performance in enclosures, an iso-surface in the middle of enclosures with z-coordinate (width of enclosure) equals to 0.025m is created. Temperature and velocity contours are display in the iso-surface to study the effects of aspect ratios towards heat transfer and fluid flow in enclosures.

#### **4.1 Effect of Aspect Ratio and Fluid Properties on Heat Transfer Performance**

Heat transfer performance of fluids in enclosures are studied by observing temperature contour exhibits in the iso-surface created. Figure 20 displays the temperature contours in certain enclosures with aspect ratios ranging from 0.125 to 50 for fluid 1, fluid 2 and fluid 3 at temperature gradient of 60K. From the figures, it can be seen that average temperature in the enclosures increase with aspect ratio. This is proved in Figure 21 in which static temperature which is the average temperature increases as aspect ratio increases. This is because of increase in aspect ratio indicates an increase in height of enclosures and decrease in length of respective enclosures. Therefore, increase in aspect ratios reflects the increase in surface area of hot wall. This causes enhanced in heat transfer performance from hot wall to cold wall and hence average temperature in the enclosures is increased. It is observed that fluid 2 gives highest static temperature compared to fluid 3 and fluid 1, shown in Figure 20 – 22. This can be explained by the specific heat capacity of fluid 2. Figure 22 shows that fluid 2 is having highest specific heat capacity among the three fluids followed by fluid 3 and fluid 1.

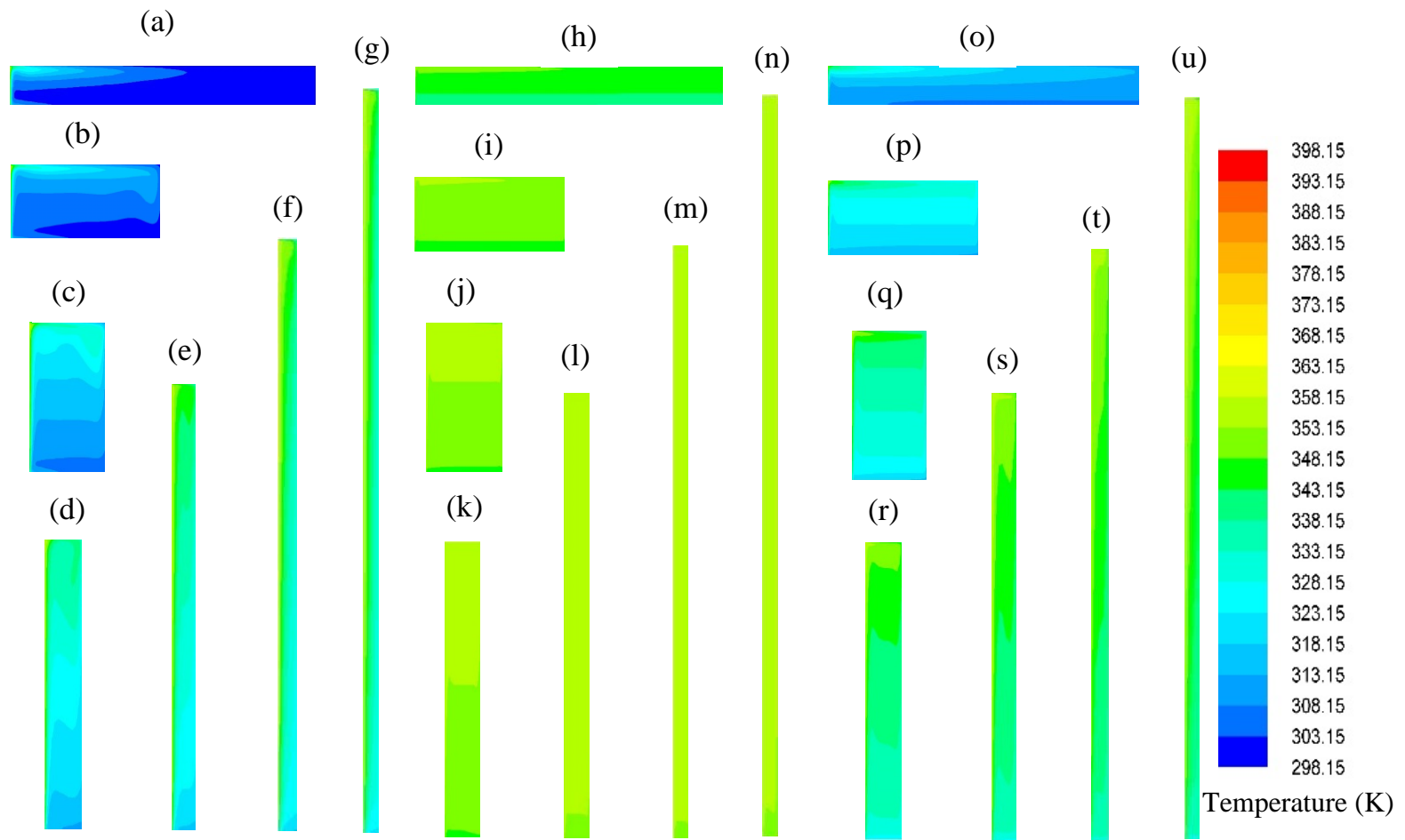

Figure 20: Temperature distribution in enclosure for  $\Delta T = 60$  K in (a) – (g) Fluid 1, AR = 0.125, 0.5, 2, 8, 18, 32, 50; (h) – (n) Fluid 2, AR = 0.125, 0.5, 2, 8, 18, 32, 50; (o) – (u) Fluid 3, AR = 0.125, 0.5, 2, 8, 18, 32, 50

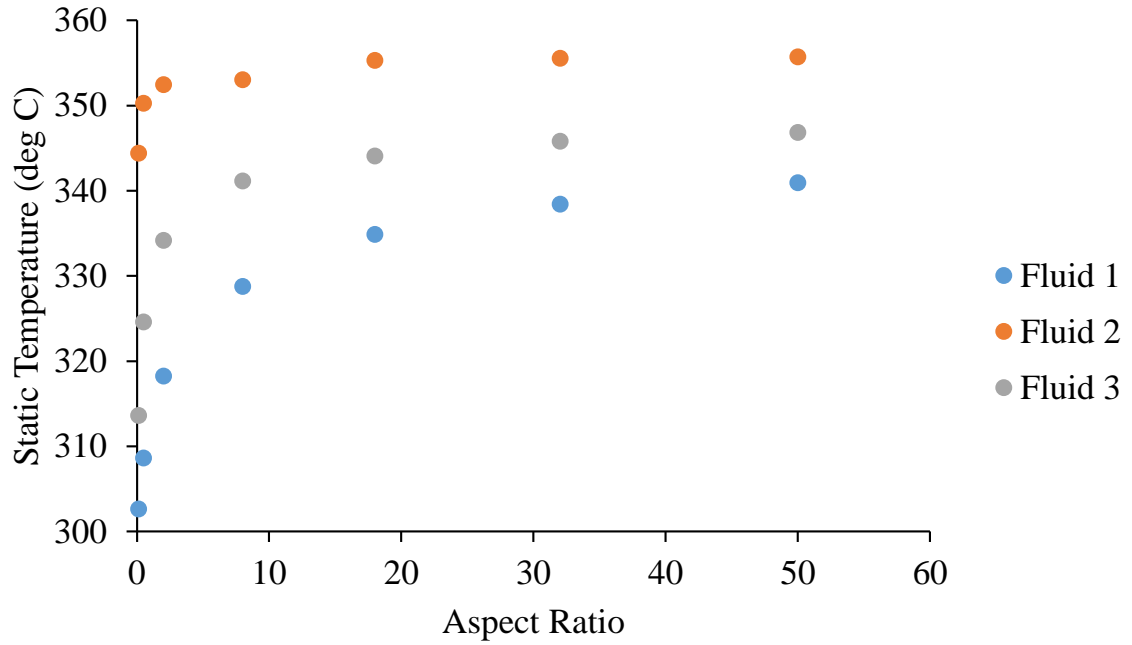

Figure 21: Variation of Static Temperature with Aspect Ratio for Fluid 1, Fluid 2 and Fluid 3 at Temperature Difference of 60K

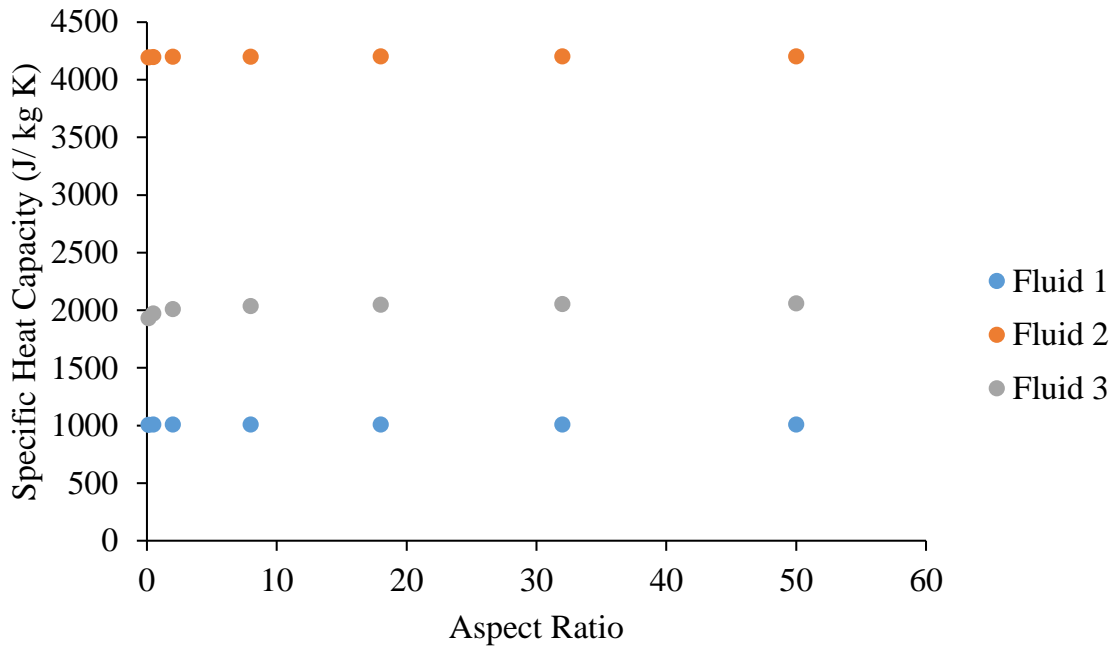

Figure 22: Variation of Specific Heat Capacity with Aspect Ratio for Fluid 1, Fluid 2 and Fluid 3 at Temperature Difference of 60K



#### **4.2 Effect of Aspect Ratio and Fluid Properties on Fluid Flow**

Flow of fluid in enclosures are analysed by observing velocity vector for iso-surface at z-coordinate (width of enclosures) equals to 0.025m. Figure 23 displayed velocity vector in certain enclosures with aspect ratios ranging from 0.5 to 18 for fluid 1 at temperature gradient of 100K. Based on the figures, it is noticeable that velocity of fluid is higher in enclosures with higher aspect ratio. This can be explained by the increase in surface area of hot wall which causes improved in heat transfer performance and static temperature. Density is known to have an inverse relationship with temperature, therefore, low density of fluid is expected under high temperature. Low density fluid increase the ease of flow as well as velocity. So, it can be concluded that velocity of fluid increase with aspect ratio. Furthermore, it can be seen that fluid 1 gives highest velocity followed by fluid 2 and fluid 3. This is because fluid 1 is having lowest viscosity, as shown in Figure 24.

It is noticeable that the fluid flow direction is in circulation manner which reflects the natural convection phenomena. In natural convection, fluid flow due to density difference which induced a buoyancy force and cause the fluid to flow. Fluid particles that near to hot wall will be heated up and density will reduced. Hence, the fluid will flow to the upper part of enclosure where the temperature is lower. These fluid particles will again be cooled down and density will increased. Fluid particles with higher density will move towards the lower part of enclosure due to gravitational force. The cycle will repeat and cause the circular motion of fluid in the enclosures.

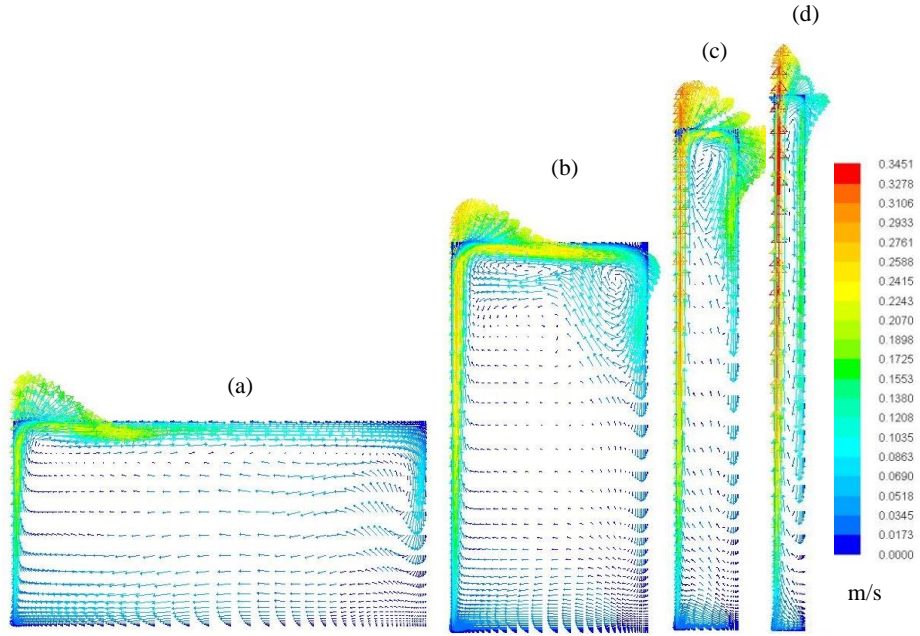

Figure 23: Velocity vector for fluid 1 at temperature gradient of 100K (a) AR = 0.5; (b) AR = 2; (c) AR = 8; (d) AR = 18

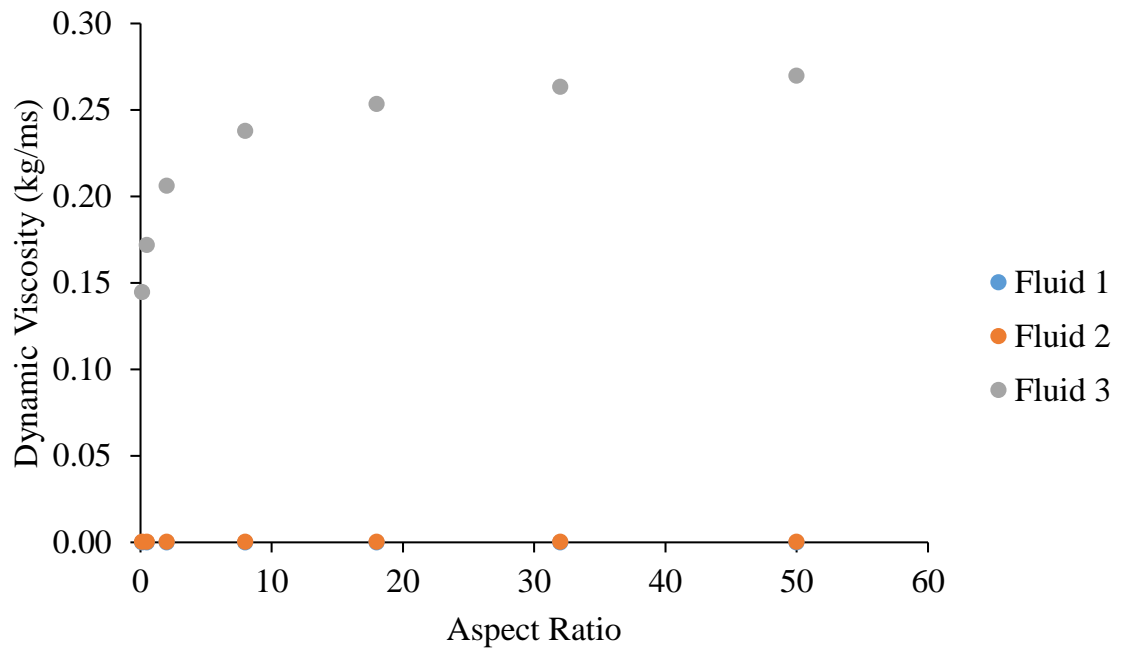

Figure 24: Variation of Viscosity with Aspect Ratio for Fluid 1, Fluid 2 and Fluid 3 at Temperature Difference of 100K

### **4.3 Effect of temperature difference and aspect ratio on Nusselt number**

Nusselt number (ratio of convective to conductive heat transfer) is analyzed extensively to understand the effect of aspect ratio on heat transfer performance in rectangular enclosures using different fluids. The variation of Nusselt number with aspect ratios for fluid 1, fluid 2 and fluid 3 at different temperature gradient are shown in Figure 25 - 27. Nusselt number is highly dependent on aspect ratio, type of fluids and temperature gradient between hot and cold wall. It is observed that for a constant aspect ratio, Nusselt number increases as temperature gradient increase. Heat transfer coefficient is mainly governed by flow regime in the enclosures. Flow regime of fluids in enclosures can be divided into three categories: conduction flow regime, transition flow regime and boundary layer flow regime [17].

Aspect ratio of 0.5 exhibits highest value of Nusselt number, shown in Figure 25 - 27, due to convective dominated heat transfer in this enclosure. Temperature distribution contours of AR = 0.5 at  $\Delta T = 100$  K for fluid 1 are shown in Figure 28 (a). It is found that heat transfer in this enclosure falls in boundary layer flow regimes in which conductive heat transfer is limited to thin boundary layer near the wall of enclosure and majority of the fluid region exhibits convective heat transfer. Similar trends are observed in natural convection of fluid 2 and fluid 3. Temperature distribution contours of AR = 18 at  $\Delta T = 100$  K for fluid 1 displays in Figure 28(b) shows that the heat transfer performance in enclosure is considered to be in the transition regime. This is because of convective heat transfer in fluid region decreases while conductive heat transfer near the wall increases which causes decrease in Nusselt number. The results showed similar behavior with previous literature [17]. Lower values of Nusselt number are seen in AR = 50 at  $\Delta T = 100$  K for fluid 1. The heat transfer in this enclosure is concluded to be governed by conduction because linear temperature distribution in the enclosure is observed, shown in Figure 28 (c). Similar heat transfer behavior is seen for fluid 2 and fluid 3, shown in Figure 28 (f) and Figure 28 (i) respectively. It can be concluded that heat transfer in enclosures with low aspect ratio is generally governed by convection while high aspect ratio is dominated by conduction [7]. To enhance convective heat transfer in enclosure, increase in temperature difference across hot and cold wall of enclosure is necessary.

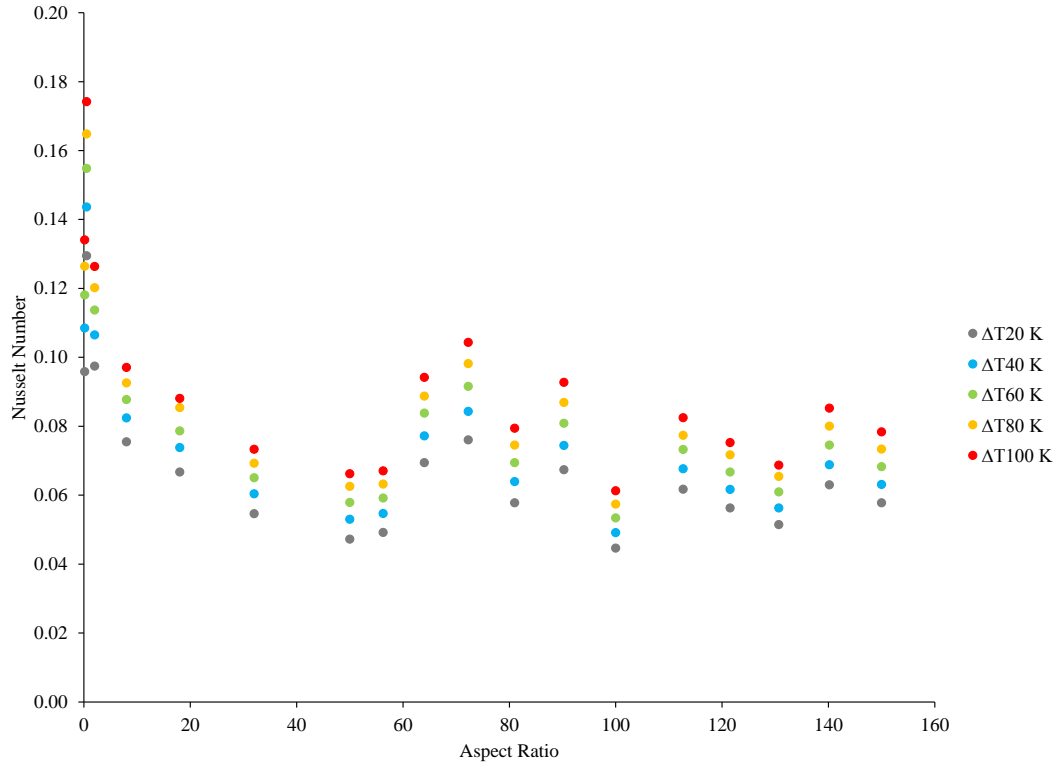

Figure 25: Variation of Nusselt Number with Aspect Ratio for Fluid 1

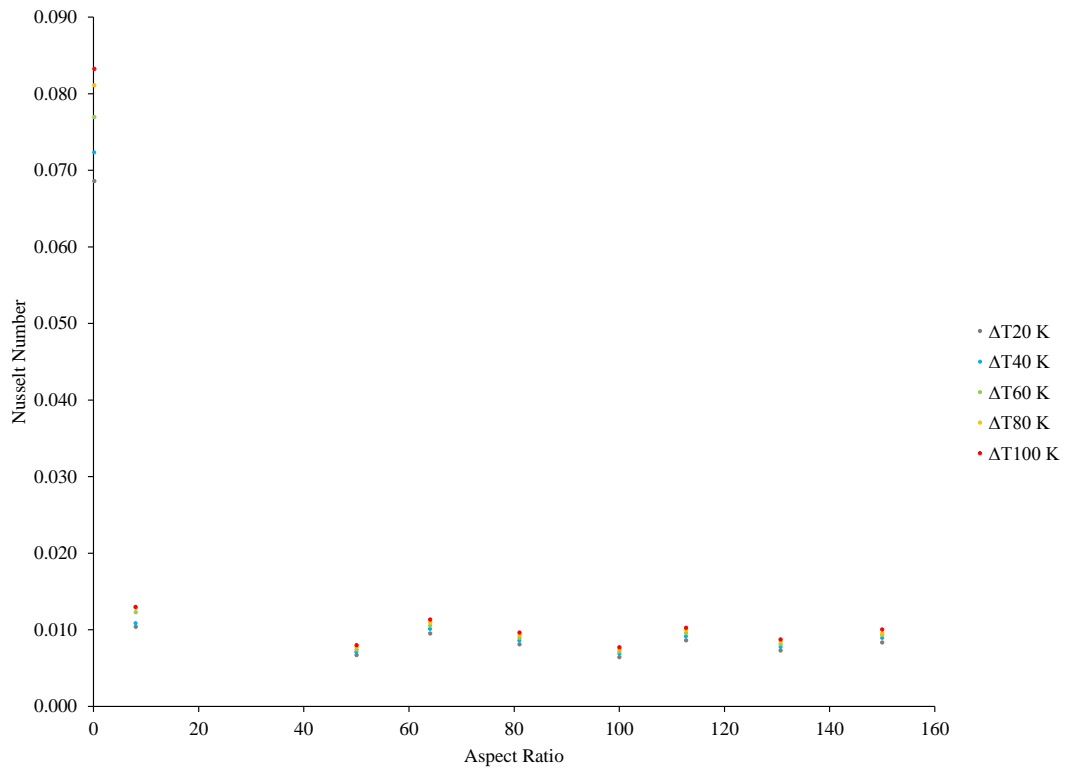

Figure 26: Variation of Nusselt Number with Aspect Ratio for Fluid 2

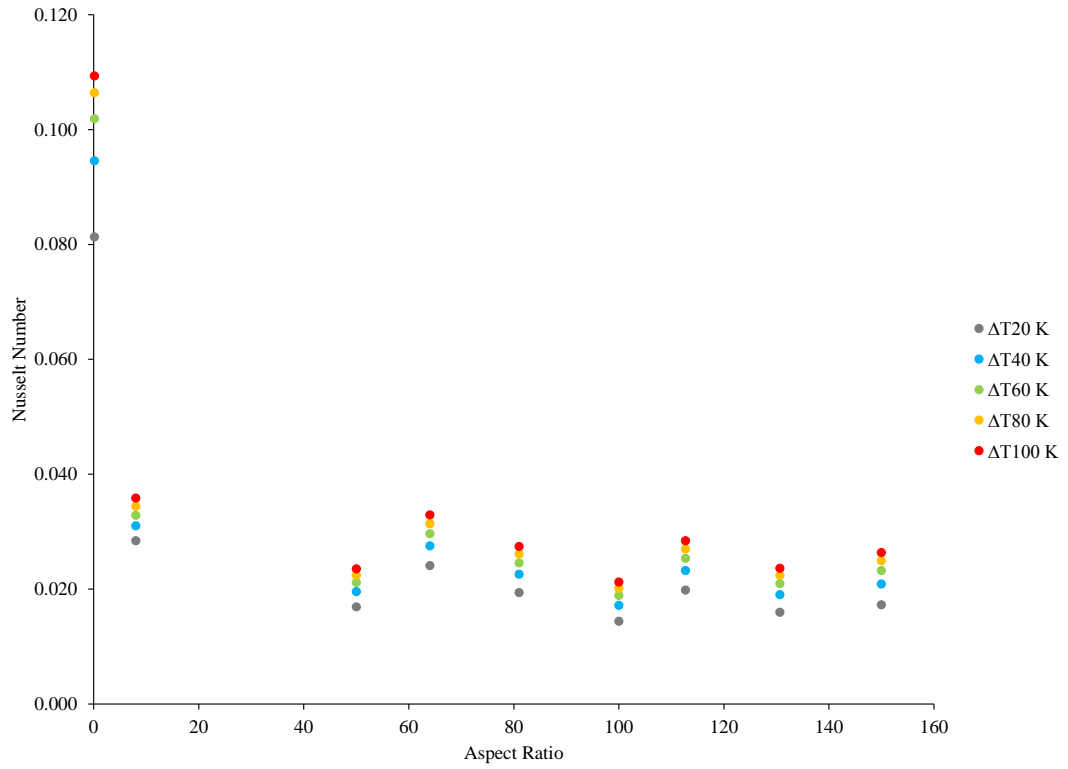

Figure 27: Variation of Nusselt Number with Aspect Ratio for Fluid 3

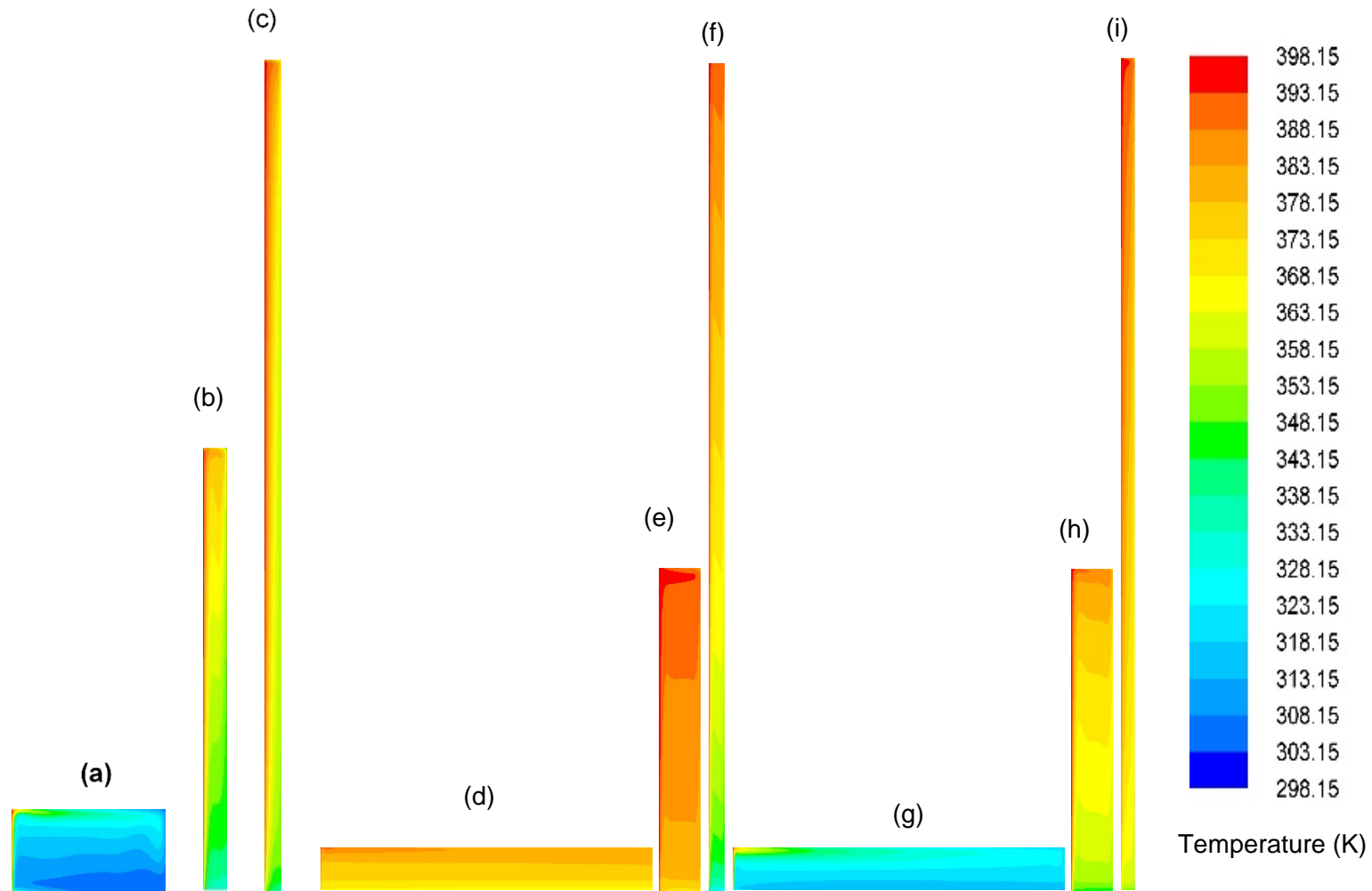

Figure 28: Temperature distribution in enclosure for  $\Delta T = 100$  K in (a) AR = 0.5, fluid 1; (b) AR = 18, fluid 1; (c) AR = 50, fluid 1; (d) AR = 0.125, fluid 2; (e) AR = 8, fluid 2; (f) AR = 50, fluid 2; (g) AR = 0.125, fluid 3; (h) AR = 8, fluid 3; (i) AR = 50, fluid 3.

#### **4.4 Effect of aspect ratio on flow patterns for different fluid**

Simulations are performed at different aspect ratios for various fluids to study the fluid flow properties. Velocity contours of fluid 1, fluid 2 and fluid 3 in iso-surface for  $AR = 0.125$  to  $AR = 50$  with temperature difference of 100 K are shown in Figure 29. It is found that heat transfer coefficient of fluids during natural convection are mainly governed by flow regime in the enclosures. Multicellular flow formation is seen in the enclosures with low aspect ratios, shown in Figure 29 (a), 29 (d) and 29 (g). Formation of unequally distributed multiple cells indicates that heat transfer in the liquid region of enclosures are dominated by convective heat transfer. However unequally distributed multicellular flow are observed in enclosures with low aspect ratios. Multicellular flow patterns are observed to be disappeared with the increase in aspect ratio and only unicellular flow is observed, shown in Figure 29.

Convective heat transfer performance in unicellular flow is poor and heat transfer is dominated by mainly conductive heat transfer only. Variation in heat transfer coefficient at different aspect ratios for fluid 1, fluid 2 and fluid 3 with temperature gradient from 20 K to 100 K is shown in Figure 30 - 32. Enclosures with high aspect ratios demonstrate higher values of heat transfer coefficient. However, due to conductive dominated heat transfer performance, high aspect ratio enclosures show low values of Nusselt number (Figure 25 - 27). Therefore, it can be concluded that enclosures with low aspect ratios gives better convective heat transfer performance due to formation of multicellular flow pattern in enclosures [17].

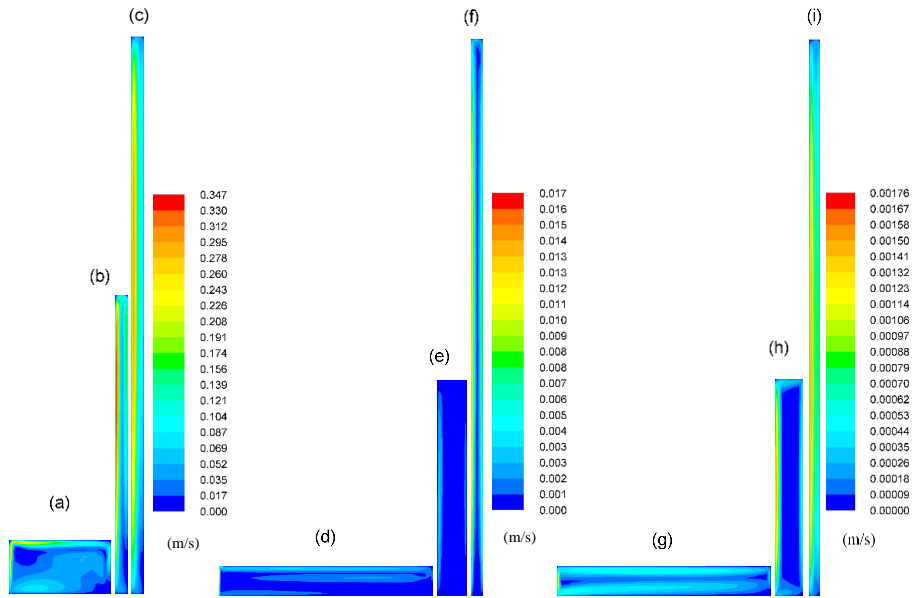

Figure 29: Velocity distribution in enclosure for  $\Delta T = 100$  K in (a) AR = 0.5, fluid 1; (b) AR = 18, fluid 1; (c) AR = 50, fluid 1; (d) AR = 0.125, fluid 2; (e) AR = 8, fluid 2; (f) AR = 50, fluid 2; (g) AR = 0.125, fluid 3; (h) AR = 8, fluid 3; (i) AR = 50, fluid 3.

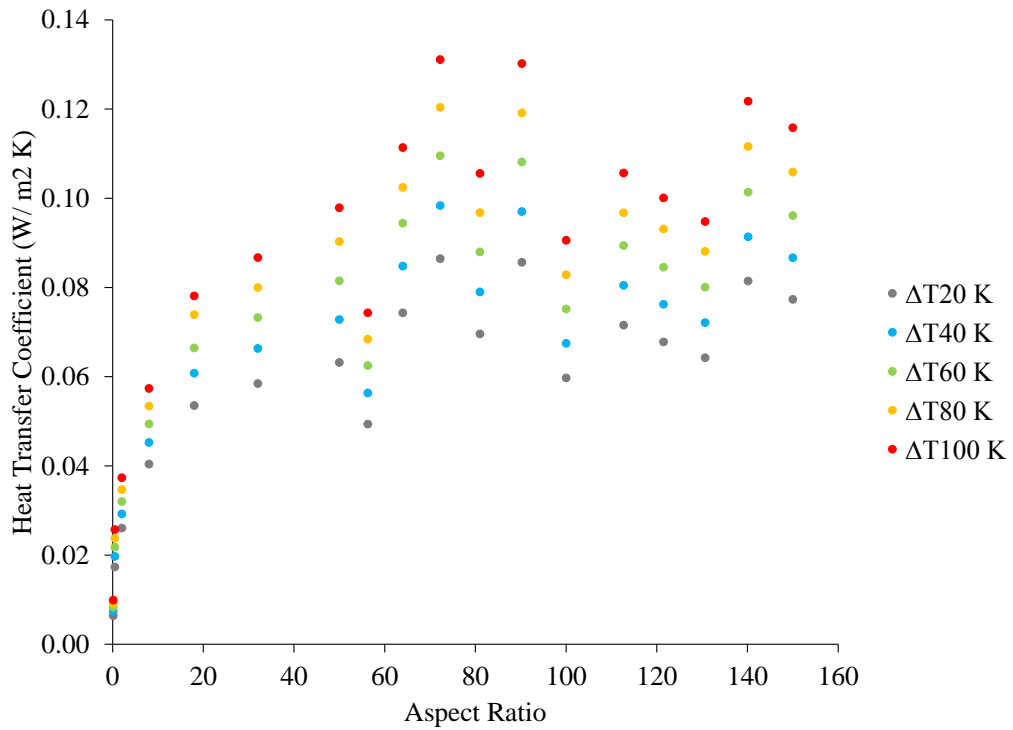

Figure 30: Variation of Heat Transfer Coefficient with Aspect Ratio for Fluid 1



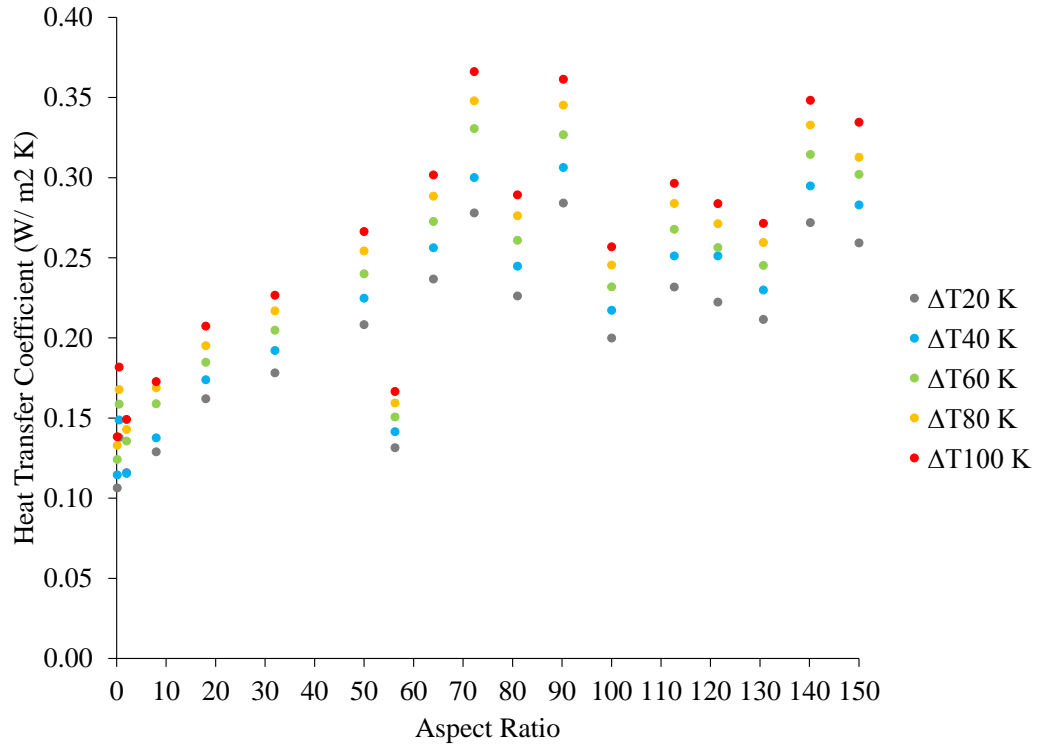

Figure 31: Variation of Heat Transfer Coefficient with Aspect Ratio for Fluid 2

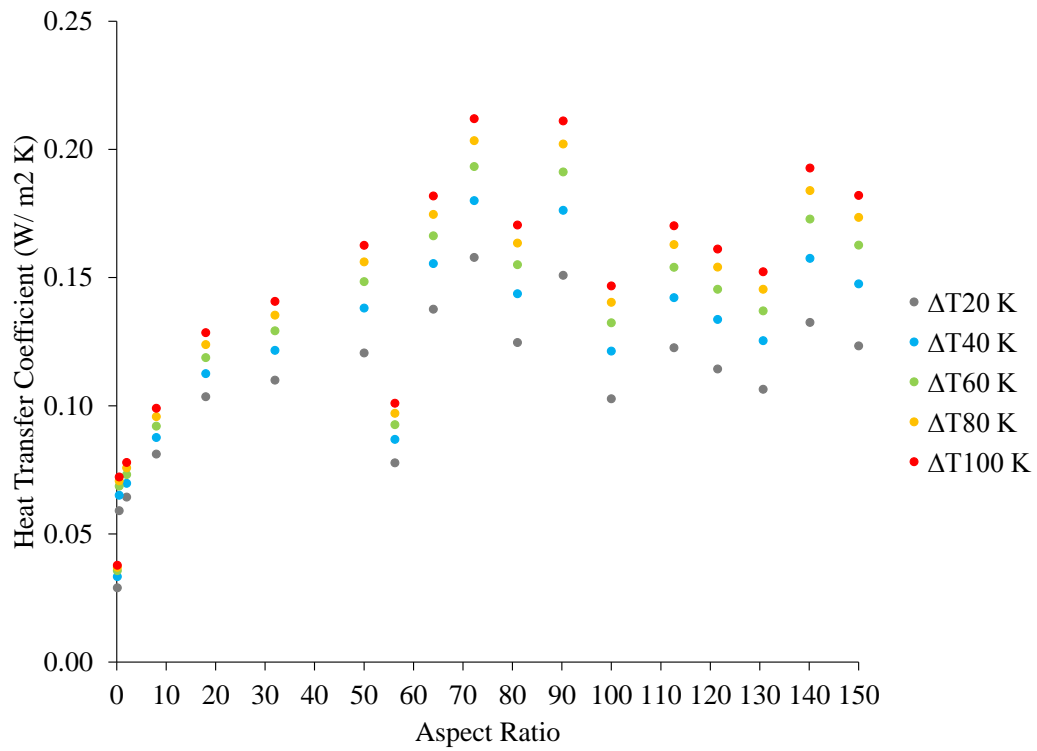

Figure 32: Variation of Heat Transfer Coefficient with Aspect Ratio for Fluid 3

#### 4.5 Development of Correlations for Nusselt Number

The section of this project is to develop correlations for Nusselt number based on simulation results obtained. Correlations developed are then used to calculate Nusselt number values and compared against actual Nusselt number values to test accuracy and reliability of the correlations developed. In this project, the Nusselt number correlations are developed as a function of aspect ratio and Rayleigh number. The correlations proposed for fluid 1, fluid 2 and fluid 3 with varying aspect ratios ( $0.125 \leq AR \leq 150$ ) and temperature gradients ( $20 \text{ K} \leq \Delta T \leq 100 \text{ K}$ ) are given in Eq (21), Eq (22) and Eq (23) respectively. Overall, the average deviation exhibited by the developed Nusselt number correlation of fluid 1, fluid 2 and fluid 3 is 11.48%, 23.74% and 12.63% respectively. Deviations of these correlations probably due to uncontrolled radiation happened inside the enclosures. Performance of correlation for fluid 1, fluid 2 and fluid 3 are shown in Figure 35 - 35. R-squared values that indicates regression line given by each of the correlations are displayed in the plots as well.

$$\text{Fluid 1} : Nu = 1.46 \times 10^{-5} (AR)^{0.19} (\ln Ra)^{3.228} \quad (21)$$

$$\text{Fluid 2} : Nu = 1.02 \times 10^{-6} (AR)^{-0.0907} (\ln Ra)^{3.337} \quad (22)$$

$$\text{Fluid 3} : Nu = 7.57 \times 10^{-6} (AR)^{0.0256} (\ln Ra)^{3.114} \quad (23)$$

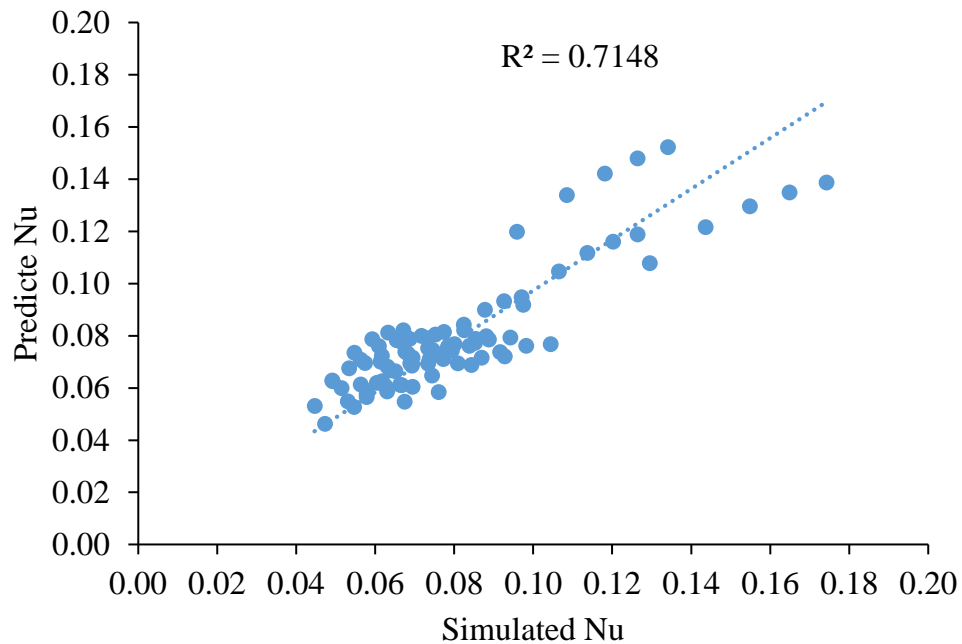

Figure 33: Parity plot for predicted Nusselt number by correlation of fluid 1

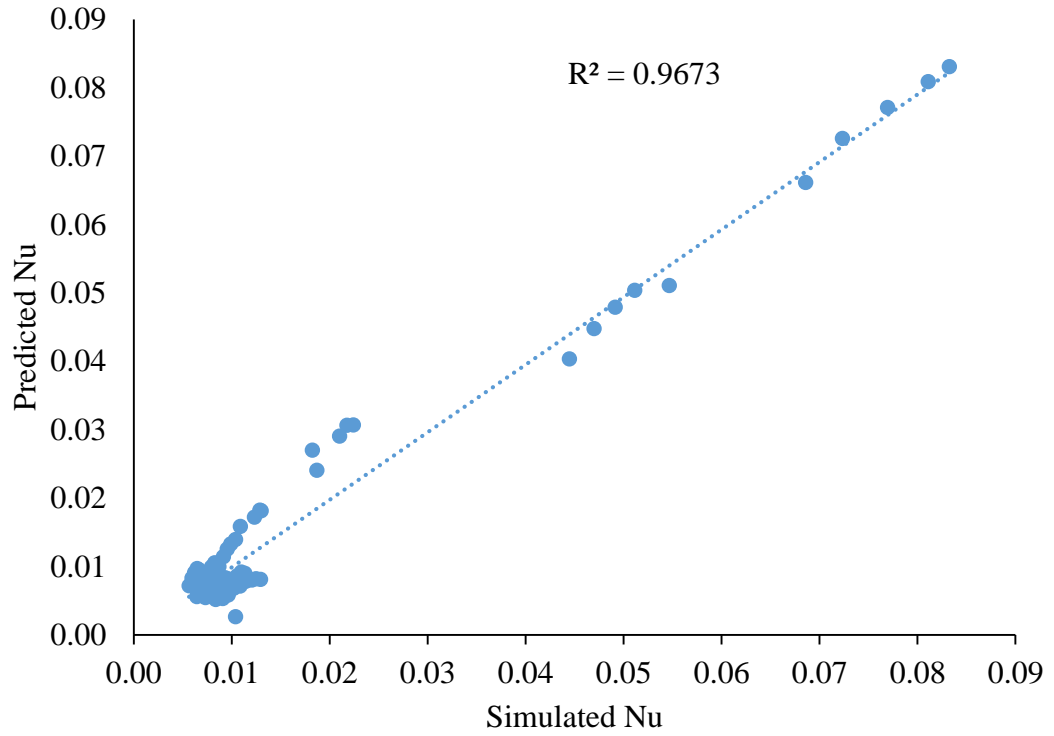

Figure 34: Parity plot for predicted Nusselt number by correlation of fluid 2

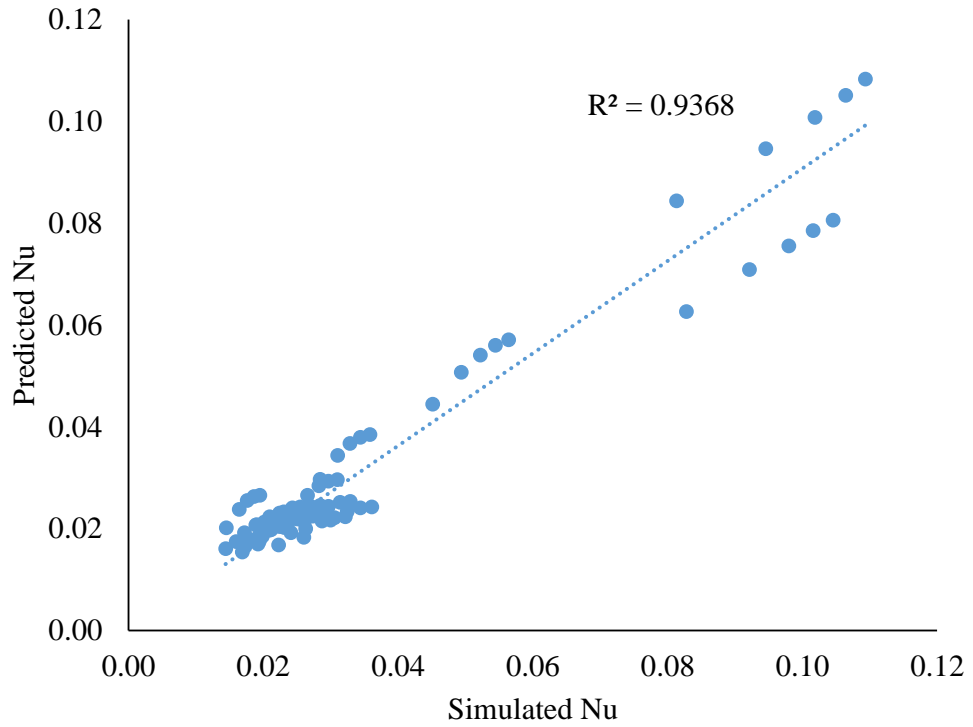

Figure 35: Parity plot for predicted Nusselt number by correlation of fluid 3

## **CHAPTER 5**

### **CONCLUSION AND RECOMMENDATION**

#### **5.1 Conclusion**

After performing 3-dimensional CFD simulation on natural convection heat transfer and fluid flow in enclosure with varying aspect ratios ( $0.125 \leq AR \leq 150$ ) in ANSYS 15.0 using fluid 1, fluid 2 and fluid 3 at temperature gradient from 20 K to 100 K, we can concluded that aspect ratios of enclosures is practically important in predicting optimum design for a desired product to minimize heat loss, minimize condensation of fluid inside the cavity and improve the heat transfer. Based on the results, it is observed that increase in aspect ratio will causes an increase in average static temperature due to greater heat transfer surface area (hot wall) and enhanced in heat transfer performance (conductive and convective) is expected. Besides, it is found that fluid 2 gives the best convective heat transfer performance due to highest heat transfer coefficient possessed. Furthermore, low aspect ratio enclosure with multicellular fluid flow in fluid 1 is suggested to give better convective heat transfer performance. Increase with temperature difference between hot and cold wall will further enhanced the convective heat transfer performance. High aspect ratio enclosures are found to be conductive dominated. Three correlations for Nusselt has been developed based on the simulation results obtained. Parity plots are also plotted in order to determine performance of the developed correlations. Correlation for fluid 2 gives the highest accuracy with R-squared value of 0.9673 followed by fluid 3 and fluid 1, each with R-squared value of 0.9368 and 0.7148 respectively. As a conclusion, all the simulations for this project had completed and all the objectives has been achieved.

#### **5.2 Recommendation**

For future development, it is recommended to study natural convection heat transfer and fluid flow using different fluids for example fluids with metallic properties and inert gases. Effects of 3D enclosures with different shapes on natural convection heat transfer is also worth to study as it has wide engineering applications in the industry. Limited knowledge on heat transfer characteristics of fluids in tilted enclosures makes it significant if the study

is to be carried out. Transient state simulations with temperature difference changing with respect to time (linear, sinusoidal, exponential and etc.) are also recommended to be studied in the future. Besides experimental study and numerical simulations on current topic using different simulation tools is also suggested in order to further improve the work to obtain better results.

## REFERENCES

- [1] I. Catton. "Natural convection in enclosures," *Proceedings of Sixth International Heat Transfer Conference, Toronto, Canada*, Vol 6, pp. 13-31, 1978.
- [2] B.M. Berkovsky and V.K. Polevikov, "Numerical study of problems on high-intensive free convection," *In Heat Transfer and Turbulent buoyancy Convection*, ed. D.B. Spalding and N. Afgan, pp. 443 – 445, 1977.
- [3] R.K. MacGregor and A.P. Emery, "Free convection through vertical plane layers: Moderate and high prandtl number fluids," *Journal Heat Transfer*, Vol. 91, pp.391, 1969.
- [4] J. Patterson and J. Imberger, "Unsteady natural convection in rectangular cavity," *Journal of Fluid Mechanics*, Vol. 100, pp. 65-86, 1980.
- [5] S. M. Elsherbiny, G. D. Raithby, and K. G. Hollands, "Heat transfer by natural convection across vertical and inclined fluid 1 layers," *ASME Journal of Heat Transfer*, Vol. 104, pp. 96-102, 1982.
- [6] A. Bejan, *Convection heat transfer*, 2<sup>nd</sup>. ed., New York: John Wiley & Sons Inc, 1995.
- [7] G. D. Raithby and G.T. Hollands, "Natural convection in handbook of heat transfer," *W. M. Rosenhow, J. P. Hartnett, Y. I.Cho, eds.*, pp. 4.1-4.99, 1998.
- [8] A. K. Shati, S. G. Blakey and S. B. Beck , "The effect of surface roughness and emissivity on radiator output," *Energy and Buildings*, Vol. 43, pp. 400-406, 2011.
- [9] Y. Kamotani, S. Ostrach, and L. W. Wang, "Experiments on natural convection heat transfer in low aspect ratio enclosures," *AIAA Journal*, vol. 21, pp. 290-294, 1983.
- [10] W. S. Lin and W. Akin, "Natural convection cooling of rectangular and cylindrical containers," *International Journal of Heat and Fluid Flow*, Vol. 22, pp. 72 – 81, 2011.

- [11] Z. T. Yu, L. W. Fan, Y. C. Hu and K. F. Cen, "Prandtl number dependence of laminar natural convection heat transfer in a horizontal cylindrical enclosure with an inner coaxial triangular cylinder," *International Journal of Heat and Mass Transfer*, Vol. 53, pp. 1333-1340, 2010.
- [12] O. Y. Taha, "Numerical Simulation of transient laminar natural convection of high prandtl number fluid in cubical cavity," University Rovira i Virgili, Spain, 2006.
- [13] R. Nasrin, S. Parvin and M. A. Alim, "Effect of Prandtl number on free convection in a solar collector filled with nanofluid," *5th BSME International Conference on Thermal Engineering*, Vol. 56, pp. 54-62, 2013.
- [14] R.R. Nourgaliev, T.N. Dinh, and B.R. Sehgal, "Effect of fluid Prandtl number on heat transfer characteristics in internally heated liquid pools with Rayleigh numbers up to 1012," *Nuclear Engineering Design*, Vol. 169, pp. 165-184, 1997.
- [15] T. Pessa and S. Piva, "Laminar natural convection in a square cavity: Low Prandtl numbers and large density differences," *International Journal of Heat and Mass Transfer*, Vol. 52, pp.1036-1043, 2009.
- [16] J. R. Lee and I. S. Park, "Numerical analysis for prandtl number dependency on natural convection in an enclosure having a vertical thermal gradient with a square insulator inside," *Nuclear Engineering And Technology*, vol. 44, 2012.
- [17] A. Ganguli, A. Pandit and J. Joshi, "CFD simulation of heat transfer in a two-dimensional vertical enclosure," *Chemical Engineering Research And Design*, vol. 87, pp. 711-727, 2009.
- [18] C. Aswatha, J. G. Gowda, S. N. Sridhara and K. N. Seetharamu, "Effect of different thermal boundary conditions at bottom wall on natural convection in cavities," *Journal of Engineering Science and Technology* , vol. 6, pp. 109-130, 2011.
- [19] F. P. Incropera and D. P. Dewitt, *Fundamentals of Heat and Mass Transfer*. John Wiley & Sons, 2002.