

**Experimental Study on Electrical Power Generation from 1 kW Engine Using
Simulated Biogas Fuel**

by

Nur Aliana Binti Ismail

16982

Dissertation submitted in partial fulfillment of

the requirements for the

Bachelor of Engineering (Hons)

(Mechanical)

JANUARY 2015

Universiti Teknologi PETRONAS

Bandar Seri Iskandar

32610 Tronoh

Perak Darul Ridzuan.

CERTIFICATION OF APPROVAL

**Experimental Study on Electrical Power Generation from 1 kW Engine Using
Simulated Biogas Fuel**

by

Nur Aliana binti Ismail

16982

A project dissertation submitted to the
Mechanical Engineering Programme
Universiti Teknologi PETRONAS
in partial fulfillment of the requirement for the
BACHELOR OF ENGINEERING (Hons)
(MECHANICAL)

Approved by,

(Ir. Dr. Suhaimi Bin Hassan)

UNIVERSITI TEKNOLOGI PETRONAS
TRONOH, PERAK

May 2015

CERTIFICATION OF ORIGINALITY

This is to certify that I am responsible for the work submitted in this project, that original work is my own except as specify in the references and acknowledgements, and that the original work contained herein have not been undertaken or done by unspecified sources or persons.

NUR ALIANA BINTI ISMAIL

ABSTRACT

This research paper presented a biogas as a fuel for small 1 kW power engine. The simulated biogas fuel was tested on type of spark ignition engine of generator and it examined the engine performance at the constant engine speed under load transients. The generator was connected to load bank and it was functioned to generate a comparable result from the laboratory experiments by using gasoline, liquefied petroleum gas (LPG) and natural gas as fuel in the engine to be evaluated with simulated biogas. Based on study conducted, on more general proportion, 60% of methane (CH_4) and 40% of carbon dioxide (CO_2) in the simulated biogas was used. The results obtained from testing the engine have been found to be satisfactory. As the calculations on electric power generation, fuel flow rate, specific fuel consumption, (sfc) and engine efficiency have been made, the results showed that the performance of engine and exhaust emissions fuelled with gasoline would be a baseline for this project. It also showed that maximum specific fuel consumption for LPG and natural gas was decreased by 10% and 23.4% respectively when compared to gasoline and it is proven that the simulated biogas has consumed more fuel (1254.83 kg/kWh) with only reach up to 780 W. The power reduction of engine using simulated biogas was about 22% as compared to gasoline. In term of engine efficiency, gasoline, LPG, natural gas have generated 21%, 20.7%, 20.4% respectively while simulated biogas generated only 0.16% of engine efficiency.

ACKNOWLEDGEMENTS

First and foremost, I would like to express my deepest gratitude to Allah SWT for His guidance and mercy for the completion and success of my final year project.

A huge gratitude to my supervisor, Ir. Dr, Suhaimi bin Hassan for his willingness to spend his time to respond regarding this report. It has been a great privilege to be under his supervision.

Recognition to the coordinator for Final Year Project of Mechanical Engineering department, Dr Tamiru Alemu Lemma for all his contribution, monitoring and discussions that contribute to the success of this project. Without his support and encouragement, I could not have gained the experience and knowledge during this project period.

I like to take the opportunity to thank Mr. M Faizairi B M Nor for his advices and encouragement to further improve the quality of this project.

Furthermore, I owe my profound gratitude to the postgraduate student and technician team for their constant assistance. This amazing team involved of individuals with amazing knowledge and dedicated to share their knowledge with me.

My appreciations go to Universiti Teknologi PETRONAS for being able to complete this final year project successfully. This final year project has given me vast amount of experience in working on a research project. Lastly, a deep appreciation to my family for giving me full support to complete this final year project.

TABLE OF CONTENTS

CHAPTER 1 INTRODUCTION	1
1.1 Background Study	1
1.2 Problem Statement	2
1.3 Objectives.....	2
1.4 Scope of study.....	2
CHAPTER 2 LITERATURE REVIEW	4
2.1 Current Energy Scenario and Sustainability Energy in Malaysia	4
2.2 Overview of Biogas.....	4
2.3 Internal Combustion Engine	5
2.4 Engine Performance Parameters and Governing Equations	6
2.5 Summary of Literature Study Reviewed.....	10
CHAPTER 3 METHODOLOGY	11
3.1 Experimental Setup	11
3.1.1 Engine Specification	12
3.1.2 Instrumentation	13
3.2 Procedure Running the Generator with Gasoline (Petrol)	16
3.3 Procedure Running the Generator with Liquefied Petroleum Gas (LPG) ..	18
3.4 Procedure Running the Generator with Natural Gas.....	20
3.5 Procedure Running the Generator with Simulated Biogas	22
3.5.1 Calibration Percentage of CH ₄ and CO ₂ Composition.....	22
3.5.2 Collection of Gas over Water.....	22
3.5.3 Detailed Procedure	25
3.6 Progress Work Flow.....	28
3.7 Gantt Chart and Key Milestones	29
CHAPTER 4 RESULTS AND DISCUSSIONS.....	30
4.1 Introduction.....	30
4.2 Engine Performance	31
4.2.1 Variation of Electric Power Calculation with Bulb	31
4.2.2 Variation of Fuel Flow Rate with Load	32

4.2.3 Variation of Specific Fuel Consumption with Load	36
4.2.4 Variation of Engine Efficiency with Load	39
4.2.5 Variations of Temperature with Load	40
4.2.8 Variation of Exhaust Emissions with Load.....	41
CHAPTER 5 CONCLUSION AND RECOMMENDATION.....	49
CHAPTER 6 REFERENCES	51
CHAPTER 7 APPENDIX.....	54

LIST OF FIGURES

Figure 3.1: USR EV10i Portable Inverter Generator	13
Figure 3.2: Electrical Loads	13
Figure 3.3: Ammeter	14
Figure 3.4: Automotive Exhaust Gas Analyzer (AUTOplus 5-2).....	14
Figure 3.5: Portable Handheld Data Logger OM-DAQPRO-5300.....	16
Figure 3.6: Experiment Set-up for Running the Generator with Gasoline	17
Figure 3.7: Schematic Drawing for Running the Generator with Gasoline	17
Figure 3.8: Experiment Set-up for Running the Generator with LPG	19
Figure 3.9: Schematic Drawing for Running the Generator LPG.....	20
Figure 3.10: Experiment Set-up for Running the Generator with Natural Gas	21
Figure 3.11: Schematic Drawing for Running the Generator with Natural Gas	21
Figure 3.12: Simulated Biogas Flowrate Chart from Water Displacement Method. 23	
Figure 3.13: Experiment Set-up for Running the Generator with Simulated Biogas 26	
Figure 3.14: Schematic Drawing for Running the Generator with Simulated Biogas	27
Figure 3.15: Progress Work Flow	28
Figure 4.1: Variation of Amount of Current with Bulb	31
Figure 4.2: Variation of Power Generated, kW with Bulb	32
Figure 4.3: Variation of Fuel Flow Rate with Load.....	36
Figure 4.4: Variation of Specific Fuel Consumption with Load.....	37
Figure 4.5: Variations of Engine Efficiency with Load.....	39
Figure 4.6: Variation of Temperature with Load	40
Figure 4.7: Percentage of Carbon Dioxide in Exhaust Emission.....	43
Figure 4.8: Percentage of Carbon Monoxide in Exhaust Emission	44
Figure 4.9: Percentage of Oxygen in Exhaust Emission.....	45
Figure 4.10: Percentage of Hydrocarbon in Exhaust Emission	46
Figure 4.11: Percentage of Nitrogen Oxide in Exhaust Emission	47
Figure 4.12: Equivalence Ratio.....	48

LIST OF TABLES

Table 1.1: Total World's Primary Energy Consumption in 2009 (EIA,2010)	2
Table 2.1: Biogas Composition from Several Researchers' Studies.....	5
Table 2.4: Stoichiometric Ratio and Equivalence Ratio	9
Table 3.1: Fuel Gas Properties	11
Table 3.2: Engine Specification	12
Table 3.3: Specification of Sirius Multigas Detector.....	15
Table 3.4: Summary of Calculation of Simulated Biogas Mixture Density	24
Table 3.5: Project Gantt Chart	29
Table 4.1: Data from Experimental Work.....	30
Table 4.2: Calculation for Electric Power Generation	32
Table 4.3: Amount of Gasoline Consumed For Average and Maximum Load Modes from the Weight Differences Value of the Gasoline Fuelled Generator.....	33
Table 4.4: Amount of LPG Consumed For Average and Maximum Load Modes from the Weight Differences Value of the LPG Cylinder Tank	33
Table 4.5: Amount of Natural Gas Consumed For Average and Maximum Load Modes from the Flowmeter Value of the Natural Gas Line.....	34
Table 4.6: Amount of Simulated Biogas Consumed For Average and Maximum Load Modes from the Flowmeter Value of the Simulated Biogas Line	35
Table 4.17: Variation of Temperature with Load	40
Table 4.8: Components Detected in Exhaust Emissions with Gasoline	41
Table 4.9: Components Detected in Exhaust Emissions with LPG	42
Table 4.10: Components Detected in Exhaust Emissions with Natural Gas	42
Table 4.11: Components Detected in Exhaust Emissions with Simulated Biogas ...	43

LIST OF ABBREVIATIONS

AC	Alternating current
AFR	Air flow ratio
b_p	Brake power
CH ₄	Methane
CI	Compression ignition
CO	Carbon monoxide
CO ₂	Carbon dioxide
CV	Calorific value
DC	Direct current
EIA	Energy Information Administration
GHG	Greenhouse gases
H ₂ O	Water
H ₂ S	Hydrogen sulphide
H ₂ SO ₄	Sulphurous acid
ICE	Internal combustion engine
λ	Stoichiometric ratio
LEL	Lower explosive limit
LPG	Liquefied petroleum gas
LPM	Litre per minute
O ₂	Oxygen
P	Power
PTM	Pusat Tenaga Malaysia
sfc	Specific fuel consumption
SI	Spark ignition
SO ₂	Sulphur dioxide
SO ₃	Sulfite
STP	Standard temperature and pressure
UEL	Upper explosive limit
UTP	Universiti Teknologi PETRONAS
VOC	Volatile organic compounds
ρ_a	Density of air
\dot{m}_f	Mass flow rate of fuel

CHAPTER 1

INTRODUCTION

1.1 Background Study

Recent energy condition all over the world and the fact that most important resources of energy, such as crude oil, natural gas, coal and nuclear fuel are not renewable give consequence to other sources of energy, like hydro energy, solar energy, wind energy and biogas. These stated energy sources are all renewable, but biogas is predominantly important because of likelihood of use in internal combustion engines compared to others, which are the main power source for transport vehicles and also commonly used for powering of generators of electrical energy. This possibility of use is justified by biogas properties, which make it suitable for internal combustion engines, ICE. (Mihic, 2004).

According to the cycle of operation, ICE is classified into two categories which are spark ignition engine and compression ignition engine. One type of ICE is chosen that is spark ignition engine or known as gasoline engine for this project. Basically, the classification of engine is based on type of fuel used. Gasoline is one of volatile liquids whereas biogas and LPG are categorized as gaseous fuels. It is said that engine using gaseous fuels has similar working principle as the engine using volatile liquids (Ganesan, 2004).

Table 1.1 shows the Total World's Primary Energy Consumption in 2009, retrieved from Energy Information Administration, EIA. This table summarized the percentages for each non renewable energy and renewable energy. For renewable energy, biomass material achieved the highest percentage among all of the total world's major energy consumption where biogas is one form of biomass material.

Table 1.1: Total World's Primary Energy Consumption in 2009 (EIA, 2010)

Type of Energy	Fuel/Process	Percentage (%)
Non-Renewable Energy	Petroleum Oil	37
	Natural Gas	24
	Coal	23
	Nuclear Power	8.0
Renewable Energy	Biomass Material	4.3
	Geothermal and Hydropower	3.1
	Solar and Wind	0.6

1.2 Problem Statement

It is not new to use an alternative gaseous fuel for internal combustion engines (ICE). One of the gases is biogas from landfill that has been widely used to fuel the ICE. However, on the whole of the engine performance using biogas is slightly reduced as compared to conventional fuel such as gasoline and diesel. Therefore, investigation in terms of experimental study is required in order to understand and to determine the main reason of power reduction when biogas is used as a fuel in ICE.

1.3 Objectives

The objectives of this study are:

- To study the use of alternative gaseous fuel for engine.
- To investigate the performance of biogas as fuel for internal combustion engine.
- To compare the overall performance of biogas engine with conventional fuel.

1.4 Scope of study

The scopes of study involve internal combustion engine specifically on spark ignition besides using different sources of fuels to conduct the experimental work in the laboratory which the conventional fuel are the gasoline or known as petrol, LPG, natural

gas and the alternative resource which is simulated biogas fuel at 60% composition of CH₄ and 40% composition of CO₂. The performance of simulated biogas fuel will be analyzed as to compare with the conventional fuels mentioned using 1 kW portable inverter power generator. Besides, it is to study the conversion from gasoline, LPG as well as natural gas to biogas fuel to generate electrical energy. It will then extend the study to how biogas usage would reduce the engine efficiency. The project will be carried out in Universiti Teknologi PETRONAS (UTP).

The expected progress and timeline are deliberated in the subsequent chapters as demonstrate in the Gantt chart and project key milestone respectively.

CHAPTER 2

LITERATURE REVIEW

2.1 Current Energy Scenario and Sustainability Energy in Malaysia

The primary energy source such as crude oil, natural gas and other conventional fuels are inadequate resources formed by geological processes throughout solar energy buildup into the earth over millions of years. Renewable energy is generated from sustainable resources such as wind, solar, hydro, geothermal and biomass (Shekarchian et al., 2011). Furthermore, the fossil fuels will significantly contribute to the emission of greenhouse gases (GHG) from the combustion and raising the climate change issue. Thus, the new and renewable energies will become one of the main energy resources for the world. The conversion of biogas energy is presented as a solution to the large volume of waste produced, as it allows the reduction of the toxic potential of CH₄ emissions (Garcilasso et al., 2011). Other researchers supported the study by mentioning that CH₄ which is a strong GHG, is released into the atmosphere from manure in traditional manure storage and biogas can both decrease the leakage of CH₄ from manure and decrease the emissions of fossil carbon dioxide (Surata et al., 2014).

2.2 Overview of Biogas

In regards to environmental point of view, there is an urge in reducing the emission of pollutant substances in the atmosphere. According to Pusat Tenaga Malaysia (PTM) or known as Malaysia Energy Centre, biogas is among several renewable sources of energy that will be prioritized under the policy (Oh et al., 2010). The biogas is obtained by the means of anaerobic digestion where the fermentative process without oxygen (O₂) is take place. For this process to occur, the degradation of organic matters in landfills (waste), Effluent Treatment Plants (sewage) and animal waste happen (Garcilasso et al., 2011).

Research carried out on the anaerobic digestion of a variety of agricultural wastes indicates that there is a enormous variability in the composition of the biogas produced (Huang and Crookes 1998). On the contrary, Surata et al. (2014) stated that biogas quality varies among the state make it difficult to upgrading in to the standard state for fueled the engine. Hence, this various composition make complicated for the user in setting the engine for example to run the electric generator. Referring to Table 2.1, it shows biogas composition reported from several researchers in their technical reports. Different researchers will report with various compositions as a study by Surata et al. (2014), proved that the concentrations of the biogas composition are dependent on the substrate composition from which the gas was produced.

Table 2.1: Biogas Composition from Several Researchers' Studies

No	References	CH ₄ Percentage	CO ₂ Percentage	Other compositions Percentages
1	(Osario and Torres 2009)	60-70 %	30-40 %	N ₂ (<1%) H ₂ S (10-2000 ppm)
2	(Porpatham et al., 2008)	60 %	30%	CO (0.18%) H ₂ (0.18%)
3	(Mihic, 2004)	50-70%	30%	H ₂ (2%)
4	(Huang and Crookes 1998)	50-70%	25-50%	H ₂ (1-5%) N ₂ (0.3-3%)
5	(Garcilasso et al., 2011)	60%	35%	N ₂ , H ₂ , NH ₃ , H ₂ SO ₄ , CO, and volatile amines

2.3 Internal Combustion Engine

According to Ganesan (2004), internal combustion engines are devices that create work using the products of combustion as the working fluid instead of as a heat transfer medium. This combustion takes place within the engine. There are two types of engine which are spark ignition (SI) and compression ignition (CI). According to Pundir

(2010), SI engine uses premixed, homogeneous air-fuel mixture, which is ignited by electric discharge from a spark plug whereas CI engine operates on heterogeneous air-fuel mixture created by injection of fuel in the cylinder. Ganesan (2004) also cited, because of high compression in CI engine, it generates high air temperature and consequently self ignition will occur.

In regard with biogas as fuel, there is a comparison between spark and compression ignition engine trends. The spark-ignition engine operation with biogas containing significant fractions of inert gases such CO_2 and N_2 exhibit penalties of performance compared with natural gas or gasoline (Crookes, 2006). However, he mentioned that by raising the compression ratio, performance will increase though it is likely the emissions of NO_x will increase as well. Yet, compression-ignition engine operation will lead to higher specific fuel consumption when compared with diesel fuel and thermal efficiency is comparable. From these statements above, the author can conclude that the specific fuel consumption is comparable with these two types of engine.

However this study focuses on SI engine as to power the portable inverter generator, it works on gasoline fuel to start before convert to biogas fuel. In details, the operation cycle for SI engine is working on Otto cycle or constant volume heat addition cycle (Ganesan, 2004).

2.4 Engine Performance Parameters and Governing Equations

Usually, the engine test results obtained in terms of power output, specific gas consumption and thermal efficiency (Surata et al., 2014). Various high efficiency strategies for power generation using biogas and the results were compared with gasoline, LPG and natural gas operation at same electrical power. Several researchers have studied on the effect on CO_2 in biogas-fuelled engines. Porpatham et al. (2008) found that the reduction in concentration of CO_2 leads to higher efficiency and power output in SI engine. On the other hand, in research paper written by Surata et al. (2014) have mentioned that the biogas should be upgraded to zero level of water (H_2O) content and level of zero hydrogen sulfide (H_2S) to avoid the corrosion on the combustion

chamber when there is an increasing in acidity of the lubricant. Razbani et al. (2011) added there are acids leads to engine parts corrosion as an impact of biogas contaminants to ICE. H_2S will react and forms sulfur dioxide (SO_2) and H_2O in order to form H_2SO_3 , the sulphurous acid. SO_2 could react with O_2 to form sulfite (SO_3) and with H_2O to H_2SO_4 , the sulfuric acid.

Additionally, in regard to increase efficiency of biogas fuelled generator, Surata et al. (2014) stated that the LPG was added to the mixture up to 80% biogas and 20% LPG. Moreover, in their study, the engine test results enriched biogas containing 95% CH_4 has showed that engine performance is nearly alike to that compressed natural gas which proved that biogas can be used as fuel for natural gas vehicles that indirectly verify that petrol and diesel can be replaced (Surata et al., 2014).

Engine performance depends on and is characterized by several parameters related to engine geometry and thermodynamics.

Brake thermal efficiency is the ratio of energy in the brake power, b_p , to the input fuel energy. Calorific value (CV) of a fuel is the thermal energy released per unit quantity of the fuel when the fuel is burned entirely and the products of combustion are cooled back to initial temperature of the combustion mixture. In other word, it is the heating value and heat of combustion (Ganesan, 2004). As electric power finally produced was of the main concern, overall efficiency was defined as the ratio of output electric power consumed by the load to the heat input of fuel (Ehsan and Naznin, 2004). Thus, it is understood that definition of the parameter used is important to determine the specific term used for the concerned governing equation.

Based on Ganesan (2004), the governing equations related are as below:

Specific fuel consumption, sfc is commonly expressed in expressions of specific fuel consumption in kilograms of fuel per kilowatt-hour, which is a parameter that reflects

how good the engine performance is. However, it is inversely proportional to the engine efficiency of the engine.

$$\text{Specific Fuel Consumption, sfc} = \frac{\dot{m}_f}{P} \quad (1)$$

Where,

\dot{m}_f = Mass flow rate of fuel

P = Power

For this research study, the appropriate term associated with the electric power generated that is relevant to brake thermal efficiency is energy efficiency as the method implied.

$$\text{Brake thermal efficiency, } \eta_{\text{bth}} = \frac{b_p}{\dot{m}_f \times CV} \quad (2)$$

Where,

b_p = Brake power

\dot{m}_f = Mass flow rate of fuel

CV = Calorific value of fuel

Stoichiometric ratio, λ is the value of Lambda that gives an indication of the burning efficiency of the engine. The value depends on the composition of the fuel, the air that is used for the combustion and on the combustion products as found in the exhaust gases.

A basic formula, taking into account:

- Components of the fuel: carbon, hydrogen, oxygen and water content;
- Water content of the air;
- Components of the exhaust gases: carbon dioxide, carbon monoxide, hydrocarbons and nitrogen oxide; Brettschneider (1979).

A simplified formula, derived from the basic formula, and based upon the assumption that the water content of the fuel and air and the NOx content in the exhaust

gases are negligible, allows the computation of λ when certain components of the exhaust are measured.

$$\lambda = \frac{\text{CO}_2 + (\text{CO}/2) + \text{O}_2 + [\text{HCV}/4 \times \{3.5 / (3.5 + \text{CO}/\text{CO}_2)\} - \text{OCV}/2] \times (\text{CO}_2 + \text{CO})}{(1 + \text{HCV}/4 - \text{OCV}/2) \times \{(\text{CO}_2 + \text{CO}) + (\text{K1} \times \text{HC})\}} \quad (3)$$

Where:

CO = Carbon monoxide % volume measured.

CO₂ = Carbon dioxide % volume measured.

HC = Hydrocarbon ppm volume measured.

O₂ = Oxygen % volume measured.

K1 = Conversion factor for HC is expressed in ppm vol n-hexane (C₆H₁₄) equivalent. Its value in this formula is 6.10⁻⁴

H_{cv} = Atomic ratio hydrogen to carbon in the fuel. Nominal value is 1.7261

O_{cv} = Atomic ratio oxygen to carbon in the fuel. Nominal value is 0.0176

$$\text{Equivalence Ratio, } \Phi = \frac{1}{\lambda} \quad (4)$$

Table 2.4 indicates the relationship between stoichiometric ratio and equivalence ratio with respect to type of mixture.

Table 2.4: Stoichiometric Ratio and Equivalence Ratio

Type of mixture		
Rich	Stoichiometric	Lean
$\lambda < 1$	$\lambda = 1$	$\lambda > 1$
$\Phi > 1$	$\Phi = 1$	$\Phi < 1$

2.5 Summary of Literature Study Reviewed

The conversion of biogas energy is presented as a solution to the large volume of waste produced, as it allows the reduction of the toxic potential of CH₄ emissions (Garcilasso et al., 2011). Biogas composition reported from several researchers in their technical reports. Different researchers will report with various compositions as a study by Surata et al. (2014). Hence, it can be summarized that on more general proportions are typically 60% of CH₄ and 40% of CO₂ in the biogas.

As for this research study conducted on spark ignition engine, Crookes (2006) has mentioned that the spark-ignition engine operation with biogas containing significant fractions of inert gases such CO₂ and N₂ exhibit penalties of performance compared with natural gas or gasoline. Meanwhile, there are several researchers have studied on the effect on CO₂ in biogas-fuelled engines. Porpatham et al. (2008) found that the reduction in concentration of CO₂ leads to higher efficiency and power output in SI engine. Hence, exhaust concentration of CO, CO₂, O₂, NO_x were also be analyzed.

CHAPTER 3

METHODOLOGY

This research methodology requires gathering relevant data from the experimental work conducted in order to analyze the requirements needed and arrive at more complete understanding and background of the project.

3.1 Experimental Setup

The experimental work was conducted to evaluate and examine the direct use of gasoline, LPG, natural gas and biogas in a small internal combustion engine in terms of the engine performance and exhaust emissions at different electrical load conditions. Table 3.1 shows typical properties of biogas compared to other gaseous fuels declared by Pundir, (2010) and Himabindu & Ravikrishna, (2014).

Table 3.1: Fuel Gas Properties

Property	Gasoline	LPG	Natural Gas	Simulated Biogas
Lower Heating Value at 1 atm and 15 °C (MJ/kg)	42.9	45.7	50.0	17.64
Density at 1 atm and 15 °C (kg/m ³)	750	2.26	0.7-0.9	1.43
Flame Speed (cm/s)	62	38.25	34	25
Stoichiometric A/F (kg of air/kg of fuel)	14.7	15.5	17.3	11
Leaner	15.0	2.15	5	7.5
Richer	13.0	9.6	15	14
Auto-Ignition Temperature (°C)	246 - 280	405-450	540	625

3.1.1 Engine Specification

Engine power evaluation was made by comparing the output capacity of the portable inverter generator of USR EV-10i driven by its engine of 4-stroke, OHV single cylinder. This engine has the compression ratio of 7.5:1. More details on its specification as in Table 3.2.

Table 3.2: Engine Specification

Engine Parameter	Specification		
Model	EV10i		
Engine	4-stroke, OHV single cylinder		
Displacement	49cc		
Compression	7.5:1		
Rated revolution	5500 r/min		
Fuel tank capacity	0.61 Gallon (2.3L)		
Fuel	Unleaded gasoline		
Oil capacity	0.07 Gallon (0.25L)		
Oil	SF or higher grad		
Rated AC frequency	50Hz	60Hz	60Hz
Rated AC voltage	230V	120V	240V
Rated AC current	4.3A	7.9A	3.96A
Rated AC output	900VA		
Surge AC output	1,000VA		
DC output	12V 8.3A		
Total harmonic distortion	≤3%		
Power factor cos	1		
Frequency stability	±0.1Hz		
Voltage stability	±4V		
Operating noise level	58dB(7m)		
Continuous operation at? Rated loads	6.5h		
Dry Weight	32lbs		



Figure 3.1: USR EV10i Portable Inverter Generator

3.1.2 Instrumentation

A) *Electrical loads*

The term load is used to mean the measured electric power produced by the electric generator. A bank of 10 light bulbs was used to vary the electric load produced by the generator. To increase the engine loading more bulbs were powered, to decrease the engine load fewer bulbs were powered. This “load bank” consisted of ten equal light bulbs of 100 watts each, wired in parallel, with every bulb a switch, to allow easy load variation for flexible testing. A picture of the load board is illustrated in Figure 3.2.



Figure 3.2: Electrical Loads

To measure the current of engine electric generator consumed, an ammeter is used. From the current data, calculation for electric power generated can be completed. An ammeter that is stuffed in the mounting board is illustrated in Figure 3.3.



Figure 3.3: Ammeter

B) Exhaust Emissions

Emission analysis was conducted with gas analyzer known as Automotive Exhaust Gas Analyzer (AUTOplus 5-2) as illustrated in Figure 3.4. The instrument's probe connecting with plastic tube was inserted into the exhaust flow for each tested fuel. Table 3.3 shows the specification of Automotive Exhaust Gas Analyzer.



Figure 3.4: Automotive Exhaust Gas Analyzer (AUTOplus 5-2)

Table 3.3: Specification of Automotive Exhaust Gas Analyzer

Parameter	Resolution	Accuracy	Range
Carbon Monoxide (Infrared)	0.01 %	+/- 5 % of reading +/- 0.06 % volume	0-10 % Over-range 20 %
Oxygen (fuel cell)	0.01 %	+/- 5 % of reading +/- 0.1 % volume	0-21 % Over-range 25 %
Hydrocarbon (Infrared)	1 ppm	+/- 5 % of reading +/- 12 ppm volume	0-5000 ppm Over-range: 10,000 ppm
Carbon Dioxide (Infrared))	0.1 %	+/- 5 % of reading +/- 0.5 % volume	0-16 % Over-range: 25%
Nitric Oxide (fuel cell)	1 ppm	0-1500ppm +/-5% or 25ppm;	0-1500ppm Over-range: 5000 ppm
Carbon Monoxide Corrected COK	0.01 %	Calculated	0-15%
Lambda	0.001		0.8 – 1.2
AFR (Petrol)	00.01		11.76 – 17.64
(LPG)			12.48 – 18.72
Sensor response T95		Nominal 20 seconds AUTOplus 4-2, 5-2.	
Warm up		Less than 2 minutes	
Pre-programmed Fuels Petrol/Gasoline, LPG Diesel and CNG.		Petrol/Gasoline, LPG Diesel and CNG.	
PC connection		Via RS 232 port	
Data-Logging		500 Tests	
Ambient Operating Range		+5°C to +45°C/10% to 90% RH non condensing	
Storage temperature		Minimum: 0°C Maximum: +50°C	
Battery Charger		Input: 100-240 V ~ 47-63 Hz Output: 12 V DC	
Analyser battery run time		>4 hours from full charge with the pump running	

C) Temperature

Qualitatively, the temperature of an engine is determined by the sensation of heat or cold felt by touching an object. Technically, temperature is a measure of the average kinetic energy of the particles in a sample of matter. This test is carried out using Portable Handheld Data Logger OM-DAQPRO-5300 model as it contains thermocouple temperature sensors as illustrated in Figure 3.5. The exhaust gas temperature is measured within one to three minutes before the 15 minutes test is ended. In this experimental study, temperature data is taken from the exhaust system to study the waste heat recovered from hot engine where variation of heat loss could be analyzed using different type of fuels.



Figure 3.5: Portable Handheld Data Logger OM-DAQPRO-5300

3.2 Procedure Running the Generator with Gasoline (Petrol)

The generator comprised of high voltage multiphase alternating current (AC) power generated by the alternator and the AC power is then converted to direct current (DC). Finally, the DC power is converted back to AC by the inverter unit. Experiment set-up is illustrated in Figure 3.6.

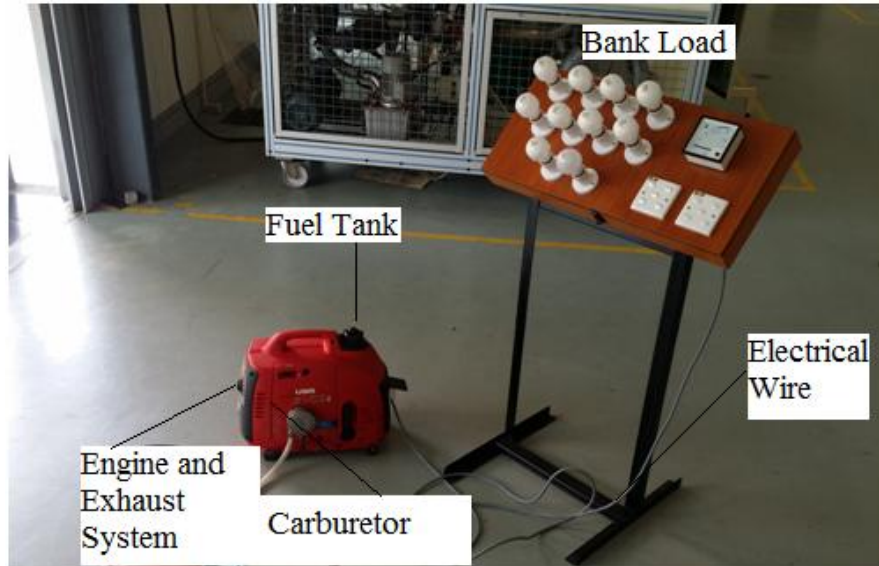

Figure 3.6: Experiment Set-up for Running the Generator with Gasoline

The schematic diagram for running the generator with gasoline is showed in Figure 3.7.

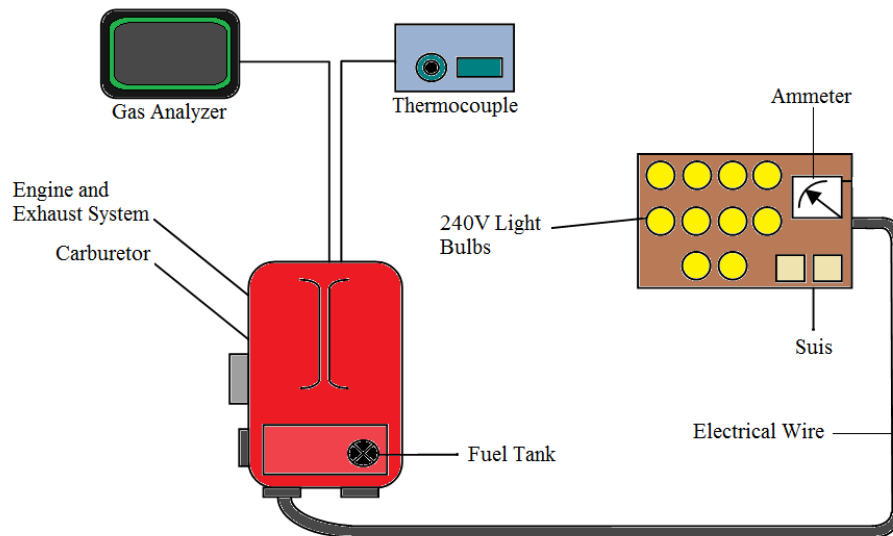

Figure 3.7: Schematic Drawing for Running the Generator with Gasoline

Before the experiment is started, the generator is weighed using TCS-Z Series Electronic Weighing Platform Scale. The generator fuelled with gasoline's weight is recorded. Start button is pushed and conversion to gasoline gate is ensured. The choke lever is turned on to close which is to the right side. Next, the grip starts and the rope are

pulled to the distance of 1.0 m in 0.4 seconds at full tilt. The pulling procedure will need to repeat for 3-5 times for the cold engine. After the engine is started, the choke lever is turned to the left side to open.

After the engine is started and the output indicator (green) came out, the appliance is plugged in. It is plugged to resistive electrical load bank. Digital stopwatch is set to measure 15 minutes time taken for the experiment. On the first test to find out amount of current consumed for each bulb, the bulb is switched on one by one and the current reading for each bulb is taken simultaneously using ammeter. On the second test, five bulbs are switched on for average load measurement and ten bulbs are switched on for maximum load measurement respectively. During the experiment is conducted, the observation on the variation of the temperature with load as well as exhaust emission are recorded. The generator is weighed again for each test.

3.3 Procedure Running the Generator with Liquefied Petroleum Gas (LPG)

LPG gas cylinder tank is weighed using TCS-Z Series Electronic Weighing Platform Scale and the measurement is recorded. LPG regulator is installed with three screws on the door to the plane window. The LPG trachea and regulating valve are fixed to make sure the various interfaces are locked on top of the LPG gas cylinder tank. On the front panel of the generator, the start switch is turned on. Conversion to brake rotation to gasoline gate is made. Valve on the LPG cylinder is opened. In order to start the engine, simultaneously the choke lever is pushed to the right side to close and the engine is started by pulling the grip starts and the rope to the distance of 1.0 m in 0.4 seconds at full tilt. Starter grip is pulled to operate the recoil starter to crank the engine.

Once the engine is started, the choke lever is turn to the left side to open and brake rotation to LPG gate is converted. Two minutes is estimated for the conversion of the engine to completely finish up the small quantity of gasoline used when it had switched to gasoline gate in the first place. At the time being, the knob on the LPG regulator is well-controlled to achieve stable operating condition at average and maximum load

setting respectively. In effect, it is also to reduce the vibration hold on the engine as the mixture of LPG gas with low amount of gasoline left will contribute the shaking of the engine. Digital stopwatch is used to measure the time taken of 15 minutes for each test conducted for average and maximum load measurement. As the output indicator (green) came out, the appliance is plugged in. After that, LPG gas cylinder tank is weighed again for each test. Experiment set-up is illustrated in Figure 3.8.

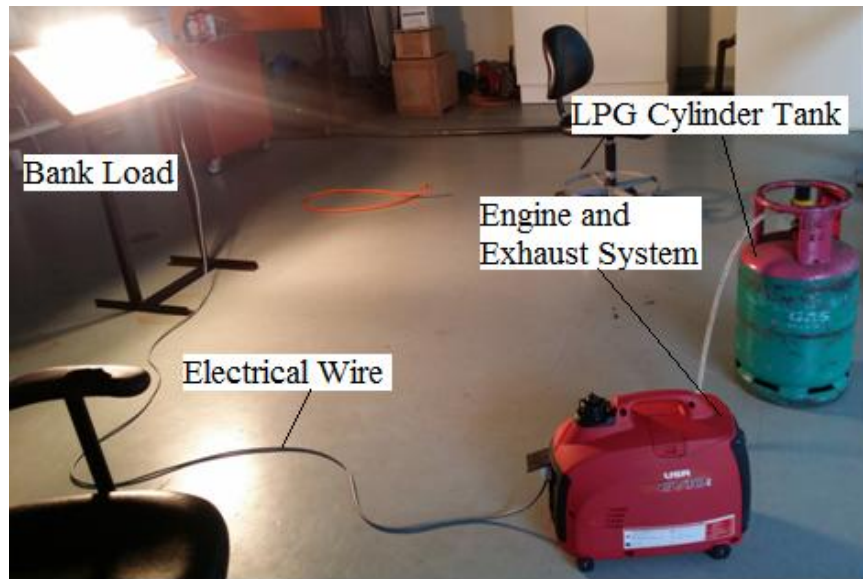

Figure 3.8: Experiment Set-up for Running the Generator with LPG

The schematic diagram for running the generator with LPG is shown in Figure 3.9.

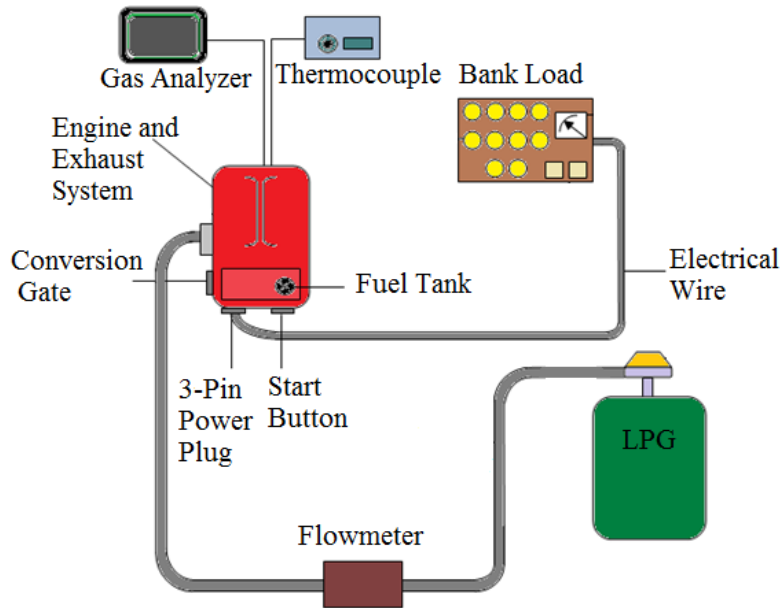

Figure 3.9: Schematic Drawing for Running the Generator LPG

3.4 Procedure Running the Generator with Natural Gas

Natural gas consists of 100% CH_4 . Single stage regulator is installed on the natural gas's inlet. The regulator is fastened to the cylinder and the inlet nut is tightened securely. The regulator is closed by turning the adjusting knob to the full counterclockwise position. The regulator must be closed before opening the cylinder valve. The adjusting knob is turned clockwise and the required use pressure is established by referring to the low-pressure gauge. High pressure hose is connected to the other side of regulator and connecting it to flow meter before joining to the generator. The subsequently experiment setup is the same as running the generator with LPG to turn on the start switch. Amount of fuel consumed to support the applied load was recorded using flowmeter. Experiment set-up is illustrated in Figure 3.10.

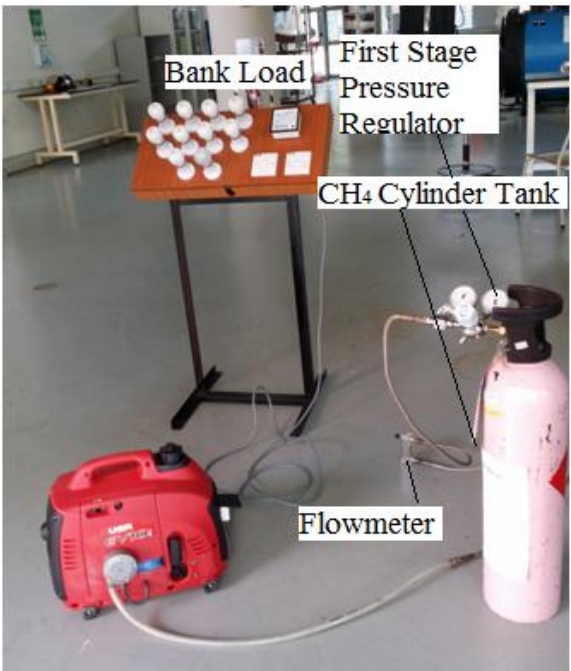

Figure 3.10: Experiment Set-up for Running the Generator with Natural Gas

The schematic diagram for running the generator with natural gas is shown in Figure 3.11.

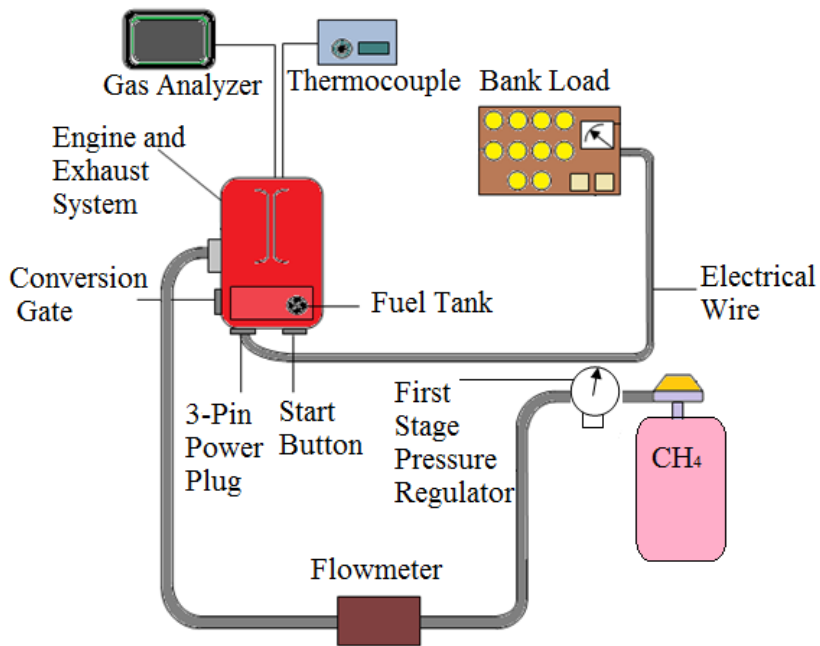

Figure 3.11: Schematic Drawing for Running the Generator with Natural Gas

3.5 Procedure Running the Generator with Simulated Biogas

A system of feeding biogas into small spark ignition engine driving generator has designed. Although the engine was designed for running on gasoline, LPG and natural gas, it was adapted to run on a supply of a range of synthetically produced biogas during this study. It is desired to run the engine on biogas with minimum modification to the hardware and retaining the capability of switching back to its gasoline fueling system easily.

3.5.1 Calibration Percentage of CH₄ and CO₂ Composition

To simulate the biogas, a proportional synthetic mixture of line supply of natural gas, CH₄ and CO₂ cylinder is made. The natural gas supply contained about 99.5% CH₄. Calibration percentage on CH₄ and CO₂ must first be made to determine 60% composition of CH₄ and 40% composition of CO₂ using calibration gas from manufacturer of MOX-Linde Gases Sdn. Bhd as in Appendix 1 and 2.

After have done the calibration of 60-40 percentage composition, another flowmeter was used to control the gas mixture of these two gases to supply sufficient amount of fuel to the applied load. The gas mixture flow rate is recorded to obtain the amount of fuel consumed.

3.5.2 Collection of Gas over Water

For gases that are not particularly soluble in water, it is possible to collect the evolved gas by displacement of water from a container. The simulated biogas gas is collected by attaching one end of a hose to the reaction bottle containing water where the water inside it will flow out through plastic tube that have been mounted on top of the reaction bottle to the other collection scaled container. The displaced water is collected and then using a measuring cylinder its volume would be calculated. The displaced water indicates the total volume of simulated biogas produced. The volume of gas can be determined by the amount of water that was displaced by the simulated biogas. The graph shown below has been tabulated resulted from calibration gas using water displacement method. It is calibrated by measuring 187.5 cm³ in 5 seconds for flowmeter reach out 5mm on its scale.

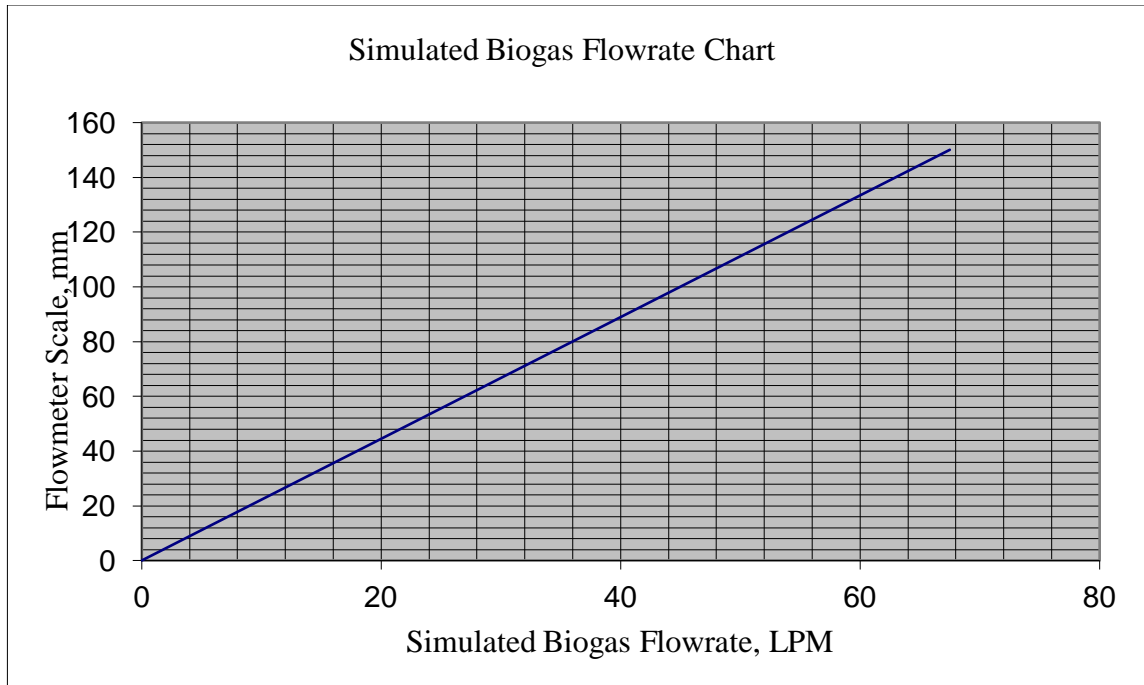

Figure 3.12: Simulated Biogas Flowrate Chart from Water Displacement Method

It would be possible to find its mass of simulated biogas or natural gas alone by using the following equation for each load applied.

$$\dot{m} = \rho V \quad (5)$$

Where,

\dot{m} = Mass flow rate of gas

ρ = Density of gas

V = Volume of gas

Below parameters are needed in calculating the density of simulated biogas.

Where,

ρ of CH_4 = density of CH_4 , 0.668 kg/m^3 at NTP.

ρ of CO_2 = density of CO_2 , 1.842 kg/m^3 at NTP.

As the simulated biogas is synthetically in a mixture form, calculation using moles is required. The relationship of number of mole, molecular weight and the mass of the mixture is as the following:

$$N = \frac{\dot{m}}{M} \quad (6)$$

Where,

N = Number of moles

\dot{m} = Molar mass of simulated biogas mixture

M = Molecular weight of simulated biogas mixture

The calculation is shown in the table 3.4 below.

Table 3.4: Summary of Calculation of Simulated Biogas Mixture Density

Parameter	CO ₂	CH ₄	Mixture	
Constituent moles in each 1 mole of the mixture, n (Kmol)	0.4000	0.6000	Percentage of composition (% volume basis)	60-40
Constituent molecular weight (kg/kmol)	44.01	16.04		
Constituent weight in 1 Kmol of the mixture (kg)	17.60	9.63	Summation of molecular weight (kg/kmol)	27.23
Constituent lower heating Value (kJ/kg)	0.00	49915.00	Lower heating value (kJ/kg)	17644.86
Constituent lower heating value in 1 Kmol of the mixture (kJ)	0.00	480458.93		
Density at NTP (kg/m ³)	1.84200	0.66800	Density of simulated biogas (kg/m ³)	1.43
Molar mass, \dot{m} = Constituent moles in each 1 mole of the mixture x constituent molar Weight x density at NTP	32.43	6.43		

Simple equation is used to find simulated biogas density in calculating density using molecular weight of this compound derived from Equation 5.

$$\rho = \frac{\dot{m}}{V}$$

In this case, $\rho = \text{Summation of both molar mass CH}_4 \text{ and CO}_2 / \text{Summation of both molecular weight of CH}_4 \text{ and CO}_2$.

3.5.3 Detailed Procedure

The engine fuel system is modified by adding a CO₂ cylinder tank and two flow metering system for both CH₄ and CO₂ cylinders which are used for simulated biogas consumption measurement. Experiment set-up is illustrated in Figure 3.13. Simulated biogas is fed into system through high pressure gas hose that can stand up to 150 bar. Tube connections from gas sources to each first stage pressure regulator, from each regulator to flow meter, and to the hose fittings and engine are closely checked and leak test is carried out. To do calibration on percentage of CH₄ composition and CO₂ composition in each flowmeter, CH₄ flow is turned on and the pressure regulator value for CH₄ is monitored, and the knob on flowmeter is adjusted appropriately to 40 mm that is equivalent to 60% CH₄ composition. The CO₂ flow is turned on and the flow is adjusted appropriately to 39 mm which equivalent to 40% CO₂ composition as referring to Appendix 1 and 2 respectively. The pressure is kept constant to 3 bar for both single stage pressure regulator. The engine is started. The bulbs on the bank load are turned on for average and maximum load measurement for 15 minutes each test. As the engine stopped, knob on flow meter for each gas is turned off.

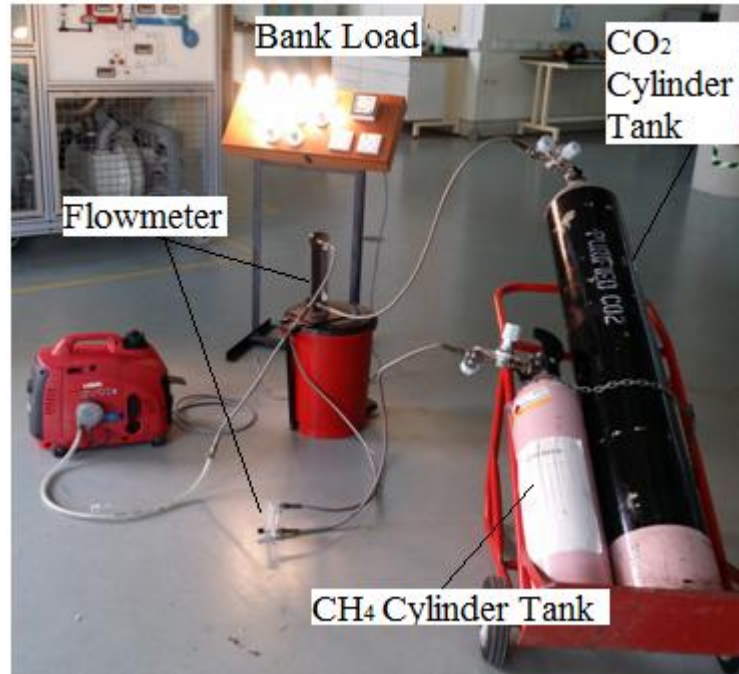

Figure 3.13: Experiment Set-up for Running the Generator with Simulated Biogas

The schematic diagram for running the generator with simulated biogas is shown in Figure 3.14.

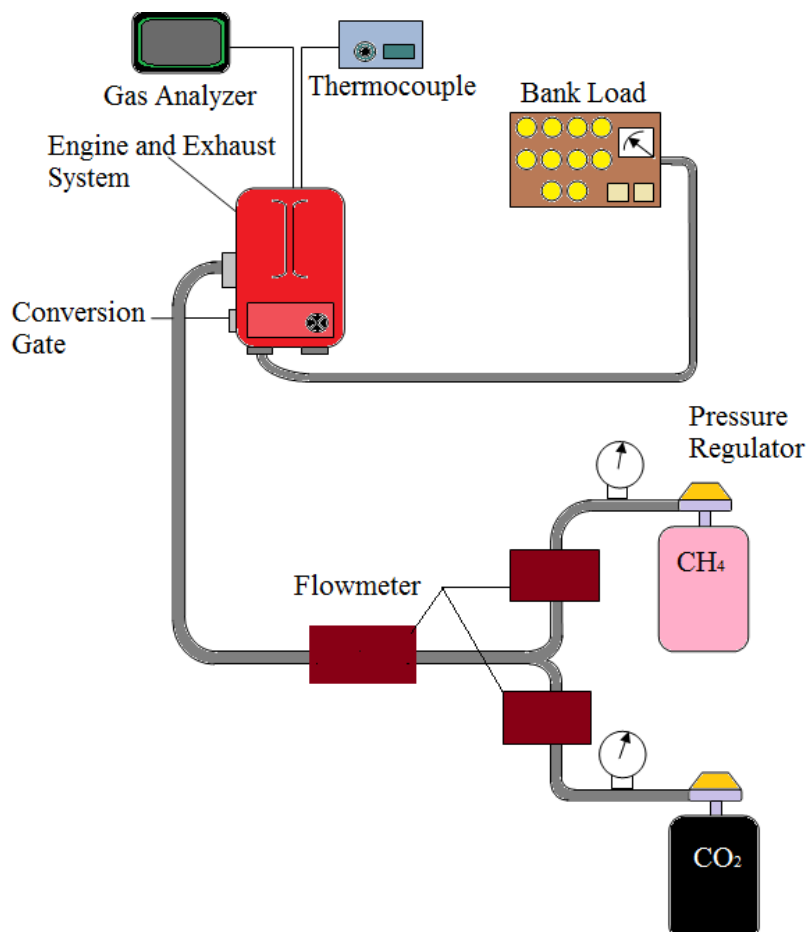

Figure 3.14: Schematic Drawing for Running the Generator with Simulated Biogas

3.6 Progress Work Flow

A proposed progress workflow is shown in Figure 3.15.

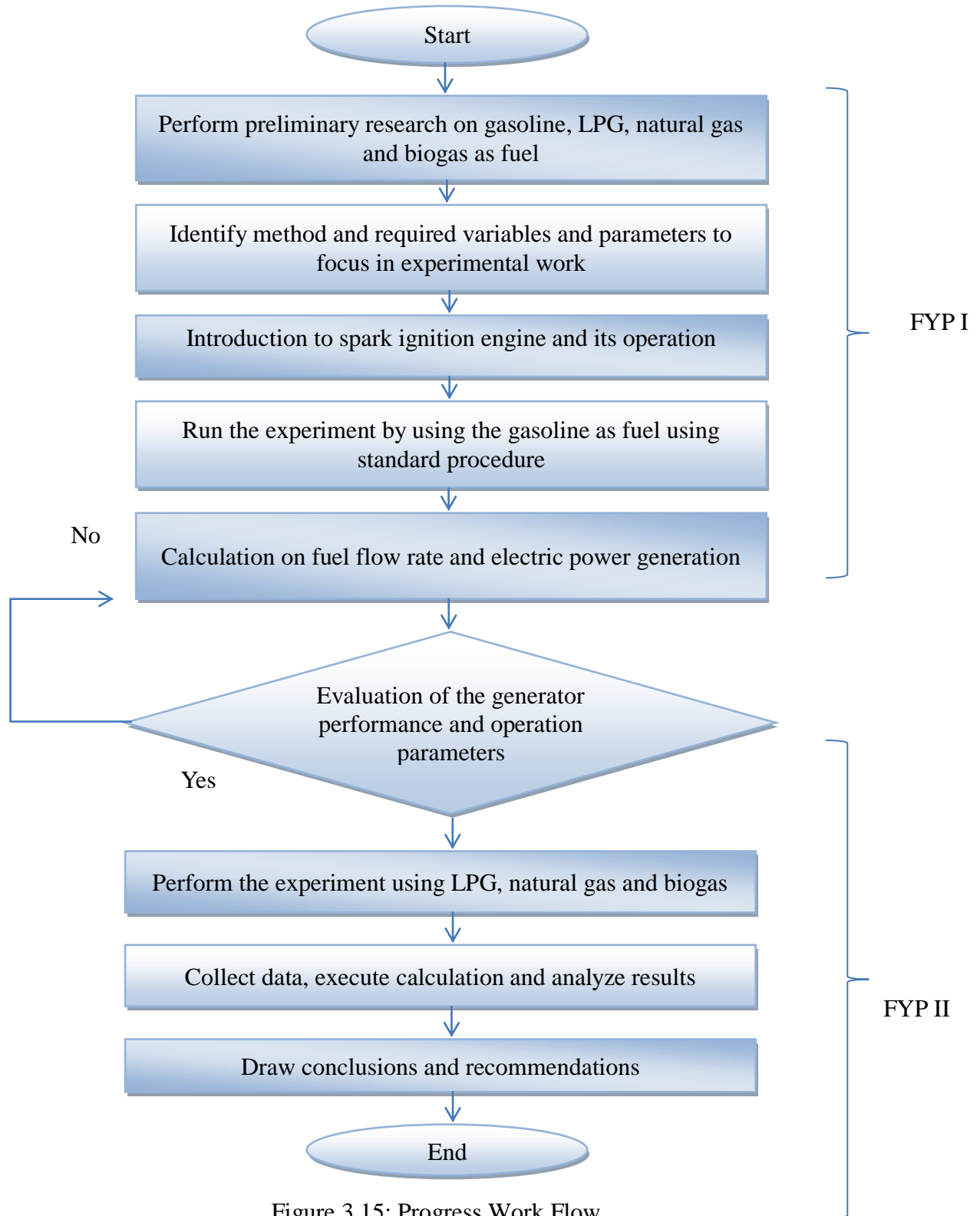
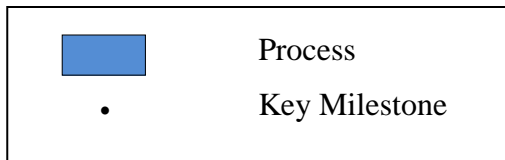

Figure 3.15: Progress Work Flow

3.7 Gantt Chart and Key Milestones

Table 3.5: Project Gantt Chart

Agenda/Week	1-2	3-4	5-6	7-8	9-10	11-12	13-14	1-2	3-4	5-6	7-8	9-10	11-12	13-14
	FYP 1							FYP 2						
Project topic selection	■													
Literature review/ Research work		■												
Run the experiment using gasoline as fuel		■	■											
Submission of extended proposal			•											
Proposal defence				•										
Project work continues					■	■	■							
Submission of interim draft report						•								
Submission of interim report							•							
Simulated biogas setup preparation					•			■	■					
Run the experiment using LPG, natural gas and simulated biogas respectively										■	■			
Submission of progress report												•		
Collect data and analyse result												■	■	
Pre-SEDEX												•		
Submission of draft final report													•	
Submission of dissertation													•	
Submission of technical paper													•	
Viva presentation														•
Submission of project dissertation														•



CHAPTER 4

RESULTS AND DISCUSSIONS

4.1 Introduction

This section presented the finding of the project work. Tests have been conducted on the USR EV10-i spark ignition generator engine. The data was tabulated in the Table 4.1 and the result was shown in Figure 4.1 as below.

Table 4.1: Data from Experimental Work

Current Consumption (Ampere, A)			
Bulb 1	0.00	Bulb 6	2.42
Bulb 2	0.50	Bulb 7	2.80
Bulb 3	1.00	Bulb 8	3.24
Bulb 4	1.45	Bulb 9	3.70
Bulb 5	2.10	Bulb 10	4.18

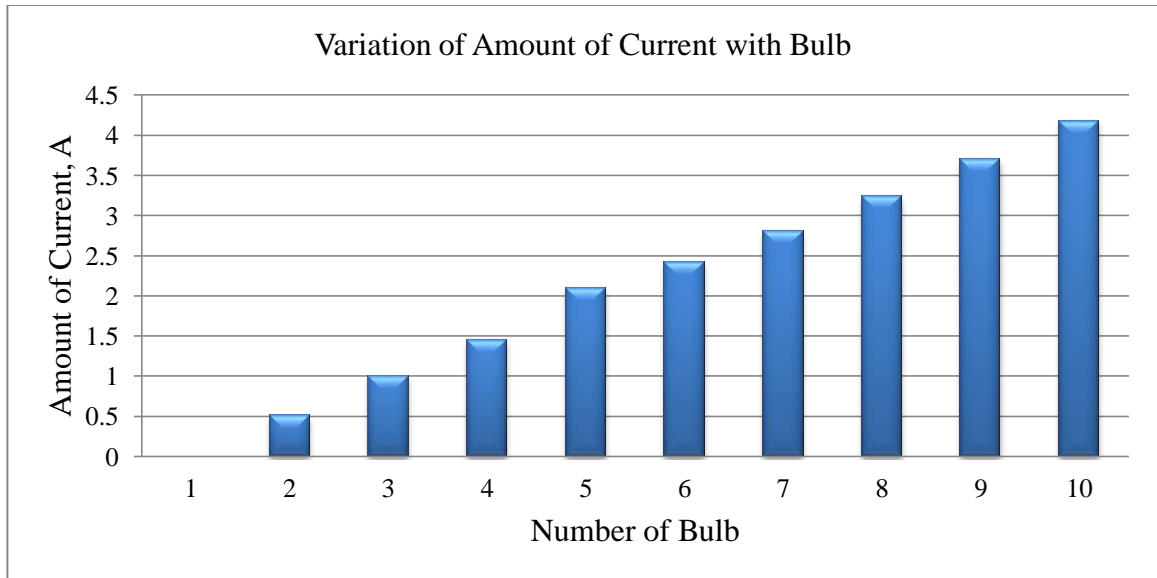

Figure 4.1: Variation of Amount of Current with Bulb

4.2 Engine Performance

The engine performance is indicated by the term efficiency, η . The engine performance parameters are such fuel flow rate, specific fuel consumption, energy efficiency, temperature and exhaust emissions at various loads applying on the engine.

4.2.1 Variation of Electric Power Calculation with Bulb

As according to the USR EV10-i portable inverter generator specification, it employed AC single phase and using the formula of power factor shown in Equation 7. (Beaty, 2011).

$$\text{AC Single Phase Power Factor, kW} = \text{PF} \times \text{A} \times \text{V} / 1000 \quad (7)$$

Where,

PF = Power factor

A = Current, in Ampere, (A)

V = Voltage, in Volt, (V)

Therefore, as single phase is used, its power factor is 1. Electrical power generation for each data was calculated and was tabulated in the Table 4.2. The graph was shown in Figure 4.2.

Table 4.2: Calculation for Electric Power Generation

Power Consumption (KiloWatt, kW)			
Bulb 1	0.00	Bulb 6	0.58
Bulb 2	0.12	Bulb 7	0.67
Bulb 3	0.24	Bulb 8	0.78
Bulb 4	0.35	Bulb 9	0.89
Bulb 5	0.50	Bulb 10	1.00

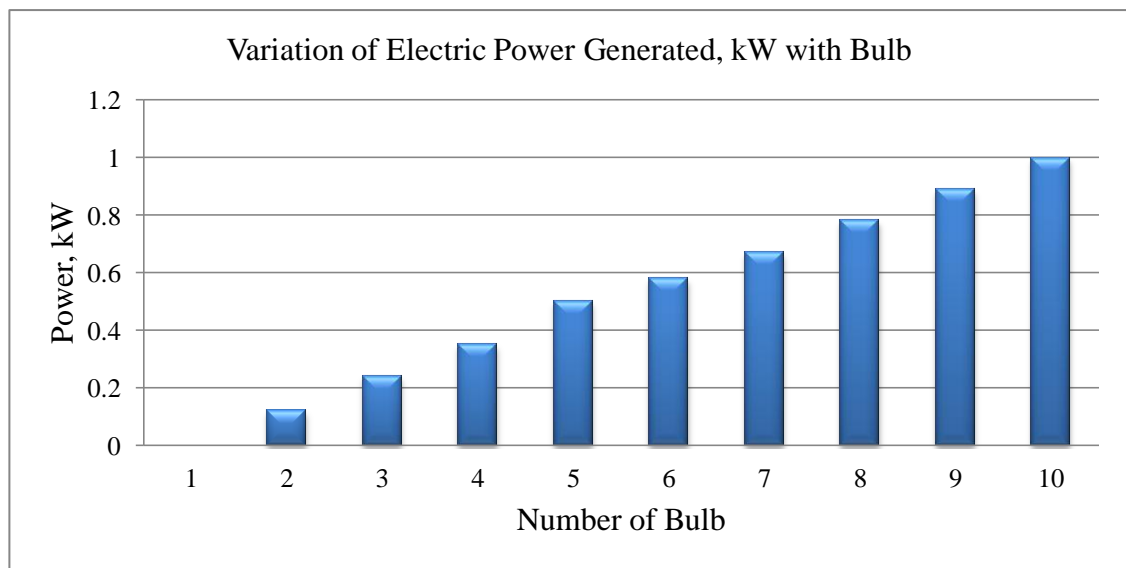

Figure 4.2: Variation of Power Generated, kW with Bulb

4.2.2 Variation of Fuel Flow Rate with Load

Gasoline consumed rate was assessed in the different output powers of generator. The result for fuel flow rate for each fuel was tabulated as in Table 4.3, 4.4, 4.5 and 4.6 respectively.

The calculation for fuel consumed rate:

Average load = 50 g

$$\text{Fuel consumed rate, } \left(\frac{g}{h}\right) = \left(\frac{50 g}{15 min}\right) \left(\frac{60 min}{1 hour}\right) = 200 \frac{g}{h}$$

Maximum load = 100 g

$$\text{Fuel consumed rate, } \left(\frac{g}{h}\right) = \left(\frac{100 g}{15 min}\right) \left(\frac{60 min}{1 hour}\right) = 400.20 \frac{g}{h}$$

Table 4.3: Amount of Gasoline Consumed For Average and Maximum Load Modes

Type of Load/Weight	Average Weight (Before test), kg	Average Weight (After test), kg	Weight Differences (fuel consumed), kg	Fuel Consumed Rate, g/h
Average Load	15.80	15.75	0.05	200
Maximum Load	15.90	15.80	0.10	400.20

LPG consumed rate was assessed in the different output powers of generator.

The calculation for fuel consumed rate:

Average load = 48 g

$$\text{Fuel consumed rate, } \left(\frac{g}{h}\right) = \left(\frac{48 g}{15 min}\right) \left(\frac{60 min}{1 hour}\right) = 192 \frac{g}{h}$$

Maximum load = 90 g

$$\text{Fuel consumed rate, } \left(\frac{g}{h}\right) = \left(\frac{90 g}{15 min}\right) \left(\frac{60 min}{1 hour}\right) = 360 \frac{g}{h}$$

Table 4.4: Amount of LPG Consumed For Average and Maximum Load Modes

Type of Load/Weight	Average Weight (Before test), kg	Average Weight (After test), kg	Weight Differences (fuel consumed), kg	Fuel Consumed Rate, g/h
Average Load	20.00	19.952	0.048	192
Maximum Load	19.95	19.86	0.09	360

Natural gas consumed rate was assessed in the different output powers of generator. Using calibration graph of CH₄ plotted using calibration gas from manufacturer of MOX-Linde Gases Sdn. Bhd. as in Appendix 1.

Average load = 4.412 LPM using 100% CH₄

Using Equation 5, $\dot{m} = \rho V$

The term for fuel consumed rate is equivalent to mass flow rate, \dot{m} .

$$\begin{aligned} &\text{Fuel consumed rate, } \left(\frac{g}{h}\right) \\ &= \left(\frac{4.412 \text{ litre}}{\text{min}}\right) (100\%) \left(\frac{0.001 \text{ m}^3}{1 \text{ litre}}\right) \left(\frac{60 \text{ min}}{1 \text{ hour}}\right) \left(\frac{0.668 \text{ kg}}{\text{m}^3}\right) \left(\frac{1000 \text{ g}}{1 \text{ kg}}\right) = 176.83 \frac{g}{h} \end{aligned}$$

Maximum load = 7.65 LPM using 100% CH₄

$$\begin{aligned} &\text{Fuel consumed rate, } \left(\frac{g}{h}\right) \\ &= \left(\frac{7.65 \text{ litre}}{\text{min}}\right) (100\%) \left(\frac{0.001 \text{ m}^3}{1 \text{ litre}}\right) \left(\frac{60 \text{ min}}{1 \text{ hour}}\right) \left(\frac{0.668 \text{ kg}}{\text{m}^3}\right) \left(\frac{1000 \text{ g}}{1 \text{ kg}}\right) = 306.6 \frac{g}{h} \end{aligned}$$

Table 4.5: Amount of Natural Gas Consumed For Average and Maximum Load Modes

100% CH ₄						
Load Description	Amount of Load (kW)	CH ₄ (L/min)	CO ₂ (L/min)	CO (L/min)	H ₂ (L/min)	Fuel Consumed Rate, g/h
Average load	0.5	4.412	0	0	0	176.83
Maximum load	1.00	7.65	0	0	0	306.6

Simulated biogas consumed rate was assessed in the different output powers of generator. The fuel consumed rate was determined using water displacement method.

Using the graph in Figure 3.14, the average load = 7.3125 LPM and the maximum load = 11.7 LPM respectively.

$$\begin{aligned} & \text{Mass flow rate of simulated biogas for average load, } \left(\frac{g}{h}\right) \\ & = \left(\frac{7.3125 \text{ litre}}{\text{min}}\right) \left(\frac{0.001 \text{ m}^3}{1 \text{ litre}}\right) \left(\frac{60 \text{ min}}{1 \text{ hour}}\right) \left(\frac{1.43 \text{ kg}}{\text{m}^3}\right) \left(\frac{1000 \text{ g}}{1 \text{ kg}}\right) = 627.413 \frac{g}{h} \end{aligned}$$

$$\begin{aligned} & \text{Mass flow rate of simulated biogas for maximum load, } \left(\frac{g}{h}\right) \\ & = \left(\frac{11.7 \text{ litre}}{\text{min}}\right) \left(\frac{0.001 \text{ m}^3}{1 \text{ litre}}\right) \left(\frac{60 \text{ min}}{1 \text{ hour}}\right) \left(\frac{1.43 \text{ kg}}{\text{m}^3}\right) \left(\frac{1000 \text{ g}}{1 \text{ kg}}\right) = 1003.86 \frac{g}{h} \end{aligned}$$

Table 4.6: Amount of Simulated Biogas Consumed For Average and Maximum Load Modes

60% CH ₄ and 40% CO ₂					
Load Description	Amount of Load (kW)	Simulated Biogas Mixture (L/min)	CO (L/min)	H ₂ (L/min)	Fuel Consumed Rate, g/h
Average load	0.5	7.3125	0	0	627.413
Maximum load	0.8	11.7	0	0	1003.86

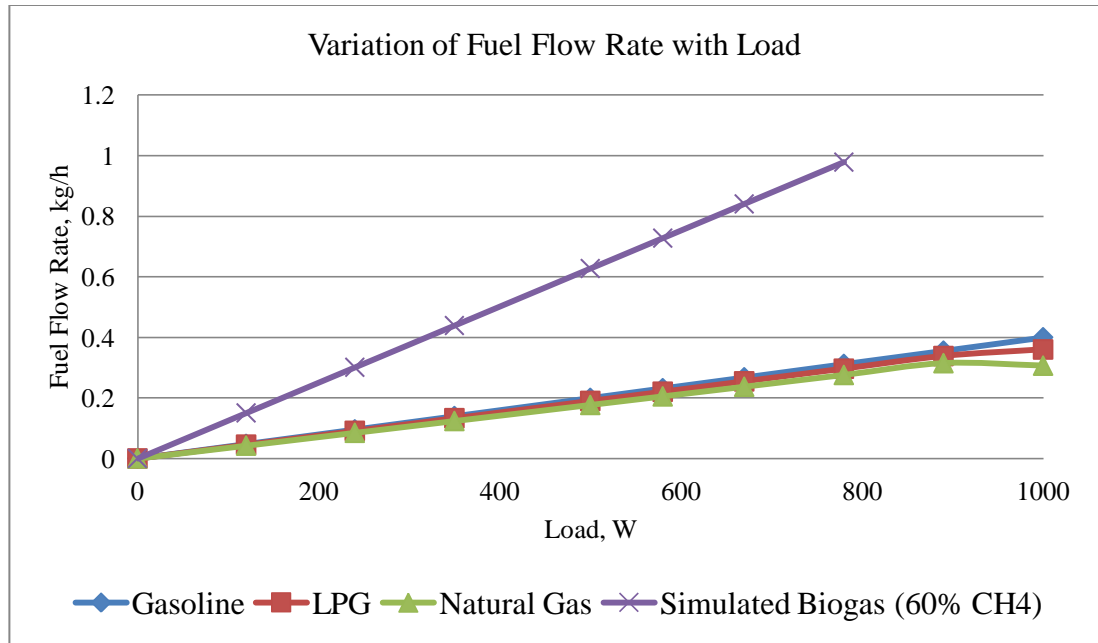

Figure 4.3: Variation of Fuel Flow Rate with Load

Figure 4.3 showed the variation of fuel flow rate with load. For LPG and natural gas, low fuel flow rate was needed to generate enough heat input to support the load applied. Furthermore, at average load, the fuel flow rate for LPG and natural gas was decreased to 5% and 11.5% respectively. Meanwhile, at maximum load, the fuel flow rate was decreased to 10% and 23.4% respectively as compared to gasoline. Using simulated biogas, it consumed 0.4kg/h more than gasoline to generate 500 W. Using simulated biogas, higher fuel flow rate was needed to generate enough heat input to support the load applied. As this engine has fixed engine speed, the air flow was limited. Hence the maximum load that the engine was capable of supporting gas decreased and it was observed, it can only supply load up to 780 W due to lower methane content in the simulated biogas compared to natural gas. As heating value of simulated biogas was lower than gasoline, higher fuel flow rate was required into the engine to produce the same power output.

4.2.3 Variation of Specific Fuel Consumption with Load

Specific fuel consumption, sfc is one of the engine performance parameters. Figure 4.4 showed the variation of specific fuel consumption with load.

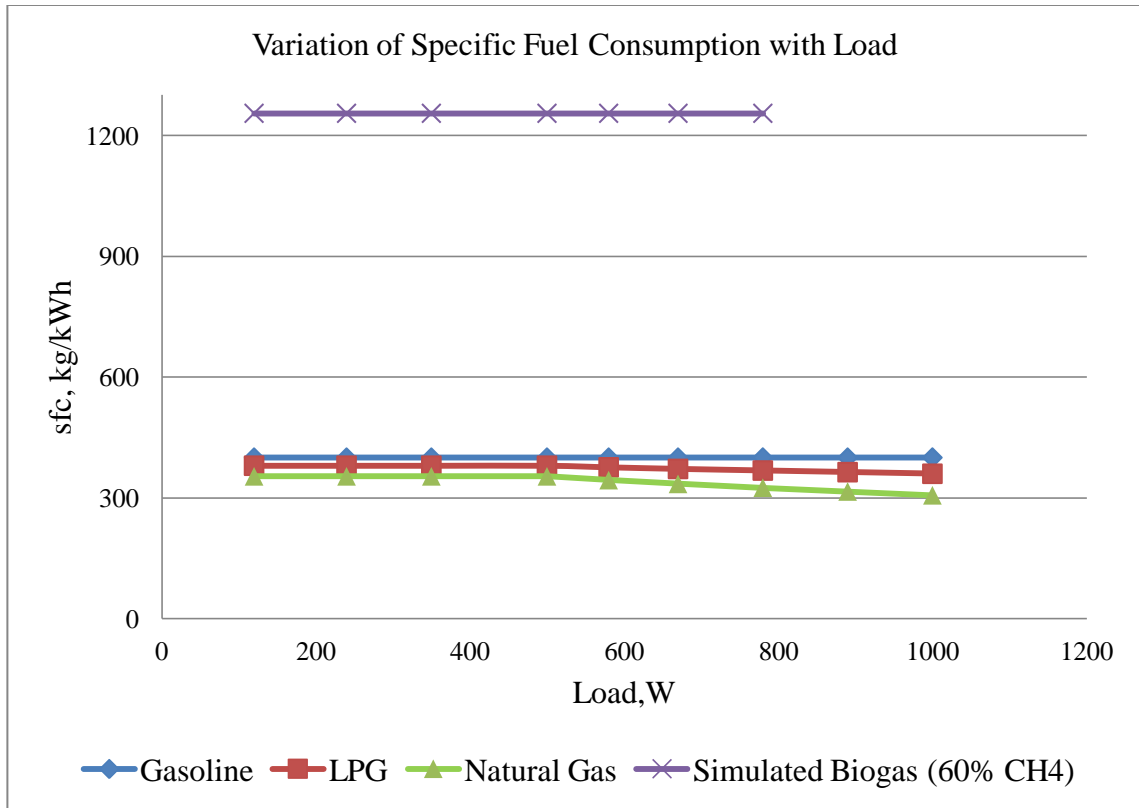

Figure 4.4: Variation of Specific Fuel Consumption with Load

The sfc of the engine for running with gasoline fuel was around 400 g/kWh at 500 W and increased to value 400.2 g/kWh to the maximum rated load, 1000 W.

For running with LPG, the rate of fuel consumption was increased with loading. It was around 380 g/kWh at 500 W and was increased to value to 360 g/kWh for 1000 W of power generation. Compared to gasoline, running the engine on LPG resulted in around 10% decrease in consumption to produce same maximum power rated, 1000 W.

The physical and chemical properties of natural gas are different from gasoline fuel properties. Therefore, its use in Otto engines also differs. Natural gas has the highest calorific value (lower heating value) as shown in Table 3.1 Fuel Gas Properties where for the engine to develop the same power as when using gasoline (baseline case), it already has satisfactory fuel and hence, it has lower sfc, as compared to gasoline fuel. The sfc of the engine for running with natural gas was 380 g/kWh at 500 W and it was

decreased to value of 306.6 g/kWh at 1000 W which resulted in 23.4% decreased in consumption to produce same maximum power rated, 1000 W when compared to gasoline.

For running with simulated biogas, the values of specific fuel consumption were much higher compared to running with gasoline. Specific fuel consumption was 1254.83 kg/kWh up to 780 W for simulated biogas with 60% methane. The relatively higher density of the CO₂ gas presented in the biogas did not take part in combustion but its presence caused the large increase in fuel mass and as well as it has increased in sfc value, and it resulted in 68.11% increase in consumption and power reduction of 22% when achieved 780 W load as comparing to gasoline.

Higher fuel consumption and greater environmental pollution was relatively caused by poor mixing of fuel with air in the small engine that seemed to be the main reason of poor combustion. From Figure 4.4, it verifies that using simulated biogas consumed more fuel to support the applied load. The heat loss to the combustion chamber wall is proportionately greater and combustion efficiency is poorer, resulting in higher fuel consumption for the power produced.

4.2.4 Variation of Engine Efficiency with Load

By using Equation 2 but define the power specifically as electric power, the result of calculation was as in Figure 4.5.

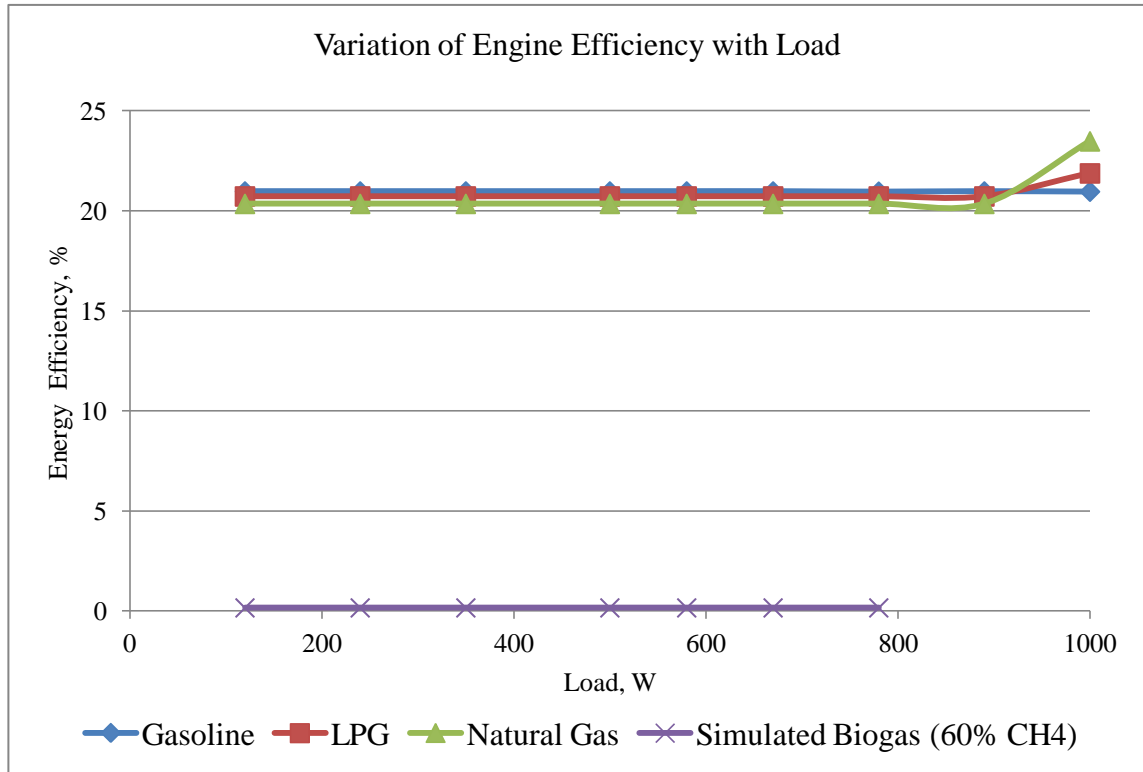

Figure 4.5: Variations of Engine Efficiency with Load

Figure 4.5 showed the variation of engine efficiency with load. Gasoline has the engine efficiency of 21% which was close to the theoretical highest value of thermal efficiency when running the gasoline fuelled generator. LPG generated 20.7% while natural gas generated 20.4% and simulated biogas generated only 0.16% of engine efficiency correspondingly. Calorific value or known as lower heating value of simulated biogas was lower in value than the other fuels though its mass flow rate was not much vary compared to gasoline caused it to have lower engine efficiency.

4.2.5 Variations of Temperature with Load

The variation of temperature of each fuel was also considered. Figure 4.6 shows the variation of exhaust gas temperature with different type of fuels and loads correspondingly.

Table 4.17: Variation of Temperature with Load

Type of Fuel	Variation of Load	Temperature, (°C)
Gasoline	Average	150.0 °C
	Maximum	240.0°C
LPG	Average	159.8 °C
	Maximum	255.7 °C
Natural Gas	Average	269.4 °C
	Maximum	326.6 °C
Simulated Biogas	Average	224.5 °C
	Maximum	253.9 °C

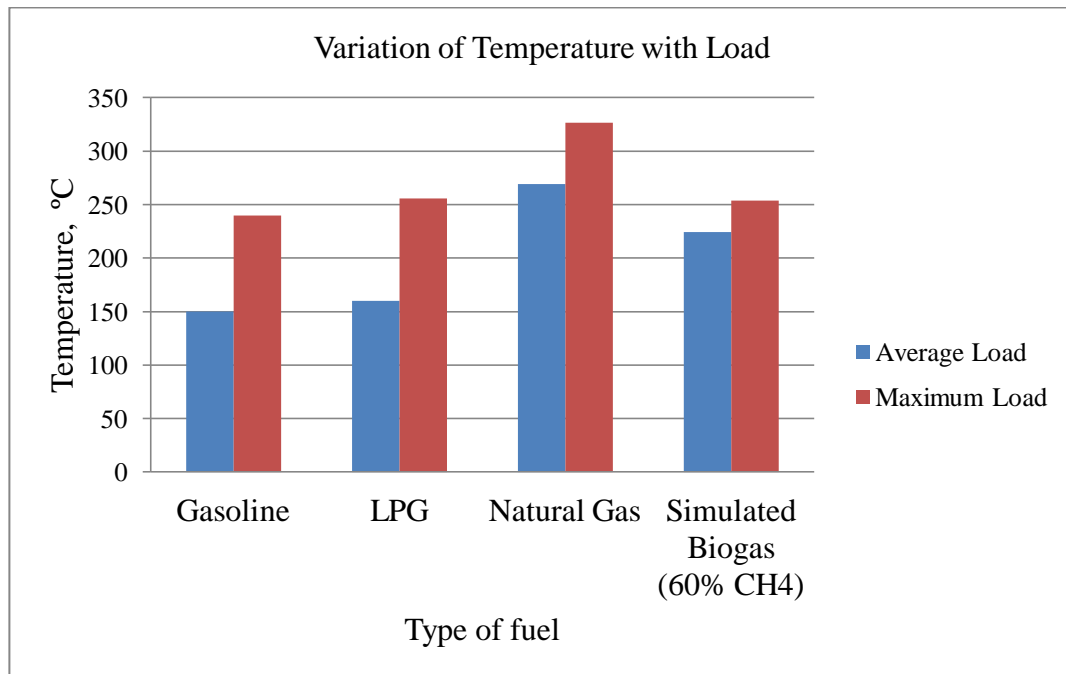

Figure 4.6: Variation of Temperature with Load

From temperature variation, heat release could be analyzed from the engine combustion. It has been observed that the exhaust gas temperature for simulated biogas has greater value for both average and maximum loads as compared to gasoline, LPG, natural gas to produce same power. However, in the comparison between natural gas and simulated biogas, theoretically, an increase in the exhaust temperature is always associated with retardation of ignition timing and an incomplete combustion. Natural gas that contained purified methane has different combustion features than simulated biogas because of no CO₂ content. It combusted faster and at high temperature that required different adjustment of ignition timing. Even more, another characteristic of simulated biogas was that the temperature of its flame is high, where it proved that it have higher exhaust gas temperature than natural gas.

4.2.8 Variation of Exhaust Emissions with Load

The variation of exhaust gas emissions on varying load was also studied. The result from the exhaust emission for each fuel was tabulated as in Table 4.8, 4.9, 4.10 and 4.11 respectively.

Table 4.8: Components Detected in Exhaust Emissions with Gasoline

No of bulb /Components detected	Carbon Dioxide, CO ₂ (%)	Carbon Monoxide, CO (%)	Oxygen, O ₂ (%)	Hydrocarbon, HC (ppm)	Nitrogen Oxide, NO (ppm)	Stoichiometric Ratio, λ
2 bulbs	4.9	6.91	6.94	476	19	1.094
4 bulbs	5.8	7.70	4.93	318	34	0.959
6 bulbs	6.8	8.86	2.47	317	54	0.820
8 bulbs	7.5	10.31	0.27	316	73	0.707956
10 bulbs	7.0	10.96	0.31	330	61	0.690128

Table 4.9: Components Detected in Exhaust Emissions with LPG

No of bulb /Components detected	Carbon Dioxide, CO ₂ (%)	Carbon Monoxide, CO (%)	Oxygen, O ₂ (%)	Hydrocarbon, HC (ppm)	Nitrogen Oxide, NO (ppm)	Stoicheometric Ratio, λ
2 bulbs	7.4	1.70	7.62	144	65	1.483952
4 bulbs	6.9	1.98	6.10	213	139	1.35579
6 bulbs	8.6	3.07	3.46	275	246	1.073
8 bulbs	11.0	3.04	0.92	278	434	0.937
10 bulbs	10.4	0.11	4.41	139	288	1.27404

Table 4.10: Components Detected in Exhaust Emissions with Natural Gas

No of bulb /Components detected	Carbon Dioxide, CO ₂ (%)	Carbon Monoxide, CO (%)	Oxygen, O ₂ (%)	Hydrocarbon, HC (ppm)	Nitrogen Oxide, NO (ppm)	Stoicheometric Ratio, λ
2 bulbs	6.2	1.93	8.52	82	45	1.612449
4 bulbs	6.6	1.49	6.62	76	102	1.47754
6 bulbs	8.6	0.94	4.11	80	281	1.246541
8 bulbs	10.4	1.08	0.91	91	500	1.009
10 bulbs	10.1	0.10	2.10	62	756	1.137

Table 4.11: Components Detected in Exhaust Emissions with Simulated Biogas

No of bulb /Components detected	Carbon Dioxide, CO ₂ (%)	Carbon Monoxide, CO (%)	Oxygen, O ₂ (%)	Hydrocarbon, HC (ppm)	Nitrogen Oxide, NO (ppm)	Stoicheometric Ratio, λ
2 bulbs	5.9	2.15	7.98	120	37	1.554214
4 bulbs	8.0	2.83	5.57	124	46	1.227205
6 bulbs	10.5	2.86	0.59	114	63	0.929
8 bulbs	11	3.15	0.61	120	68	0.918268
10 bulbs	-	-	-	-	-	-

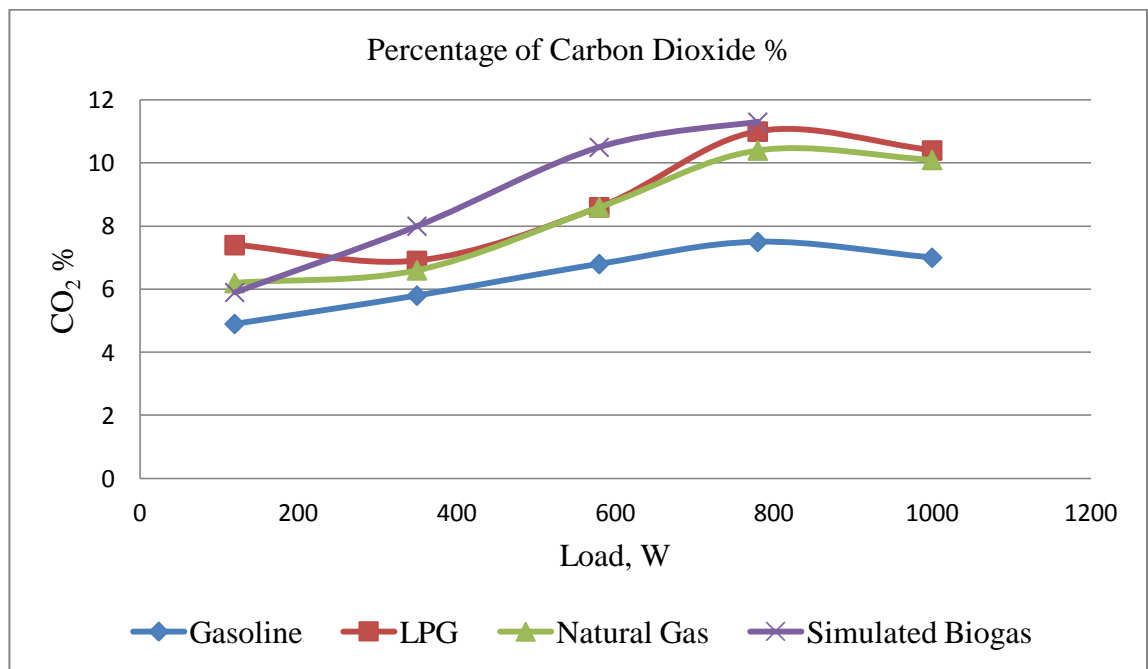

Figure 4.7: Percentage of Carbon Dioxide in Exhaust Emission

Percentage of carbon dioxide is showed in Figure 4.7. The presence of carbon dioxide represented how well the air/fuel mixture is burned in the engine. This gas gave a direct indication of combustion efficiency. Comparing of all type of fuels, simulated biogas has the highest percentage of carbon dioxide. The presence of this non-

combustible gas may be due to amount of carbon dioxide content in simulated biogas of 40% in the mixture which was a huge amount of CO₂ gas.

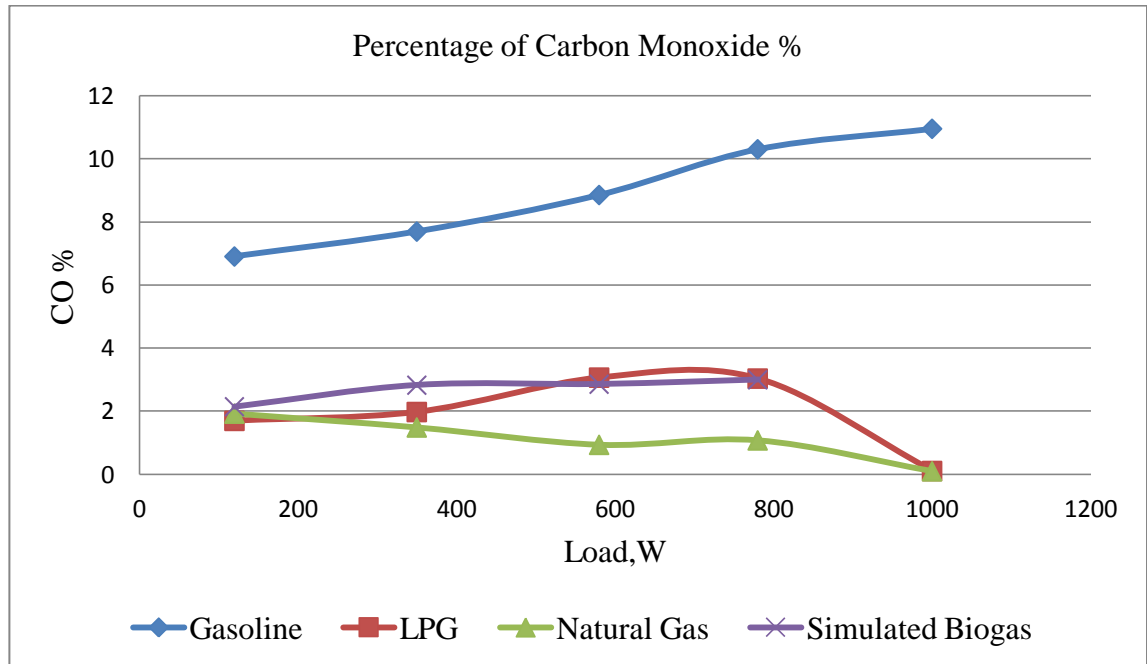

Figure 4.8: Percentage of Carbon Monoxide in Exhaust Emission

Figure 4.8 illustrated the percentage of carbon monoxide in exhaust emission. CO emission was raised sharply for gasoline and simulated biogas as the reason it ran with the fuel-rich mixture where in the presence of CO revealed it has undergone incomplete combustion. Natural gas is a cleaner fuel than either gasoline or LPG as far as emissions are concerned. Natural gas has resulted significantly lower emission of CO as compared to gasoline, LPG and simulated biogas. This clearly showed that natural gas has advantage from the environment perspective and has supported declaration from researchers that natural gas was considered to be an environmentally clean alternative to those fuels (Cho and He, 2007; Kato et al., 1999; Shashikantha and Parikh, 1999; Wayne, 1998). CO₂ content in simulated biogas is as much as 40% composition which is quite a huge amount and the high presence in CO₂ was expected to produce more pollutants in emissions.

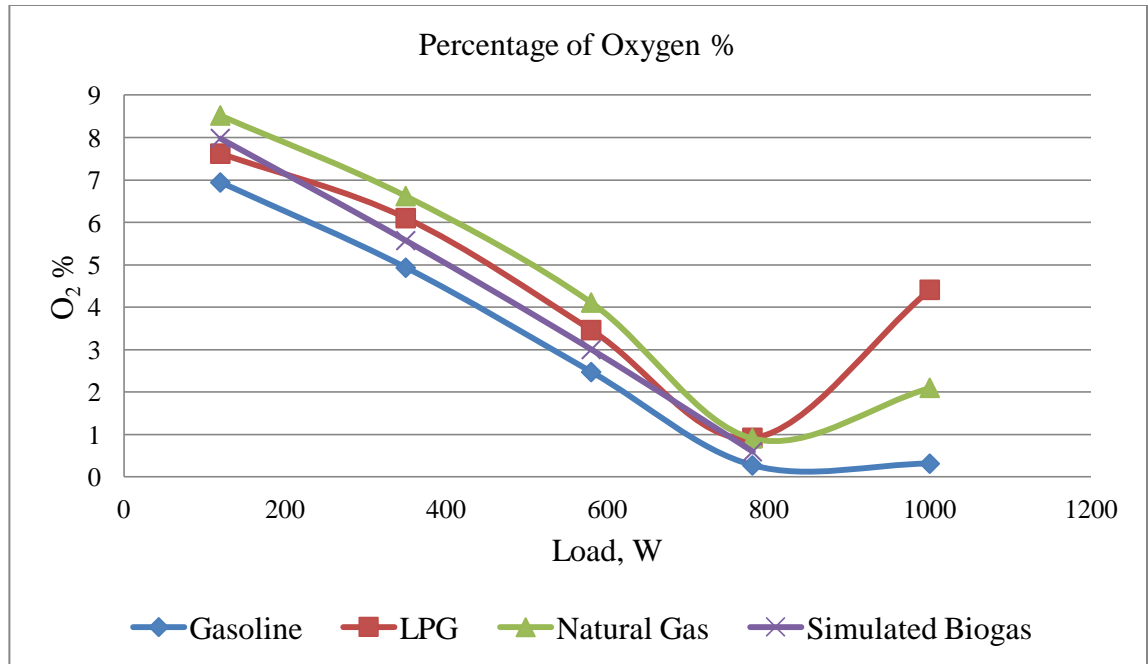

Figure 4.9: Percentage of Oxygen in Exhaust Emission

Figure 4.9 displayed the percentage O₂ in exhaust emission. Having O₂ raised in the emission reflected that there was an excess of air in the mixture. The O₂ content was raised sharply as soon as λ was increased to more than 1. If the combustion chamber contained high percentage of CO₂, the O₂ content was a clear indicator of the transition from rich to lean mixture range. In the graph above, LPG, natural gas and simulated biogas linearly followed the pattern of gasoline baseline but the amount of O₂ was higher than in gasoline.

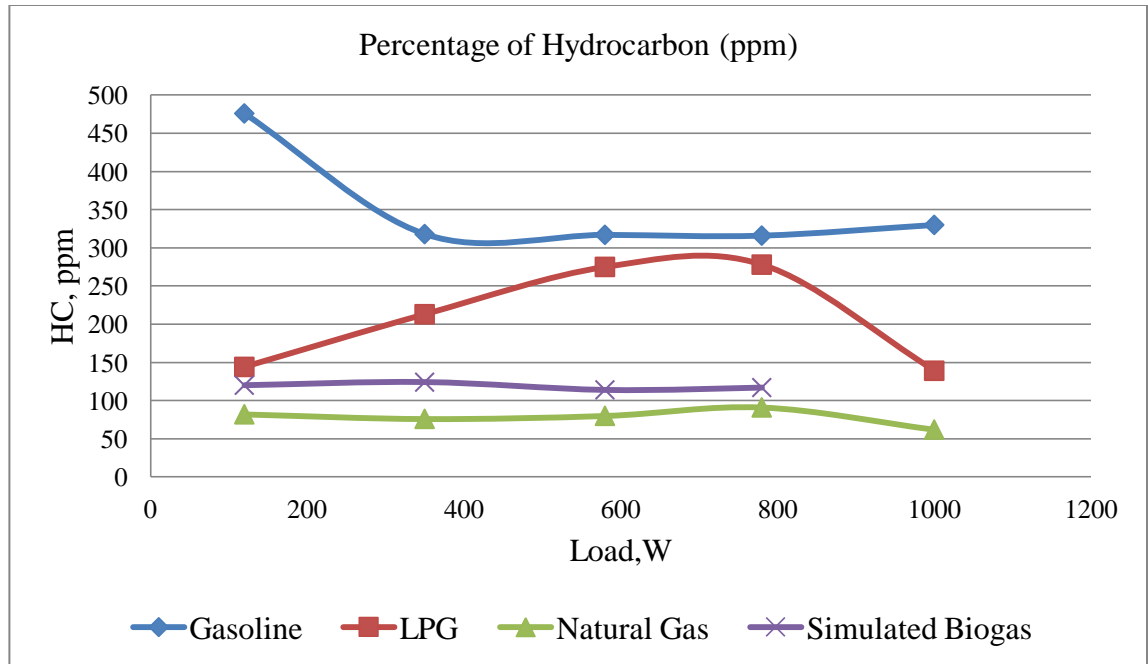

Figure 4.10: Percentage of Hydrocarbon in Exhaust Emission

Figure 4.10 above showed the percentage of hydrocarbon at various loads. HC emissions had similar tendencies to CO emissions. The HC emissions was increased with CO₂ percentages and decreased with electrical load. High CO₂ fraction in a fuel leads worse combustion in the engine cylinder, and the engine efficiency was increased with electrical load. Also, between 0.6kW and 0.8kW load conditions for all fuels, the HC emissions are about to constant for all fuels as CO₂ blended steadily despite increase in load.

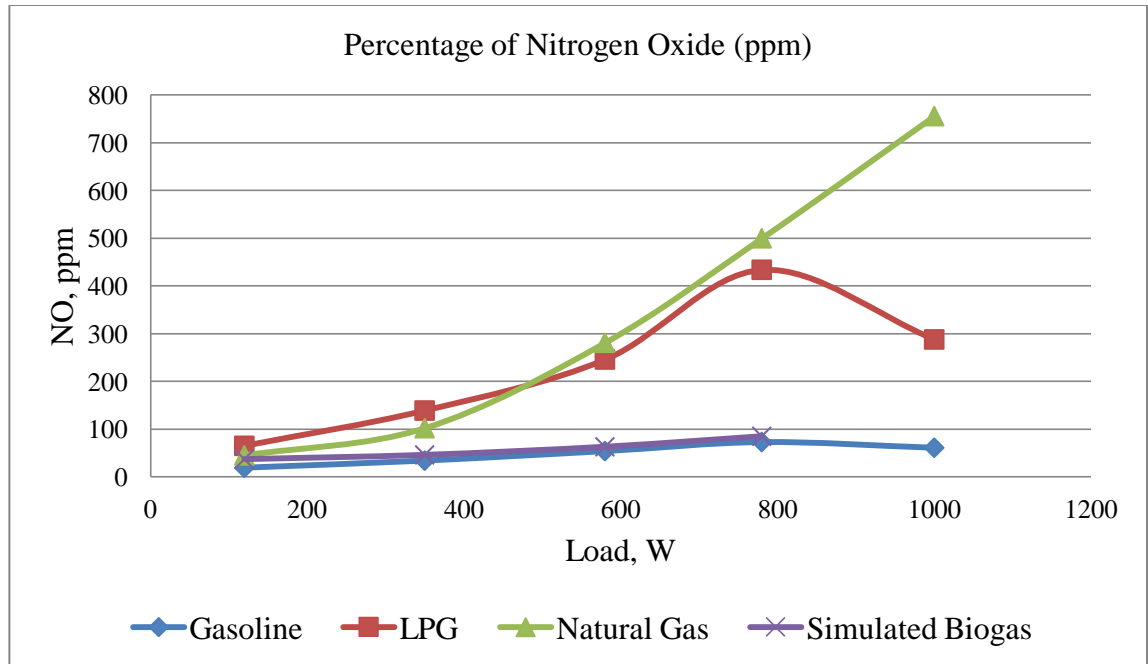

Figure 4.11: Percentage of Nitrogen Oxide in Exhaust Emission

As shown in Figure 4.11, NO_x emission was lower when the content of CO_2 in the fuel is in a high amount. However, NO_x increased with electrical load. NO_x formation was straightforwardly related to the flame temperature in an engine cylinder. The higher the flame temperature, the more the NO_x formation. At 0.8kW to 1.0 kW load using LPG, the percentage of CO_2 in LPG gas is higher, the NO_x emission decreased by 33.6% at these two load variation. It means that the presence of CO_2 in fuel mixtures lowered the flame temperature. For LPG, the reason why NO_x decreased with loads is due to the need of more fuel to generate more power leading higher flame temperature in a combustion chamber.

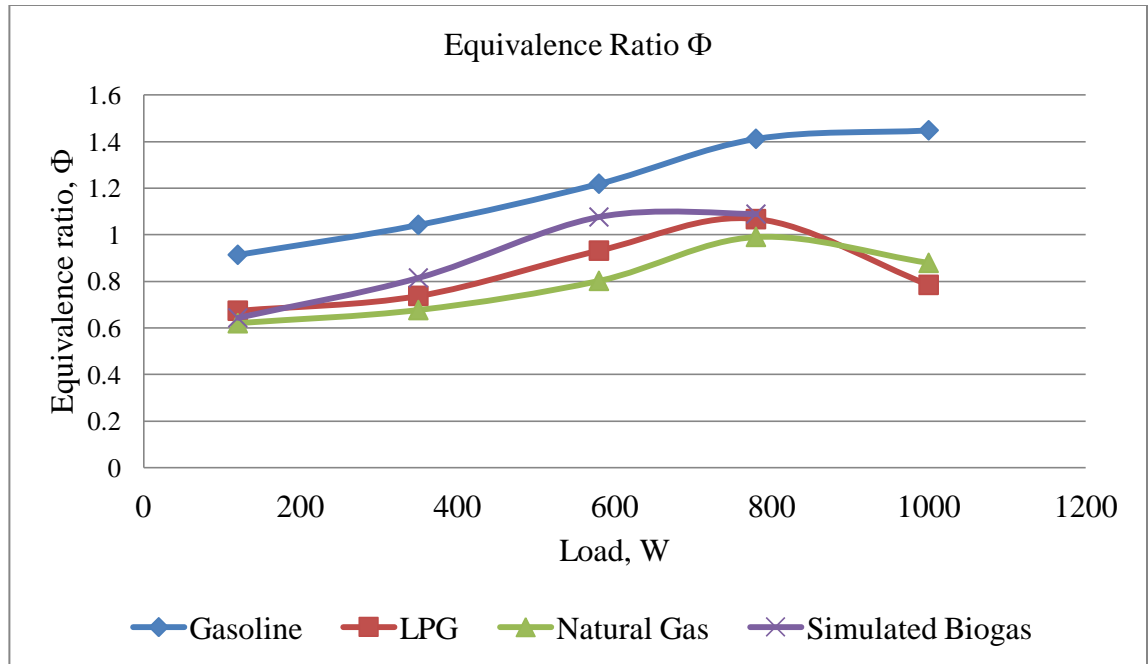

Figure 4.12: Equivalence Ratio

Figure 4.12 referred to the equivalence ratio calculated from stoichiometric ratio obtained. $\Phi < 1$ implied a lean mixture. It became lower due to excess air and hence, the engine efficiency increased. LPG, natural gas and simulated biogas imitated this kind of pattern. For gasoline, the condition happened the other way around. $\Phi > 1$ as the load was applied from 350W to the maximum load. This has showed that it has insufficient air in combustion process.

CHAPTER 5

CONCLUSION AND RECOMMENDATION

The progress work described the performance evaluation of 1 kW portable engine power generator with the minimum possible modifications when the experiments were carried out at constant engine speed under load transients.

The prominent findings were as follows.

1. Engine performances such as fuel flow rate, specific fuel consumption, energy efficiency, temperature and exhaust emissions were measured for various modes.
2. The small scale electric generator using SI engine could be run on LPG, natural gas and simulated biogas with simple modifications as the performance for each fuel was satisfactory comparable with gasoline.
3. It was easier to start the engine with gasoline but switching over to LPG, natural gas or simulated biogas fuel supply system would need some time. While running on LPG, natural gas, simulated biogas the flow rate needed to be regulated to achieve stable engine operation with varying load.
4. Using LPG and natural gas respectively in the engine resulted in a better mixing, combustion and improved emission characteristics compared to simulated biogas.
5. Based on the experimental work, the engine ran stable and has produced electricity using simulated biogas. However, spark ignition engine operation with simulated biogas containing significant fractions of inert gases such as CO₂

displayed has decreased the performance compared with gasoline, LPG and natural gas. Thus, the emission of CO has increased too.

6. Based on the emission analysis, natural gas represented a good fuel where it emitted lower emissions from exhaust system while simulated biogas also has brought significant reductions in CO, HC and NO_x and it is proven would help to reduce harmful greenhouse gas emission.
7. Because of the net calorific value of gasoline, LPG and natural gas was greater than that of the simulated biogas, it meant that to cover the same amount of power, greater amount of simulated biogas was needed.

As a future work, it is recommended to use actual biogas from nature sources as using simulated biogas has been satisfactory comparable with gasoline, LPG, and natural gas. The significance of using actual biogas is a reduced emission of methane from landfill gases. In addition to the built-in automatic throttle (speed) control mechanism, the fixed speed engine needed additional flow regulation to control liquefied gas as well as compressed gas flow to support the variation in the electric load applied. Should be there is improvement of mixing chamber and cooling system of the engine. It is better if simulated biogas is already in the mixture form. Hence, the calibration on percentage of CH₄ and CO₂ from different cylinder tank could be neglected. From the result, the composition itself needs to change to a more suitable composition as to reduce the unnecessary emission from exhaust system while increasing its efficiency.

CHAPTER 6

REFERENCES

- Beaty, H. W. (2011). Handbook of Electric Power Calculations, Third Edition. Instrumentation, Chapter (McGraw-Hill Professional). Access Engineering.
- Brettschneider, J. (1979). Bosh Technishe Berichte, Volume 6 No. 4, page 177-186.
- Cho, H. M.; He, Bang-Quan (2007). Spark ignition natural gas engines - A review. Energy Conversion and Management 48: 608–618.
- Crookes, R. J. (2006). "Comparative bio-fuel performance in internal combustion engines." Biomass and Bioenergy 30(5): 461-468.
- EIA. (2010). International Energy outlook. Energy Information Administration, Department of Energy, U.S.A.
- Ganesan, V. (2004). Internal Combustion Engine (2nd ed.). McGraw-Hill.
- Garcilasso, V. P., Velazquez, S. M. S.G., Coelho, S. T., Silva, L. S. (2011). "Electric Energy Generation from Landfill Biogas" : *Case Study and Barriers*.
- Himabindu, M. and Ravikrishna R. V. (2014). "Performance Assessment of a Small Biogas-fuelled Power Generator Prototype." Journal of Scientific & Industrial Research Vol. 73: pp. 781-785.
- Huang, J. and Crookes R. J. (1998). "Assessment of simulated biogas as a fuel for the spark ignition engine." Fuel 77(15): 1793-1801.

Kato, K.; Igarashi, K.; Masuda, M.; Otsubo, K.; Yasuda, A.; Takeda, K.; Sato, T. (1999). Development of engine for natural gas vehicle. SAE Paper. 1999-01-0574. 1999.

Lee T. -H., Huang T. -Y., Chen C.-H (2013). "The experimental study on biogas power generation enhanced by using waste heat to preheat inlet gases." *Journal of Renewable Energy* 50 (2013) 342-347.

Md. Ehsan and N. Naznin. (2004). "Performance of a Biogas Run Petrol Engine for Small Scale Power Generation." *Journal of Energy & Environment* 4 (2005) 1-9.

Mihic, S. (2004). "Biogas Fuel For Internal Combustion Engines."

Oh, T. H., Pang, S. Y., Chua, S. C. (2010). "Energy policy and alternative energy in Malaysia: *Issues and challenges for sustainable growth.*" *Renewable and Sustainable Energy Reviews* 14: 1241-1252.

Osario, F. and Torres, J. C. Biogas Purification from Anaerobic Digestion in a Wastewater Treatment Plant for Biofuel Production. *Renewable Energy* 2009;34: 2164-71.

Pundir, B. P, (2010). *IC Engines: Combustion and Emissions*. Slough, United Kingdom: Alpha Science International Ltd.

Porpatham, E., Ramesh, A., Nagalingam, B. "Investigation on the effect of concentration of methane in biogas when used as a fuel for a spark ignition engine." *Fuel* 87(8-9): 1651-1659.

Razbani, O., Mirzamohammad, N., Assadi, M. (2011). "Literature review and road map for using biogas in internal combustion engines.pdf."

Shashikantha.; Parikh, P.P. (1999). Spark ignition producer gas engine and dedicated compressed natural gas engine-Technology development and experimental performance optimization. SAE Paper.1999-01-3515.

Shekarchian, M.; Moghavvemi, M.; Mahlia, T. M. I.; Mazandarani, A. (2011). "A review on the pattern of electricity generation and emission in Malaysia from 1976 to 2008." *Renewable and Sustainable Energy Reviews* **15**(6): 2629-2642.

Surata, I. W.; Nindhia, T. G. T.; Atmika, I. K. A.; Negara, N. K. P.; Putra, I. W. E. P. (2014). "Simple Conversion Method from Gasoline to Biogas Fueled Small Engine to Powered Electric Generator." *Energy Procedia* 52: 626-632.

Wayne, W. S.; Clark, N. N.; Atkinson, C. M. (1998). A parametric study of knock control strategies for a bi-fuel engine. SAE Paper. 980895.

CHAPTER 7

APPENDIX

Appendix 1

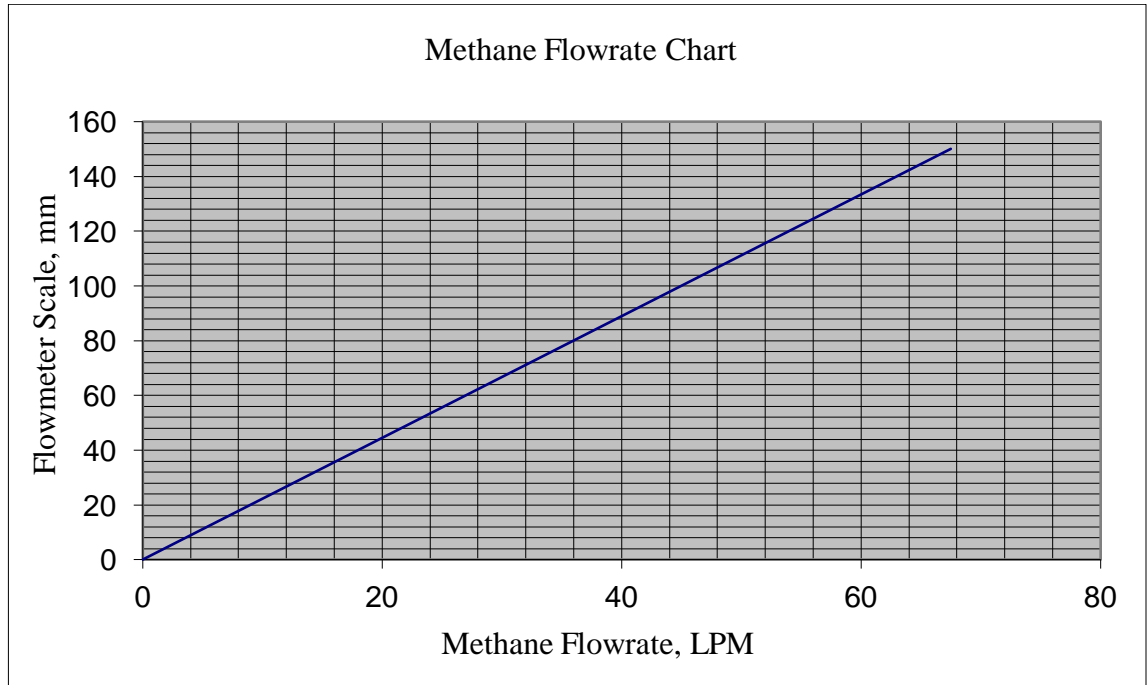

Source: MOX-Linde Gases Company (2015)

Appendix 2

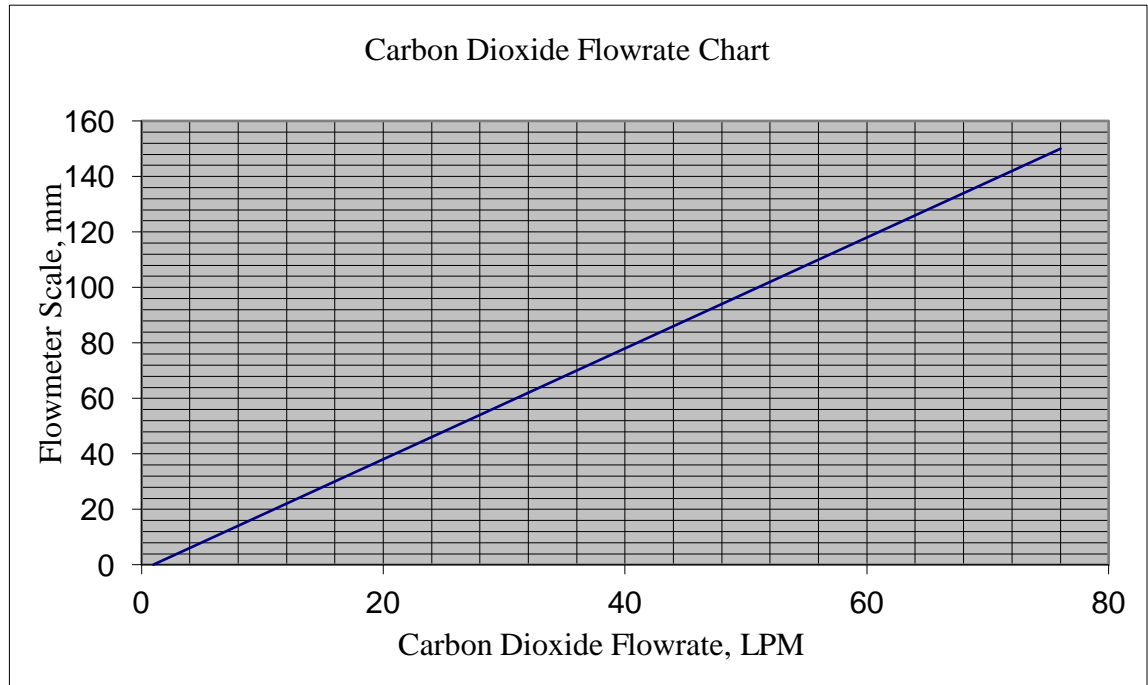

Source: MOX-Linde Gases Company (2015)