

# **Comparative Study of Different Coil Geometries for Wireless Power Transfer**

By

Lau Kevin

16392

Dissertation submitted in partial fulfilment of  
the requirements for the  
Degree of Study (Hons)  
(Electrical and Electronic Engineering)

JANUARY 2016

Universiti Teknologi PETRONAS  
Bandar Seri Iskandar  
31750 Tronoh  
Perak Darul Ridzuan

CERTIFICATION OF APPROVAL

**Comparative Study of Different Coil Geometries for Wireless Power Transfer**

By

Lau Kevin

16392

A project dissertation submitted to the  
Electrical and Electronic Engineering Programme  
Universiti Teknologi PETRONAS  
in partial fulfilment of the requirement for the  
BACHELOR OF ENGINEERING (Hons)  
(ELECTRICAL AND ELECTRONIC)

Approved by,

---

(Dr. Mohd Fakhizan Bin Romlie)

UNIVERSITI TEKNOLOGI PETRONAS  
TRONOH, PERAK  
JANUARY 2016

## CERTIFICATION OF ORIGINALITY

This is to certify that I am responsible for the work submitted in this project, that the original work is my own except as specified in the references and acknowledgements, and that the original work contained herein have not been undertaken or done by unspecified sources or persons.

---

LAU KEVIN

## ABSTRACT

Inductive coupling wireless power transfer is using time-varying resonant magnetic coupling to transfer the power from the transmitting coil to receiving coil through the air gap for various application such as charging up electric vehicles. However, the main issue is that the design of the coils have led to low mutual inductance and coupling coefficient which will lower the power efficiency as the distance of air gap increases. Therefore, this research is mainly studying and comparing the design of transmitting and receiving coil such as the geometries of the coils in order to investigate the power efficiency, mutual inductance, coupling coefficient and magnetic flux. In this research, a finite element method (FEM) software, Ansoft Maxwell is used to investigate and compare the performance of various designs of coils such as spiral planar coils, square planar coils and pentagon planar coils. In addition, prototypes have been built by using PCB planar coils in shape of spiral, square and pentagon in order to compare the results and performance from simulation. In terms of result, low mutual inductance and coupling coefficient are caused by the distance of air gap. When the distance of air gap is longer, the mutual inductance and coupling coefficient are lower for the three different of coils. And also, magnetic flux is also determined by the geometries of coil where it will affect the mutual inductance which influents the coupling coefficient and power efficiency. Finally, pentagon coil is the best coil among all coils in terms of performance since simulation and experiment result have the same trend. In the future, there will be more simulations and analysis on the other different design of coils.

## **ACKNOWLEDGEMENT**

First and foremost, I would like to thank Electrical and Electrical Department in Universiti Teknologi PETRONAS (UTP) for the great opportunity to carry out my research at UTP for 8 months. This period of time has been very fruitful and has provided great experience for me in my life.

I would like to express heartiest gratitude towards Dr. Mohd Fakhizan Bin Romlie for offering such interesting Final Year Project title for me, and even for being cooperative and supportive of my decision for further improvement and assistance in my research. I was able to have a better understanding about my job requirement and project scope.

I would like to express my greatest appreciation to Zaifulrizal bin Zainol from Univerisit Kuala Lumpur at Majung, Perak for his guidance and discussion throughout this FYP1 and FYP2. He has been very supportive in my pursuit for knowledge and his wisdom has definitely helped me a lot in my project.

Next, deepest thanks to my friends especially Victor Goh, Billy Wong, Justin Lee, and Mr Zuraimie from power system lab. Their willingness to spare me their time and generosity to support me both spiritually and mentally is very much appreciated.

Last but not least, I wish to thank my family members for their unparalleled contribution and support, both morally and financially throughout my life such as love, motivation and encouragement. They are my pillar of strength and without them; I would not be who I am today.

## TABLE OF CONTENT

CERTIFICATION OF APPROVAL .....	ii
CERTIFICATION OF ORIGINALITY .....	iii
ABSTRACT .....	iv
ACKNOWLEDGEMENT .....	v
TABLE OF CONTENT .....	vi
LIST OF FIGURES .....	viii
LIST OF TABLE .....	x
CHAPTER 1 INTRODUCTION .....	1
1.1 BACKGROUND.....	1
1.2 PROBLEM STATEMENT.....	2
1.3 OBJECTIVES.....	3
1.4 SCOPE OF STUDY.....	3
1.5 RELEVANCY OF PROJECT .....	4
1.6 FEASIBILITY OF PROJECT .....	4
CHAPTER 2 LITERATURE REVIEW .....	6
2.1 INDUCTIVE COUPLING AND CAPACITIVE COUPLING .....	6
2.2 RESONANT FREQUENCY AND MAGNETIC RESONANT COUPLING .....	7
2.3 LEAKAGE INDUCTANCE AND MUTUAL INDUCTANCE .....	8
2.4 RESONANT CIRCUIT TOPOLOGIES.....	11
2.5 TRANSMITTING AND RECEIVING COIL .....	12
2.5.1 MATERIAL OF COIL.....	12
2.5.2 COIL .....	13
2.5.3 ADDING CORE.....	14
2.6 RECENTNESS AND RELEVANCY OF LITERATURE .....	15
CHAPTER 3 METHODOLOGY .....	18
3.1 RESEARCH METHODOLOGY .....	18
3.2 PROJECT REVIEW.....	19
3.2.1 PROPOSED GEOMETRY OF COILS .....	19
3.3 TOOLS .....	20
3.4 PROJECT ACTIVITY .....	21
3.4.1 KEY MILESTONE .....	21

3.4.2 PROJECT FLOW CHART FOR FYP 1 & FYP2.....	22
3.5 GANTT CHART .....	23
3.5.1 GANTT CHART FOR FYP1 .....	23
3.5.2 GANTT CHART FOR FYP 2 .....	24
CHAPTER 4 RESULT & DISCUSSION .....	26
4.1 OVERVIEW .....	26
4.2 COIL DESIGN .....	26
4.2.1 Simulation Coil Design .....	27
4.2.2 Experimental Coil Design (Prototype).....	31
4.3 RESULT .....	33
4.3.1 Simulation Result .....	33
4.3.2 Experimental Result .....	37
4.3.3 Comparison between Experimental and Simulation result .....	43
CHAPTER 5 CONCLUSION AND RECOMMENDATION.....	45
5.1 CONCLUSION.....	45
5.2 RECOMMENDATION .....	45
REFERENCES.....	47

## LIST OF FIGURES

Figure 1: Topologies for resonant circuit[15] .....	8
Figure 2: Diagram of transmitting coil and receiving coil with parameters[1].....	10
Figure 3: Method to measure series and parallel inductance by LCR meter [17].....	10
Figure 4: Litz wire.....	13
Figure 5: Rectangular with planar coil.....	13
Figure 6: The methodology of coils geometries for wireless power transfer .....	18
Figure 7: Key Milestone.....	21
Figure 8: FYP 1 and 2 flow chart.....	22
Figure 9: The combination of key milestone and project activities .....	25
Figure 10: 3-D Spiral planar coil design in Ansoft Maxwell.....	27
Figure 11: Side view of spiral planar coil .....	27
Figure 12: Plane View of spiral planar coil .....	28
Figure 13: 3-D Square planar coil design in Ansoft Maxwell .....	28
Figure 14: Side view of square planar coil.....	28
Figure 15: Plane view of square planar coil.....	29
Figure 16: 3-D Pentagon planar coil design in Ansoft Maxwell .....	29
Figure 17: Side view of pentagon planar coil .....	29
Figure 18: Plane view of pentagon planar coil.....	30
Figure 19: Printed circuit board (PCB) coil designs .....	31
Figure 20: Prototype fabricated by Perspex, screws, nuts and wires.....	31
Figure 21: Overall system for wireless power transfer .....	32
Figure 22: Pentagon coils with 1cm air gap distance tested in experiment .....	32
Figure 23: The graph of coupling coefficient against air gap distance (SIM) .....	35
Figure 24: The graph of mutual inductance against air gap distance (SIM).....	35
Figure 25: Magnetic flux of spiral planar coil (SIM).....	36
Figure 26: Magnetic flux of square planar coil (SIM).....	36
Figure 27: Magnetic flux of pentagon planar coil (SIM).....	37
Figure 28: The prototype experiment setup .....	38
Figure 29: Graph of output power against air gap distance (EXP).....	40
Figure 30: Graph of power efficiency against air gap distance (EXP) .....	41
Figure 31: Graph of coupling coefficient against air gap distance (EXP) .....	42
Figure 32: Graph of mutual inductance against air gap distance (EXP).....	42



Figure 33: Graph of coupling coefficient against air gap (SIM Vs. EXP)..... 43

Figure 34: Graph of mutual inductance against air gap (SIM Vs. EXP) ..... 43

## LIST OF TABLE

TABLE I: The comparison between inductive coupling and capacitive coupling .....	6
TABLE II: Summary of parameters for each topology .....	12
TABLE III: Findings about shape of coil and its advantages .....	14
TABLE IV: The physical parameters of PCB coils .....	19
TABLE V: Gantt Chart of Final Year Project 1 .....	23
TABLE VI: Gantt Chart of Final Year Project 2 .....	24
TABLE VII: Resistance and Inductance of windings.....	33
TABLE VIII: Simulation result of spiral planar coil in Ansoft Maxwell.....	33
TABLE IX: Simulation result of square planar coil in Ansoft Maxwell.....	34
TABLE X: Simulation result of pentagon planar coil in Ansoft Maxwell .....	34
TABLE XI: Input and output power for spiral planar coil.....	39
TABLE XII: Mutual inductance and coupling coefficient for spiral planar coil.....	39
TABLE XIII: Input and output power for square planar coil .....	39
TABLE XIV: Mutual inductance and coupling coefficient for square planar coil....	39
TABLE XV: Input and output power for pentagon planar coil .....	40
TABLE XVI: Mutual inductance and coupling coefficient for square planar coil....	40

# CHAPTER 1

## INTRODUCTION

### 1.1 BACKGROUND

Nowadays, there are many researches regarding inductive coupled power transfer (ICPT) studying and developing around the world. There are two approaches for charging a battery which are conductive coupling and inductive coupling. Apparently, ICPT is bringing many advantages since the conventional method is using the direct wire to conduct the electricity from a power source, which causes a lot of inconveniences and hazard especially electric shock or electrocution [1]. ICPT is actually a wireless charging method or inductive coupling method by utilizing the electromagnetic field from the primary coil to induce voltage and current in the secondary coil without any direct wire connection. It means that there are actually two identical or different electric coil separated with each other within a distance, and one is transferring the power to another one through the air gap between them. Therefore, one of the electric coils is installed to power source which could be Alternating Current (AC) or Direct Current (DC). Hence, wireless charging is more convenient and efficient than the conventional method. Thus, ICPT has been developed to implement widely in many fields such as mobile phone, electric vehicle, and others [1]–[3]. Yet, ICPT is still under research and development because the leakage inductance is higher than the magnetizing inductance which is mutual inductance [4].

Nikola Tesla, who was Serbian American electrical engineer, can be considered as the father of ICPT since he invented the alternating current and electromagnetic theory including transformer, Tesla coil and others. Definitely ICPT concept is coming from his theory based on the working principle of transformer. Tesla tower was one of his projects used to transmit the power through the air over a large distance widely. Eventually, his project was banned and not supported due to some consideration such as harmful radiation to human body and interference or damage to

the electrical equipment. This concept is using the time-varying electromagnetic field to transfer the data or the power and classified into two techniques which are non-radiation and radiation. Non-radiation technique is using time-varying magnetic field from primary coil to induce the power through resonant frequency in a short distance, while the radiation technique is using electromagnetic field such as microwave or radiowave to transmit the power from transmitter to the receiver.

Theoretically, there will be the mutual inductance and leakage inductance involved during the power transfer. Authors from [5] stated that the mutual inductance is totally dependent to leakage inductance, meanwhile playing an important role to determine coupling coefficient that affect the performance for power transfer. In the meantime, mutual inductance will be affected by the coil geometries as well. Therefore, mutual inductance and coupling coefficient are one of crucial factors that influent the wireless power transfer system. On the other hand, printed circuit board (PCB) windings for coils is recently well-known and being used mostly in electronic system which is using low power according to [6]. It is because the material is tiny, lighter and low-cost which is suitable for electronic gadgets. As for high power transfer, it is advisable to use copper wire or Litz wire windings instead of using PCB windings due to high current and high voltage during the power transfer [7].

## **1.2 PROBLEM STATEMENT**

Since the two windings of coils are physically separated by the air gap, this air gap will cause the low coupling efficient and large leakage inductance which results in poor efficiency. And also, when the leakage inductance increases, the mutual inductance will decrease. From that, the efficiency will be decreased since mutual inductance is directly proportional to the power transfer at the load as shown as Eq. (8). It means that the leakage inductance between transmitting and receiving coil is the power loss in the power transmission. Therefore, the problem statement that is to be addressed in this research is the transmitting and receiving coil design which has mainly contributed towards significant losses in the wireless power transfer.

### **1.3 OBJECTIVES**

. The objectives of this project are:

- To investigate and compare various coil geometries of transmitting and receiving coils in terms of performances
- To perform the simulation using FEM software in order to analyse the performance of the various design.
- To compare mutual inductance and coupling coefficient between experiment and simulation.

### **1.4 SCOPE OF STUDY**

Scope of study is used to achieve and reflect the purposes and target mentioned above. A lot of related research and analysis have been done to verify that the knowledge regarding to this paper is fully utilised and applied. In order to achieve the advancement of technology, a better understanding and critical thinking are playing an important and essential role to solve the problem in this research. There is a few of study and job scope need to be carried out and analysed including the following:

- Study on the electromagnetic theory and working principle of transformer
- Study on relationship, effect and definition between inductance, self inductance and mutual-inductance
- Study on the resonant frequency and the topology of resonant circuit
- Study on the how and what shape and type of core will improve the efficiency
- Study on the electric car requirement such as input voltage, current and power
- Study and understand the functions of each parts in wireless charging
- To simulate a electromagnet inductive power transfer with using Ansoft Maxwell software

## **1.5 RELEVANCY OF PROJECT**

For this project, author would like to focus on the electric vehicle cordless charging system. According to the objective of this project, it is mainly to improve the power efficiency in high power transmission and enhance the air gap between primary windings and secondary winding. This purpose is very crucial and critical since there had been many researches about leakage inductance and power loss in high power. This research is going to help a lot in the future, as the electricity is one of important and essential commodity in living life. Not only electric vehicle, this concept is able to be implemented and applied into other field such as wireless mobile phone charging, wireless power transmission line, home appliances and others. There are many benefit of having this wireless power transfer technology such as:

- Reduce wire direct connection
- Reduce cost and material
- Achieve Universal power standard due to no plug and socket required
- Electrical energy and power transfer anywhere (no restriction because of no cable required)
- Reduce untidiness concern
- Reduce accident such as cable wear off, wire burnt, electric shock

In a short, having this concept working in real life makes a better life and brings numerous of conveniences without any restriction.

## **1.6 FEASIBILITY OF PROJECT**

This research is given a time frame to finish the activity and job scope as stated as Gantt Chart FYP1, Gantt Chart FYP2, and key milestone. This project is going to design the transmitting and receiving coil within the time frame so that it can achieve the target based on the objective of this project. It is very vital to design and simulate the final best design for the transmitting and receiving coil effectively and efficiently within FYP1. It is because the mini prototype is recommended to be implemented and built in FYP2, even though it is considered as an optional credit if time permit.

Hence, this will be making the every process in this project feasible and achievable in this Final year project (FYP).

## CHAPTER 2

### LITERATURE REVIEW

A number of research papers, journal and books have been read to analyse and investigate this ICPT project. The aim of this literature review is to understand and study theory and working principle behind wireless charging by using transmitter and receiver coil. At the end, this project is able to be verified and proven by the simulation by using Ansoft Maxwell.

#### 2.1 INDUCTIVE COUPLING AND CAPACITIVE COUPLING

It is still controversial between using inductive coupling and capacitive coupling power transfer. Apparently, there are so many researches regarding inductive coupling power transfer due to some reasons, whereas capacitive is not that hot topics in wireless power transfer currently, yet there were a few studies[3] about it. Definitely there are advantages and disadvantages between both techniques.

**TABLE I: The comparison between inductive coupling and capacitive coupling**

Descriptions	Inductive Coupling	Capacitive Coupling
Power transfer medium	Magnetic Field	Electric Field
Input signal frequency required	High [8]	Low [8]
Ability of penetration through metal	No [3]	Yes [3]
Eddy Current loss in metal	Yes [4]	No [3]
Interference	Electromagnetic [3], [9]	Electric field [3]
Coupling signal (when the distance between each plate or coil increase)	Decrease [10]–[13]	Decrease [8]
Noise	No	Yes [8]

**TABLE I** compares the differences between inductive coupling and capacitive coupling. For the electric vehicle charging, a very high operating frequency input is required [1]. Therefore, inductive coupling is more suitable and much better to be utilised. For electric vehicle wireless charging system, there are no worries about penetration through metal since there is no metal between transmitting coil and



receiving coil. Even though eddy current loss and skin effect exist when there are some metals around inductive coupling, shielding and using Litz wire had been recommended by other research to reduce the eddy current and skin effect. Last but not least, there will be noise created in capacitive coupling, but not in inductive coupling since noise could be a power loss factor. In a conclusion, in order to further improve the electric vehicle wireless charging system, inductive coupling is recommended to be further investigated in this project.

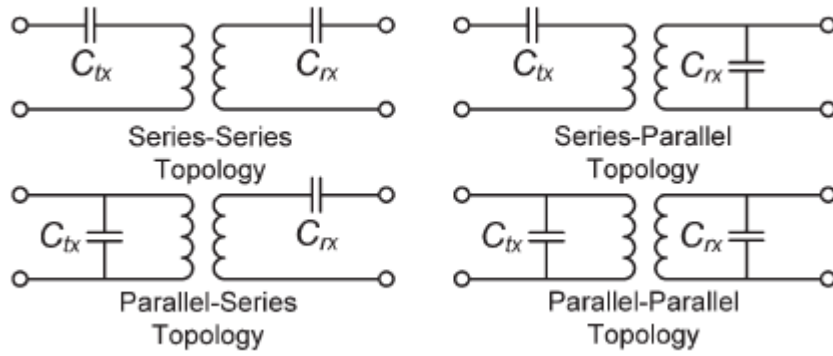
## 2.2 RESONANT FREQUENCY AND MAGNETIC RESONANT COUPLING

Resonance is the situation occurs where a system can produce maximum amplitude when there is external factor such as force to drive it. Similar to the resonant frequency, it is defined as the frequency which will produce maximum result at the output when the natural frequency is same with it. According to [10], the resonant frequency will be achieved when the reactance from the primary coil (transmitter) is totally identical to the reactance from the secondary coil (receiver). It means that the capacitance and inductance at the transmitting coil and receiving coil have to be calculated and designed to match with the resonant frequency used in the system. Witricity system which is now developing wireless charging has lead the technology to prove that suitable resonant frequency can make the coupling coefficient,  $k$  high between 0.7 and 0.9 [14]. On the other hand, [4] had suggested that the frequency between 10kHz and 100kHz would be the suitable frequency in term of cost since it will create skin effect as increasing the frequency in high power transfer.

The relationship between resonant frequency,  $f$  with capacitance,  $C$  and inductance,  $L$  is given by:

$$f = \frac{1}{2\pi\sqrt{LC}} \quad (1)$$

It shows that three elements are dependent to each other. Eq. (1) is important in generating the resonant frequency by designing the capacitance and inductance value. According to the Series-Series Topology in **Figure 1**, desired capacitance value can be controlled and designed since the transmitting coil and receiving coil act as constant inductance.



**Figure 1: Topologies for resonant circuit[15]**

### 2.3 LEAKAGE INDUCTANCE AND MUTUAL INDUCTANCE

During the wireless power transmission between primary coil and secondary coil, there must be some leakage such as leakage inductance. Meanwhile, mutual inductance can be caused by the magnetic flux from primary coil cutting the secondary coil to induce the voltage and current on the secondary coil. Sometimes, the leakage inductance would be higher than mutual inductance in the loosely coupled system, which will reduce the magnetizing flux [1], [4]. According to the Neumann's formula, there are a few equations that are related to mutual inductance such as:

$$M_{21} = N_1 N_2 P_{12} \quad (2)$$

Where  $M_{21}$  is the mutual inductance where primary coil induced voltage to secondary coil,  $N_1$  is the number of turns of primary coil,  $N_2$  is the number of turns of secondary coil, and  $P_{12}$  is the permeance/ permeability between the space by flux.

There is a relationship between mutual inductance and coupling coefficient,  $k$  following to the equation below.

$$M_{21} = k\sqrt{L_1 L_2} \quad (3)$$

Where  $L_1$  is the inductance of primary coil and  $L_2$  is the inductance of secondary coil.

In order to derive and understand the further formula that will be used in this paper, a fundamental basic formula of inductance of a coil in a solenoid is a must. This general equation had been derived by using Maxwell equation previously.

$$L = \frac{\mu_0 \mu_r N^2 A}{l} \quad (4)$$

Where  $L$  is the self inductance of the coil,  $N$  is the number of turns in a solenoid,  $\mu_0$  is the magnetic constant in the air,  $\mu_r$  is the relative permeability of the material of the solenoid,  $A$  is the cross section area of the coil, and  $l$  is the length of coil.

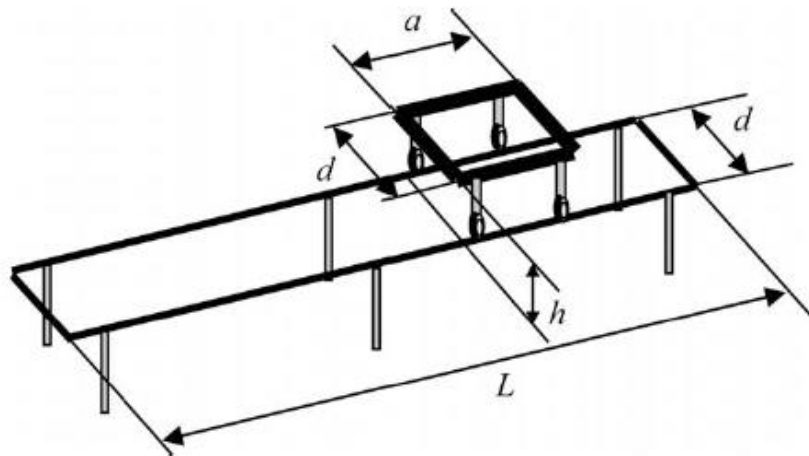
According to [1], [16], they proposed to use rectangular shape of coil as the transmitting and receiving as shown as **Figure 2**, therefore the equation of calculating and designing self inductance is different with the equation of inductance in circular shape. Eq. (5) must be using with parameters as shown as **Figure 2**.

$$L = \frac{\mu_0 N^2}{\pi} \left[ \left[ d \ln \frac{2Ld}{R(L + \sqrt{L^2 + d^2})} \right] + \left[ L \ln \frac{2Ld}{R(L + \sqrt{L^2 + d^2})} \right] - 2 \left[ d + L - \sqrt{d^2 + L^2} \right] + \frac{L+d}{4} \right] \quad (5)$$

Where  $R$  is the radius of the winding coil and determined by the Eq. (6) below.

$$R = \sqrt{\frac{NS}{\pi}} \quad (6)$$

Where  $S$  is the diameter of the coil used.



**Figure 2: Diagram of transmitting coil and receiving coil with parameters[1]**

On the other hand, in the research [17] regarding to the analysis of contactless transformers with ferrite core using resonant converter, suggested that there are some equation being used in order to find out the mutual inductance and leakage inductance by measuring the series inductance and parallel inductance with impedance analyser (LCR meter).

$$M = L_m \left( \frac{N_2}{N_1} \right) \quad (7)$$

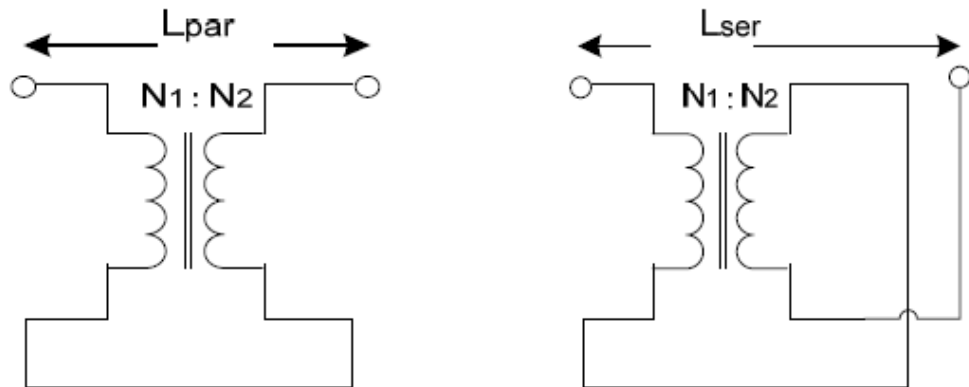
$$L_{11} = L_1 - L_m \quad (8)$$

$$L_{22} = L_2 - L_m \left( \frac{N_2}{N_1} \right) \quad (9)$$

$$L_{ser} = L_1 + L_2 + 2M \quad (10)$$

$$L_{par} = L_1 + L_2 - 2M \quad (11)$$

Where  $M$  is the mutual inductance,  $L_m$  is the magnetizing inductance,  $L_1$  is the self-inductance of primary coil,  $L_2$  is the self-inductance of secondary coil,  $L_{11}$  is the leakage inductance on the primary coil,  $L_{22}$  is the leakage inductance of secondary coil,  $L_{ser}$  is the series inductance between primary and secondary coil and  $L_{par}$  is the parallel inductance between primary and secondary coil.



**Figure 3: Method to measure series and parallel inductance by LCR meter [17]**

## 2.4 RESONANT CIRCUIT TOPOLOGIES

There are four topologies as shown as **Figure 1** above, being suggested by [4], [15] such as Series-Series, Series-Parallel, Parallel-Series and Parallel-Parallel which can help to achieve resonant frequency. However, according to the resonant circuit topology by [15], it stated that the parallel-parallel topology at the transmitter and receiver will be the best solution to achieve the resonant magnetic, whereas [1], [18] had been using series-series topology for their projects. Adding one capacitor at both transmitting coil and receiving coil will compensate the total reactance with inductor at each side, since capacitor reactance is negative reactance which will produce negative power through the theory. When the inductor reactance is equal to capacitor reactance, the system will produce maximum power since it has become purely resistive. On the other hand, [16] stated and analysed that each of the topology has its own advantage and disadvantages depends on the condition and situation of the project, meanwhile SS compensation had been used for that research due to its low copper mass required and convenience on control wiring. Moreover, SS or SP is better and advantageous in high power transmission if using high operating frequency, meanwhile PS and PP are recommended to utilize at low power level device like wireless phone charging system because of the current required is low and improvement in distance when using low frequency such as 11kHz [16]. Each of the topology has different total impedance formula since their capacitor arrangement is different with each other. However, author was using SS topology for this project since it involved high power transmission in the simulation and future prototype.

Total impedance formula in Series-Series topology:

$$Z_T = \left[ R_1 + j \left[ L_1 \omega - \frac{1}{C_1 \omega} \right] \right] + \frac{\omega^2 M^2}{\left[ R_2 + R_L + j \left[ L_2 \omega - \frac{1}{C_2 \omega} \right] \right]} \quad (12)$$

Where  $R_1$  is the resistance in first inductor (coil),  $R_2$  is the resistance in second inductor (coil),  $R_L$  is the load resistance,  $M$  is mutual inductance

At the end, power transfer on the load must be calculated in order to calculate the power efficiency.

$$P_2 = \frac{\omega M^2}{L_2} I_p^2 \quad (13)$$

According to the **TABLE II**, Series-Series topology is best and suitable to this project since this research is regarding wireless high power transmission.

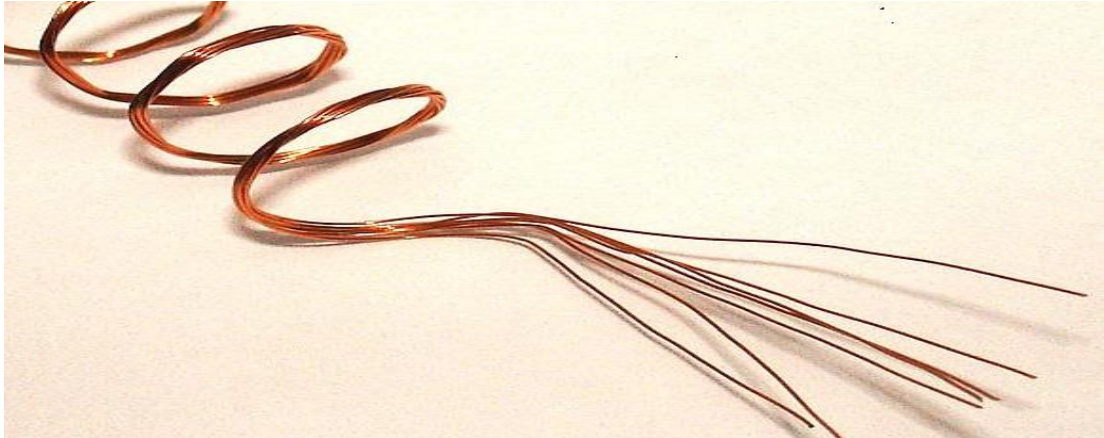
**TABLE II: Summary of parameters for each topology**

Parameters	SS	SP	PS	PP
Primary Capacitance and Magnetic Coupling Coefficient	Independent	Dependent	Dependent	Dependent
Primary Capacitance and Load	Independent	Dependent	Dependent	Dependent
Reactance at primary and secondary (at resonant frequency)	No	Yes	Yes	Yes
Copper mass required (kg)	34.6	36.2	45	43
Voltage Source characteristic	High / High	High / Low	Low / High	Low / Low
Current Source characteristic	Low / Low	Low / High	High / Low	High / High
Mutual Inductance (uH)	11.88	3.46	2.97	0.49
Frequency (kHz)	18	18	11	12

## 2.5 TRANSMITTING AND RECEIVING COIL

### 2.5.1 MATERIAL OF COIL

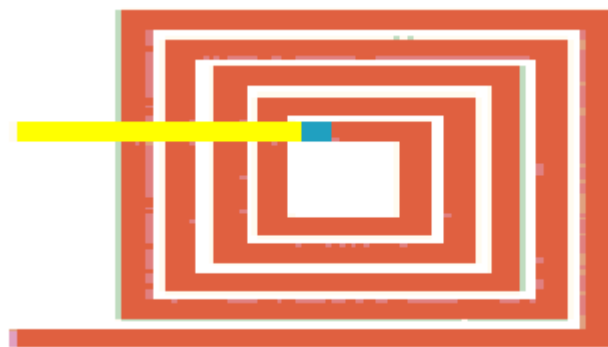
As author mentioned above, there must be skin effect and proximity effect losses which make the resistance in the conductor increasing during the power transmission. As the operating frequency of AC goes high, the skin effect and proximity effect losses will be higher. In order to reduce such negative effects which totally affect the power efficiency to drop, there is a wire called Litz wire being recommended by [4], [15], [16], [19]. It is a wire which contains two or more stranded and twisted copper wire wound together in order to lower the degree of skin effect and proximity effect eventually. Therefore, it is important to use Litz wire in this project instead of using single core copper wire.



**Figure 4: Litz wire**

### **2.5.2 COIL**

The shape of the coil is also playing crucial role in the high power transmission. It is because different shape will generate various patterns of magnetic field and flux. Sometimes, the shape of coil may not generate a stable and suitable magnetic flux which will affect the power efficiency in wireless power transmission. There was a remarkable research done by [12] which analysed and proved that a spiral with planar coil without any core will have a better coupling efficiency than the rounded winding of coil, and it even own less resistance. In addition, this statement is also agreed by [16],[1], but a rectangular with planar coil had been implemented and tested due to its tolerance of misalignment since project involved was dealing with electric car battery charging system. Generally, spiral coil is mainly for phone charging[9], [12] while rectangular coil will be focusing on the high power transmission especially for electric vehicle [16].



**Figure 5: Rectangular with planar coil**

**TABLE III: Findings about shape of coil and its advantages**

Reference Number	Shape of coil	Description of work	Advantages/Disadvantage
[14], [20]	Rectangular Spiral coil	Compare the shape of coil with traditional magnetic coil	1)Power transferred and efficiency is higher 2)total efficiency = 80.9% & coupling efficiency = 88.4%, total power = 11.8W
[12]	Circular Spiral coil	Study about the effect of different windings of primary coil and secondary coil	1)Circular spiral windings on PCB has better magnetic coupling than traditional rounded wire 2)Dimension of coil determine the gap of distance & coupling effect
[16], [1]	Rectangular Flat Spiral coil	Study about the overall design of ICPT system for electric vehicle	1)Improve the power transfer capability 2)Higher tolerance for misalignment
[11]	Circular spiral coil	Study about design of electric vehicle and switching frequency	1)Gap or misalignment increase, coupling coefficient decreases
[21]	Rectangular Spiral coil	Study about the effect between multiple transmitters and multiple receivers	1)Using multiple transmitting coil in parallel, can improve received power with better coupling efficiency

### 2.5.3 ADDING CORE

Adding a core would bring so many function and advantage in wireless transmissions. For example, adding a ferrite core can just improve the coupling efficiency and in result of higher the power transmissions [4], [10], [16]. In addition, it can also function for shielding purpose, minimize the exposure to human and reduce interference to the electronic devices. However, that is another suggestion that adding a E-core within the windings will help to shape the magnetic field in terms of reduce the leakage inductance which will help to improve the power transfer



efficiency [10], [13]. In terms of magnetic field shaping technique and reduce leakage flux, there is also another way like adding a ferromagnetic material with low conductivity on the paramagnetic material with high conductivity. It is suggested to put an aluminium plate or ferrite polymer composite sheet or ferrite-aluminium plate below the coil [4], [9], [16], [19] to increase the coupling factor and reduce the leakage flux and even eddy current. Overall, adding a core or sheet is recommended for magnetic field shaping and other purposes.

## **2.6 RECENTNESS AND RELEVANCY OF LITERATURE**

From [4], Kunwar Aditya and his other members from Concordia University at Canada had done a research in 2014 to review the basic required consideration when it comes to design the cordless electric vehicle charging system. This research paper has helped to remind and inspire author since it is very similar to author's project. There are important design parameters such as skin effect and proximity effect which will be deteriorated by high frequency, field-shaping method, compensation technique which include the four topologies, and control strategies for such system.

There was a research done by Yee Kang Yung [2] in 2014 as well, which demonstrated his wireless power transmission by using solar. This paper did make author to understand how the things working principle of each component throughout wireless power transfer through air gap without any medium. In this research, the geometry of coil and operating frequency are quite crucial since its prototype has succeeded to transmit the power and energy from a primary coil to secondary coil to light up a LED within a distance of 4cm. At the end, it is recommended to improve its power efficiency and increase distance of air gap.

It is followed by a research [10] done by Ho Chi Young and his teammate in 2011 in Durham University. This research had talked a contactless charging for electric vehicle in a large air gap which has the points that author need to refer to. And it is able to develop an inductive coupler which can transfer power up to 3kW for the electric vehicle by using the technique of high frequency, design of core, number of turn ratio which affect the performance. Eventually, the distance problem is the main

factor which causes a greater leakage inductance if the distance of air gap increases, meanwhile the air gap distance is determined by the height of the electric vehicle.

Last but not least, this paper [1] which was done by Juan Luis Villa and his colleague in 2009 in University of Zaragoza located in Spain, is very relevant to author because it is the research that author focus on and needs to improve its power efficiency and distance air gap. It had studied about the best compensation topology for the resonant circuit and the operational frequency to maximize the power efficiency. During the experiment, they managed to build a 5kW prototype to run for the simulation and testing. It concluded that it is difficult to determine the parameter like frequency and design of the coil. It is because the frequency depends on the distance of coils, the load, and the shape of current. And it is better to control the frequency so that the gap can be increased by 20 % and misalignment increased by 30 %.

According to [5], there are quite a few of methods to calculate the mutual inductance such as Maxwell formulas, Grover's methods, FEA and Neumann's integrals. In author's previous works, Neumann's formula had been utilized in double integration to calculate the mutual inductance which will maximize the efficiency of the inductive coupling power transfer. In addition, Grover's method can provide useful and accurate mutual inductance of the coils, but it becomes complicated and tedious when it is implemented in various shapes of coils, even in misalignment condition. In this research, a generalized mutual inductance computation method was designed and presented by using the discretization of the flux distribution on the secondary coil where Biot-Savart law is utilized. This mutual inductance computation method is proved to be applicable for any geometries of coil in any misalignment such as vertical, lateral, planar, angular. In terms of result, the experiment result and analytical result shows less than 10% percentage difference, where it is due to physical limitation from experiment.

A very similar work [6] had been done to calculate the mutual inductance in the PCB planar coil by implementing Neumann formula. Neumann formula was derived from the magnetic vector potential and Faraday's law. Due to its complexity, it is advisable and limited for simple geometries with straight track such as hexagon shape which was implemented in that research instead of using circular shape. This

paper also focused on the misalignment in x, y, and z-direction which will produce different mutual inductance. An experiment was built by using PCB planar windings in hexagon shape to measure the mutual inductance by using secondary voltage and current in order to validate the mutual inductance from analytical calculation. As a result, there is less than 5% percentage difference between experimental result and analytical result.

## CHAPTER 3

### METHODOLOGY

#### 3.1 RESEARCH METHODOLOGY

The aim of this research is to focus on mainly on the coil shape of transmitting coil and receiving coil to study the power efficiency, mutual inductance, coupling efficient over varying the distance air gap in wireless power transmissions. Furthermore, this project is also mainly using the FEM software, Ansoft Maxwell to design and simulate the design of both coils. In this section, a methodology will be proposed for this research. In the end, result from experiment (prototype) and simulation (Ansoft Maxwell) will be compared and analyzed to make a conclusion.

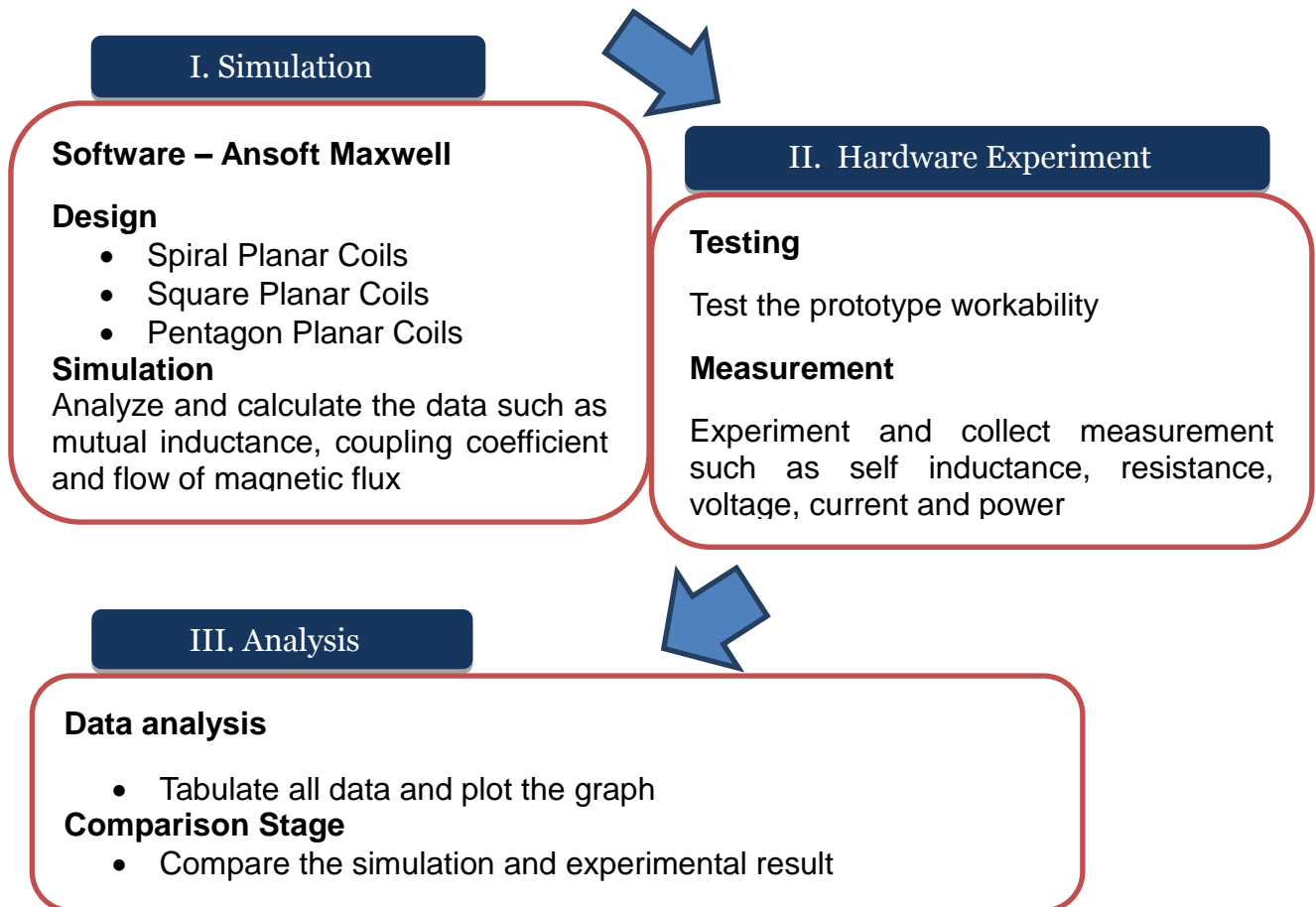


Figure 6: The methodology of coils geometries for wireless power transfer

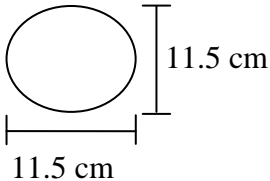
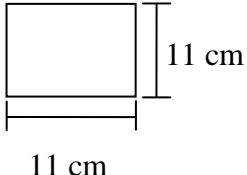
### 3.2 PROJECT REVIEW

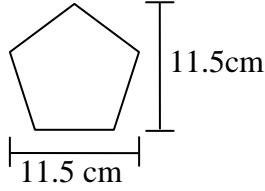
As author mentioned before, this research will be fully concentrated on the transmitting coil and receiving coil. Therefore, a new proposed design must be designed and simulated to prove whether it can enhance the power efficiency and distance of air gap. According to some researches [1], [4], [10], [16], [22] which are quite similar to author's research, therefore it is good to focus on these references to fulfil the consideration of the overall wireless charging system. However, other research still also can give a lot of ideas on how to improve the design of coil.

#### 3.2.1 PROPOSED GEOMETRY OF COILS

As mentioned in section of objective, this research will only focus on studying how performance is among different shapes of coils. Therefore, the proposed geometry of coils will be spiral planar, square planar and pentagon planar coil. From there, author is able to investigate which types of coil can produce the highest power efficiency, mutual inductance and coupling coefficient through experiment. In order to verify and prove the experimental result, author will utilize the finite element method software Ansoft Maxwell which is able to design the spiral planar, square planar and pentagon planar coil with the same parameter as the prototype. In the end, author will be able to analyse and compare the experimental result and simulation result to make a conclusion for this research.

**TABLE IV: The physical parameters of PCB coils**

<p><b>PRIMARY COIL</b></p>		<ul style="list-style-type: none"> <li>- Thickness = 0.1 cm</li> <li>- No. Turns = 15</li> <li>- Separation Between Traces = 0.3 cm</li> </ul>
		<ul style="list-style-type: none"> <li>- Thickness = 0.15 cm</li> <li>- No. Turns = 14</li> <li>- Separation Between Traces = 0.3 cm</li> </ul>

		<ul style="list-style-type: none"> <li>- Thickness = 0.15 cm</li> <li>- No. Turns = 14</li> <li>- Separation Between Traces = 0.2 cm</li> </ul>
<b>SECONDARY COIL</b>	Same as Primary Coil	

### 3.3 TOOLS

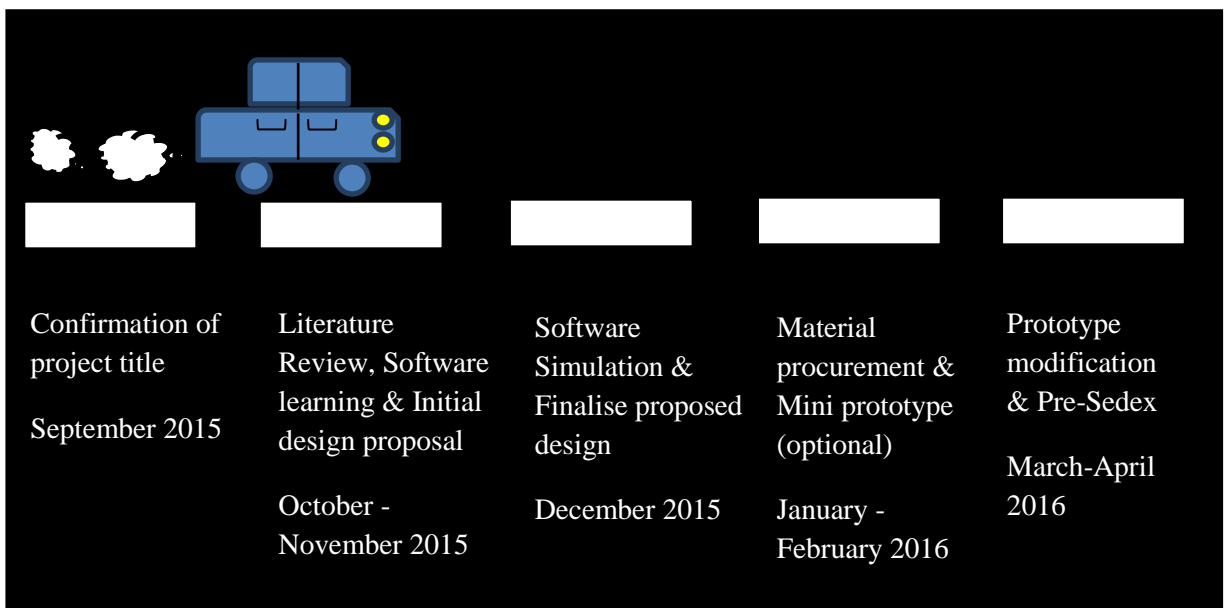
- Ansoft Maxwell  
Proposed coils design and simulation was done by Ansoft Maxwell.
  
- Proteus Simulator  
The circuit design simulation was modification and tested by Proteus Simulator.
  
- Microsoft Word 2010  
The report was prepared and written by using Microsoft Word 2010.
  
- Microsoft Excel 2010  
The graph and table was prepared by using Microsoft Excel 2010.
  
- Microsoft Power Point 2010  
The presentation was designed and prepared by Microsoft Power Point 2010.
  
- Experiment tools  
DC power supply, Power meters, LCR meter, Lab computer, alligator clips, banana cable, and AC power supply

### 3.4 PROJECT ACTIVITY

This part of paper is going to describe what author needs to do throughout the Final Year Project course. It consists of the project key milestone, project flow chart and Gantt chart which indicates the details of the activity and targets that author needs to achieve.

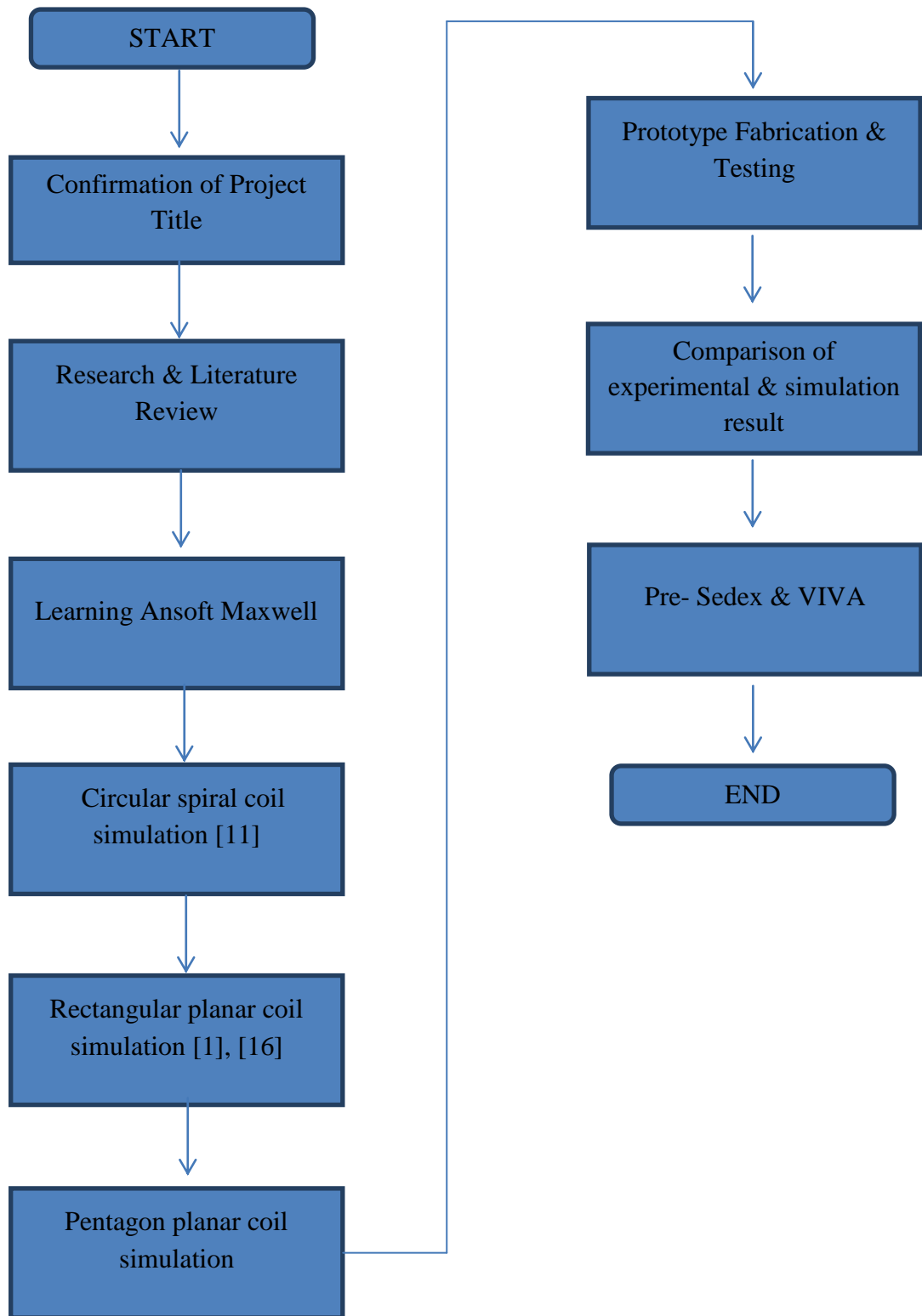
#### 3.4.1 KEY MILESTONE

This project contains a few of key milestone need to be completed through this Final Year Project as shown as the **Figure 7** below. To be exact, this Final Year Project (FYP) was divided into two semesters which consists of Final Year Project 1 (FYP1) and Final Year Project 2 (FYP2) respectively. As for the first key milestone, the confirmation of project title had been take place in the end of September 2015. Then, it is followed by the literature review, software learning and initial design proposal which took about 2 months where it was from October until November 2015. The next crucial task is finalising the proposed design and software simulation which is in December 2015. After that, proposed design modification and material procurement will be the next target where drops on January and February 2016. Last but not least, mini prototype design will fall on March and April 2016.



**Figure 7: Key Milestone**

### 3.4.2 PROJECT FLOW CHART FOR FYP 1 & FYP2



**Figure 8: FYP 1 and 2 flow chart**



### 3.5 GANTT CHART

#### 3.5.1 GANTT CHART FOR FYP1

**TABLE V: Gantt Chart of Final Year Project 1**

Activities	Week NO/Date													
	1	2	3	4	5	6	7	8	9	10	11	12	13	14
Selection of Project title	■	■												
Preliminary Research Work		■	■	■	■									
Attend FYP Talks		■	■	■	■	■	■							
Proposed Design				■	■	■								
Submission of Extended Proposal							★							
Learning Ansoft Maxwell							■	■	■	■	■	■	■	■
Proposal Defence								■	■					
Spiral planar coil Design									■	■	■	■	■	■
Square planar coil Design									■	■	■	■	■	■
Pentagon planar coil Desgin									■	■	■	■	■	■
Proposed Design Simulation									■	■	■	■	■	■
Proposed Design Modification									■	■	■	■	■	■
Preparation of Interim Report							■	■	■	■	■	■	■	■
Submission of Interim Draft Report													★	
Submission of Interim Report														★



Process



Key Milestone

### 3.5.2 GANTT CHART FOR FYP 2

TABLE VI: Gantt Chart of Final Year Project 2

Activities	Week NO/Date														
	1	2	3	4	5	6	7	8	9	10	11	12	13	14	15
Spiral planar coil Design	■	■	■	■	■	■	■	■	■						
Square planar coil Design	■	■	■	■	■	■	■	■	■						
Pentagon planar coil Desgin	■	■	■	■	■	■	■	■	■						
Proposed Design Simulation	■	■	■	■	■	■	■	■	■						
Proposed Design Modification	■	■	■	■	■	■	■	■	■						
Progress Report								★							
Material Procurement (optional)	■	■													
Circuit Design Simulation (optional)	■	■	■												
Circuit Implementation and Testing (optional)			■	■	■	■	■	■	■						
Building Mini Prototype (optional)			■	■	■	■	■	■	■						
Testing, Troubleshooting & Modification			■	■	■	■	■	■	■						
Comparison between simulation results	■	■	■	■	■	■	■	■	■	■					
Pre-Sedex											★				
Preparation of Draft Final Report									■	■	■	■			
Submission of Draft Final Report													★		
Submission of Dissertation (Soft Copy)														★	
Submission of Technical Paper														★	
Viva															★



Process



Key Milestone

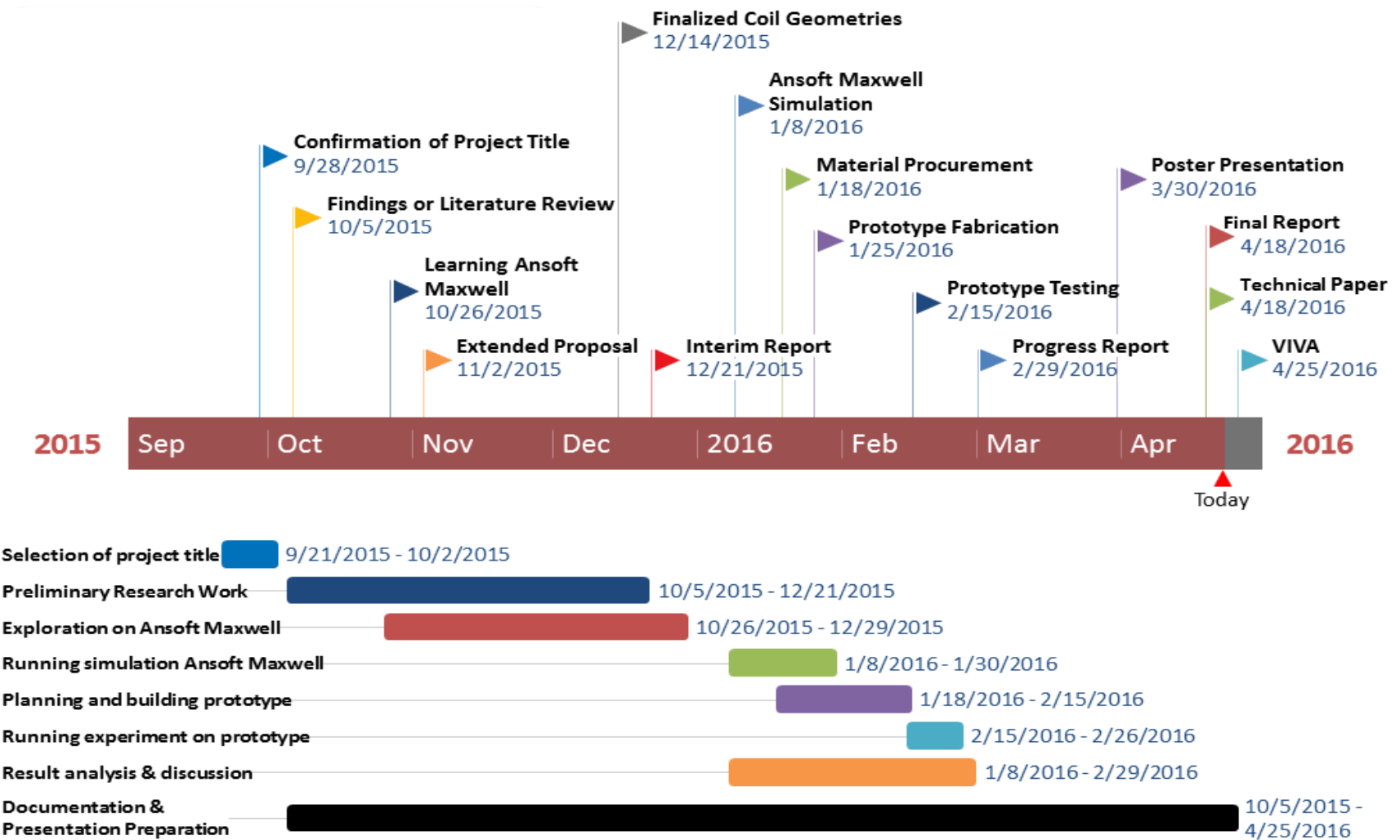


Figure 9: The combination of key milestone and project activities

## **CHAPTER 4**

### **RESULT & DISCUSSION**

#### **4.1 OVERVIEW**

This section is to demonstrate the result of each design of transmitting and receiving coil for wireless power transfer. The finalized design and the simulation had been done by using Ansoft Maxwell which is finite element analysis in order to find out the effect of mutual inductance, coupling coefficient and magnetic flux by varying the distance of air gap (z-shift). From that, author is able to perform the simulation by Ansoft Maxwell successfully since it is new software to the author. Based on the result and data, the author is able to analyse what the effect spiral planar coil, square planar coil and pentagon planar coil will contribute to the mutual inductance and coupling coefficient. However, it is a good start to explore this new software in order to understand the basic and fundamental.

On the other hand, prototype had been fabricated by using printed circuit board (PCB) winding as the primary and secondary coil in the shape of spiral, square and pentagon. Besides, a primary circuit which is used as the DC to AC converter while secondary circuit will be used as AC to DC converter. Next, prototype was ran and tested in the experiment by varying over the distance air gap between transmitting and receiving coil. Finally the result was collected and calculated in order to do comparison with the simulation result.

#### **4.2 COIL DESIGN**

Like author mentioned, this project mainly focus on the transmitting and receiving coil design and study. According to the FYP flow chart shown at the previous section, author will use Ansoft Maxwell to simulate and design the different type of coil to such as variety of shape to look for the result. The coils's characteristics were designed by Ansoft Maxwell including the length of coil, width of coil, diameter of coil section, and other according to the actual parameters of the prototype. Meanwhile, author also fabricated the experimental coils (prototype) with the same parameter with the simulation coil design by using printed circuit board coil, perspec,

screw, nuts and others. For the information, the coil shapes being used for this project are spiral, square and pentagon planar coil which is using printed circuit board for fabrication. Both simulation and experimental coil designs will be designed by following the physical parameter which is stated as TABLE IV above.

#### 4.2.1 Simulation Coil Design

##### Spiral Planar Coil

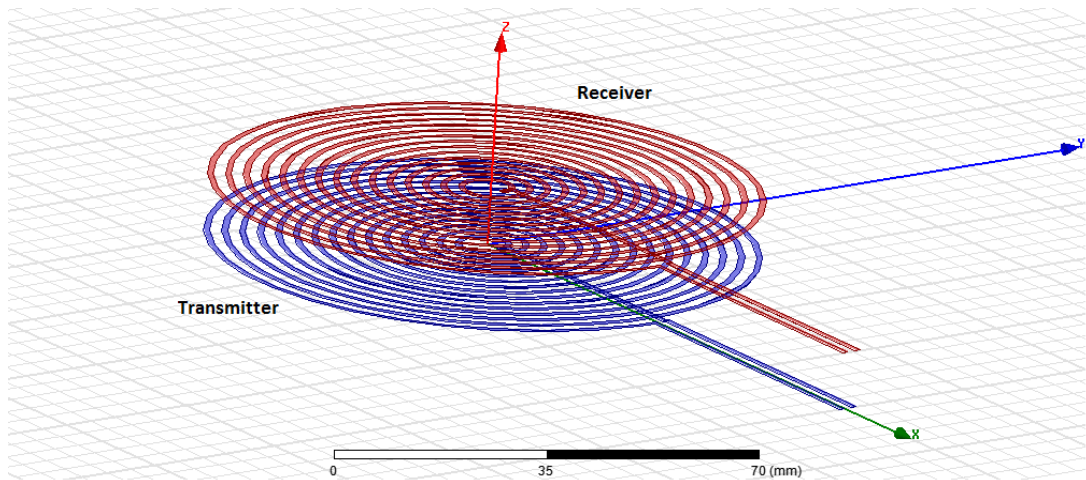


Figure 10: 3-D Spiral planar coil design in Ansoft Maxwell

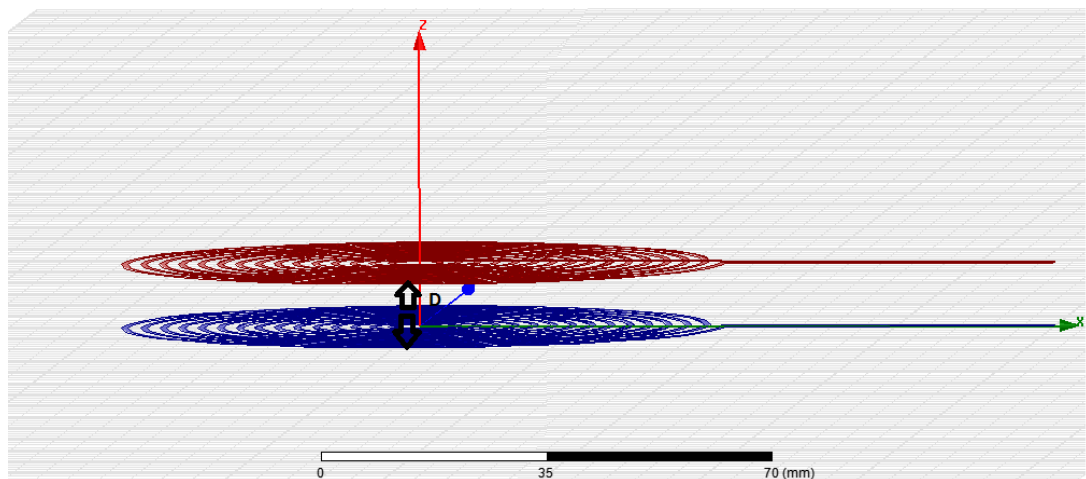
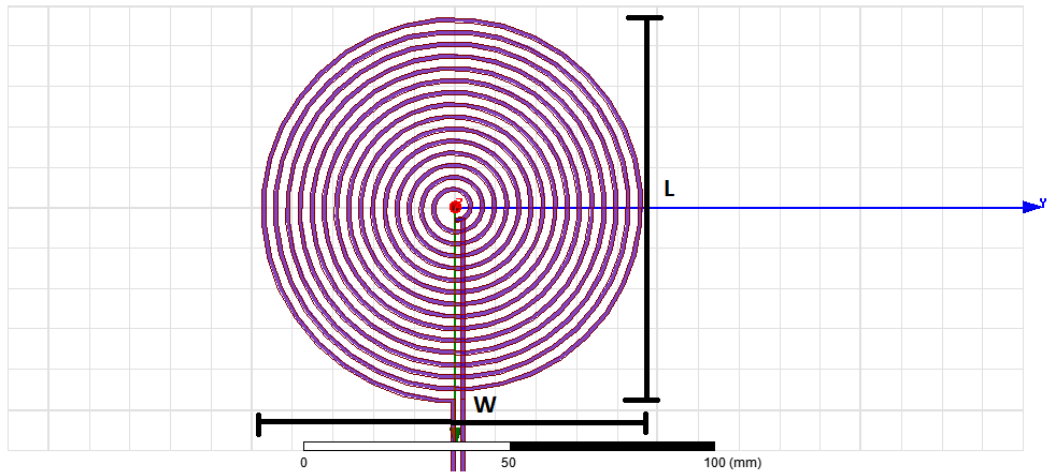
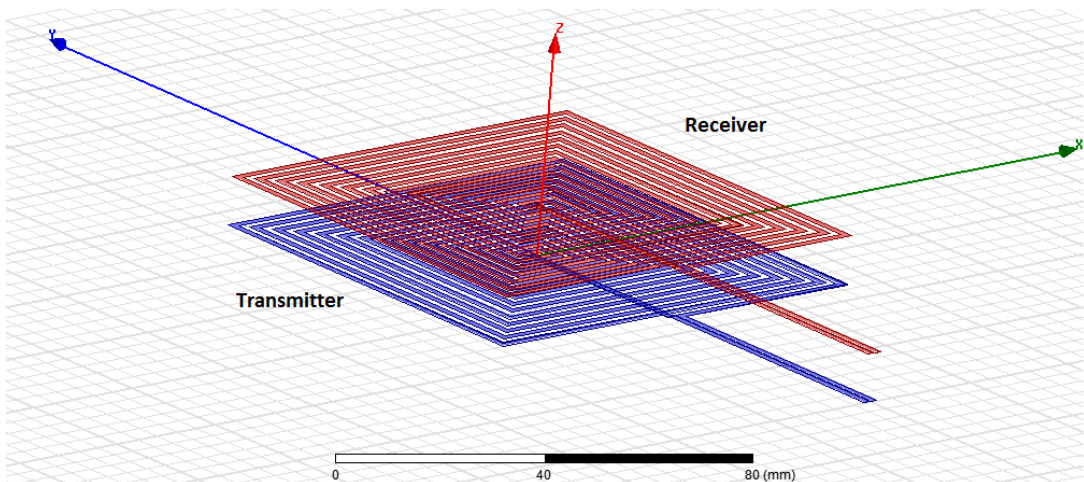


Figure 11: Side view of spiral planar coil

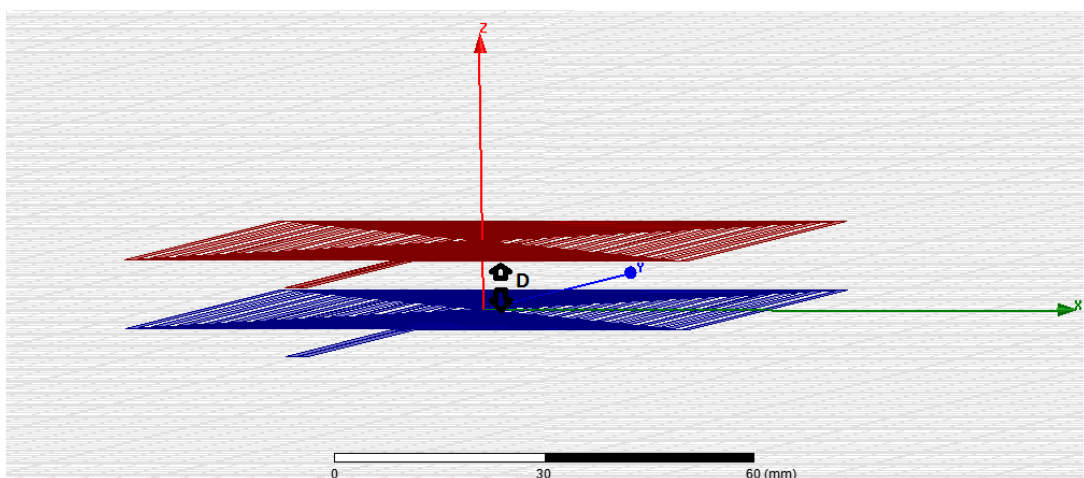


**Figure 12: Plane View of spiral planar coil**

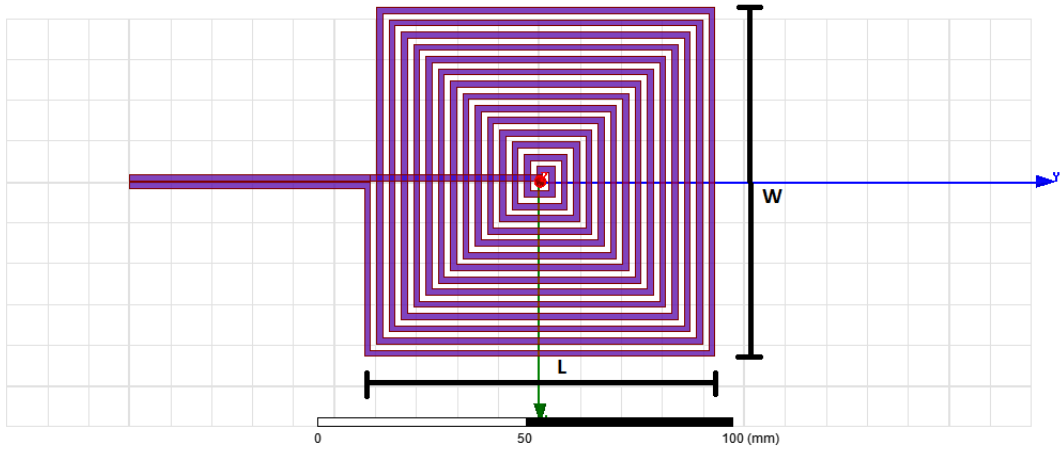
**Square Planar Coil**



**Figure 13: 3-D Square planar coil design in Ansoft Maxwell**

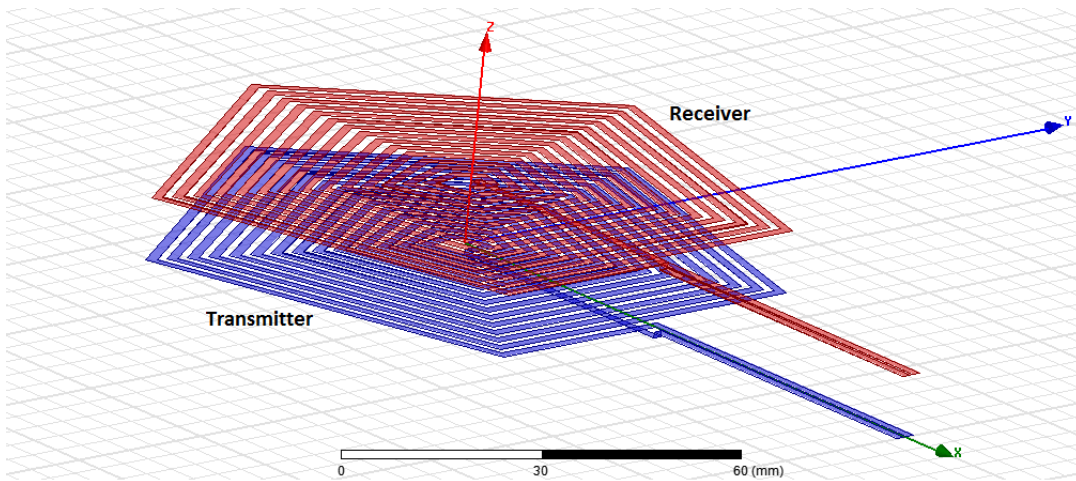


**Figure 14: Side view of square planar coil**

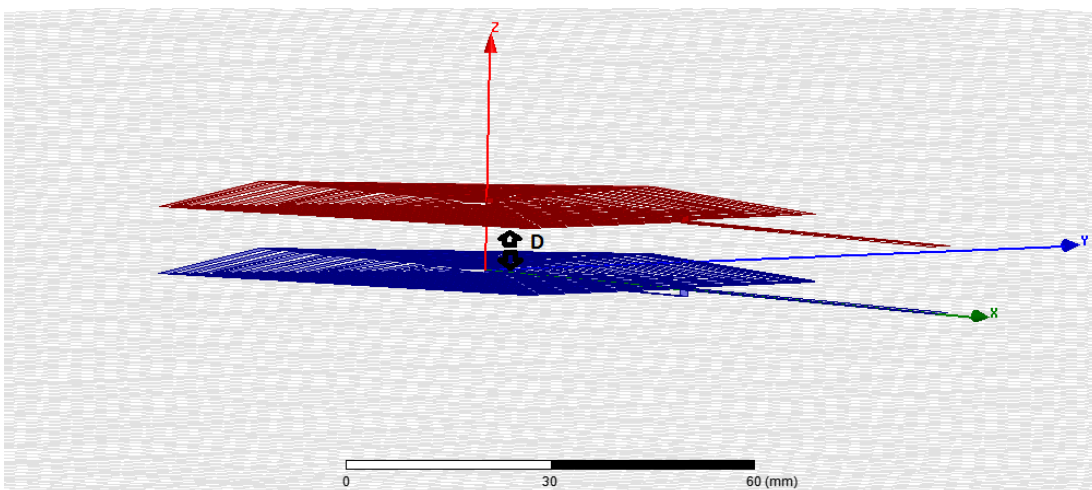


**Figure 15: Plane view of square planar coil**

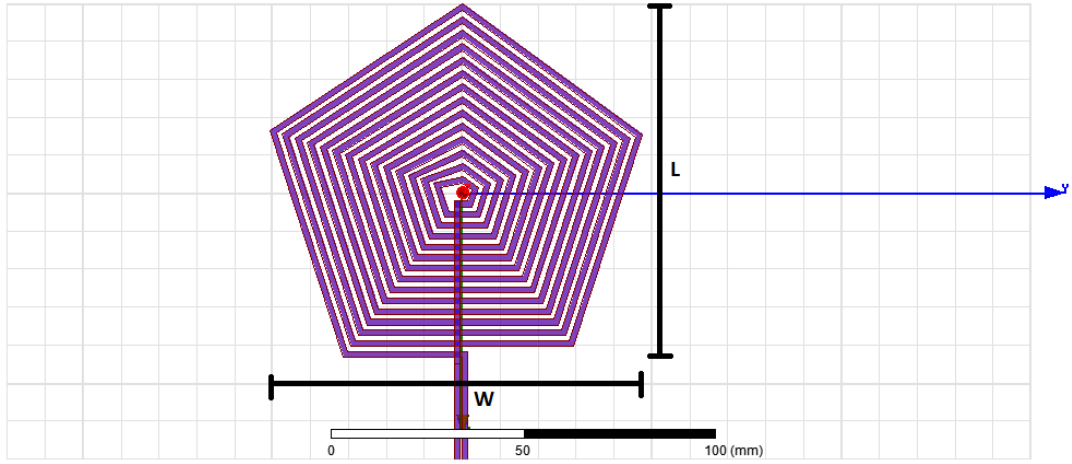
**Pentagon Planar Coil**



**Figure 16: 3-D Pentagon planar coil design in Ansoft Maxwell**



**Figure 17: Side view of pentagon planar coil**



**Figure 18: Plane view of pentagon planar coil**



#### 4.2.2 Experimental Coil Design (Prototype)

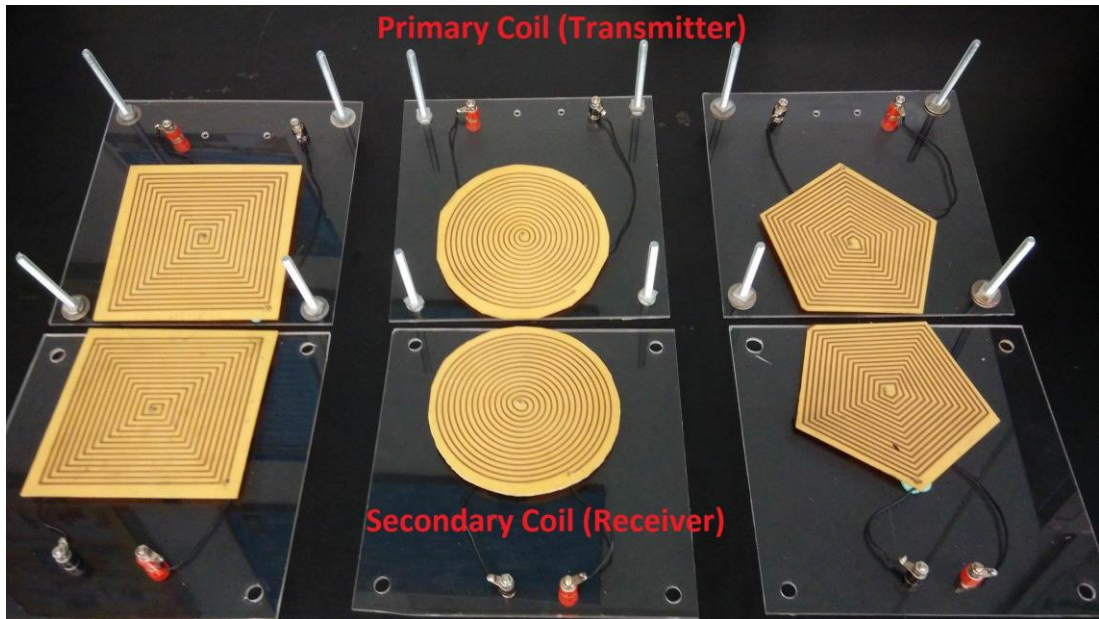


Figure 19: Printed circuit board (PCB) coil designs

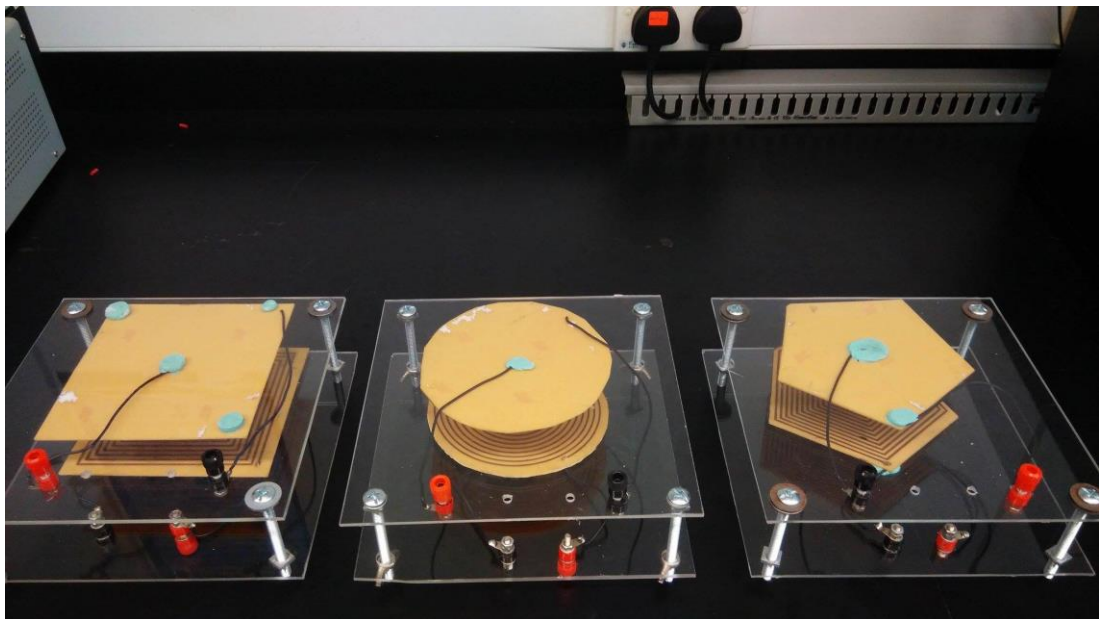


Figure 20: Prototype fabricated by Perspex, screws, nuts and wires

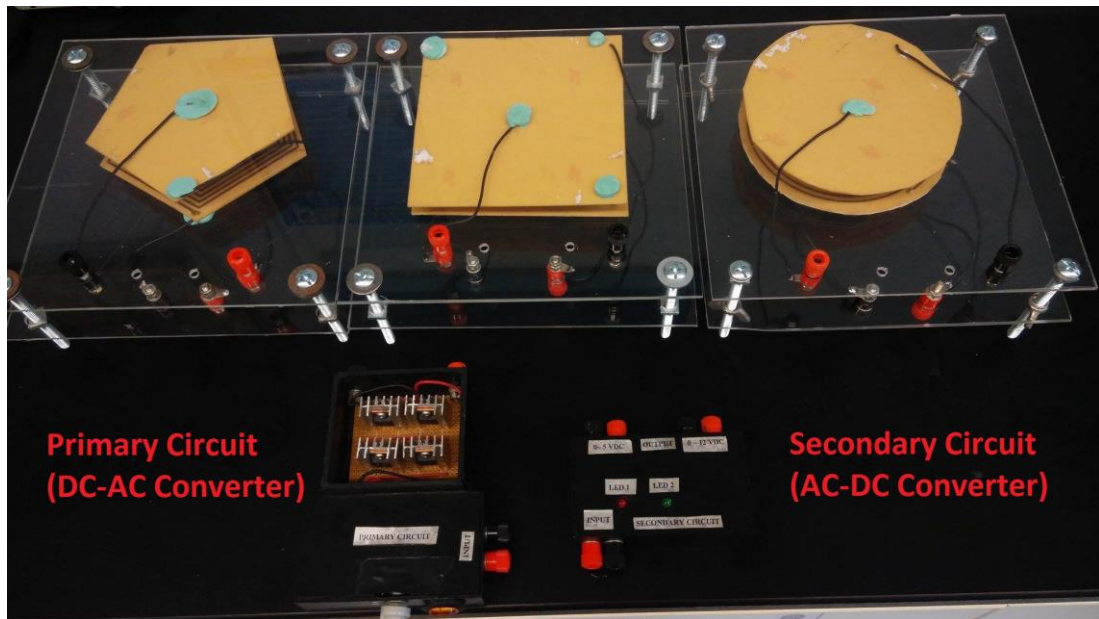


Figure 21: Overall system for wireless power transfer

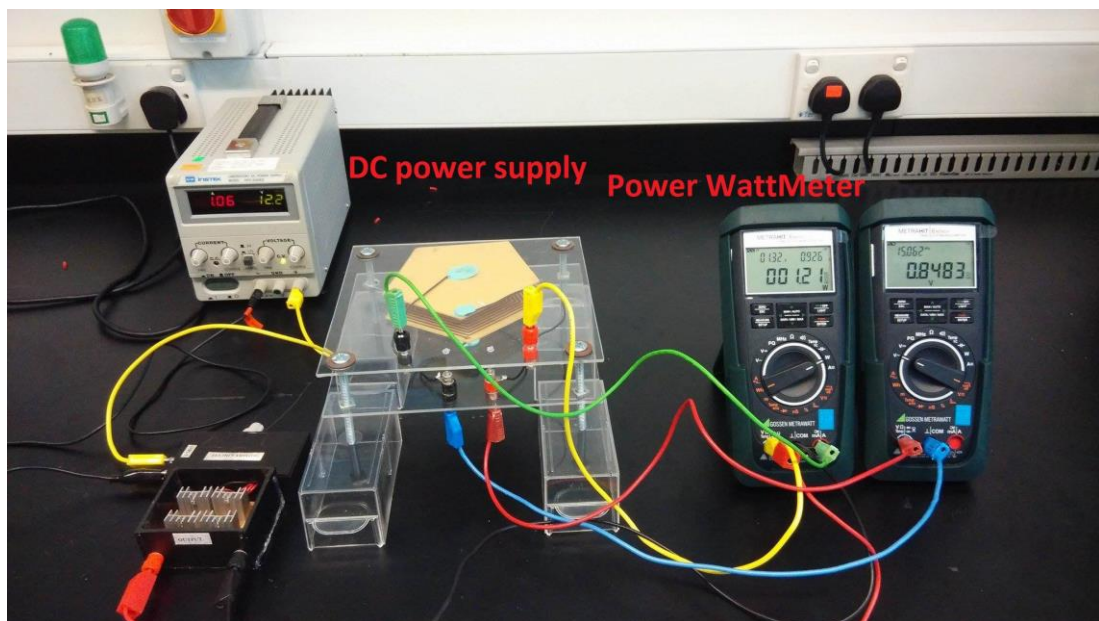


Figure 22: Pentagon coils with 1cm air gap distance tested in experiment

**TABLE VII: Resistance and Inductance of windings**

Coil	Resistance	Inductance
Spiral	<b>R1</b> = 1.60 $\Omega$	<b>L1</b> = 10.9 $\mu\text{H}$
	<b>R2</b> = 1.40 $\Omega$	<b>L2</b> = 10.1 $\mu\text{H}$
Square	<b>R1</b> = 1.40 $\Omega$	<b>L1</b> = 11.0 $\mu\text{H}$
	<b>R2</b> = 1.47 $\Omega$	<b>L2</b> = 10.7 $\mu\text{H}$
Pentagon	<b>R1</b> = 1.30 $\Omega$	<b>L1</b> = 10.1 $\mu\text{H}$
	<b>R2</b> = 1.40 $\Omega$	<b>L2</b> = 10.1 $\mu\text{H}$

### 4.3 RESULT

In this section, simulation coils and experimental coils had been designed to collect the result such as mutual inductance, and coupling coefficient due to the distance of air gap. From that, a comparison between simulation and experimental result can be done to differentiate the difference and look for the factors if necessary. Hence, the results and data had been collected and tabulated in table form while graphs were also plotted.

#### 4.3.1 Simulation Result

On the other hand, simulation and analysis had been set up for the three coil design in order to find out the mutual inductance, coupling coefficient and magnetic flux over the air gap distance which is in range of 4cm by using finite element method – Ansoft Maxwell. In the simulation, an automatic adjustment of air gap distance in z-direction had been with running the simulation in the meantime. From there, result had been collected and tabulated in the plotted graphs below.

#### Spiral Planar Coil

**TABLE VIII: Simulation result of spiral planar coil in Ansoft Maxwell**

Air Gap Distance [cm]	Coupling Coefficient	Mutual Inductance [ $\mu\text{H}$ ]
1	0.221913545	0.8911954
1.5	0.15262783	0.6430236
2	0.108628161	0.4649702
2.5	0.07746895	0.327564
3	0.054022675	0.2187499

3.5	0.034766702	0.1269611
4	0.016774389	0.04613862

### Square Planar Coil

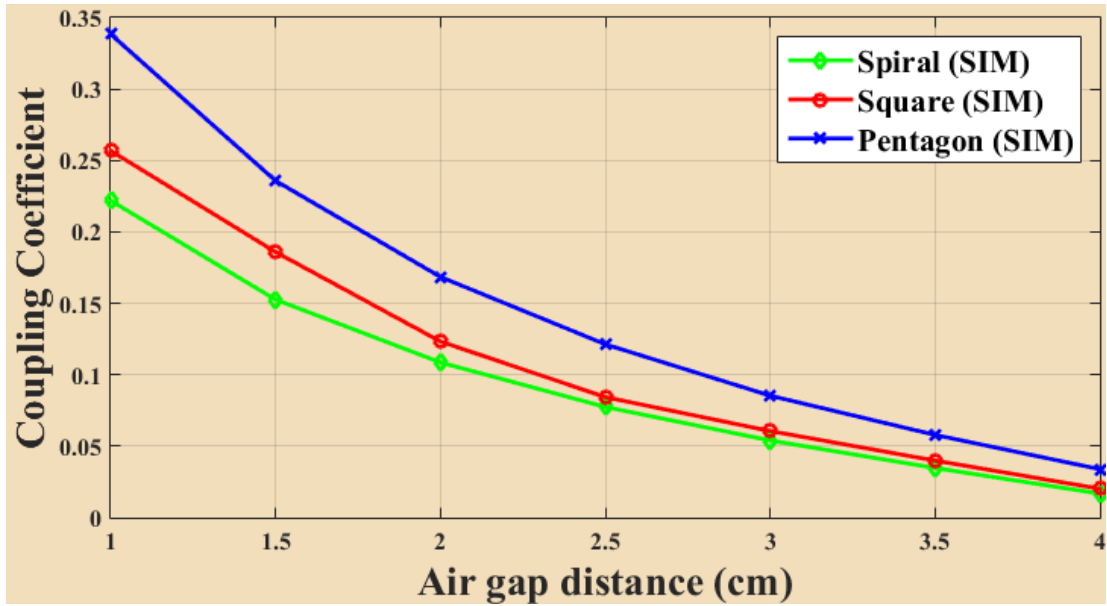
**TABLE IX: Simulation result of square planar coil in Ansoft Maxwell**

Air Gap Distance [cm]	Coupling Coefficient	Mutual Inductance [uH]
1	0.256798693	1.380235
1.5	0.185930309	1.048839
2	0.12330321	0.706754
2.5	0.08436147	0.4865471
3	0.060614305	0.2657394
3.5	0.039916888	0.1303162
4	0.020199577	0.084102

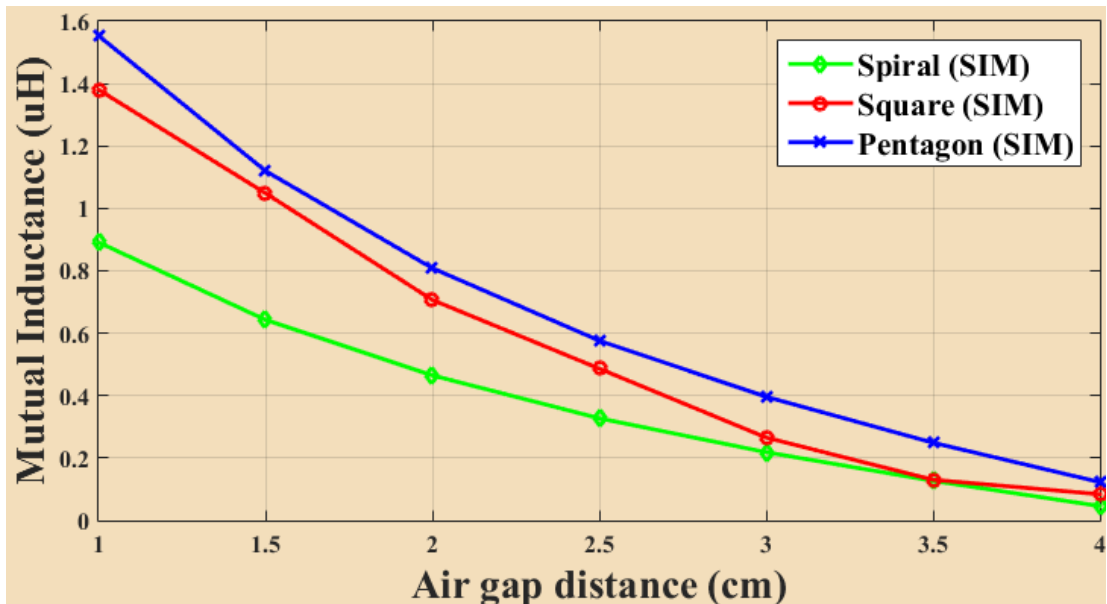
### Pentagon Planar Coil

**TABLE X: Simulation result of pentagon planar coil in Ansoft Maxwell**

Air Gap Distance [cm]	Coupling Coefficient	Mutual Inductance [uH]
1	0.338404436	1.553266
1.5	0.235785275	1.120221
2	0.168489723	0.8085064
2.5	0.121333924	0.5762167
3	0.08536073	0.396421
3.5	0.057895385	0.2491819
4	0.033887611	0.1227654



**Figure 23:** The graph of coupling coefficient against air gap distance (SIM)



**Figure 24:** The graph of mutual inductance against air gap distance (SIM)

According to the **Figure 23** and **Figure 24**, author is able to observe that the mutual inductance and coupling coefficient truly decreases as same as the theory behind. As the distance of air gap increases, the mutual inductance and coupling coefficient drops. By comparing the three coils, pentagon planar is having the highest mutual inductance and coupling coefficient. Meanwhile, square planar comes to second and spiral planar is the last place.

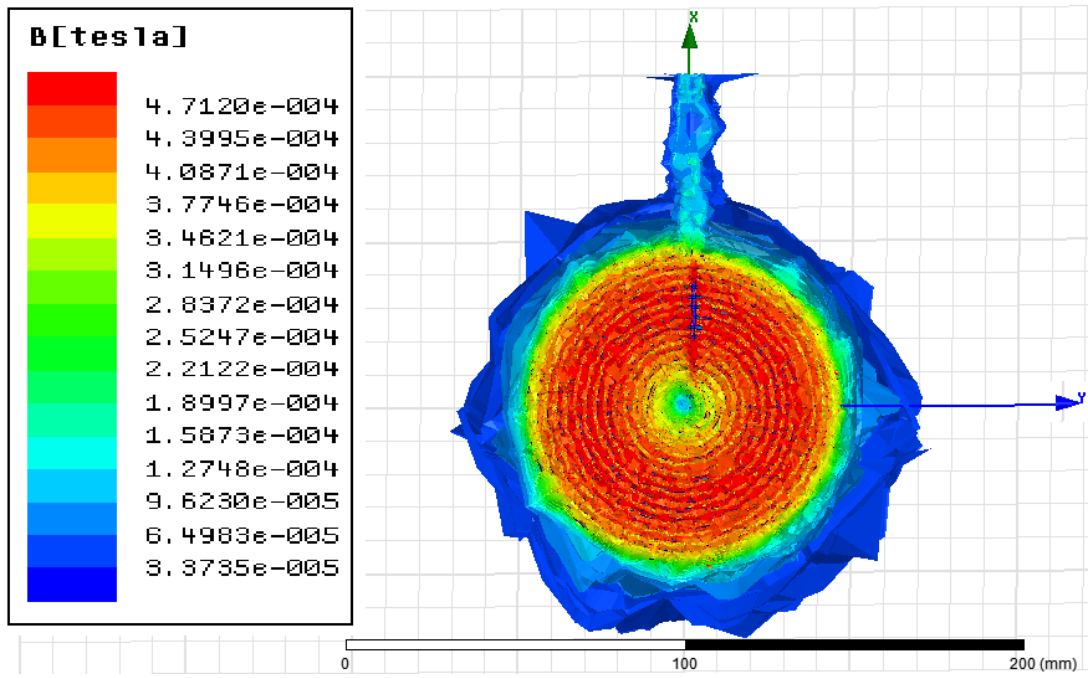


Figure 25: Magnetic flux of spiral planar coil (SIM)

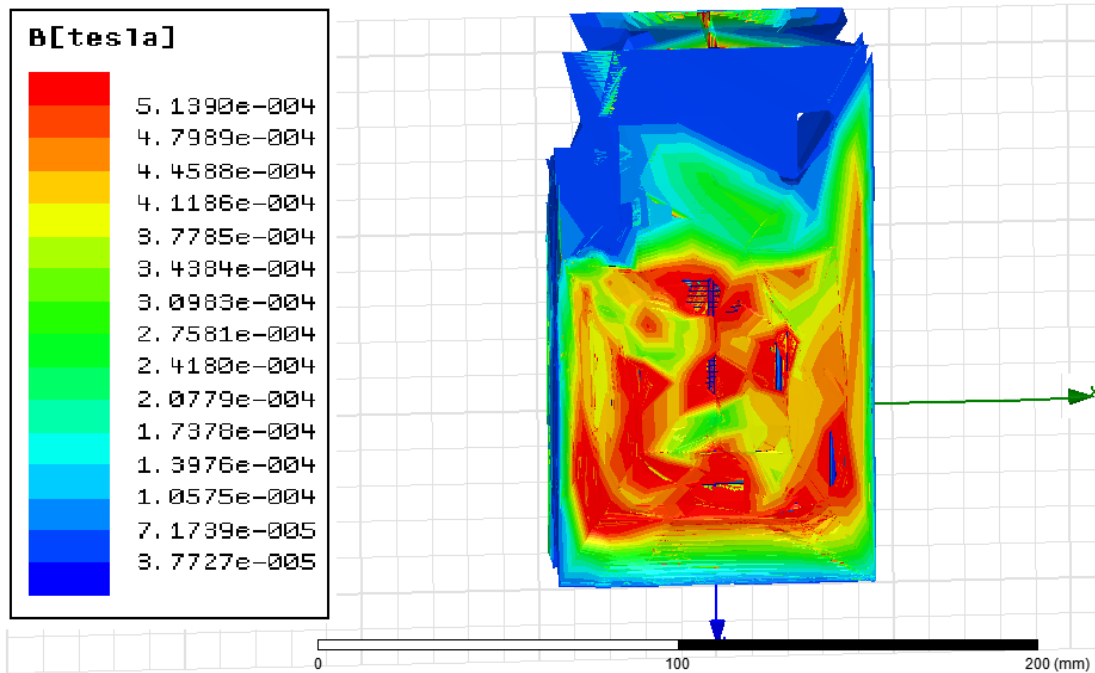
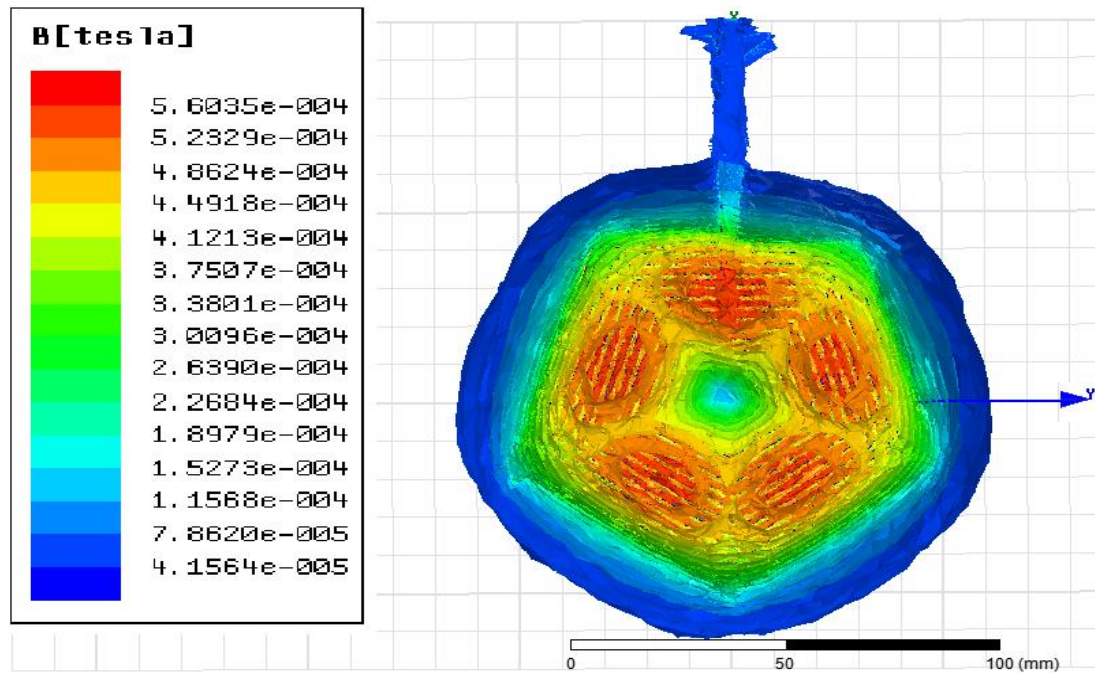


Figure 26: Magnetic flux of square planar coil (SIM)



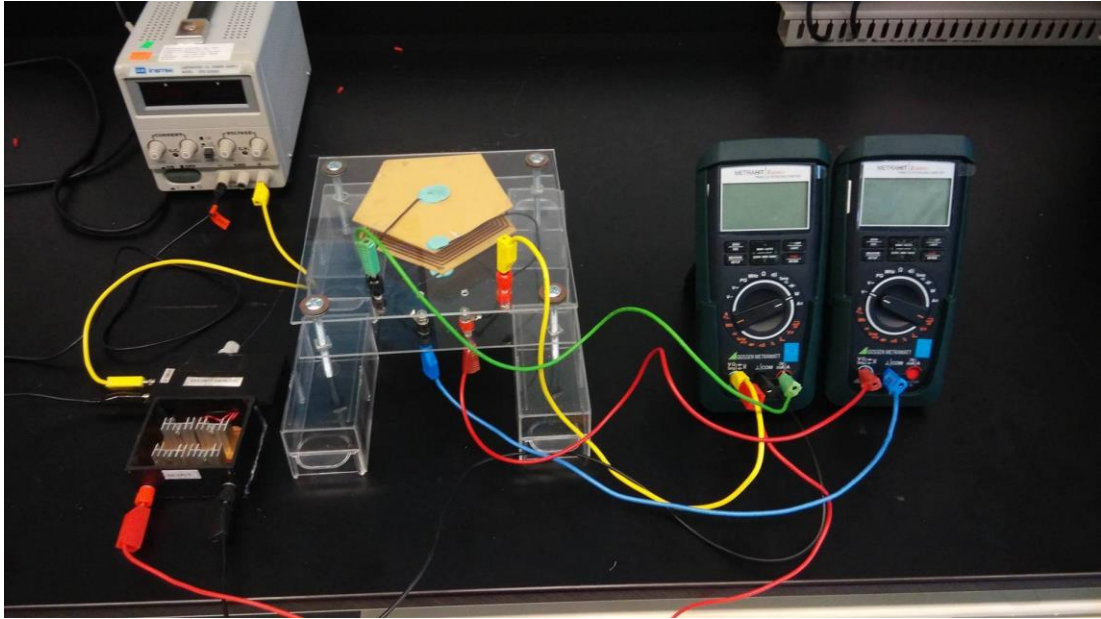


**Figure 27: Magnetic flux of pentagon planar coil (SIM)**

The plotted graphs above can be explained by **Figure 25**, **Figure 26**, and **Figure 27**. As author observe, different coil geometries can produce different types of magnetic field and flux. From the figure above, pentagon planar coil can generate the highest magnetic flux which is  $5.6035 \times 10^{-4}$  T. It is followed by square planar coil which has  $5.1930 \times 10^{-4}$  T of magnetic flux, then  $4.7120 \times 10^{-4}$  T for the spiral planar coil. To be related, the higher the magnetic flux, the higher the mutual inductance, and the higher the coupling coefficient.

### 4.3.2 Experimental Result

The experiment is designed with input voltage and current which are 12V and 1A respectively. Meanwhile, the switching frequency in the primary circuit is 500kHz is used to produce the AC into the primary coil. The following figure shows the setup of the experiment.



**Figure 28: The prototype experiment setup**

DC power supply will provide the DC voltage and current to the primary circuit which will convert the DC to AC by using switching devices. A carrying 500kHz AC will go into the primary coil and produce the magnetic flux. In the end, the power will be transfer to the secondary coil. Experiment is carried out by varying the distance of the air gap between primary coil and secondary coil to investigate the performance of each different shape of coil. In addition, the result will be taken directly from the primary coil and secondary coil purely without taking in account of the power loss at the DC to AC converter. Lastly, the result and data is observed and collected.

Experimental result had been collected and tabulated from the prototype testing. The output power is the core element that is needed in further calculation of mutual inductance and coupling coefficient according to Eq. (3) and Eq. (13). The experimental mutual inductance and coupling coefficient will be taken to compare with the simulation result in order to achieve the verification on the graph for each coil.



## Spiral Planar Coil

**TABLE XI: Input and output power for spiral planar coil**

Air Gap (cm)	Input Voltage (V)	Input Current (A)	Input Power (W)	Output Voltage (V)	Output Current (A)	Output Power (W)	Power Efficiency
1	1.14	0.88	1.0032	1.6	0.36	0.576	57%
2	1.14	0.88	1.0032	1.2	0.2	0.24	24%
3	1.14	0.88	1.0032	0.61	0.17	0.1037	10.30%
4	1.14	0.88	1.0032	0.64	0.025	0.016	1.60%

**TABLE XII: Mutual inductance and coupling coefficient for spiral planar coil**

Air Gap (cm)	Mutual Inductance (uH)	Coupling Coefficient
1	3.876182837	0.369428433
2	2.502065263	0.238465028
3	1.644683709	0.156750326
4	0.646030473	0.061571405

## Square Planar Coil

**TABLE XIII: Input and output power for square planar coil**

Air Gap (cm)	Input Voltage (V)	Input Current (A)	Input Power (W)	Output Voltage (V)	Output Current (A)	output power (W)	Power Efficiency
1	1.14	0.88	1.0032	1.72	0.33	0.568	57%
2	1.14	0.88	1.0032	1.17	0.27	0.316	31.40%
3	1.14	0.88	1.0032	0.95	0.12	0.114	11.40%
4	1.14	0.88	1.0032	0.77	0.028	0.0216	2.20%

**TABLE XIV: Mutual inductance and coupling coefficient for square planar coil**

Air Gap (cm)	Mutual Inductance (uH)	Coupling Coefficient
1	3.961853227	0.365182662
2	2.955069884	0.272382702
3	1.774911242	0.163601924
4	0.772593571	0.071213586

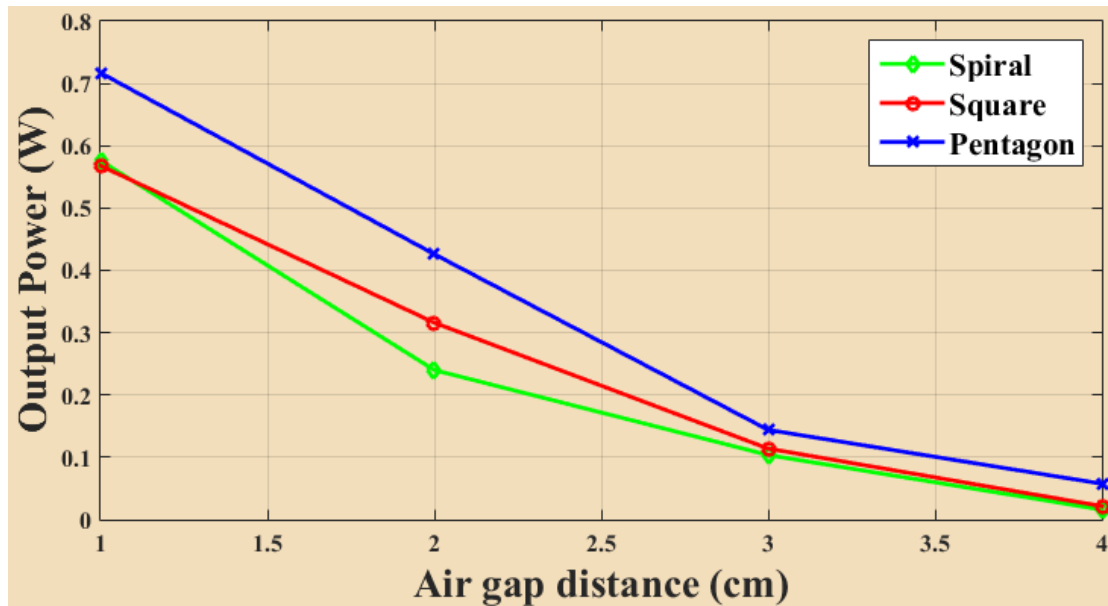
## Pentagon Planar Coil

**TABLE XV: Input and output power for pentagon planar coil**

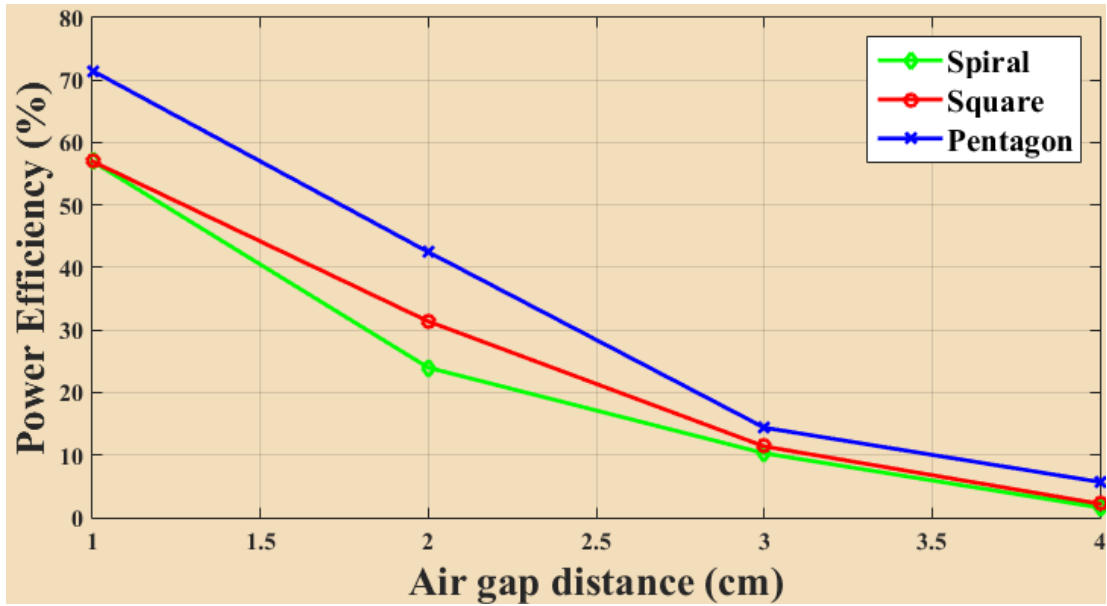
Air Gap (cm)	Input Voltage (V)	Input Current (A)	Input Power (W)	Output Voltage (V)	Output Current (A)	output power (W)	Power Efficiency
1	1.14	0.88	1.0032	1.63	0.44	0.717	71.50%
2	1.14	0.88	1.0032	1.29	0.33	0.426	42.50%
3	1.14	0.88	1.0032	0.76	0.19	0.144	14.40%
4	1.14	0.88	1.0032	0.48	0.12	0.0576	5.70%

**TABLE XVI: Mutual inductance and coupling coefficient for square planar coil**

Air Gap (cm)	Mutual Inductance (uH)	Coupling Coefficient
1	4.324666184	0.42818477
2	3.33347968	0.330047493
3	1.938091419	0.191890239
4	1.225756639	0.121362043

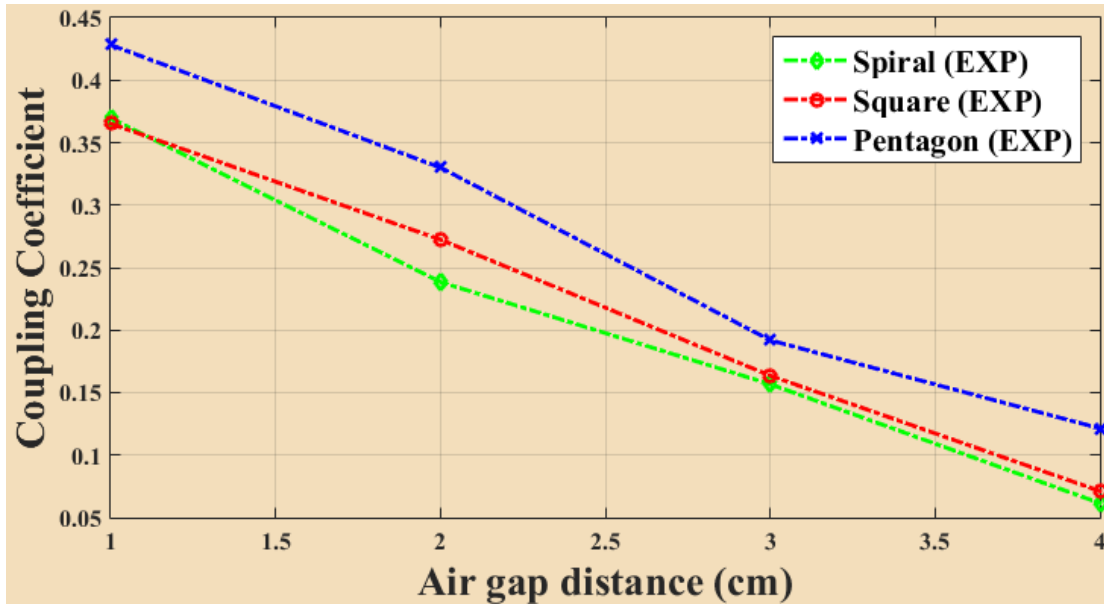


**Figure 29: Graph of output power against air gap distance (EXP)**

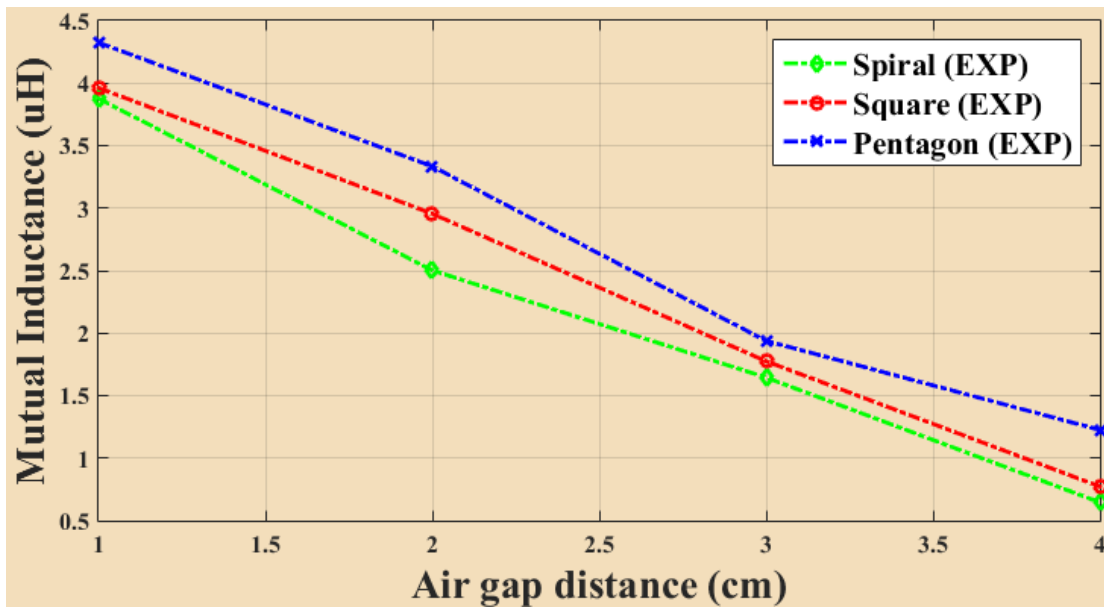


**Figure 30: Graph of power efficiency against air gap distance (EXP)**

According to **Figure 29** and **Figure 30**, there are the results from the experiment. Power efficiency drops when the air gap distance increases. Besides, author can say that pentagon planar coil has the best performances among all coils. It produces the highest power efficiency which is 71.5%, is much higher than the power efficiency produced by square and spiral planar coil. Meanwhile, square planar coil is the second place in term of power efficiency.



**Figure 31: Graph of coupling coefficient against air gap distance (EXP)**



**Figure 32: Graph of mutual inductance against air gap distance (EXP)**

According to the **Figure 31** and **Figure 32**, author is able to observe that the mutual inductance and coupling coefficient truly decreases as same as simulation result. As the distance of air gap increases, the mutual inductance and coupling coefficient drops. By comparing the three coils, pentagon planar is having the highest mutual inductance and coupling coefficient. Meanwhile, square planar comes to second and spiral planar is the last place.

### 4.3.3 Comparison between Experimental and Simulation result

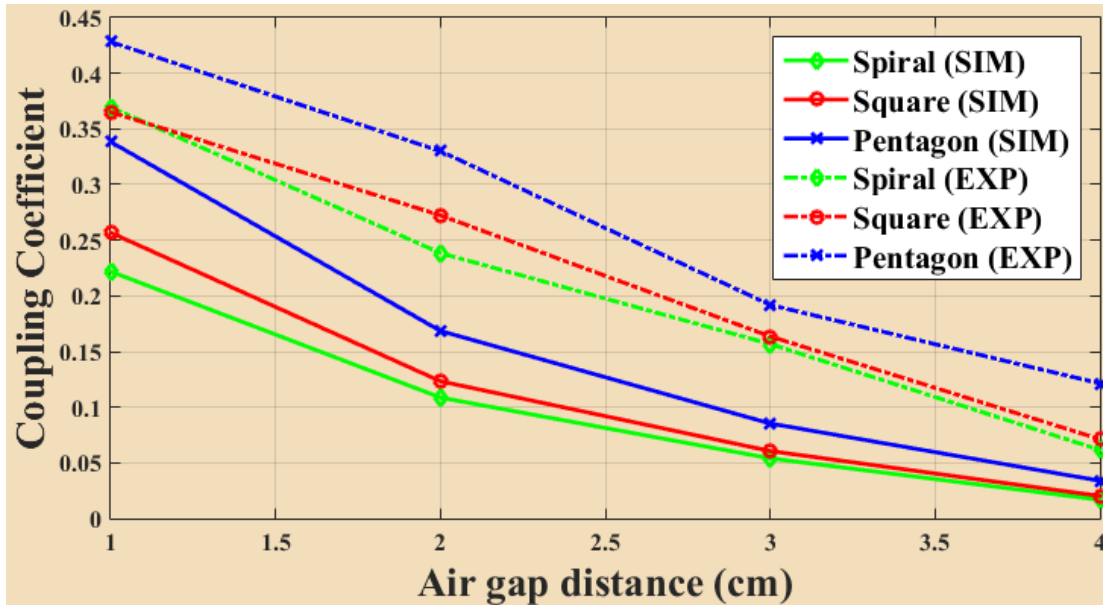


Figure 33: Graph of coupling coefficient against air gap (SIM Vs. EXP)

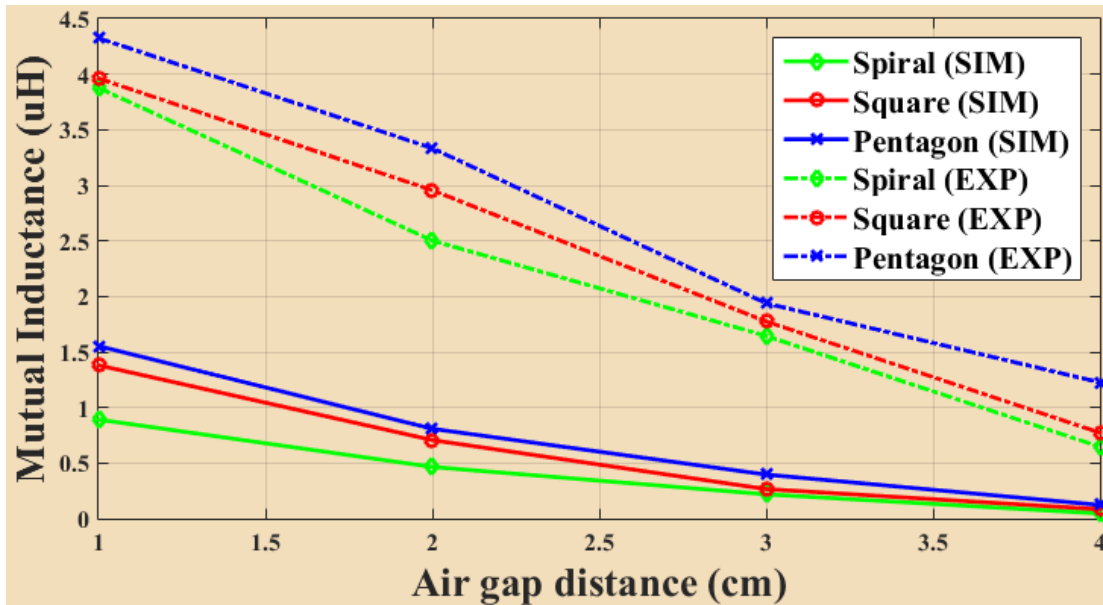


Figure 34: Graph of mutual inductance against air gap (SIM Vs. EXP)

By comparing the both experimental result and simulation result, they have a common point where the same pattern of performances exists. In a sense, the mutual inductance will decrease when the air gap increases, meanwhile same goes for the coupling coefficient no matter what shape of coil it is. To be more details, it is due to the leakage inductance increasing because of air gap increases. Meanwhile, both

results also show that the performance trend of pentagon planar coil is slightly higher than spiral planar coil and square planar coil while square planar coil is better than spiral planar according to **Figure 29**, **Figure 30**, **Figure 33** and **Figure 34**. The performance trends are:

Pentagon > Square > Spiral

These patterns are caused by the magnetic flux of each different geometries of coil in the simulation according to **Figure 25**, **Figure 26** and **Figure 27**, which means different geometries of coil can produce different magnetic flux. From the figure above, pentagon planar coil can generate the highest magnetic flux which is  $5.6035 \times 10^{-4}$  T. It is followed by square planar coil which has  $5.1930 \times 10^{-4}$  T of magnetic flux, then  $4.7120 \times 10^{-4}$  T for the spiral planar coil. The higher the magnetic flux, the higher the mutual inductance, and the higher the coupling coefficient. In addition, this will even lead to higher power efficiency where is proven by **Figure 29** and **Figure 30**. From there, they also follow the same performances trend as mentioned above.

## **CHAPTER 5**

### **CONCLUSION AND RECOMMENDATION**

#### **5.1 CONCLUSION**

A comparative study of various shapes of coils for WPT had been investigated and verified through experiment and simulation. Three geometries of coils in simulation was designed and simulated by finite element method Ansoft Maxwell to calculate the mutual inductance and coupling efficient over varying the distance of air gap (z-direction). In order to verify and validate the results, experimental setup had been built. Different geometries of coil will produce different magnetic flux. And also, this will contribute to the mutual inductance and coupling efficient. The higher the magnetic flux, the higher the mutual inductance, and the higher the coupling coefficient where will increase power efficiency also. However, mutual inductance and coupling will decrease when the air gap distance increases. In terms of performance, pentagon is the best coil among all geometries of coil. Last but not least, both experimental and simulation results are reported to have the same performance trends such as pentagon > square > spiral.

#### **5.2 RECOMMENDATION**

Throughout the experiment and simulation, author is able to understand what the next jobscope will be and there are more to come. Author found out that the simulation and analysis in Ansoft Maxwell will take longer time to finish, and even it will be terminated and killed automatically due to the low memory (ROM) of laptop. As for the recommendation, it is better to work on the Ansoft Maxwell with a high-spec desktop and a server, so that the simulation will be run and finished in a shorter time. Other than that, Ansoft Maxwell is recommended to work with other software such as Ansoft Simplorer established by same company. It is because the Ansoft Simplorer is a circuit simulator which can design the circuit including S-S compensation circuit, switching circuit and others which will work together with the coil design model in Ansoft Maxwell.

For the experiment, the switching device in the primary circuit is getting hotter in high frequency input when testing takes longer time. It could be the power loss in the switching circuit that will affect the total output power. Therefore, it is better to have a larger and cooler heatsink, meanwhile it is advisable to have a cooling pad to cool down the heat in switching device so that a better and accurate result could be obtained. In a result, the data and information such as total power transfer, voltage, current at the load will be calculated and obtained. From that, the objective and significance of this paper will be achieved.

In addition, PCB coil is still using copper sheet for the winding and it could not provide high power efficiency due to the skin effect and proximity effect. In order to reduce these effects, it is recommended to use Litz wire which has two or more twisted copper wire to enhance the power efficiency. Other than that, adding a ferrite core at the windings could be a good choice to re-shape the magnetic field for reducing the leakage inductance which can increase the mutual inductance.



## REFERENCES

- [1] J. L. Villa, J. Sallán, A. Llombart, and J. F. Sanz, "Design of a high frequency Inductively Coupled Power Transfer system for electric vehicle battery charge," *Appl. Energy*, vol. 86, no. 3, pp. 355–363, 2009.
- [2] K. Y. Yee, "Development of Wireless Charging for Mobile Application using PV Module," *Igarss 2014*, no. 1, pp. 1–5, 2014.
- [3] a. P. Hu and C. Liu, "Steady state analysis of a capacitively coupled contactless power transfer system," *2009 IEEE Energy Convers. Congr. Expo.*, pp. 3233–3238, 2009.
- [4] K. Aditya and S. S. Williamson, "Design considerations for loosely coupled inductive power transfer (IPT) system for electric vehicle battery charging - A comprehensive review," *Transp. Electrification Conf. Expo (ITEC), 2014 IEEE*, pp. 1–6, 2014.
- [5] A. Dalal, T. P. E. R. Joy, and P. Kumar, "Mutual Inductance Computation Method for Coils of Different Geometries and Misalignments," 2015.
- [6] C. L. W. Sonntag, E. A. Lomonova, and J. L. Duarte, "Implementation of the Neumann Formula for Calculating the Mutual Inductance between Planar PCB Inductors," pp. 1–6, 2008.
- [7] C.-S. Wang, O. H. Stielau, and G. a. Covic, "Design Considerations for a Contactless Electric Vehicle Battery Charger," *IEEE Trans. Ind. Electron.*, vol. 52, no. 5, pp. 1308–1314, 2005.
- [8] A. Wahab, T. E. Chong, and L. K. Min, "Wireless pointing device using capacitive coupling," no. 639798, pp. 149–152, 1997.
- [9] B. Choi, J. Nho, H. Cha, T. Ahn, and B. Choi, "Design and implementation of low-profile contactless battery charger using planar printed circuit board windings as energy transfer device," *Ind. Electron. IEEE Trans.*, vol. 51, no. 1, pp. 140–147, 2004.
- [10] T. C. Y. Ho, B. Gomersall, and L. Ran, "Contactless charging for electric vehicles with a large air gap," *Proc. 2011 14th Eur. Conf. Power Electron. Appl.*, vol. 44, no. 0, pp. 1–10, 2011.
- [11] C. Zheng, J.-S. Lai, R. Chen, W. E. Faraci, Z. U. Zahid, B. Gu, L. Zhang, G. Lisi, and D. Anderson, "High Efficiency Contactless Power Transfer System for Electric Vehicle Battery Charging Application," *IEEE J. Emerg. Sel. Top. Power Electron.*, vol. 6777, no. c, pp. 1–1, 2014.
- [12] C. Fernandez, O. Garcia, R. Prieto, J. a. Cobos, S. Gabriels, and G. Van Der Borgh, "Design issues of a core-less transformer for a contactless application," *APEC. Seventeenth Annu. IEEE Appl. Power Electron. Conf. Expo. (Cat. No.02CH37335)*, vol. 1, no. 1, pp. 339–345, 2002.

- [13] M. Ryu, J. Kim, J. Baek, and H. Cha, "Analysis of the Contactless Power Transfer System Using Modeling and Analysis of the Contactless Transformer," vol. 1, no. 3, pp. 351–358, 2006.
- [14] S. L. Ho, J. Wang, W. N. Fu, and M. Sun, "A comparative study between novel witrlicity and traditional inductive magnetic coupling in wireless charging," *IEEE Trans. Magn.*, vol. 47, no. 5, pp. 1522–1525, 2011.
- [15] Z. N. Low, R. A. Chinga, R. Tseng, and J. Lin, "Design and test of a high-power high-efficiency loosely coupled planar wireless power transfer system," *IEEE Trans. Ind. Electron.*, vol. 56, no. 5, pp. 1801–1812, 2009.
- [16] J. Sallan, J. L. Villa, a. Llombart, and J. F. Sanz, "Optimal Design of ICPT Systems Applied to Electric Vehicle Battery Charge," *IEEE Trans. Ind. Electron.*, vol. 56, no. 6, pp. 2140–2149, 2009.
- [17] M. Z. Zainol, N. A. B. D. Rahim, and J. Selvaraj, "Design and analysis of contactless transformer using series resonant converter," no. 5, pp. 192–195, 2013.
- [18] L. H. Tan, "IMPROVING EFFICIENCY OF WIRELESS POWER TRANSFER by CERTIFICATION OF APPROVAL IMPROVING EFFICIENCY OF WIRELESS POWER TRANSFER," no. January, 2014.
- [19] Y. Nagatsuka, N. Ehara, Y. Kaneko, S. Abe, and T. Yasuda, "Compact contactless power transfer system for electric vehicles," *2010 Int. Power Electron. Conf. - ECCE Asia -, IPEC 2010*, pp. 807–813, 2010.
- [20] J. J. Casanova, Z. Ning Low, J. Lin, and R. Tseng, "Transmitting coil achieving uniform magnetic field distribution for planar wireless power transfer system," *RWS 2009 IEEE Radio Wirel. Symp. Proc.*, pp. 530–533, 2009.
- [21] J. J. Casanova, Z. N. Low, and J. Lin, "A loosely coupled planar wireless power system for multiple receivers," *IEEE Trans. Ind. Electron.*, vol. 56, no. 8, pp. 3060–3068, 2009.
- [22] O. H. Stielau and G. a Covic, "Design of loosely coupled inductive power transfer systems," *Power Syst. Technol. 2000. Proceedings. PowerCon 2000. Int. Conf.*, vol. 1, pp. 85–90 vol.1, 2000.