

## **ABSTRACT**

Friction Stir Welding (FSW) is a method to join solid-state metal plates. This technique was started in 1991 and since then, many studies and research have been done in order to improve this method. People are really interested in this technique because they realized this technique has more advantages and have many potential for improvement. In this project, the effect of different tool pin geometry on the welding plate's microstructure will be investigated. Three different geometry tools pin, round, square, and triangular will be used to fabricate the joints. After that, the formations of friction stir plate's microstructural zone will be analyzed. There are several parameters that will effects the formation of the microstrutural zone. In this project, since our main purpose is to study the effect of tool pin profiles on the microstructure of friction stir welding plates, others parameter such as tool rotational speed, and welding speed, and axial force are constant. It is found that rectangular tools (Sample 5) have the best microstructure quality out of all three tools. Sample 5 shown smallest grain size. Smaller grain size is preferable because it result in more grain boundaries that strengthen the material. Grain boundaries increase the strength of aluminum by resisting the movement of dislocations in the microstructure. Therefore, more force is required to deform a material when it has large quantity of grain boundaries. In FSW, a good weld quality could be defined base on the strength of the joint. To fulfill the desired strength, proper welding parameters should be selected.

## Table of Contents

ABSTRACT.....	1
<b>List of Figures</b> .....	4
CHAPTER 1: INTRODUCTION .....	6
1.1: Background of Study .....	6
1.2 Problem Statement .....	6
1.3 Problem Identification.....	6
1.4 Significance of Project .....	7
1.5 Objective .....	7
CHAPTER 2: LITERATURE REVIEW AND THEORY .....	8
2.1 Tools.....	10
2.2 Comparison of Material Flow between Straight and Tapered Cylindrical Tool Pins. ....	11
2.3 Influences of Tool Pin Profile and Tool Shoulder Diameter on the Formation of Friction Stir Welding Zone .....	12
2.4 Influences of Tool Pin Profile and Axial Force on the Formation of Friction Stir Welding Zone .....	13
2.5 Influence of Tool Geometry on the Thermo-mechanical And Microstructural Behavior in Friction Stir Welding Plates .....	14
2.6 Statistical Analysis on Mechanical Properties of Friction-Stir-Welded .....	15
CHAPTER 3: RESEARH METHODOLOGY .....	16
3.1 Project Methodology.....	16
3.2 Heat Treatment of FSW Tool.....	19
3.3 Procedure of FSW Process.....	20
3.4 Specimen Preparation for Microstructure Testing .....	23
3.4.1 Cutting.....	23
3.4.2 Grinding .....	24
3.4.3 Polishing.....	25
3.4.4 Etching .....	26
3.5 Microstructure Examination.....	28
3.6 Gantt Chart / Key Milestone .....	31
3.6.1 FYP I.....	31
3.6.2 FYP II.....	31

CHAPTER 4: RESULT & DISCUSSION.....	32
4.1 Heat Treatment of FSW Tool.....	32
4.2 Friction Stir Welding Process .....	33
4.3 Internal Defects .....	37
4.4 Microstructural Region Analysis .....	39
4.5 Microstructure Analysis .....	40
CHAPTER 5: CONCLUSIONS AND RECOMMENDATIONS .....	46
5.1 Limitation in this project.....	46
5.2 Recommendation .....	47

## List of Figures

Figure 1: Microstructural regions of a friction stir welded material [2] .....	10
Figure 2: FSW pin profiles: (a) Straight cylindrical pin, (b) Tapered cylindrical pin. The dimensions are in mm [3].....	11
Figure 3: FSW tool pin profiles [4].....	12
Figure 4: View of tools specifications used in this work [6] .....	14
Figure 5: Flow chart of project.....	16
Figure 6: Dimensions of FSW tools.....	17
Figure 7: Different geometry of tool pin.....	17
Figure 8: FSW tools after CNC processing.....	18
Figure 9: Top view of jig.....	18
Figure 10: Side view of jig.....	19
Figure 11: H13 Tool Steel Heat Treatment Process.....	20
Figure 12: Bridgeport milling machine at Block N.....	20
Figure 13: Aluminum plates will butt closely on jig and tightened with bolts and nuts. 21	
Figure 14: H13 tool steel is ready for FSW .....	21
Figure 15: Workpiece undergo FSW process .....	22
Figure 16: Abrasive cutter.....	23
Figure 17: Portion of FSW plates cut.....	24
Figure 18: Grinder & polisher .....	24
Figure 19: Tri-cloth, Metadi fluid & diamond paste.....	26
Figure 20: Apparatus for etching process .....	27
Figure 21: Optical Microscope.....	28
Figure 22: FSW tools before heat treatment .....	32
Figure 23: FSW tools after heat treatment .....	32
Figure 24: Sample 1, FSW plates (Round tool, 50 mm/min).....	34
Figure 25: Sample 2, FSW plates (Round tool, 75 mm/min).....	34
Figure 26: Sample 3, FSW plates (Round tool, 100 mm/min).....	35
Figure 27: Sample 4, plates (Triangular tool, 50 mm/min).....	35
Figure 28: Sample 5, FSW plates (Rectangular tool, 50 mm/min).....	36
Figure 29: Expected Microstructural Region [10] .....	39
Figure 30: Biggest spot on sample that optical microscope can capture .....	39
Figure 31: HAZ on Sample 5 Microstructural Region.....	39
Figure 32: Region on samples where microstructure image captured using Optical Microscope .....	40

**List of Tables**

Table 1: Composition of AISI H13 ..... 11

Table 2: Parameter for FSW process..... 22

Table 3: Grinding process parameter ..... 25

Table 4: List of tool/equipment required..... 29

Table 5: Gantt chart /Key Milestone for FYP I..... 31

Table 6: Gantt chart /Key Milestone for FYP II ..... 31

Table 7: Parameter for FSW process..... 33

Table 8: Internal defects of FSW plates ..... 37

Table 9: 50x magnifications for round tool with different translational speed ..... 41

Table 10: 100x magnifications for round tool with different translational speed ..... 42

Table 11: 50x magnifications for different tools pin shape with same translational speed  
..... 43

Table 12: 100x magnifications for different tools pin shape with same translational  
speed..... 44

## **CHAPTER 1: INTRODUCTION**

### **1.1: Background of Study**

Friction Stir Welding (FSW) is a solid-state joining technique and was initially applied to aluminum alloys. It was invented at The Welding Institute (TWI) of the United Kingdom in 1991 by Wayne Thomas and his team [1]. It is widely used in marine automotive, aerospace, railway and many other applications. The process is using a non-consumable rotating tool that is inserted into the abutting edges of two plates to be joined and after that traversed along the joint line. For the past few years, many researches had been done in order to improve this process. It has been proved that this process is more advantageous as compared to the conventional arc welding methods, such as higher mechanical properties, lower residual stress and reduced occurrence of welding defects.

According to some published works, there are a few researches considering the effect of the tool profile in this operation [1]. However, more studies need to be done in order to understand more about the effect of tool geometry on microstructure of the friction stir welding plates.

### **1.2 Problem Statement**

To study the effect of different geometry of pin profile on the microstructure of friction stir welding plates.

### **1.3 Problem Identification**

There are several welding parameters that will influence the performance of the FSW joint. Among all the parameters, tool pin profile plays an important role in determining the weld quality. In friction stirring, three common imperfections are voids, joint line remnants, and incomplete root penetration. In order to design FSW tool, all of these factors need to be considered. In this project, the author will find the relation of the tool pin profile geometry with the imperfections of friction stirring by studying the microstructure of the friction stir welding plates.

## **1.4 Significance of Project**

Friction stir welding is a relatively new process invented. From time to time more study and researches have been done to understand and improve this process. Geometric parameter of the tool pin plays very important roles because it influences both metal flow and heat generation. This factor also influences the formation of defects during welding operations. By studying the effect of different geometry of tool pin profile on the microstructure, better tool can be designed and the process can be improved.

## **1.5 Objective**

The objective of this project is to investigate the effect of different geometry of tool pin profile on the microstructure of friction stir welding plates. Tool with round, square and triangular pin profile will be designed and used in the FSW process and microstructure of the sample will be investigated.

## **1.6 Scope of Study**

In this project, three different geometry of tool pin will be used. There are round, square, and triangular shapes of tool pin. Parameters that influence the performance of friction stir welding are:-

- i. Tool rotational speed
- ii. Welding speed
- iii. Axial force
- iv. Tool pin profile

In this project, our main purpose is to study the effect of tool pin profile on the microstructure of friction stir welding plates, thus in this study only tool pin geometry parameter will vary. Apart from that, other parameters will be constant throughout the experiments.

## CHAPTER 2: LITERATURE REVIEW AND THEORY

Friction stir welding (FSW) process uses a non-consumable rotating tool inserted into the abutting edges of two plates to be joined. The tool then will traverse along the joint line. Parameters that influence the performance of friction stir welding are:-

- i. Tool rotational speed
- ii. Welding speed
- iii. Axial force
- iv. Tool pin profile

This project will focus more on the effects of the tool pin profile geometry on the microstructure of the friction stir plates. In FSW process, rotating tool plays very important roles because it influences both metal flow and heat generation. This factor also influences the formation of defects during welding operations. The tool has three primary functions, which are:-

- i. Heating of the workpiece
- ii. Movement of material to produce the joint
- iii. Containment of the hot metal beneath the tool shoulder.

In FSW process, the friction between the rotating tool pin and shoulder will create heating. The mechanism of the localized heating will soften the material around the pin. The effect of this phenomenon, combined with the tool rotation and translation, will lead to the movement of material from the front to the back of the pin, and filling the hole in the tool wake as the tool moves forward. During the process, the tool shoulder restricts metal flow to the initial workpiece top surface, which is equivalent with the shoulder position. The no-melting solid-state joint phenomenon is created as the result of the tool action and influence on the workpiece.

Various geometrical features on the tool will cause the material movement around the pin to be complex, with gradients in strain, temperature, and strain rate. Due to this, the resulting nugget zone microstructure is not homogenous. Although it is not homogenous, features of this process that are very significant is the solid-state welding



technique is fully recrystallized, equiaxed, fine grain microstructure created in the nugget by the intense plastic deformation at elevated temperature. The resulted of the fine grain microstructure will produce excellent mechanical properties, fatigue properties, enhanced formability, and exceptional super plasticity [2].

After FSW process, different microstructural zone exists. The microstructural zone can be broken up into the following region as shown in Figure 1:-

- A. Unaffected material or parent metal: - this is the most outer region of the microstructure part. This region may have experienced a thermal cycle from the weld but it is not affected by the heat in terms of microstructure or mechanical properties, so it has not been deformed.
- B. Heat-affected zone: - this region is closer to the weld-center. Material in this region experienced a thermal cycle that has modified the microstructure and mechanical properties. Although it experienced thermal cycle, there is no plastic deformation occurring in this region.
- C. Thermomechanically affected zone (TMAZ): - this region is the nearest to the weld nugget region. In this region, heat from FSW region has exert some influence on the material and FSW tool will plastically deformed the material. If aluminum plates are used for FSW process, it is possible to obtain significant plastic strain without recrystallization in this region, and there is generally a distinct boundary between the recrystallized zone (weld nugget) and the deformed zones of the TMAZ.
- D. Weld nugget/stir zone: - this is a fully recrystallized area. Material in this region deformed heavily due to the location of the pin during welding.

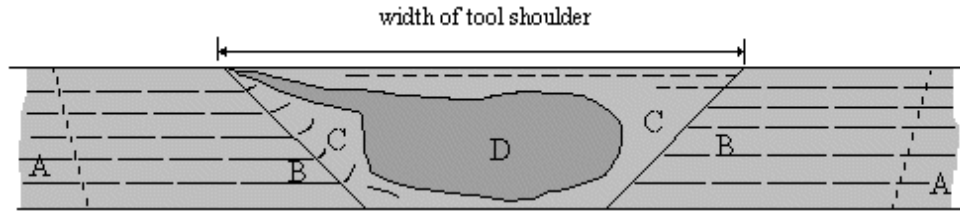

*Figure 1: Microstructural regions of a friction stir welded material [2]*

The quality of FSW process will depend on the type of microstructure that exists after the process. Based on the available literature, it is proven that geometric parameter of the tool pin play very important roles because it influences both metal flow and heat generation, due to frictional stress and also the formation of defects during welding operations. According to published work, a few researches have been done related with the effect of tool profile in FSW operation [4] [5]. However, more studies need to be done in order to understand this technology deeper. In this project, effect of different geometry of tool pin profile on the microstructure of friction stir welding plates will be studied.

## **2.1 Tools**

Tool shoulders are designed to produce heat to the surface and the subsurface regions of the workpiece. The pins in other hand will produce deformational and frictional heating to the joint surface. The most common material used for aluminum alloys plates FSW process tool is steel. For this project, AISI H13 will be used for the tool. H13 is a type of hot-worked tool steel. Chemical composition of H13 is shown in Table 1. The advantages of using tool steel are;

- i. Easy availability and machinability
- ii. Low cost
- iii. Strength at elevated temperatures
- iv. Hardness at elevated temperatures
- v. Thermal fatigue resistance
- vi. Wear resistance

Table 1: Composition of AISI H13

AISI No	C %	Mn %	W %	Si %	Cr %	Mo %	V %	Co %
H13	0.35	0.40	-	1.0	5.0	1.5	1.0	-

## 2.2 Comparison of Material Flow between Straight and Tapered Cylindrical Tool Pins.

The welds were performed using two different tools pin profile: the first tool has a straight cylindrical pin whereas the second tool has a tapered cylindrical pin with three flats. The impact of the shoulder results from two effects: a thermal effect relating to the frictional heating and a mechanical effect related to the capacity of the shoulder to drive the flow. The mechanical effect is related to the material behavior but also to the contact area between the shoulder and the plate [3].

Tool pin profiles used with straight cylindrical pin and tapered cylindrical pin is shown in Figure 2 below:-

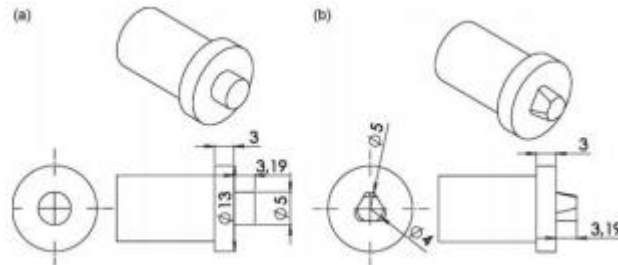

Figure 2: FSW pin profiles: (a) Straight cylindrical pin, (b) Tapered cylindrical pin. The dimensions are in mm [3]

The material flow during the FSW of thin plates was analyzed when using unthreaded pins. Both pins have or do not have flat faces. Material flow with unthreaded was found to have the same features as material flow using classical threaded pins. The shoulder and in particular the frictional heating play a key role on the material stirring.

The presence of flat faces on a pin creates a pulsating action which changes the flow generated by the shoulder and consequently reduces the role of the shoulder [3].

Thickness of the shoulder dominated zone is affected by plunge force and rotational speed of the tool. This effect can be reduced using cylindrical tapered pin with flats [3].

### 2.3 Influences of Tool Pin Profile and Tool Shoulder Diameter on the Formation of Friction Stir Welding Zone

Study was done by comparing between five different tool pin profiles: straight cylindrical (SC), taper cylindrical (TC), threaded cylindrical (TH), square (SQ), and triangular (TR). Tool pin profiles used in this study is shown in Figure 3. For every tool pin profiles, there are three shoulder diameter: 15mm, 18mm, and 21mm.

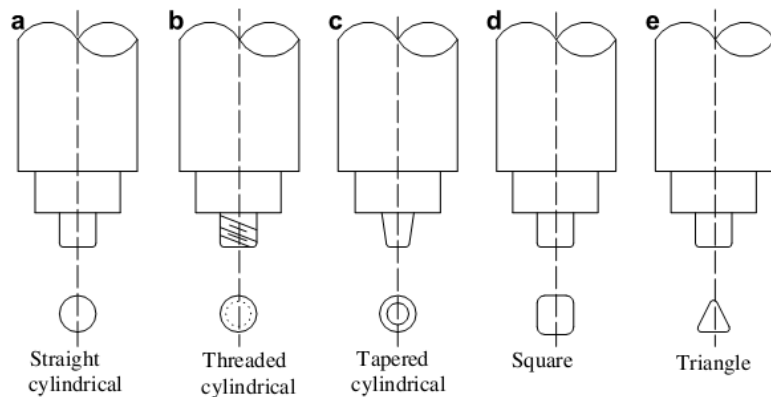

Figure 3: FSW tool pin profiles [4]

In this study an attempt has been made to study the effect of tool pin profile and tool shoulder diameter on the formation of friction stir processing zone in AA6061 aluminum alloy. From this investigation, the following important conclusions are derived:

- i. Of the five tools pin profiles used in this investigation to fabricate the joints, square pin profiled tool produced defect free FSW region, irrespective of shoulder diameter of the tools [4].

- ii. Of the three tool shoulder diameters used in this investigation to fabricate the joints, a tool with 18 mm shoulder diameter produced defect free FSW region, irrespective of tool pin profiles [4].
- iii. Of the 15 joints fabricated in this investigation, the joint fabricated using square pin profiled tool with shoulder diameter of 18 mm showed superior tensile properties [4].

#### **2.4 Influences of Tool Pin Profile and Axial Force on the Formation of Friction Stir Welding Zone**

Study was done by comparing between five different tool pin profiles: straight cylindrical (SC), taper cylindrical (TC), threaded cylindrical (TH), square (SQ), and triangular (TR). Tool pin profiles used in this study is shown in Figure 3. For every tool pin profiles, there different axial forces were applied: 6kN, 7kN, and 8kN.

Experiments were done to study the effect of tool pin profile and axial force on the formation of friction stir processing zone in AA6061 aluminum alloy. From the study, the following important conclusions are derived:

- i. Of the five tool pin profiles used in this investigation to fabricate the joints, square pin profiled tools produce defect-free, good quality FSW region, irrespective of applied axial force levels [5].
- ii. Of the three axial force levels used in this investigation to fabricate the joints, an axial force of 7 kN produces a defect-free FSW region, irrespective of tool pin profiles [5].
- iii. Of the 15 joints fabricated in this investigation, the joint fabricated using the square pin profiled tool at an axial force of 7 kN showed superior tensile properties. A defect-free FSW region, smaller grains with uniformly distributed finer strengthening precipitates in FSW region and higher hardness are the reasons for superior tensile properties of the joints [5].

## 2.5 Influence of Tool Geometry on the Thermo-mechanical And Microstructural Behavior in Friction Stir Welding Plates

The objective of this work is to study effect of tool geometric parameters on thermo-mechanical behavior in FSW plates. In this study, two approaches were used: using finite-element model and welding experiments. Specifications of welding tools used are shown in Figure 4.

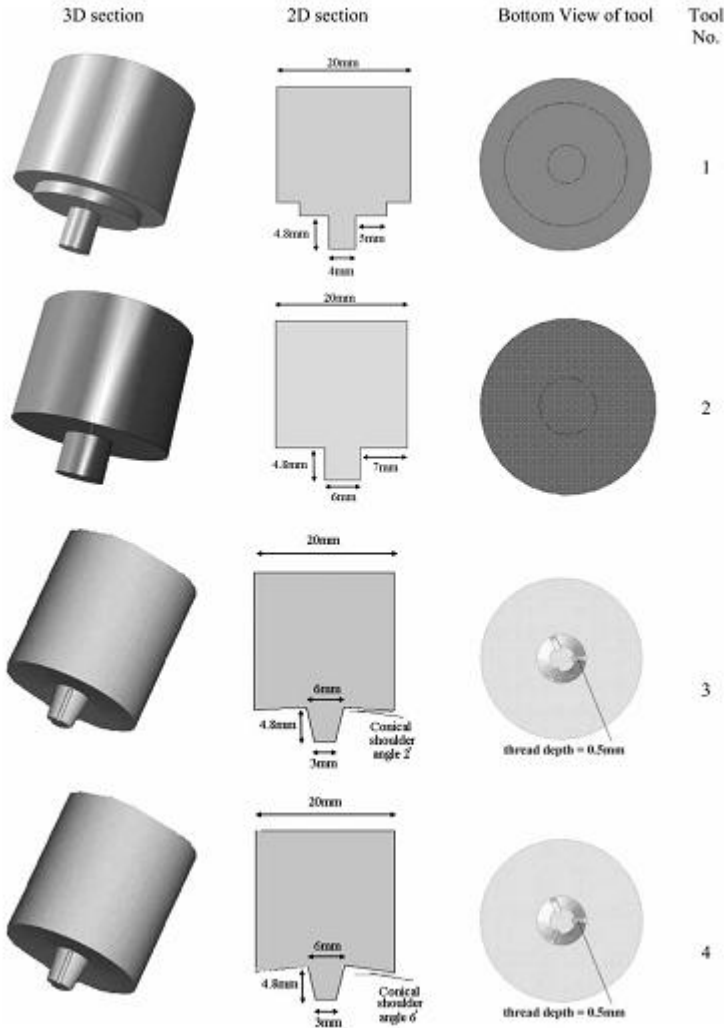

Figure 4: View of tools specifications used in this work [6]

Results from the study are concluded below:

- i. The higher mechanical properties have been achieved by the tool (3). The yield strength of weld was about 12 per cent greater than that of the base metal. On the other hand, welding by the tool (4) produces wormhole defects leading to poor mechanical properties [6].
- ii. According to simulation results, the heat generation from plastic and friction dissipation in the conical threaded pin were 44 per cent and 6 per cent more than the cylindrical pin with similar shoulder diameter, respectively [6].
- iii. The conical threaded pin exerts more upsetting effect on the workpiece and therefore, it produces larger plastic strain and wider deformation zone [6].

## **2.6 Statistical Analysis on Mechanical Properties of Friction-Stir-Welded**

The objective of this study is to investigate the effect of friction-stir welding (FSW) parameters experimentally. In this study, analysis of variance (ANOVA) and main effect plot were used to determine the significant parameters. Results of this study in concluded below:

- i. The ultimate tensile strength and nugget hardness increase with traverse speed [7].
- ii. The ultimate tensile strength and nugget hardness increase with tool rotational speed [7].
- iii. Based on ANOVA results, the most important factor on UTS by ranking is: - traverse speed, rotational speed and stirrer geometry [7].
- iv. Based on ANOVA results, the most important factor on nugget hardness by ranking is: - traverse speed, rotational speed and stirrer geometry [7].

## CHAPTER 3: RESEARCH METHODOLOGY

### 3.1 Project Methodology

This research is to study the microstructure formed at the FSW region. The problem statement and objective need to be determined clearly before proceeding to the next step. Flow chart of this project is shown in Figure 5.

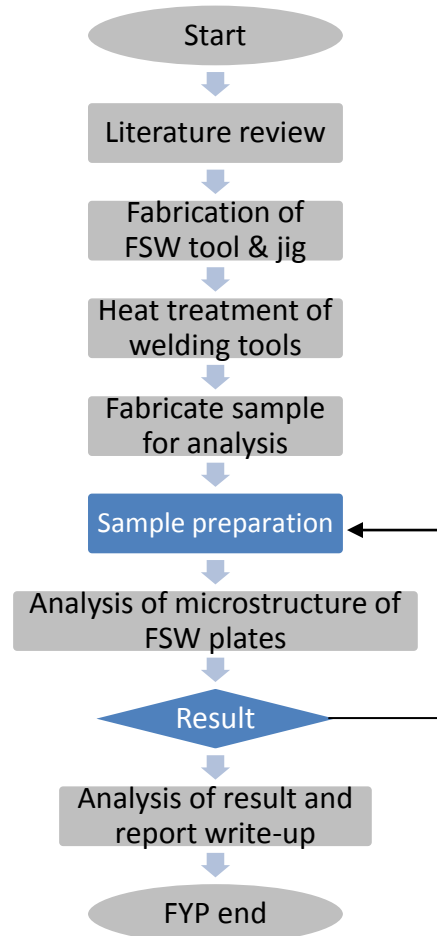

*Figure 5: Flow chart of project*

In order to start a project, as much possible information about the project need to be known. This is done by doing some research about the topic and writing a literature review about the topic. Other than related journals, study of heat generation during the process is necessary in order to correlate the processing parameters with the microstructure development.



### 3.1.1 Tool & Jig Fabrication

After the proposal is approved, fabrication of FSW tools and jig was started. Tool for FSW was fabricated using CNC Lathe machine. Dimensions of the tools are shown in Figure 6 as below:-

Part Name	Dimensions (mm)
Shaft	75
Diameter	20
Tip Diameter	10
Tip Length	8

*Figure 6: Dimensions of FSW tools*

Then, the welding tool needs to be heat treated for surface hardening. The purpose of heat treatment is to have a sufficiently strong, tough and hard wearing at the welding temperature tool material. The different in FSW tools pin geometry is shown in Figure 7 and Figure 8 shows FSW tools after CNC processing.

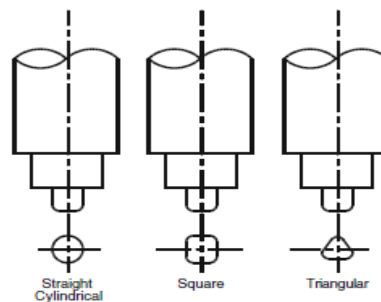
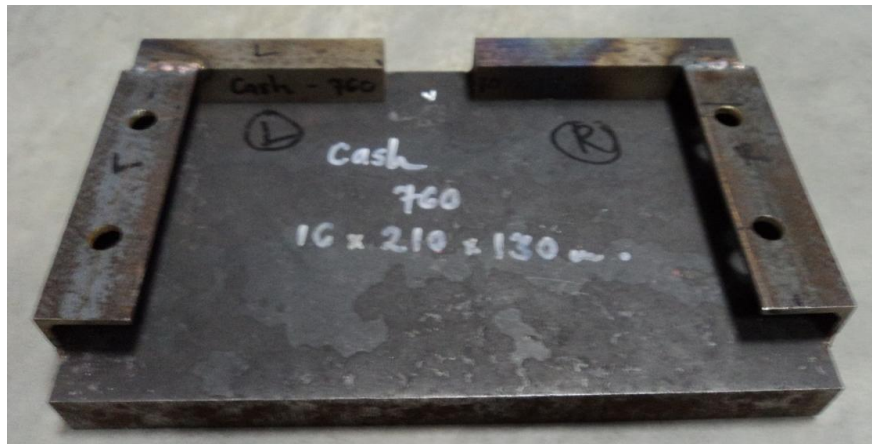

*Figure 7: Different geometry of tool pin*



*Figure 8: FSW tools after CNC processing*

For jig fabrication, the design was made based on size of aluminum that will be used for FSW process. After preparation of the material, fabrication of the jig was started. Picture of top and side view of the jig are shown in Figure 9 and Figure 10 respectively.



*Figure 9: Top view of jig*

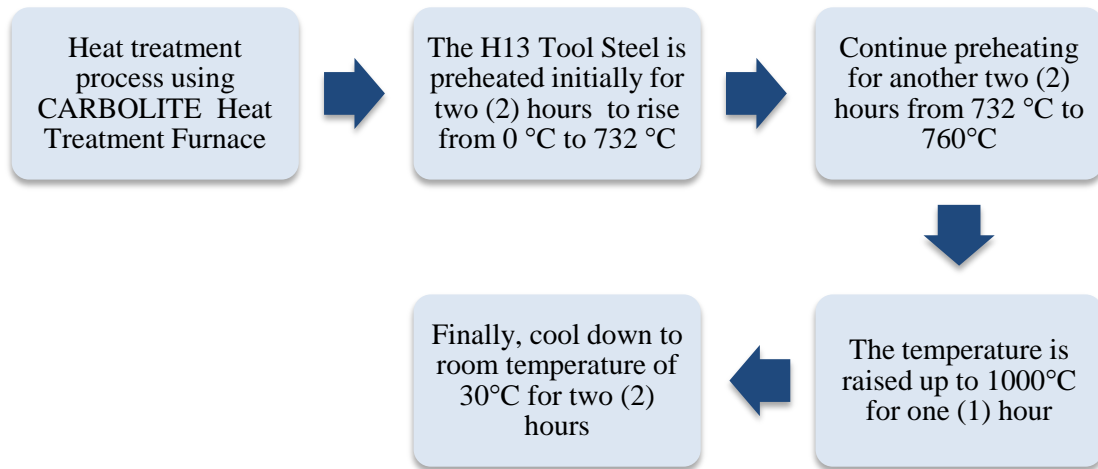

*Figure 10: Side view of jig*

After the tool fabrication process is completed, friction stir welding process can be run on the aluminum plates using different geometry welding tools. After that, sample preparation can be carried out to analyze the microstructure of the FSW plates using microscopic examination.

### **3.2 Heat Treatment of FSW Tool**

After the tools machining is finished, the tools need to be heat treated in order to harden it. The heat treatment process will be done using CARBOLITE Heat Treatment Furnace located at Level 1, Mechanical Building Block 17. The procedures for the H13 Tool Steel heat treatment processes are shown in Figure 11 as below:



*Figure 11: H13 Tool Steel Heat Treatment Process*

### 3.3 Procedure of FSW Process

For friction stir welding process, Bridgeport Milling Machine as shown in Figure 12 was used. Jig that has been fabricated earlier will be used during the process to support the plates.



*Figure 12: Bridgeport milling machine at Block N*

The welding process was facilitated with a jig as shown in Figure 13. The jig acts as platform to support the workpiece during FSW process.



*Figure 13: Aluminum plates will butt closely on jig and tightened with bolts and nuts*

Process of FSW using Bridgeport machine is described as follows:-

1. Two aluminum plates are butted together and secured on the jig with bolts and nuts. Gap between plates is closed using rubber hammer.
2. The jig is clamped to the Bridgeport Milling Machine.
3. Then they are ready to undergo FSW process as shown in Figure 14.

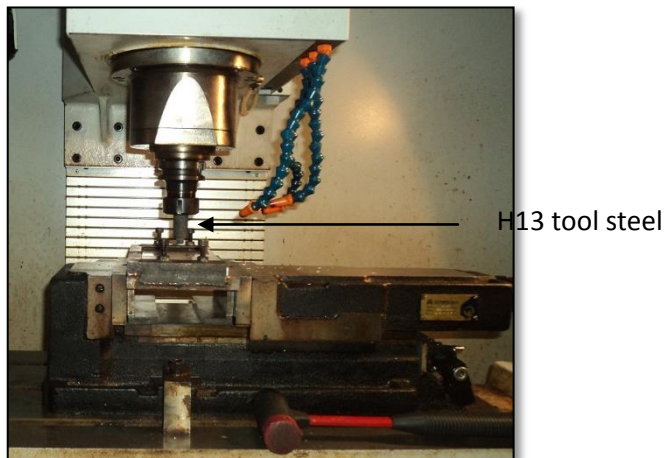

*Figure 14: H13 tool steel is ready for FSW*



*Figure 15: Workpiece undergo FSW process*

Parameter used for every sample is shown in Table 2 as follows:-

*Table 2: Parameter for FSW process*

<b>Plates/Sample name</b>	Sample 1	Sample 2	Sample 3	Sample 4	Sample 5
<b>Tool pin shape</b>	<b>Round</b>	<b>Round</b>	<b>Round</b>	<b>Triangular</b>	<b>Square</b>
<b>Plunge feed rate (mm)</b>	<b>10</b>	<b>10</b>	<b>10</b>	<b>10</b>	<b>10</b>
<b>Translational speed, S (mm/min)</b>	<b>50</b>	<b>75</b>	<b>100</b>	<b>50</b>	<b>50</b>
<b>Spindle speed, N (rpm)</b>	<b>1000</b>	<b>1000</b>	<b>1000</b>	<b>1000</b>	<b>1000</b>
<b>Penetration/Depth of plunge (mm)</b>	<b>8</b>	<b>8</b>	<b>8</b>	<b>8</b>	<b>8</b>
<b>Dwell time (sec)</b>	<b>12</b>	<b>12</b>	<b>12</b>	<b>12</b>	<b>12</b>

### 3.4 Specimen Preparation for Microstructure Testing

Metallography is a process of preparing metal surface of the specimen to reveal microstructural information. Metallographic Techniques consist of four main processes;-

- i. Cutting
- ii. Grinding
- iii. Polishing
- iv. Etching

#### 3.4.1 Cutting

Cutting is a process on removal of representative sample that contains information required. During cutting process, there is possibility of microstructure change of the material due to heating, chemical attack, or mechanical damage. For this sample, abrasive cutter as shown in Figure 16 was used for the cutting process. Although it may produce deformation damage as much as 1mm, the damage can be minimized by using thin cutting disks. Dimensions and portion of FSW plates cut for sample is shown in Figure 17.



*Figure 16: Abrasive cutter*

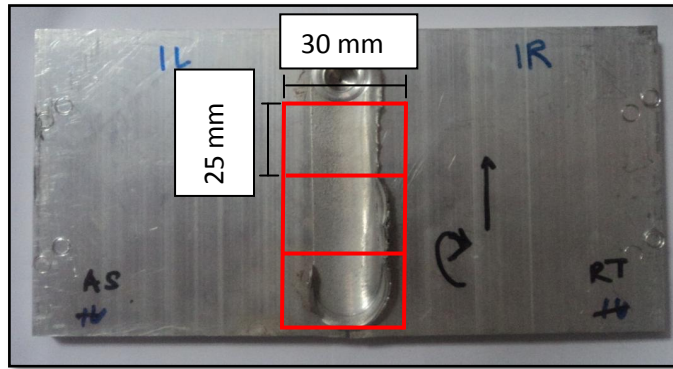

*Figure 17: Portion of FSW plates cut*

### **3.4.2 Grinding**

The purpose of grinding is to minimize thickness of the damaged layer from the sectioning process. Grinder machine used for this process is shown in Figure 18. Usually, it is done using rotating discs covered with SiC paper and using water as lubricant. Various available grades: 180, 240, 320, 400, 600, 1200 and 2400 grit (grains per square inch) were used as shown in Table 3. During grinding process, light pressure was applied at the centre of the sample. Throughout the grinding process, flatness of sample surface needs to be maintained.



*Figure 18: Grinder & polisher*



*Table 3: Grinding process parameter*

Step	Abrasive	Gradation	Lubricant	Rotational Speed (rev/min)
1	SiC	120	H <sub>2</sub> O	240
2	SiC	180	H <sub>2</sub> O	240
3	SiC	240	H <sub>2</sub> O	240
4	SiC	280	H <sub>2</sub> O	240
5	SiC	320	H <sub>2</sub> O	240
6	SiC	400	H <sub>2</sub> O	240
7	SiC	600	H <sub>2</sub> O	240
8	SiC	1200	H <sub>2</sub> O	240
9	SiC	2400	H <sub>2</sub> O	240

### **3.4.3 Polishing**

A process consisting of rotating discs covered with soft cloth (tri-cloth) impregnated with micro-particles of diamond or other media and lubricant. Lubricant used is Metadi fluid. Tri-cloth, Metadi fluid & diamond paste used are shown in Figure 19. Particles of two different grades will be used;-

- i. Coarser polish - typically with diamond particles 6 microns in diameter which should remove the scratches produced from the finest grinding stage.
- ii. Finer polish – typically with diamond particles 1 micron in diameter, to produce a smooth surface. The specimen needs to be washed with warm soapy water and alcohol first to prevent disc contamination.

Polishing is done until mirror-like surface is achieved. Steps involved in polishing are described as follows:-

- i. Tri-cloth is put on polisher. The tri-cloth is cleaned with pouring water while the polisher is rotating.
- ii. The tri-cloth is sprayed with Metadi fluid.
- iii. Diamond paste is smeared on sample surface.
- iv. Polishing is done until mirror-like image is achieved.



*Figure 19: Tri-cloth, Metadi fluid & diamond paste*

#### **3.4.4 Etching**

The purpose of etching is to reveal the microstructure of the metal through selective chemical attack. Other than that, it also important for revealing grain size, rolling direction, and welding zone. Apparatus used for etching process is shown in Figure 20. The specimen is etched by swabbing a cotton tip dipped in etchant, or immersing the sample with the etchant. The process should always be done in stages, beginning with light attack, an examination in the microscope and further etching only if required. An over-etched sample requires a repeat of the polishing procedure. For aluminum, etchant used is Keller's reagent. Keller's reagent consists of:-

- 190 ml distilled H<sub>2</sub>O
- 3 ml HCl

- 5 ml HNO<sub>3</sub>
- 2 ml HF

Steps involved in etching are described as follows:-

- i. Keller's reagent is mixed.
- ii. Reagent is applied on the sample surface by using cotton swab or by immersing about 15 to 25 seconds. Etching is done in stages to avoid over etching.
- iii. Sample is washed with running distilled water and followed with alcohol.
- iv. The sample is checked with optical microscope. If microstructure still can't be seen, etching process need to be repeated. Every time etching process is repeated, note that no need to repeat grinding and polishing process unless if the sample is over etch.

Once the surface gets enough etching, reflection of the microstructure can be seen with eyes. For etching time, although etching time propose in literature review is about 10-20 seconds, actual etching time until microstructure can be seen is more than 3 minutes. Note to use only freshly mixed reagent. There are few possible reasons on why etching time is more than suggested etching time:-

- i. Impurity of aluminum plates
- ii. Incorrect method use during grinding and polishing.



*Figure 20: Apparatus for etching process*

### 3.5 Microstructure Examination

For microstructural examination, Optical Microscope as shown in Figure 21 was used. For each sample, microstructure of intended area was examined with several magnifications, e.g. 10x, 50x, and 100x.

The surface to be examined optically should be perfectly flat and level. If not, then as the viewing area is moved across the surface, it will be difficult to have the whole field of view in focus.





*Figure 21: Optical Microscope*

### 3.5 List of Tools/equipments required

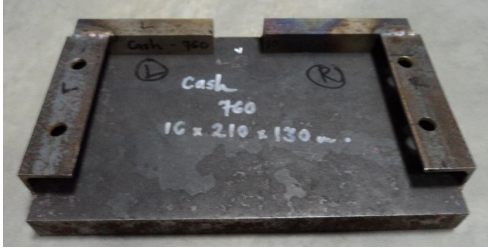
Table 4: List of tool/equipment required

NO	TOOLS/EQUIPMENT	FUNCTION
1	CNC machine	-To fabricate FSW tool.
2	FSW H-13 steel tool	- To fabricate FSW tool.
3	Aluminum plates	-To use in FSW process.
4	Abrasive Cutter	For sectioning FSW plates.
5	Bridgeport milling machine at Block N 	-For FSW process
6	Jig 	Clamping during FSW process
7	Grinder/Polisher	For grinding and polishing for sample preparation process.

		
<p>8</p>	<p>SiC Paper</p> 	<p>For grinding process</p>

### 3.6 Gantt Chart / Key Milestone

#### 3.6.1 FYP I

No	Detail/Week	1	2	3	4	5	6	7	8	9	10	11	12	13	14	15
1	Selection of Project Topic	■	▲													
2	Literature Review		■	■	■	■	■	■	■	■	■	■	■	■	■	■
3	Submission of Extended Proposal Report						▲									
4	Project Work: Study on the research scope and method		■	■	■	■	■	■								
5	Proposal Defense								■	■						
6	Project work continues: Further investigation on the project, tool fabrication and do modification if necessary										■	■	■	■	■	■
7	Submission of Interim Report															▲

Table 5: Gantt chart /Key Milestone for FYP I

#### 3.6.2 FYP II

No	Detail/Week	1	2	3	4	5	6	7	8	9	10	11	12	13	14	15
1	Project work continues	■	■	■	■	■	■	■								
2	Submission of progress report								▲							
	Project work continues								■	■	■	■	■			
	Pre-EDX											▲				
	Submission of draft report												▲			
3	Submission of dissertation (soft bound)													▲		
	Submission of Technical Paper													▲		
	Oral Presentation														▲	
4	Submission of Project Dissertation (Hard Bound)															▲

Table 6: Gantt chart /Key Milestone for FYP II

<b>Legend :-</b>	■	Process	▲	Suggested Milestone
------------------	---	---------	---	---------------------

## CHAPTER 4: RESULT & DISCUSSION

### 4.1 Heat Treatment of FSW Tool

The purpose of heat treatment is to have a sufficiently strong, tough and hard wearing, at the welding temperature tool material. Difference of FSW tools before and after heat treatment is shown in Figure 22 and Figure 23.



*Figure 22: FSW tools before heat treatment*



*Figure 23: FSW tools after heat treatment*

The tools have undergone heat treatment based on process stated. For triangular and rectangular tool pin, after one run on FSW machine, the shape of the tool change into round. This probably occurs due to friction during FSW process and this tool is not hard enough after being heat treated.



## 4.2 Friction Stir Welding Process

The friction stir welding process was done using CNC Milling Machine-BridgePort PowerPath 15. Three different tools with different parameter are used. Note that the spindle is moved clockwise. Note also for round tool, three samples were produced while for triangular and square tools, only one sample produced each. Details of FSW samples are shown in Table 7. In early planning, three samples will be produced form each tool pin shapes. Unfortunately, for triangle and rectangle tool pin profile, after first attempt of FSW, the shape of the tool pin changed into round shape. This is probably due to friction during the process. It also shown that heat treatment done can not withstand the friction during FSW process. For sample 4 and sample 5, sample was produced on first attempt of using the tool which was when the tools are still in triangular and square shape. Pictures of FSW plates are shown in Figure 24 until Figure 28.

*Table 7: Parameter for FSW process*

<b>Plates/Sample name</b>	Sample 1	Sample 2	Sample 3	Sample 4	Sample 5
<b>Tool pin shape</b>	<b>Round</b>	<b>Round</b>	<b>Round</b>	<b>Triangular</b>	<b>Square</b>
<b>Plunge feed rate (mm)</b>	<b>10</b>	<b>10</b>	<b>10</b>	<b>10</b>	<b>10</b>
<b>Translational speed, S (mm/min)</b>	<b>50</b>	<b>75</b>	<b>100</b>	<b>50</b>	<b>50</b>
<b>Spindle speed, N (rpm)</b>	<b>1000</b>	<b>1000</b>	<b>1000</b>	<b>1000</b>	<b>1000</b>
<b>Penetration/Depth of plunge (mm)</b>	<b>8</b>	<b>8</b>	<b>8</b>	<b>8</b>	<b>8</b>
<b>Dwell time (sec)</b>	<b>12</b>	<b>12</b>	<b>12</b>	<b>12</b>	<b>12</b>



Figure 24: Sample 1, FSW plates (Round tool, 50 mm/min)



Figure 25: Sample 2, FSW plates (Round tool, 75 mm/min)



Figure 26: Sample 3, FSW plates (Round tool, 100 mm/min)



Figure 27: Sample 4, plates (Triangular tool, 50 mm/min)

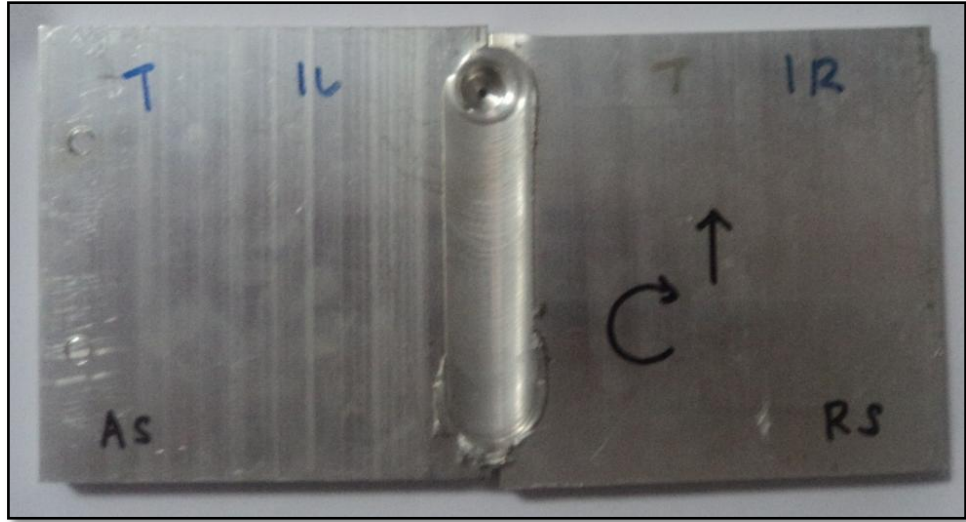
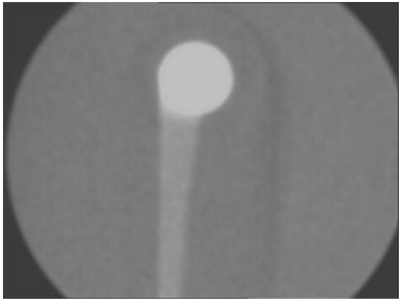
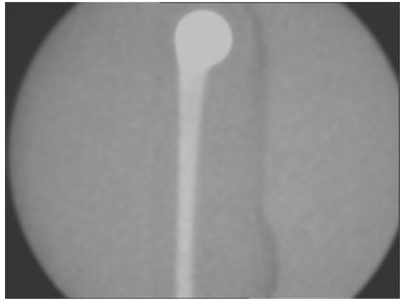
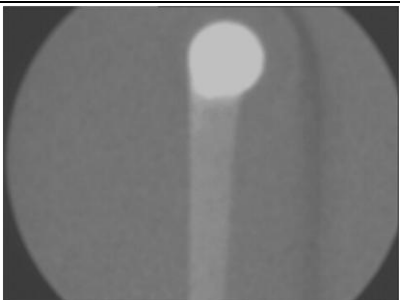



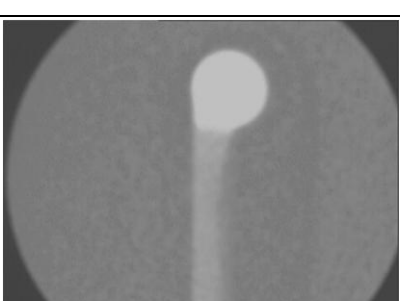



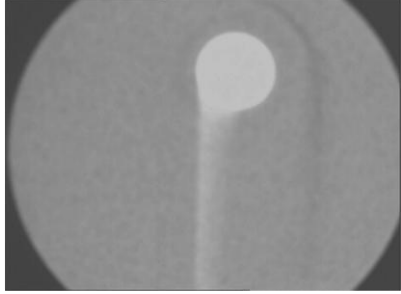

*Figure 28: Sample 5, FSW plates (Rectangular tool, 50 mm/min)*

**4.3 Internal Defects**

By using X-ray X-Tek machine, internal defects of the FSW plates can be examined. Results of the X-ray machine as shown in Table 8 as below:-

*Table 8: Internal defects of FSW plates*

Sample 1 (Upper)		Sample 1 (Full)	
Sample 2 (Upper)		Sample 2 (Lower)	
Sample 3 (Upper)		Sample 3 (Lower)	
Sample 4 (Upper)		Sample 4 (Lower)	

Sample 5 (Upper)		Sample 5 (Lower)	
------------------------	---	------------------------	---

From the results, we can observe that internal defects that occur to all FSW plates are worm-hole defects. It is a volumetric defect that is continuous. It occurs due to insufficient forming pressure under the tool shoulder, which prevents the material from consolidating. Mitigation of this defects is by tool design or weld parameter modification. If size of the defects is compared roughly, sample that has the smallest worm-hole defects is sample 5.

**4.4 Microstructural Region Analysis**

For microstructural region analysis, initially, the author wants to take the whole microstructural region as shown on Figure 29. The biggest spot that optical microscope can capture is shown in Figure 30 and its image is shown in Figure 31. Due to this limitation, the whole microstructural region can not be captured.

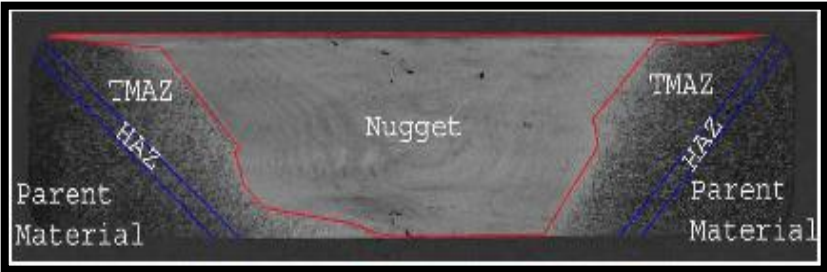

*Figure 29: Expected Microstructural Region [10]*

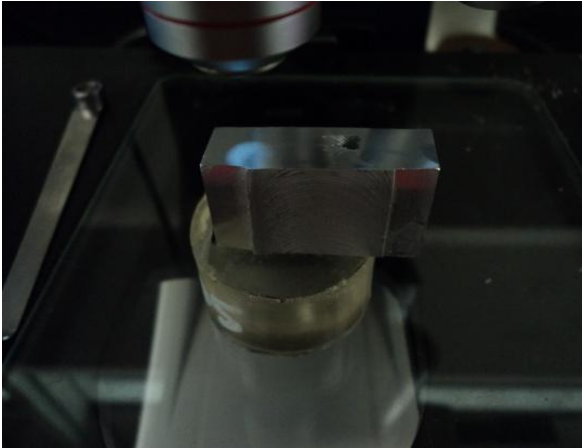

*Figure 30: Biggest spot on sample that optical microscope can capture*

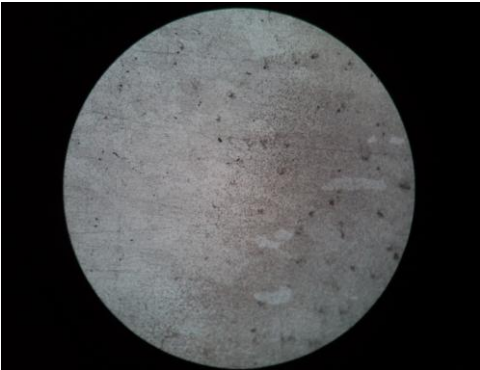
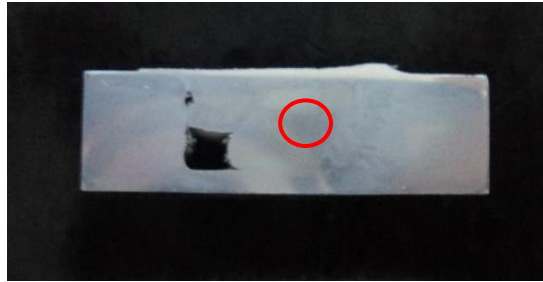

*Figure 31: HAZ on Sample 5 Microstructural Region*

#### 4.5 Microstructure Analysis

All the joints fabricated in this investigation were analyzed using optical microscope to reveal the quality of FSW regions. Based on available literature, to compare quality of FSW plates, a few literatures suggest that square tool will have the best microstructure performance [4] [5].

For every sample, optical microscope was used to capture microstructure images of weld nugget region as shown in Figure 32.



*Figure 32: Region on samples where microstructure image captured using Optical Microscope*

From optical microscope result, comparison of the result is done based on different tool pin shapes with same parameters (Sample 1, Sample 4, and Sample 5) and based on same tool pin shapes with different parameters (Sample 1, Sample 2, Sample 3). Comparison between round tools with different translational speed is shown in Table 9 and Table 10 while comparison between different tools pin shapes with same translational speed is shown in Table 11 and Table 12.



Table 9: 50x magnifications for round tool with different translational speed







Magnification	50 X
Sample 1 (Round tool/ translational speed=50 mm/min)	
Sample 2 (Round tool/ translational speed=75 mm/min)	
Sample 3 (Round tool/ translational speed=100 mm/min)	

Table 10: 100x magnifications for round tool with different translational speed

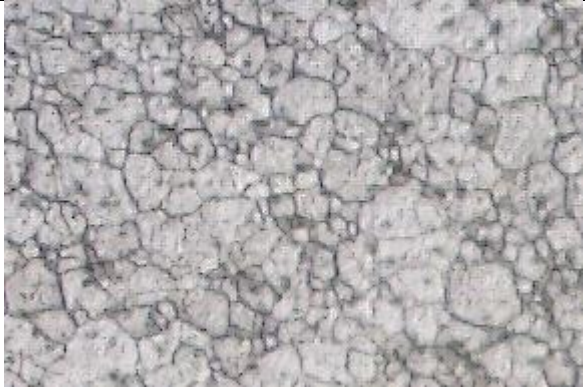
Magnification	100 X
Sample 1 (Round tool/ translational speed=50 mm/min)	
Sample 2 (Round tool/ translational speed=75 mm/min)	
Sample 3 (Round tool/ translational speed=100 mm/min)	

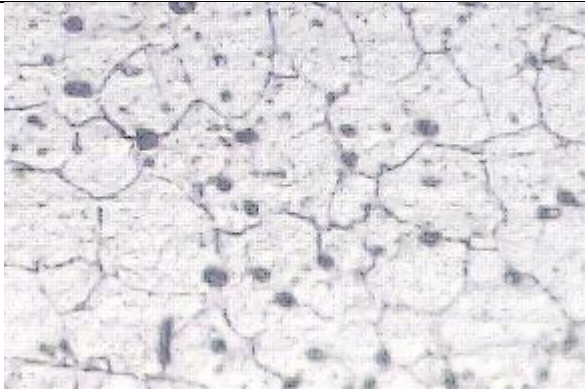
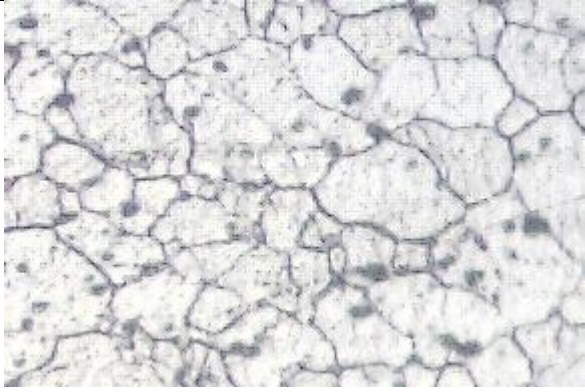
*Table 11: 50x magnifications for different tools pin shape with same translational speed*

Magnification	50 X
<p>Sample 1 (Round tool/ translational speed=50 mm/min)</p>	
<p>Sample 4 (Triangular tool/ translational speed=50 mm/min)</p>	
<p>Sample 5 (Rectangular tool/ translational speed=50 mm/min)</p>	

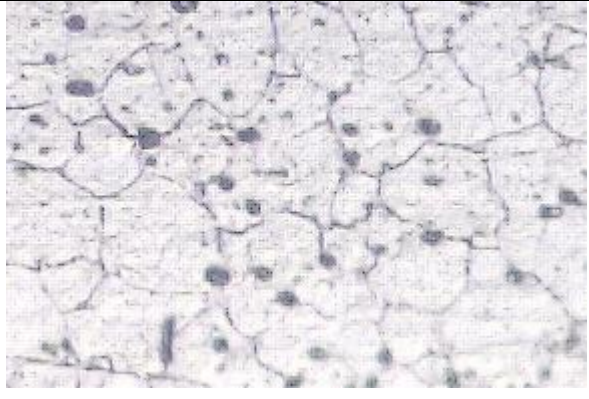
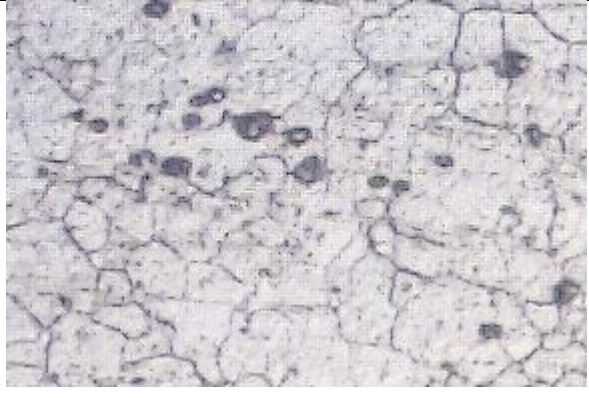
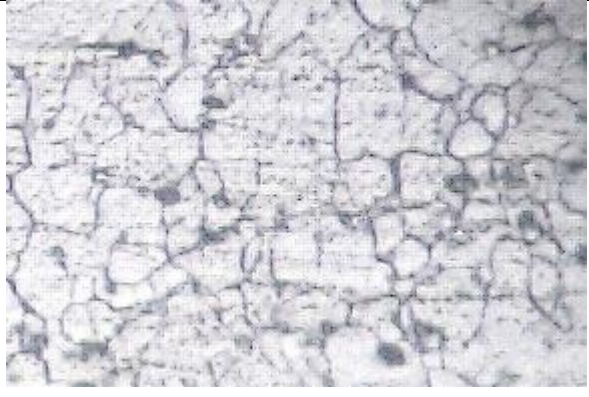

*Table 12: 100x magnifications for different tools pin shape with same translational speed*

Magnification	100 X
Sample 1 (Round tool/ translational speed=50 mm/min)	
Sample 4 (Triangular tool/ translational speed=50 mm/min)	
Sample 5 (Rectangular tool/ translational speed=50 mm/min)	

From optical microscope result, comparison of the result is done based on different tool pin shapes with same parameters (Sample 1, Sample 4, and Sample 5) and based on same tool pin shapes with different translational speed (Sample 1, Sample 2, Sample 3). Roughly, if we compare between tool pin shape (Sample 1-Round, Sample 4-Triangular, Sample 5-Triangular), Sample 5 shown smallest grain size. If we compare between tool

pin shape (Sample 1-Round, Sample 4-Triangular, Sample 5-Triangular), Sample 5 shown smallest grain size. Smaller grain size is preferable because it result in more grain boundaries that strengthen the material. Grain boundaries increase the strength of aluminum by resisting the movement of dislocations in the microstructure. Therefore, more force is required to deform a material when it has large quantity of grain boundaries. From this research, we can conclude two things:-

- i. For translational speed used, higher translational speed will effect in smaller grain size. Thus, higher translational speed is preferable.
- ii. Out of all tool pin shapes, the joint fabricated using rectangular tool pin profiled shows better microstructure result.

## CHAPTER 5: CONCLUSIONS AND RECOMMENDATIONS

As discussed in previous chapters, FSW produces welds using a rotating, non consumable welding tool inserted into the abutting edges of two plates to be joined and after that traversed along the joint line. The dependence on the friction and plastic work for the heat source prevent significant melting in the work piece. The reduced welding temperatures make possible lower distortion and residual stresses, enabled improved fatigue performance. In typical FSW process, it uses fully mechanized process. This will increase the cost of the equipment but at the same time reduces the degree of operator skill required.

In FSW, a good weld quality could be defined based on the strength of the joint. To fulfill the desired strength, proper welding parameters should be selected. The tool should be designed to give the desired material flow and heat generation under the constraints given by the welding machine. From this research, we can conclude two things:-

- i. For translational speed used, higher translational speed will effect in smaller grain size. Thus, higher translational speed is preferable.
- ii. Out of all tool pin shapes, the joint fabricated using rectangular tool pin profiled shows better microstructure result.

### 5.1 Limitation in this project

- i. From this project, internal defects of the FSW plates have been identified. All plates have same defect which is worm-hole defect due to inappropriate parameter. Due to time constraints, we cannot change the parameter in order to get better results.
- ii. For microstructure analysis, earlier plans; the analysis will be done using optical microscope and Scanning Electron Microscope (SEM) or Field Emission Scanning Electron Microscope (FESEM) machine. Along the way, both SEM and FESEM were not working for quite some time. The solution taken is that to try using optical microscope first. Although the result of optical microscope is

not as accurate as SEM, it still able to shows microstructure of the sample. Optical microscope available is only in black and white.

- iii. Other problem that occurs is about the square and triangular tool that changed shape into round tool after first run on the machine. This occurs due to friction during the process and the tool cannot withstand it. Due to this, only one sample can be produced for triangular and rectangular tool pin shape. Since only 5 samples can be produced out of 3 tools, the result is not very conclusive.

## **5.2 Recommendation**

- i. In this project, rectangular and triangular tool changes in shape after only one run. To overcome this problem, we can:-
  - Use harder material for FSW tools.
  - Study different parameter for heat treatment process.
  - Prepare at least one round tool pin shape and 3 triangular and rectangular tool pin shape so that we can prepare at least three samples with different translational speed for each tool pin profile.
- ii. Due to time constraint, analysis of result only can be done based on observation of microstructure size. To obtain more accurate result, analysis of result can be done based on quantitative measure. For example, exact grain size can be calculated using Hall-Petch equation.

