



UNIVERSITI
TEKNOLOGI
PETRONAS

FINAL EXAMINATION MAY 2024 SEMESTER

COURSE : CCM5123 – PRINCIPLES OF HAZARD ANALYSIS & RISK MANAGEMENT

DATE : 4 AUGUST 2024 (SUNDAY)

TIME : 9:00 AM – 12:00 PM (3 HOURS)

INSTRUCTIONS TO CANDIDATES

1. Answer **ALL** questions in the Answer Booklet.
2. Begin **EACH** answer on a new page in the Answer Booklet.
3. Indicate clearly answers that are cancelled, if any.
4. Where applicable, show clearly steps taken in arriving at the solutions and indicate **ALL** assumptions, if any.
5. **DO NOT** open this Question Booklet until instructed.
6. **Attach Appendix A in your answer booklet.**

Note :

- i. There are **SIX (6)** printed pages in this **double-sided** Question Booklet including the cover page and appendix.

1. To date, numerous process safety incidents have been reported both locally and globally, highlighting the ongoing challenges in maintaining industrial safety standards. These incidents range from minor leaks and equipment malfunctions to catastrophic explosions and widespread chemical releases.

a. Consider a recent process safety incident where a significant leak of a hazardous substance occurred, leading to an explosion and multiple injuries. Evaluate the incident according to the '**Anatomy of Incidents**' framework.

[10 marks]

b. Based on your evaluation, propose a set of recommendations to enhance the existing control measures and explain how each recommendation would mitigate the risk of a similar incident occurring in the future. Prioritize these recommendations according to the hierarchy of controls.

[15 marks]

2. You are a safety engineer at a chemical manufacturing plant. Your plant has been operational for several years, but due to recent incidents in the industry and new regulatory requirements, your company has decided to conduct a comprehensive Hazard and Operability Study (HAZOP) for one of its critical processes – the separation main products in a flash drum as shown in **FIGURE Q2**. The purpose of the flash drum is to separate multiple mixture of mostly A and B plus some other heavy components to produce main products leaving the top at 90 mol% of A. Steam at 5 bar is used to bring the temperature at the desired saturation temperature.

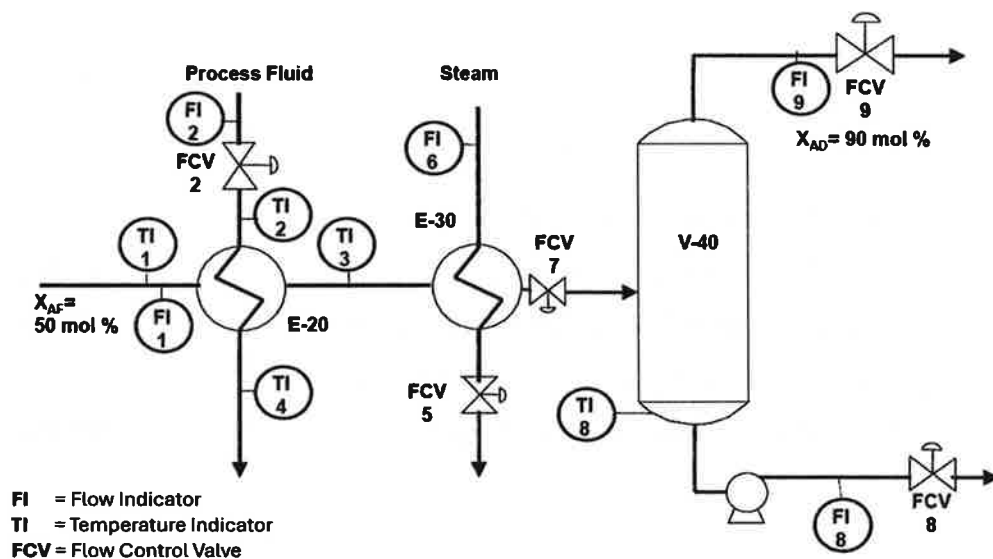

FIGURE Q2 Flash Drum System

For all applicable process parameters, perform a HAZOP study on the process using **THREE (3)** relevant guide words and propose possible causes, consequences, and actions for each guide word.

[25 marks]

3. XYZ Chemical Corporation is experimenting with acetone (C₃H₆O) as a potential solvent in their manufacturing process. The chemical is stored in a storage tank maintained at 80°F. The tank's vapor space is inerted with pure carbon dioxide to a total pressure of 1 inch of water gauge. It is assumed that the vapor space is saturated with acetone vapor. Upon escaping, the inerted vapours mix with air, resulting in a mixture composed of 19.5% acetone and 80.5% carbon dioxide. The relevant data for acetone is given in **TABLE Q3**. The general combustion reaction is given as follows:

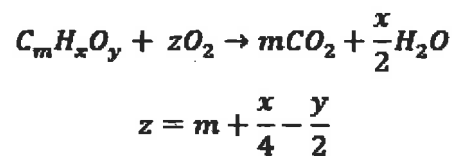

TABLE Q3 Flammability Characteristics of Acetone

Lower Flammability Limit (LFL)	2.6%
Upper Flammability Limit (UFL)	12.8%
Limiting Oxygen Concentration (LOC)	10.0%
Lower Flammability Limits in Pure Oxygen	3.0%
Upper Flammability Limits in Pure Oxygen	57.0%

An initial evaluation by the research team concluded that the mixture was not flammable. As a safety consultant, your task is to validate these results and determine under what conditions the mixture might become flammable using Flammability Diagram in **Appendix A**. If the mixture is found to be flammable, propose strategies to prevent accidents in the future.

[25 marks]

4. You are the Health, Safety, and Environment (HSE) Officer at a chemical manufacturing plant. The plant has recently undergone a risk assessment, and **TABLE Q4** provides the frequency or probability of various events that could occur during an incident. A scenario has been given to you to solve:

“At 2:00 AM on a Tuesday, an explosion occurs at the chemical plant. The explosion has the potential to start a fire. If a fire starts, the effectiveness of the sprinkler system and the fire alarm system will play crucial roles in mitigating the damage.”

TABLE Q4 Frequency or probability for each event

Event	Frequency or probability (x 10 ⁻² per year)
Explosion	1.0
Start of fire	0.8
The sprinkler is not functioning	0.01
The fire alarm is not activated	0.001

- a. Based on the given scenario, predict the outcomes of the incident and estimate the net frequency for each of the event outcomes.

[15 marks]

- b. Propose additional potential events to the existing incident in **part (a)** that might affected the net frequency. Compare and comment this new event's net frequency with the original scenario.

[10 marks]

- END OF PAPER -

APPENDIX A

Detach the following Flammability Diagram sheet and attach with the answer booklet, where necessary.

