

**REAL-TIME ARRHYTHMIA MONITORING AND DETECTION SYSTEM
FOR REMOTE DIAGNOSIS**

By

NUR LAILA BINTI SAARANI

FINAL PROJECT REPORT

Submitted to the Department of Electrical & Electronic Engineering
in Partial Fulfillment of the Requirements
for the Degree
Bachelor of Engineering (Hons)
(Electrical & Electronic Engineering)

Universiti Teknologi PETRONAS
Bandar Seri Iskandar
31750 Tronoh
Perak Darul Ridzuan

© Copyright 2012

by

NUR LAILA BINTI SAARANI, 2012

CERTIFICATION OF APPROVAL

REAL-TIME ARRHYTHMIA MONITORING AND DETECTION SYSTEM FOR REMOTE DIAGNOSIS

by

NUR LAILA BINTI SAARANI

A project dissertation submitted to the
Department of Electrical & Electronic Engineering
Universiti Teknologi PETRONAS
in partial fulfilment of the requirement for the
Bachelor of Engineering (Hons)
(Electrical & Electronic Engineering)

Approved:

Dr. Fawnizu Azmadi Hussin
Project Supervisor

**UNIVERSITI TEKNOLOGI PETRONAS
TRONOH, PERAK**

September 2012

CERTIFICATION OF ORIGINALITY

This is to certify that I am responsible for the work submitted in this project, that the original work is my own except as specified in the references and acknowledgements, and that the original work contained herein have not been undertaken or done by unspecified sources or persons.

NUR LAILA BINTI SAARANI

ABSTRACT

Arrhythmia is a kind of heart disease with the implication of abnormal heart beat rhythm; either it is too fast, too slow or with an irregular rhythm which can lead to death if the patient did not go for appropriate treatment within the time. The symptoms of this disease is atypical, thus continuous monitoring system is needed in order to pre-detect the disease followed by earlier treatment so that unwanted end of someone life can be avoided.

This project is proposing a real-time, continuously monitoring and detection system for arrhythmia patient which will allow the collected data from patient being analyzed on the exact time. Throughout this paper, the proposed system will be designed for home-based usage with remote diagnosis feature to give more comfort to the patient and flexibility to the doctor or cardiologist. The system will be programmed in LabVIEW; a graphical programming software from National Instruments with the ECG sensor attached to the PC via DAQ board to allow real-time data collecting and analysis as well as the add-on feature to enable the web-based monitoring system for remote observation.

ACKNOWLEDGEMENTS

First and foremost, I would like to express my sincere gratitude to my supervisor, Dr. Fawnizu Azmadi Hussin for his supervision and constant support. His invaluable help of constructive comments and suggestions throughout the whole two semesters have contributed to the success of this project.

Special thanks to National Instruments and the Application Engineer Team Leader, Mrs. Sumayyah Mustafa for the great help in rendering the LabVIEW software and related hardware.

I also would like to thank all my friends who have directly or indirectly involved in this project. Thank you for your support and attention whenever I need shoulders to cried on.

Last but not least, endless thanks and love to my beloved parents and family members for their continuous supportive spirit, inspiration and motivation after all these years.

TABLE OF CONTENTS

| | |
|---|-----|
| LIST OF TABLES | ix |
| LIST OF FIGURES | x |
| LIST OF ABBREVIATIONS | xii |
| CHAPTER 1 INTRODUCTION..... | 1 |
| 1.1 Background..... | 1 |
| 1.2 Problem Statement | 3 |
| 1.3 Objectives | 3 |
| 1.4 Scope of Study | 3 |
| 1.5 LabVIEW | 4 |
| CHAPTER 2 LITERATURE REVIEW | 6 |
| 2.1 Real-Time Continuous Cardiac Monitoring System..... | 6 |
| 2.2 A Fast and Accurate Method for Arrhythmia Detection..... | 7 |
| 2.3 Real-Time Algorithm for a Mobile Cardiac Monitoring System to Detect Life Threatening Arrhythmia | 8 |
| 2.4 Wearable ECG Recording System for Continuous Arrhythmia Monitoring in Wireless Tele-Home-Care..... | 10 |
| CHAPTER 3 METHODOLOGY | 12 |
| 3.1 Project Diagram | 12 |
| 3.2 Flow Chart | 12 |
| 3.3 Project Activities..... | 13 |
| 3.4 Tools and Equipment | 13 |
| 3.5 Gantt Chart | 14 |
| CHAPTER 4 RESULTS | 15 |
| 4.1 Research on ECG Signal Behavior | 15 |
| 4.2 ECG Pre-processing | 16 |
| 4.2.1 Baseline Wandering Removal Through Wavelet Transform Approach..... | 17 |
| 4.2.2 Wideband Noise Suppression Through Wavelet Denoise | 17 |
| 4.3 Validation of Arrhythmia Detection Algorithm | 19 |
| 4.3.1 Calculation of heart beat per minute | 20 |
| 4.3.2 QRS time interval | 21 |

| | |
|--|----|
| 4.4 Hardware Integration | 22 |
| 4.5 Alarm System and Auto Data Logging | 24 |
| 4.6 Web-Based Monitoring Feature | 26 |
| CHAPTER 5 CONCLUSION | 29 |
| RECOMMENDATIONS | 29 |
| REFERENCES | 30 |

LIST OF TABLES

| | |
|--|----|
| Table 1: Gantt chart | 14 |
| Table 2: Typical lead II ECG features and their normal values for a healthy adult | 16 |
| Table 3: The accuracy of algorithm used based on 6 seconds strip of ECG..... | 22 |

LIST OF FIGURES

| | |
|--|----|
| Figure 1: Example of ECG signal for 1 heart beat | 2 |
| Figure 2: Example of tachycardia | 2 |
| Figure 3: Example of bradycardia | 2 |
| Figure 4: Example of premature contraction | 2 |
| Figure 5: Example of fibrillation | 2 |
| Figure 6: ecg_QRS_detector by Wavelet Peak Detection function code | 5 |
| Figure 7: ecg_feature_extraction_based_on_QRS function code | 5 |
| Figure 8: The flowchart of VT/VF detection algorithm | 9 |
| Figure 9: The illustrated diagram for the wireless tele-home-care system | 11 |
| Figure 10: The P-QRS-T wave | 15 |
| Figure 11: Typical ECG signal processing flowchart | 16 |
| Figure 12: Using the WA Detrend function code to remove the baseline Wandering | 17 |
| Figure 13: The baseline wandering removal result | 17 |
| Figure 14: Wideband noise removal by applying the Undecimated Wavelet Transform (UWT) | 18 |
| Figure 15: The result of Wideband Noise Removal using UWT denoising | 18 |
| Figure 16: The ECG graph paper | 19 |
| Figure 17: A glimpse of the coding behind ECG feature extraction function code.. | 19 |
| Figure 18: The code to calculate the beats per minute | 20 |
| Figure 19: Result of calculating beats per minute in LabVIEW | 20 |
| Figure 20: Marking the 3 small boxes with Vernier caliper | 21 |
| Figure 21: LabVIEW programming for QRS time interval | 21 |
| Figure 22: Result of QRS interval in LabVIEW | 21 |
| Figure 23: The ECG sensor from Vernier Instruments | 22 |
| Figure 24: ECG sensor connected to the PC via DAQ board | 22 |
| Figure 25: The connection from the PROTO Vernier connector to the DAQ board. | 23 |
| Figure 26: The placement of the ECG electrode patches on the patient | 23 |
| Figure 27: Acquisition of live ECG data through ECG sensor | 24 |
| Figure 28: The algorithm for alarm system | 24 |
| Figure 29: The GUI for alarm system | 25 |

| | |
|---|----|
| Figure 30: The function code for data logging | 25 |
| Figure 31: The logged data of the wide QRS interval occurrence | 26 |
| Figure 32: Access to web publishing tool application | 27 |
| Figure 33: Web publishing setup | 27 |
| Figure 34: The GUI for the complete system launched on the specific URL link... | 28 |
| Figure 35: The LabVIEW programming for the complete system | 28 |

LIST OF ABBREVIATIONS

| Abbreviation or symbol | Term |
|-------------------------------|-------------------------------|
| bpm | Beats per minute |
| DAQ | Data acquisition |
| ECG | Electrocardiogram |
| NI | National Instruments |
| URL | Uniform Resource Locator |
| UWT | Undecimated Wavelet Transform |
| VF | Ventricular Fibrillation |
| VT | Ventricular Tachycardia |
| WA | Wavelet Analysis |

CHAPTER 1

INTRODUCTION

1.1 BACKGROUND

Arrhythmia means loss of rhythm, which originates from the Greek word *rhythmos* (rhythm) and the Greek prefix *a* (means 'loss') [1]. Arrhythmia is defined as an abnormal rhythm or irregularity of the heartbeat and can be classified into four major classes which are tachycardia (too fast heart beat), bradycardia (too slow heart beat), premature contraction (too early heart beat) and fibrillation (too irregularly heart beat) [2]. Tachycardia refers to the heart beat greater than 100 bpm (beats per minute) while bradycardia is slower than 60 bpm [1].

Arrhythmia occurs when the electrical impulses to the heart that coordinates beats are not working properly; cause too slow beats, too fast or inconsistently [2]. Most arrhythmias are benign, but some cases can be serious and may lead to death. During an arrhythmia, the heart may not be able to pump enough blood to the body which can bring damage to the brain, heart and other organs as well as induce potentially fatal symptoms due to the lack of blood flow.

There are few types of arrhythmia such as bradyarrhythmia, atrial fibrillation, premature atrial contractions (PAC), premature ventricular contractions (PVC), long QT syndrome, and so on but the most critical type is ventricular fibrillation (VF) which frequently triggered by ventricular tachycardia (VT) that can be fatal if the patient did not get proper treatment within minutes [2][3].

The indications of arrhythmia are not regular; the signs may and may not be detected during the routine examination, while any symptom occurs does not really mean there is a serious problem. It is possible that patients with life threatening arrhythmias do not have symptoms at all while others with symptoms may not have a crucial problem.

Therefore, a continuous monitoring system of the electrical activities of the heart is vital in order to pre-observe if there is any sign of arrhythmia. The electrical activities generated by the heart can be observed and diagnosed through few methods like electrocardiogram (ECG), Holter monitor, Event monitor, stress test, echocardiogram, and cardiac computerized tomography [4].

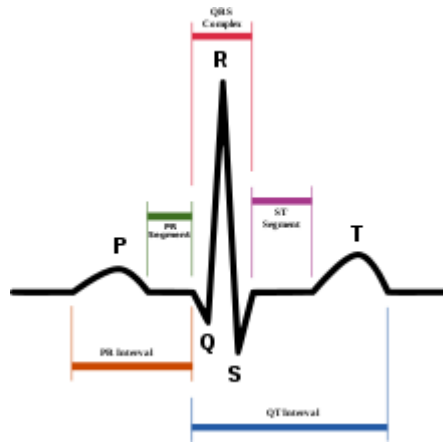

Figure 1: Example of ECG signal for 1 heart beat

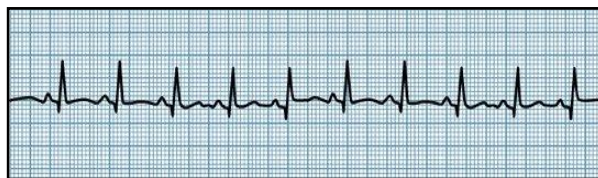

Figure 2: Example of tachycardia



Figure 3: Example of bradycardia



Figure 4: Example of premature contraction



Figure 5: Example of fibrillation

1.2 PROBLEM STATEMENT

An electrocardiogram (ECG) is a hospital based monitoring process by placing electrodes on the skin to monitor the electrical activity of the heart. This test is comprehensive, it can detect any abnormal rhythms present and if there is any damage to the heart muscle but it is not portable since it is only conducted during the routine test in the hospital. It will be a troublesome if there is no sign of arrhythmia happens during the test as the patient needs to keep coming to the hospital for further check-ups.

Hence, there are mobile arrhythmia monitoring device invented for outdoor usage and able to record the heart's activity for longer period which are known as Holter monitor and Event monitor. Both monitor are basically an ECG portable device that can be worn for a day or more to record the heart electrical activity with sensors (electrodes) attached to the chest.

The limitation of these device is they are not a real time system since the doctor or cardiologist can only diagnose the disease once the patient return the device to them with the recorded data. This is not good as the result may be late while the patient is already in critical condition.

1.3 OBJECTIVES

The main purpose of this paper is to improve the current system of monitoring and detecting the signs of arrhythmia disease by developing a real-time monitoring and auto-analysis system to detect the occurrence of the disease. Previous method seems to be less reliable thus new methods is vital to cover up this matter with the help of current enhanced technology. Result from this project is perhaps can help the health field in pre-detecting the disease so that patients can get earlier treatment.

1.4 SCOPE OF STUDY

This project will evolve on creating a new system to analyze and diagnose the heart electrical activities to detect any arrhythmia disease. The main focus of this

project will be on the real-time heart beat data collecting and remotely analyzing features through web-based monitoring system. The data will be collected from ECG sensor attached to the patient's body and transfer to the analyzing PC via analog input port on DAQ board. Then the transferred data will be analyzed through signal processing method inside LabVIEW to detect if the patient faces any arrhythmia problem.

The first step of detecting any arrhythmia in this project will be based by identifying if there is any bradycardia or tachycardia sign occur while analyzing the collected data from the patient. Then this project proposes further development to detect the most critical arrhythmia; the ventricular tachycardia (VT) with the help of visualization from the expert in the health centre.

The system then will be further programmed to enable the web-based monitoring. If there is any abnormality happens, an alarm will be popped out to alert the particular health centre through the website. All of the output can be observed through any PC or Smartphone by just browse the specific website link created from the coding in LabVIEW. Once the signs of arrhythmia happen, the system will log the occurred times and the related parameter values for future reference.

1.5 LabVIEW

LabVIEW is graphical programming software owned by National Instruments (NI). It has a number of modules and toolkits to support various applications including the pre-processing of ECG signal and QRS feature extraction through the Digital Filter Design, Advanced Signal Processing and NI Biomedical toolkits.

In NI Biomedical toolkit, there are built-in function codes that can be used to analyze the ECG signal such as the `ecg_QRS_detector` by Wavelet Peak Detection and `ecg_feature_extraction_based_on_QRS`.

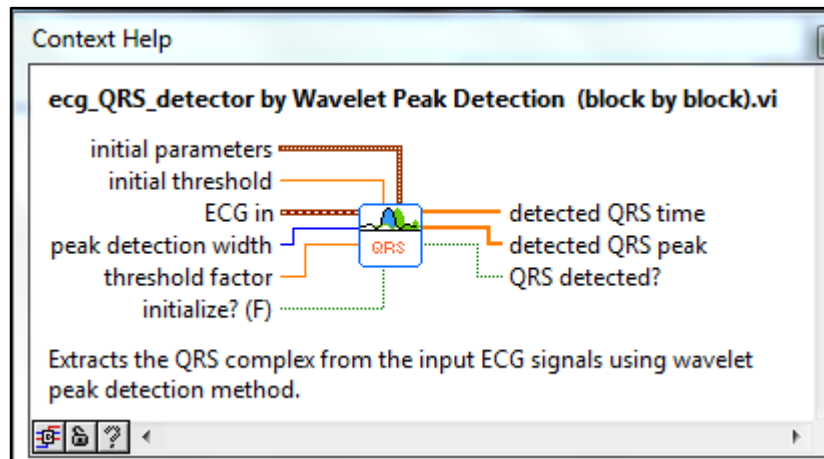

Figure 6: ecg_QRS_detector by Wavelet Peak Detection function code

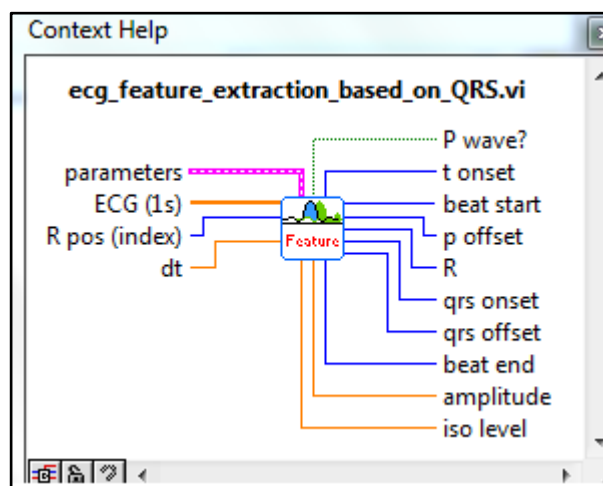

Figure 7: ecg_feature_extraction_based_on_QRS function code

The ecg_QRS_detector by Wavelet Peak Detection function code is used to detect the position of the QRS wave in term of time while the ecg_feature_extraction_based_on_QRS function code is used to extract other parameters such as the P wave and T wave.

CHAPTER 2

LITERATURE REVIEW

2.1 REAL-TIME CONTINUOUS CARDIAC MONITORING SYSTEM

Real-time continuous cardiac monitoring systems represent the newest form of external ambulatory monitors developed to overcome the limitations of Holter monitors and standard external loop recorders (ELRs) or also known as Event monitor. It is worn continuously and has similar size with the standard ELR. This system automatically records and transmits arrhythmic event data from ambulatory patients to an attended monitoring station.

The reading data also can be recorded through patient-triggered activation through technology which is referred as the mobile or real-time cardiac telemetry systems (MCOT). Through this device, cardiac activities are continuously monitored by 3 chest electrodes that are attached to a pager-sized sensor [5]. The sensor then transmits the collected data to a portable monitor with a built-in cell phone and need to be within a certain range of proximity with the patient to receive the signals.

The monitor is able to analyze the rhythm data continuously and automatically with the equipped software. The monitor automatically transmits the recorded data once arrhythmia is detected by the algorithm through trans-telephonic (by wireless network or land phone line) to a central monitoring station for further analysis. Trained staff members at the monitoring station will analyze the live incoming data and contact the referring physician and patient according to the predetermined criteria [6].

When the patient is away from home, the built-in cellular phone allows data transmission from the monitor to the central station. The key feature of this system includes continuous real-time ECG monitoring for a longer period of time (up to 30 days) without the requirement of patient activation and transmission of data. The data is transmitted and analyzed immediately by the technicians who can contact the patient and the physician immediately if an urgent intervention is needed.

2.2 A FAST AND ACCURATE METHOD FOR ARRHYTHMIA DETECTION

Among various types of arrhythmia, they are 5 to 6 which are considered important according to the vitality and weight bearing such as the ventricular tachycardia ventricular fibrillation (VT/VF), premature ventricular contracture (PVC), right bundle branch block (R or RBBB) and left bundle branch block (L or LBBB) [7]. There have been many methods to diagnose different types of arrhythmia, for example by extracting amplitudes and duration of each wave [8]. Primary methods were based on time and frequency domain analysis of ECG signal [8][9].

There are newer approaches such as the wavelet domain analysis of signals, the ECG data modeling by using Hermitian, Gaussian RBF [9][10][11] or spline basis functions and classifying coefficients for each one. To classify the coefficients [9][10][11][12], many classifiers is used like the support vector machine [10][11], fuzzy, neurofuzzy, neural network and etc.

Instead of directly modeling the ECG, some papers have used Hermitian modeling of higher order statistics of the ECG signal to achieve robustness to failures in QRS detection. Here, a multi-stage algorithm for arrhythmia analysis is proposed to classify each arrhythmia using a specified method. Contrary to others, different methods are used for modeling different types of arrhythmia.

a) Multi-stage Potential to Classify different types of arrhythmia

A combination of two methods: the classical ECG modeling through Hermite decomposition or RBF and observation by an expert clinician through knowledge based analysis to detect ECG arrhythmia more accurately [7].

b) Non-Uniform Sampling

Contribute in great reduction of the rate of calculation and computation which is necessary to model or classify a signal. Reduction in the number of input samples is theoretically needed to fully reconstruct a signal using its degree of freedom instead of the traditional Nyquist frequency.

c) FRI (Finite Rate of Innovation)

Finite Rate of Innovation is a brand new method to perform perfect reconstruction of non-band limited signals using their rate of innovation, irrespective of their Nyquist frequency. Previous approaches in non-uniform sampling satisfy Nyquist theorem but in FRI sampling each signal is thought as a summation of some unknown basis functions from which the primary signal can be obtained. Considering the linearity which is present in some types of arrhythmia (LBBB, RBBB and normal signals), it is noteworthy that FRI can be a good method of sampling of these types of signals [12].

2.3 REAL-TIME ALGORITHM FOR A MOBILE CARDIAC MONITORING SYSTEM TO DETECT LIFE-THREATENING ARRHYTHMIAS

Ventricular tachycardia and fibrillation (VT/VF) are the two main types of life threatening arrhythmias. VT refers to the heart beating too quickly, resulting in a reduced cardiac output. If VT occurs for a certain period of time, it may induce the VF which is the main cause of sudden cardiac death problems. The probability of survival for a human who has a VF attack outside of the hospital is 2~25% [13].

For that reason, VT/VF early detection is crucial and indispensable. In latest years, detection algorithms for VT/VF have been applied by make use of the time and frequency domain characteristics of the cardiac electric signal [14][15]. Support vector machines (SVM) and fuzzy neural networks (FNN) can be effectively applied as major detection and predictive rule generation tools for this type of problem [16][17].

A new VT/VF detection algorithm includes both pre-detection processing and main detection processing. Through pre-detection processing, the VT/VF signals are detected by a threshold value obtained by the Number of Same Limit Values (NSLV) method while the main detection processing applies the fuzzy neural network to detect the occurrences of VT/VF [18]. The input features of the fuzzy neural network are extracted by several effective methods.

A new VT/VF detection algorithm is used to distinguish VT/VF from normal sinus rhythm (NSR) based on the FNN with the weighted fuzzy membership function (NEWFM) [21]. NEWFM is a supervised classification neural fuzzy system using the

bounded sum of weighted fuzzy membership functions (BSWFMs) [21]. Figure 2 shows the VT/VF detection algorithm's structure, which includes 5 steps [22].

Step 1: Collects 8 seconds of an ECG signal for further analysis.

Step 2: Pre-detection process, where VT/VF signals with incomplete CUDB annotation are detected in 8-second signals.

Step 3: Filters the 8-second ECG signals with the Haar wavelet transform.

Step 4: Extracts 14 initial features, which are obtained by several effective extraction methods, from the results of the wavelet transform.

Step 5: The NEWFM detects the VT/VF with input features.

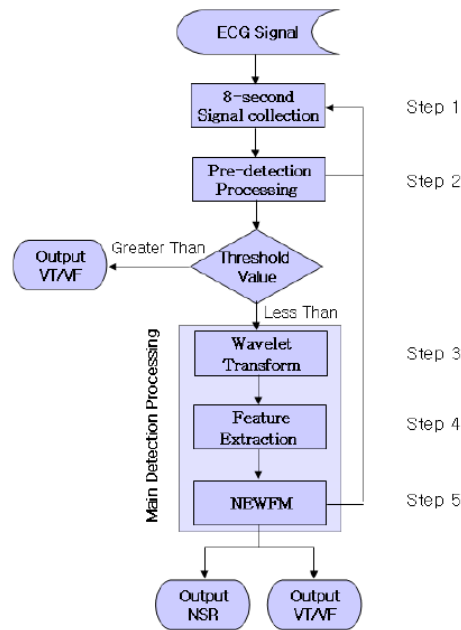

Figure 8: The flowchart of VT/VF detection algorithm

2.4 WEARABLE ECG RECORDING SYSTEM FOR CONTINUOUS ARRHYTHMIA MONITORING IN WIRELESS TELE-HOME-CARE

The advantage of wireless technology gives new options in monitoring vital parameters of arrhythmia with wearable biomedical sensors for tele-home-care purposes. The use of telecommunications for remote diagnosis is growing rapidly, and there are several products and projects for mobile ECG recording using internet solutions, Bluetooth technology, WAP-based implementation, etc. A remote diagnosis system integrating digital telemetry has been developed, using a wireless patient module, a homecare station and a remote clinical station [23].

The concept for the new, wireless and continuous event recorder for ECG-signals is based on the construction of the new ECG sensor. The sensor includes two electrical contact points applied directly to the patient's skin with the use of sticky, conducting hydro gel, and they are directly connected to the electronic circuits to amplify the signal with the wireless transmission feature of the recordings to a receiver integrated as a component within a Hand Held Device (HHD) [24].

The HHD is the "intelligent" unit to analyze and save the recorded signals temporarily. This unit uses a standard telecommunication facility, GPRS (General Packet Radio Service), to send an alarm signal together with the measured ECG-recordings to a remote WPR Internet connected server. The doctor at the hospital uses a special remote WPR client installed on a standard PC as a Clinical Diagnostic Station (CDS) [24]. Trained personnel will thus be able to evaluate the ECG-recordings and for diagnosing the conditions detected, and follow up the patients accordingly.

The wireless sensor will continuously measure and wirelessly transmit sampled ECG-recordings by the use of a built-in RF-radio transmitter. The RF-radio receiver converts the ECG-samples with the use of a microcontroller before transmitting the ECG-samples to a standard personal digital assistant (PDA) with a RS232 connector. It uses a small plastic enclosure for the receiver with the same size as the PDA which is a Fujitsu-Siemens Pocket LOOX 700 using Microsoft Windows Mobile Software 2003 for Pocket PC. It is programmed in C# based on .net compiler for Smart Device Applications.

The PDA is equipped with a CF-slot GSM/GPRS module RTM-8000 from Audiovox, and controlled by the software the PDA will automatically connect to the

GPRS mobile network and transmit necessary data to an Internet connected server, which is shown in Figure 9 [24].

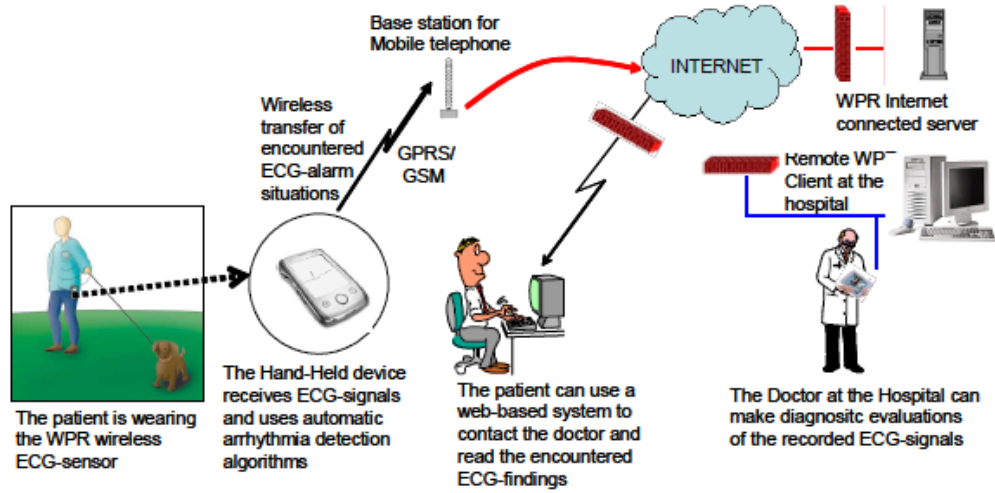
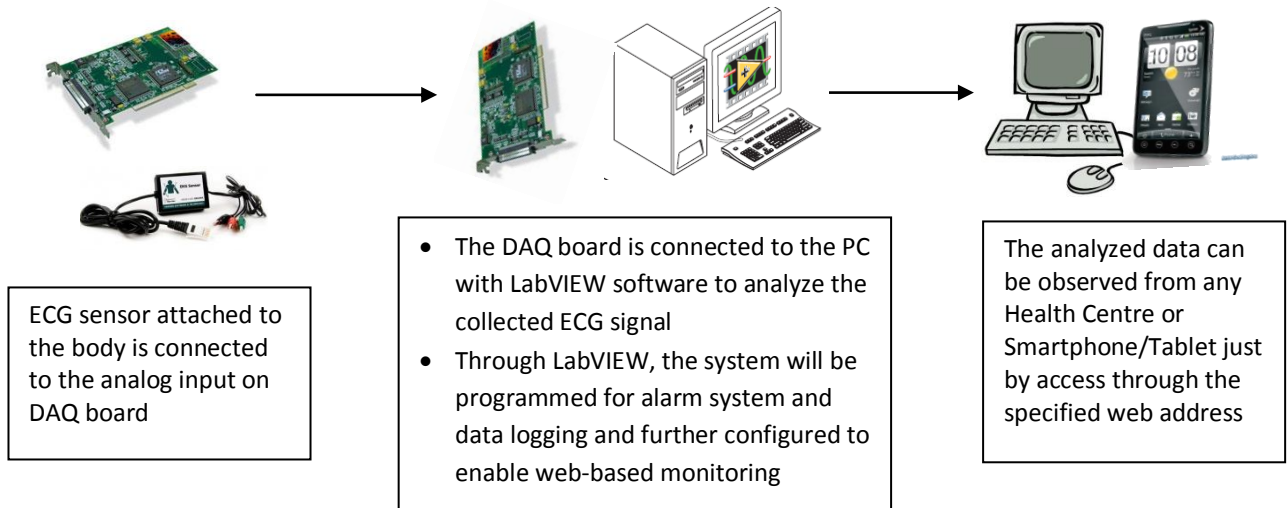

Figure 9: The illustrated diagram for the wireless tele-home-care system

CHAPTER 3

METHODOLOGY

3.1 PROJECT DIAGRAM



3.2 FLOW CHART

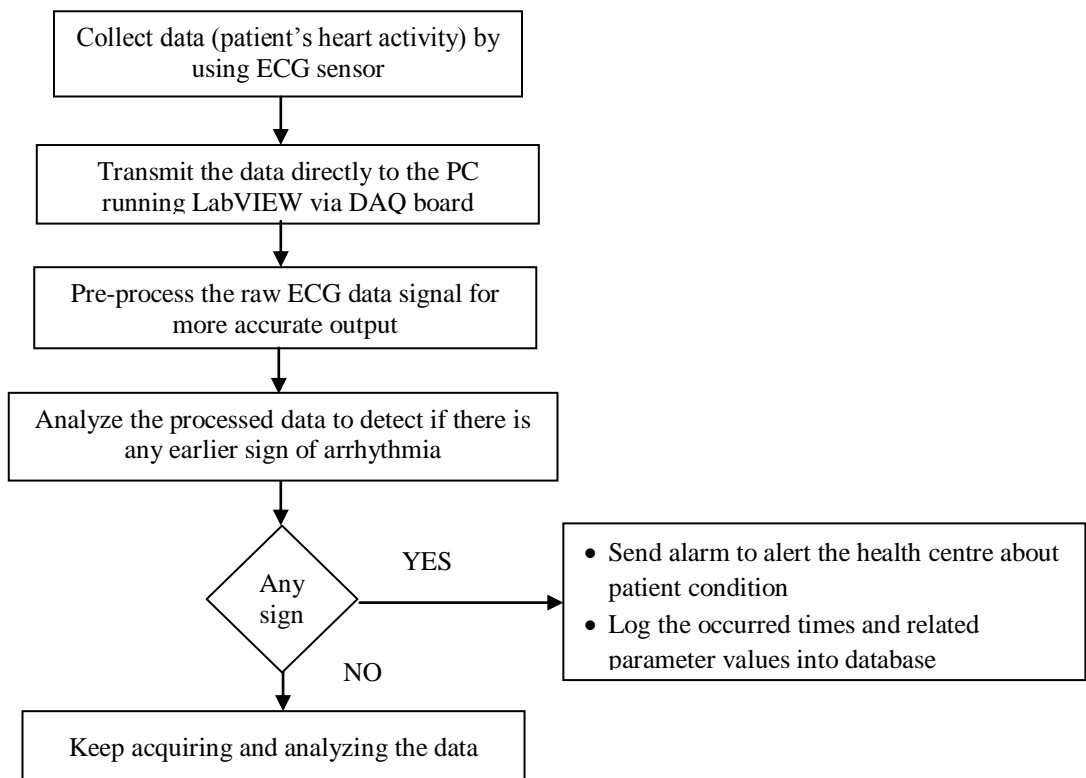

3.3 PROJECT ACTIVITIES

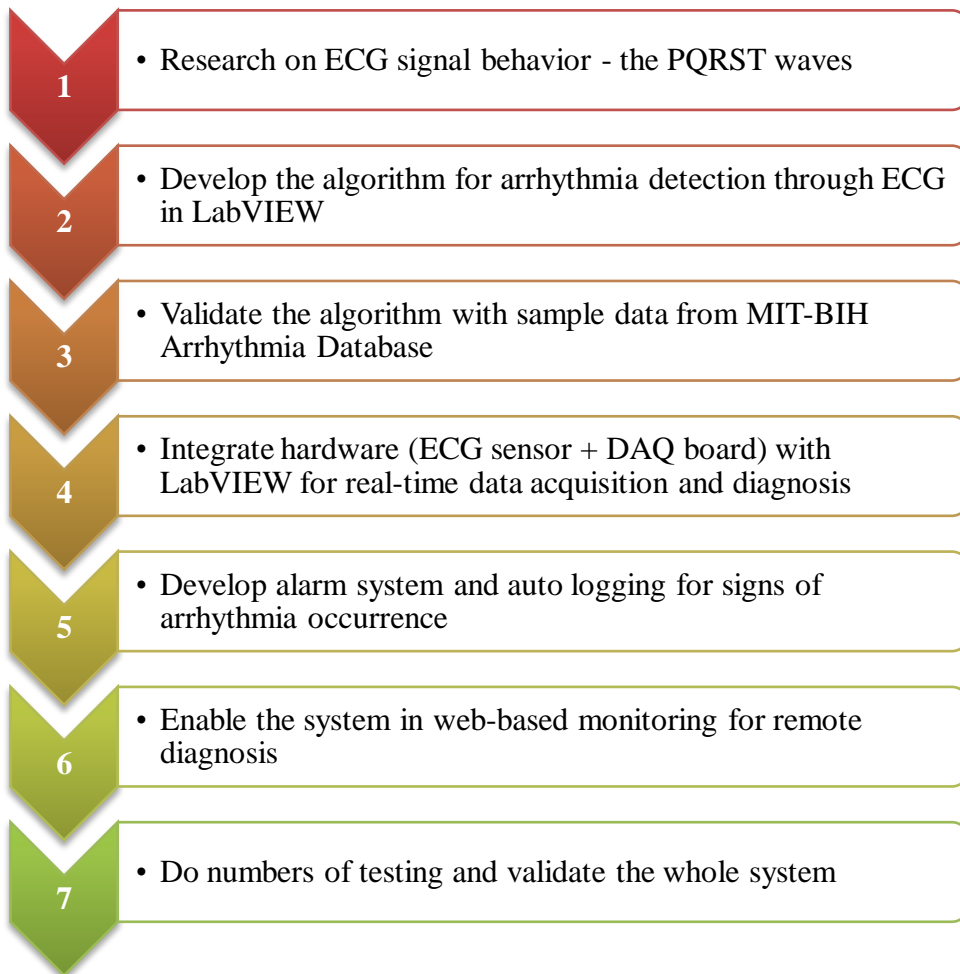

3.4 TOOLS AND EQUIPMENTS

- ECG Sensor
- DAQ board with analog I/O ports
- NI LabVIEW 2011 SP1
- NI Digital Signal Processing toolkit
- NI Web UI Builder
- Microsoft Word - report writing

3.5 GANTT CHART

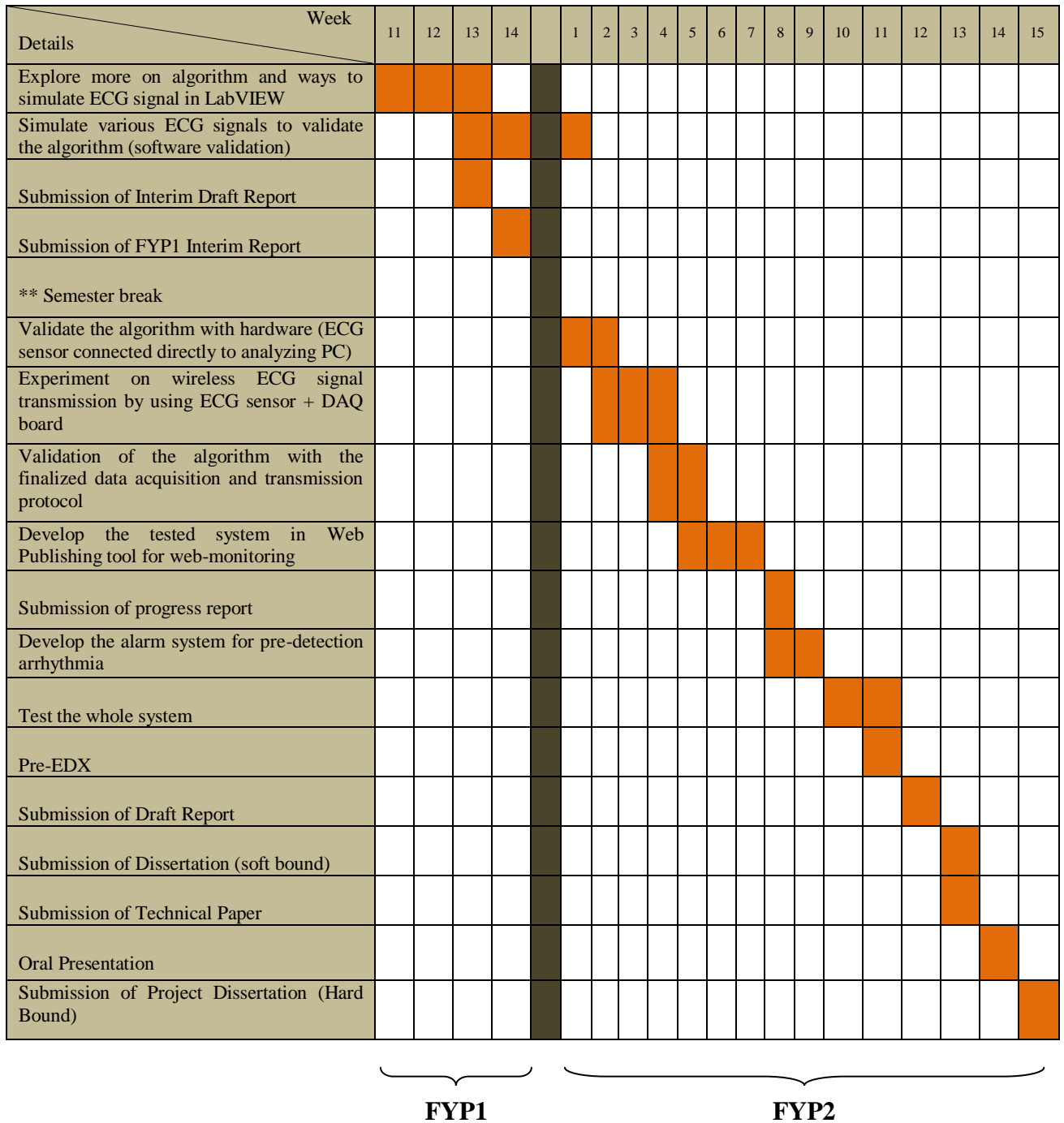

Table 1: Gantt chart

CHAPTER 4

RESULTS

4.1 Research on ECG Signal Behavior

ECG consists of a series of waveforms occurring in a repetitive order which forms by three main parts beginning with the P wave, followed by the QRS wave complex, and ending with the T wave. The P wave represents the depolarization of the atria and is associated with their contraction. The QRS wave complex consists of three waves where the first negative deflection is the Q wave and is followed by a positive deflection called the R wave. The complex ends with a negative deflection known as the S wave. The QRS wave complex denotes depolarization of the ventricles and is associated with their contraction. The last wave is called the T wave, and is usually represented by a positive deflection. The T wave indicates ventricular repolarization.

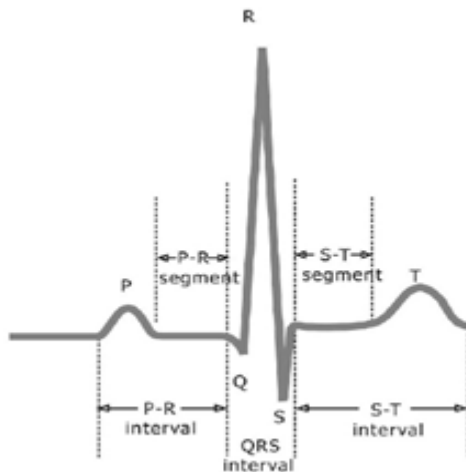

Figure 10: The P-QRS-T waves

Various types of arrhythmia are detected by analyzing the P-QRS-T waves behavior mainly by calculating the number of heart beat per minute (bradycardia or tachycardia) and observing the rhythm pattern of the ECG waveform either it is regular or irregular. Besides, certain types of arrhythmia are traced by the absence of one part of the waves as well as the interval between the waves.

For example, the absence of P wave indicates that no blood is being pumped to the heart while the super fast heart beat (about 150 bpm) and wide interval of QRS wave shows the occurrence of ventricular tachycardia which is the severe type of arrhythmia that can lead to death. Below is the range of each waveform for normal healthy adult.

| Features | Normal Value | Normal Limits |
|---------------------------|----------------|---------------|
| P width | 110 ms | ± 20 ms |
| PQ/PR interval | 160 ms | ± 40 ms |
| QRS width | 100 ms | ± 20 ms |
| QT _c interval* | 400 ms | ± 40 ms |
| RR interval | 600 to 1000 ms | ± 100 ms |
| P amplitude | 0.15mV | ± 0.05 mV |
| QRS height | 1.5mV | ± 0.5 mV |
| ST level | 0mV | ± 0.1 mV |
| T amplitude | 0.3mV | ± 0.2 mV |

Table 2: Typical lead II ECG features and their normal values for a healthy adult

4.2 ECG Pre-processing

The ECG signal needs to be pre-processed first before extracting the useful information features as the recorded ECG signal is often contaminated by noise and artifacts that can be within the frequency band of interest and manifest with similar characteristics as the ECG signal itself. Among the contaminants that can strongly affect the ECG signal analysis are the power line interference, baseline wandering and other wideband noises. The power line interference usually can be removed through the ECG signal acquisition hardware while the other contaminants are removed by signal processing approaches.

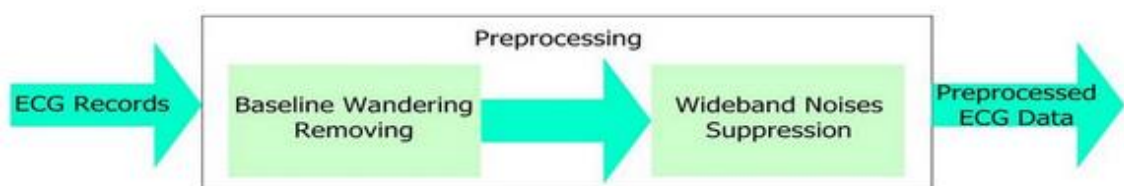

Figure11: Typical ECG signal processing flowchart

4.2.1 Baseline Wandering Removal Through Wavelet Transform Approach

The wavelet transform is an effective way to remove signals within specific subbands. The LabVIEW Advanced Signal Processing toolkit provides the Wavelet Analysis (WA) Detrend function code which can remove the low frequency trend of a signal. The result of filtered ECG signal is more stationary and explicit than the original after the removal of baseline wandering.

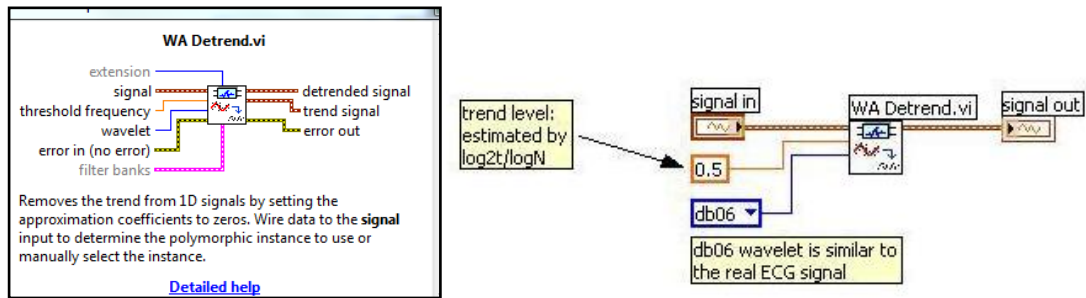

Figure 12: Using the WA Detrend function code to remove the baseline wandering

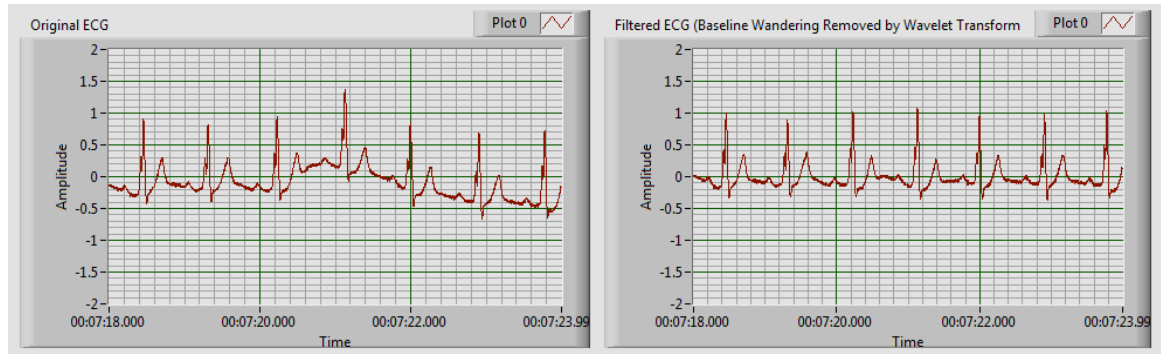

Figure 13: The baseline wandering removal result

4.2.2 Wideband Noise Suppression Through Wavelet Denoise

As some other types of noise might still affect the ECG signal features extraction, the removal of wideband noise is applied so that the output parameter values will be more accurate. This process is done by using the Wavelet Denoise Express function code through the implementation of the Undecimated Wavelet Transform (UWT) to the signal. The function code first decomposes the ECG signal into several subbands by applying the wavelet transform, followed by modification each wavelet coefficient through a

threshold function, and lastly reconstructs the denoised signal. Figure 15 shows the comparison between the suppressed wideband noise ECG signal and the original data with all details of the signal are kept invariant.

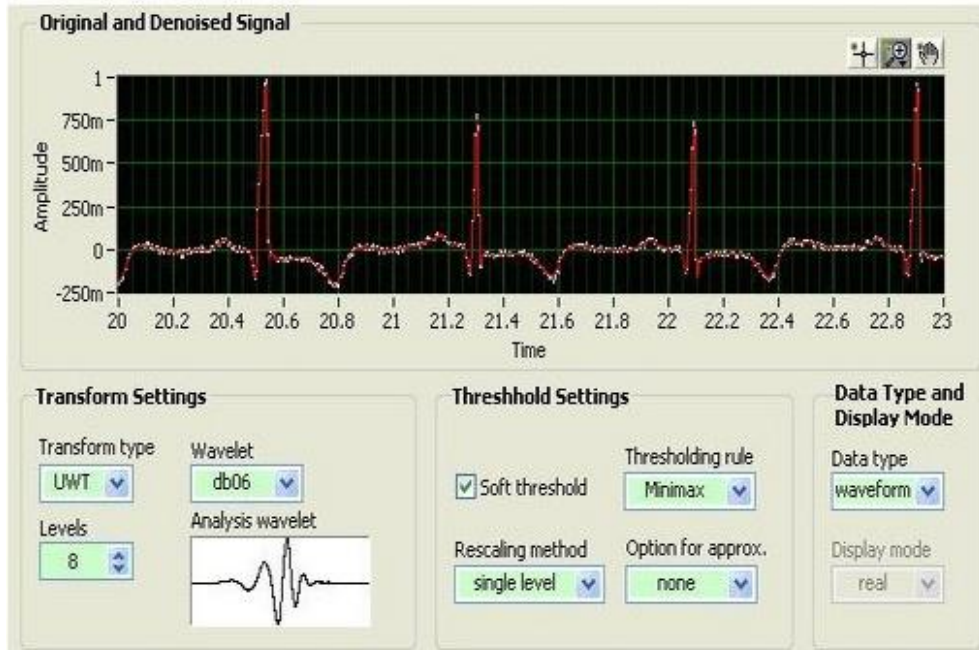

Figure 14: Wideband noise removal by applying the Undecimated Wavelet Transform (UWT)

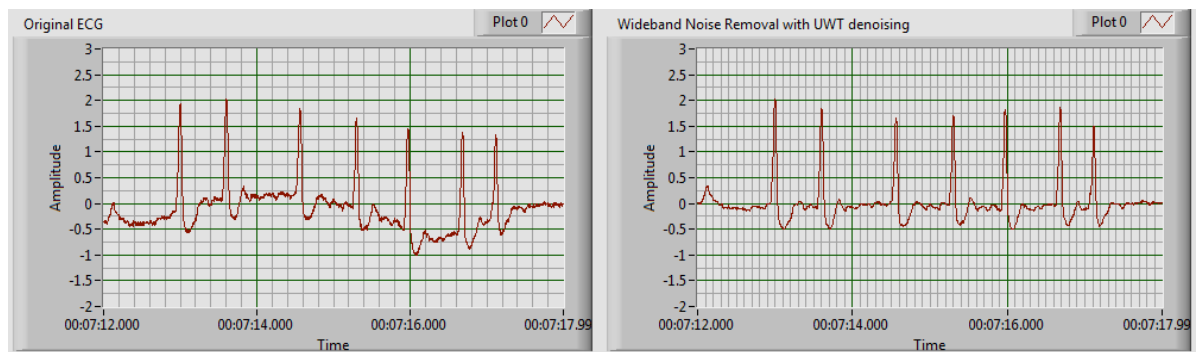

Figure 15: The result of Wideband Noise Removal using UWT denoising

4.3 Validation of Arrhythmia Detection Algorithm

Cardiologists and nurses used to describe types of arrhythmia by manually interpreting the recorded ECG graph. The ECG graph paper record is standardized to run at 25mm/sec. Each small block on the horizontal axis represents 0.04 seconds, thus the large block (consists of five small blocks) represents 0.2 seconds.

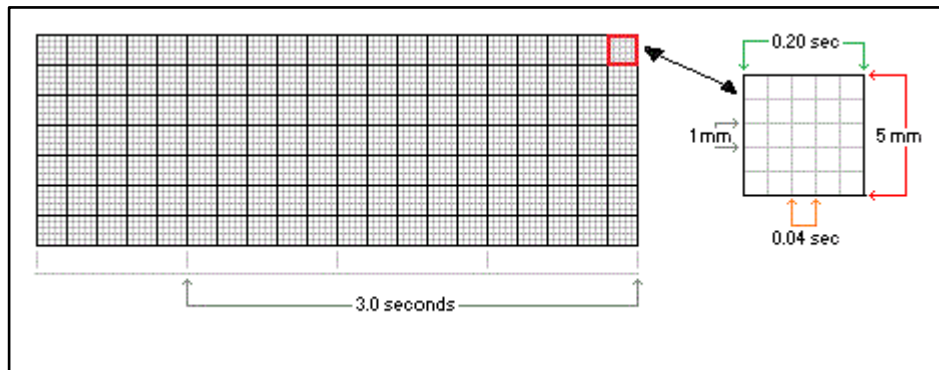

Figure 16: The ECG graph paper

In this project, the ECG graph is analyzed automatically through the ECG feature extraction function code in LabVIEW supported by NI Biomedical toolkit.

To validate the algorithm used inside the ECG feature extraction, few ECG sample data is fed into the program to see the features output and compare with the manual interpretation. The ECG sample data are obtained from MIT-BIH (Massachusetts Institute of Technology and Beth Israel Hospital) Arrhythmia Database which has been collected from various patients suffering of arrhythmia [25].

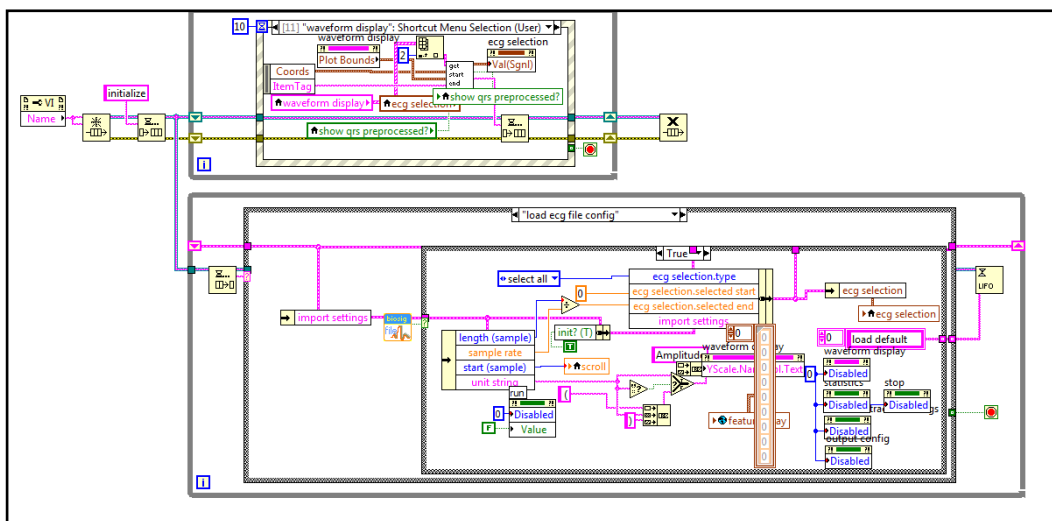
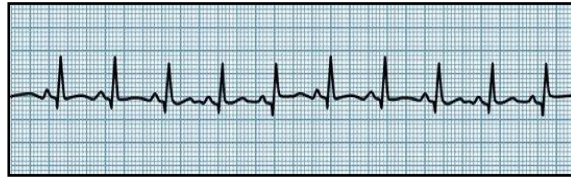

Figure 17: A glimpse of the coding behind ECG feature extraction function code

4.3.1 Calculation of heart beat per minute

The heart beat per minute can be manually estimated by taking 6 seconds strip of ECG graph and calculate the number of QRS peak within the 6 seconds. The bpm then can be obtained by multiply the number of QRS peaks (in 6 seconds) by 10 (6 secs x 10 = 60 seconds or 1 minute) [26].



The beats per minute for this 6 seconds ECG stripe is,
= number of QRS peaks x 10
= 10 x 10
= 100 bpm (tachycardia)

In LabVIEW, the number of QRS peaks is obtained from the ecg_QRS_detector function code. The rest of the code and the result are shown below.

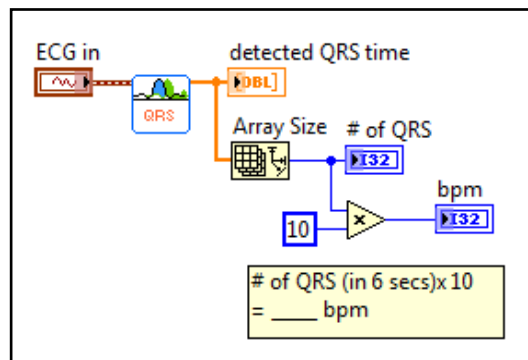

Figure 18: The code to calculate the beats per minute



Figure 19: Result of calculating beats per minute in LabVIEW

4.3.2 QRS time interval

The QRS interval is crucial in detecting severe arrhythmia such as ventricular tachycardia (VT). The occurrence of VT is shown when the QRS interval is more than 0.12s [17]. Through manual interpretation, the QRS interval is measured by calculating the small boxes governed by the QRS complex wave. The example to calculate the QRS interval is shown below.



Figure 20: Marking the 3 small boxes with Vernier caliper

Normal QRS interval for a healthy adult should be less than 0.12s. Since the small box on horizontal axis represents 40ms, thus the QRS interval should be less than 3 small boxes.

In LabVIEW, the QRS interval is calculated by subtracting the QRS onset with the QRS offset parameter (in seconds). These parameters are extracted from the built-in QRS feature extraction function code in the biomedical toolkit.

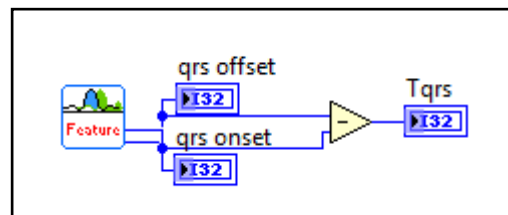

Figure 21: LabVIEW programming for QRS time interval

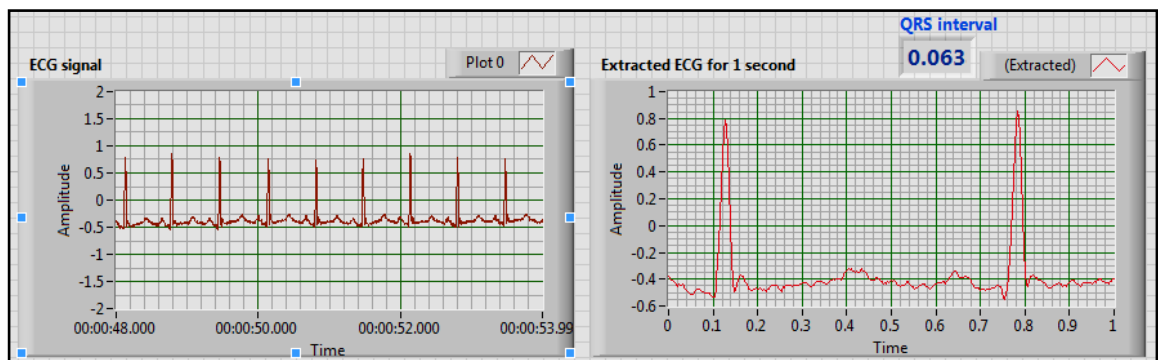

Figure 22: Result of QRS interval in LabVIEW

The accuracy of the used algorithm is summarized in the following Table 3



| ECG signal | Number of heart beat (bpm) | | | QRS time interval (s) | | |
|---|----------------------------|---------|----------|-----------------------|---------|----------|
| | Manual | LabVIEW | Accuracy | Manual | LabVIEW | Accuracy |
|  | 80 | 80 | 100% | 0.60 | 0.64 | 93.75% |
|  | 120 | 120 | 100% | 0.50 | 0.57 | 87.72% |
|  | 170 | 170 | 100% | 0.36 | 0.37 | 97.30% |

Table 3: The accuracy of algorithm used based on 6 seconds strip of ECG

4.4 Hardware Integration (ECG Sensor with DAQ board)

To allow real-time data collecting, the system is attached with ECG sensor from Vernier Instruments. The sensor is connected to the analyzing PC via analog input on DAQ board.



Figure 23: The ECG sensor from Vernier Instruments

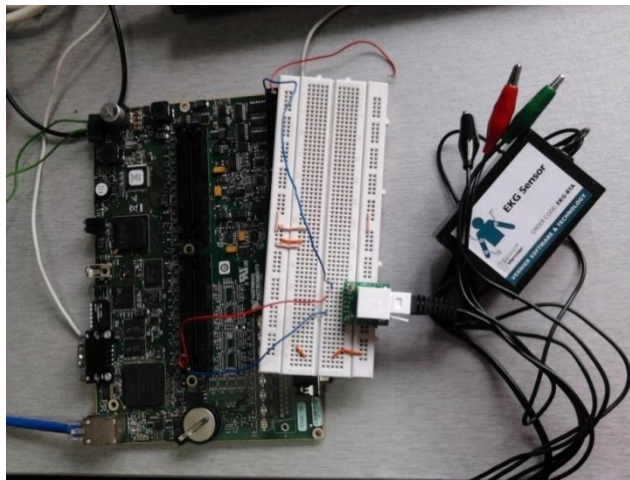

Figure 24: ECG sensor connected to the PC via DAQ board

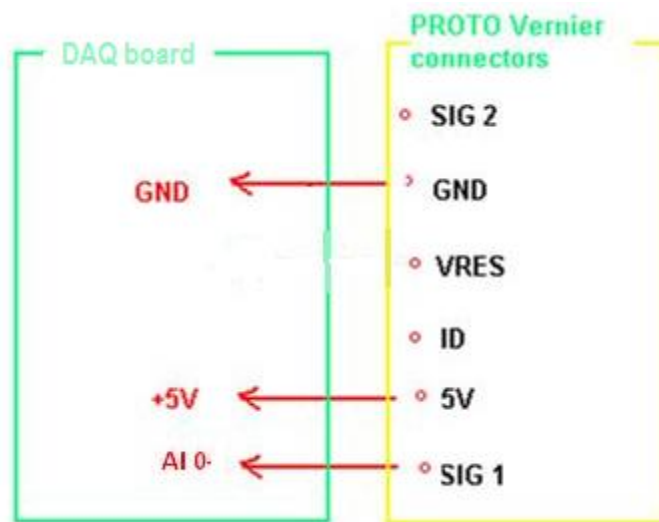

Figure 25: The connection from the PROTO Vernier connector to the DAQ board

The ECG sensor has three electrodes which act as the positive terminal, negative terminal and the reference. There are few ways of placing the ECG electrodes on the body. Figure 26 shows one example of the placement. The sensor is then programmed in LabVIEW to allow the acquisition of ECG data from patients and integrated with the rest of the developed system.

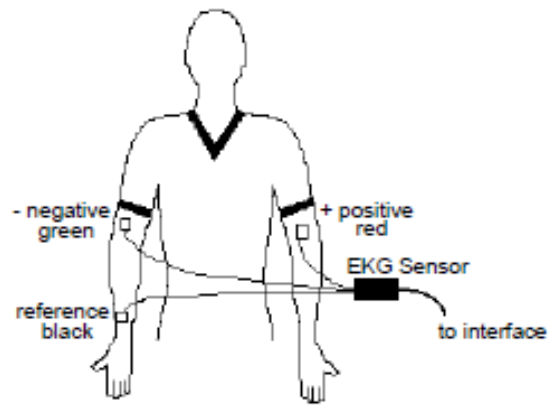

Figure 26: The placement of the ECG electrode patches on the patient

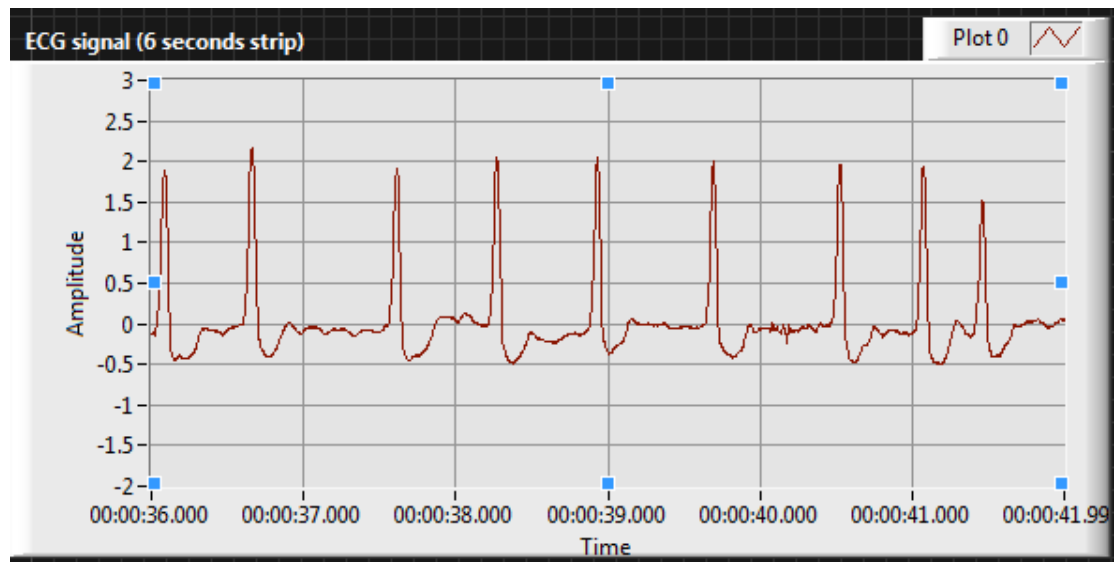

Figure 27: Acquisition of live ECG data through ECG sensor

4.5 Alarm System and Auto Data Logging

In order to alert the health center once sign of arrhythmia occurs, the alarm system is developed so that needed action can be taken earlier. The alarm system is designed to be highlighted in bright red colour on the user interface front panel once the sign happens.

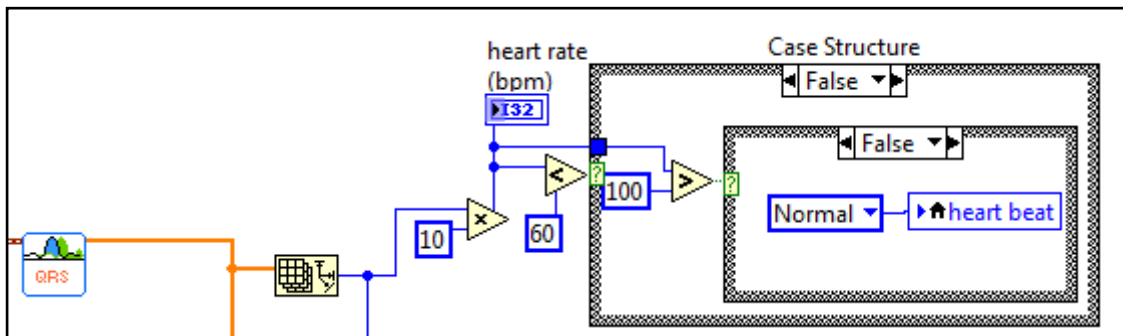

Figure 28: The algorithm for alarm system

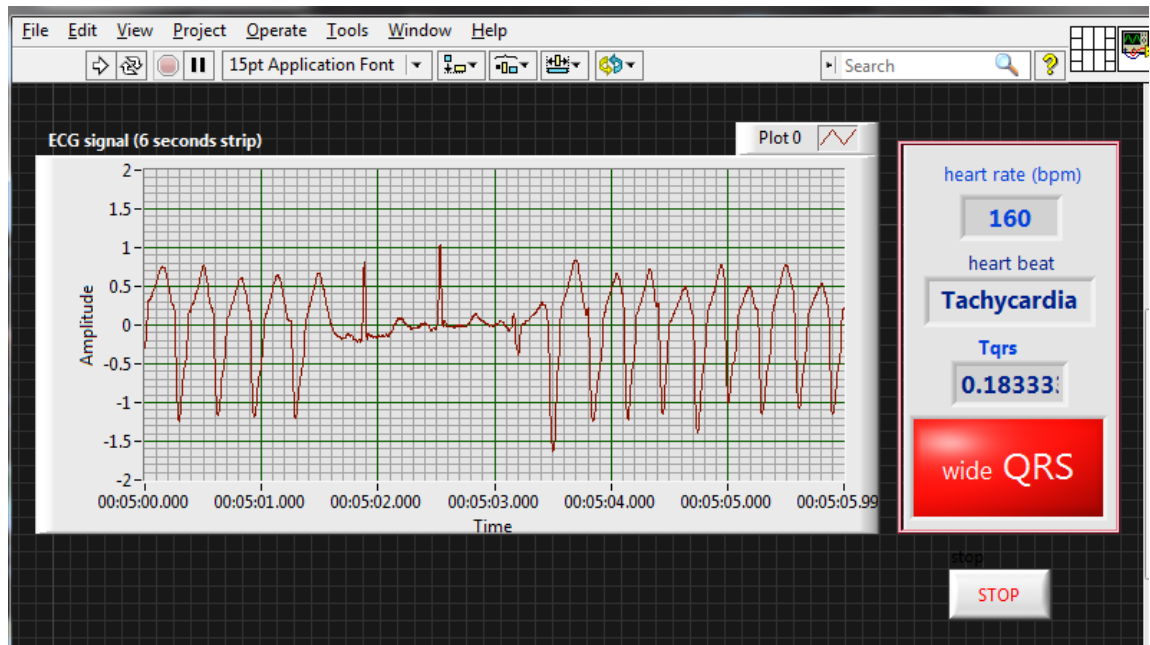

Figure 29: The GUI for alarm system

For data logging feature, the system will log the result of abnormalities of the heart beat in .tdm format. The database then can be viewed via Microsoft Excel.

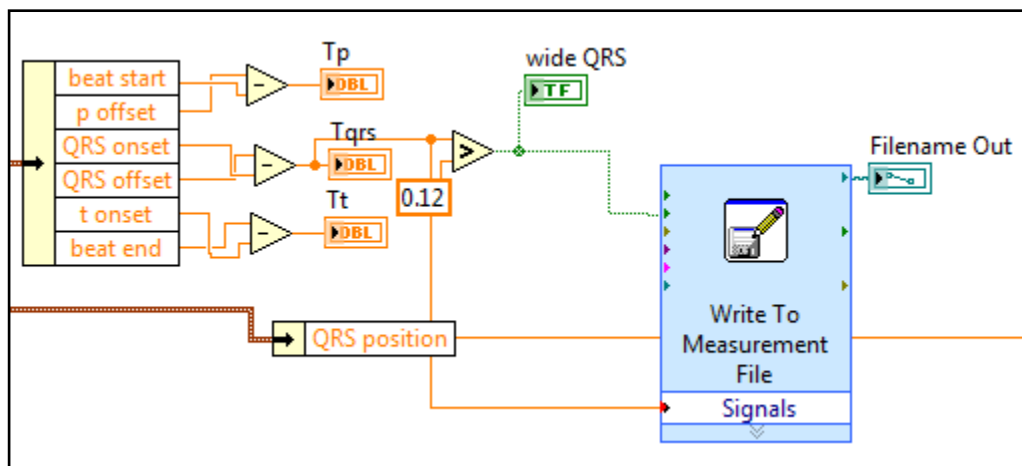

Figure 30: The function code for data logging

| D14 | | f_x |
|-----|----------------------------|---------------------|
| | A | B |
| 1 | Time | QRS interval |
| 2 | 08/13/2012 06:20:22.988 PM | 0.152777778 |
| 3 | 08/13/2012 06:20:38.288 PM | 0.155555556 |
| 4 | 08/13/2012 06:20:38.588 PM | 0.213888889 |
| 5 | 08/13/2012 06:20:38.688 PM | 0.213888889 |
| 6 | 08/13/2012 06:20:38.788 PM | 0.183333333 |
| 7 | 08/13/2012 06:20:39.837 PM | 0.213888889 |
| 8 | 08/13/2012 06:20:39.886 PM | 0.222222222 |
| 9 | 08/13/2012 06:20:39.988 PM | 0.261111111 |
| 10 | 08/13/2012 06:20:40.088 PM | 0.269444444 |
| 11 | 08/13/2012 06:20:40.188 PM | 0.302777778 |
| 12 | 08/13/2012 06:20:40.488 PM | 0.152777778 |
| 13 | 08/13/2012 06:20:40.588 PM | 0.497222222 |
| 14 | 08/13/2012 06:20:40.688 PM | 0.425 |
| 15 | 08/13/2012 06:20:40.788 PM | 0.175 |
| 16 | 08/13/2012 06:20:40.888 PM | 0.241666667 |
| 17 | 08/13/2012 06:20:40.988 PM | 0.394444444 |
| 18 | 08/13/2012 06:20:41.088 PM | 0.277777778 |
| 19 | 08/13/2012 06:20:41.188 PM | 0.261111111 |
| 20 | 08/13/2012 06:20:41.288 PM | 0.183333333 |
| 21 | 08/13/2012 06:20:41.839 PM | 0.183333333 |
| 22 | 08/13/2012 06:20:41.887 PM | 0.144444444 |
| 23 | 08/13/2012 06:20:43.488 PM | 0.172222222 |
| 24 | | |
| 25 | | |

Figure 31: The logged data of the wide QRS interval occurrence

4.6 Web-Based Monitoring Feature

LabVIEW has its own feature for web publishing application. Through this feature, the live result updated from the host PC can be monitored anywhere by just browsing to the specific URL link provided.

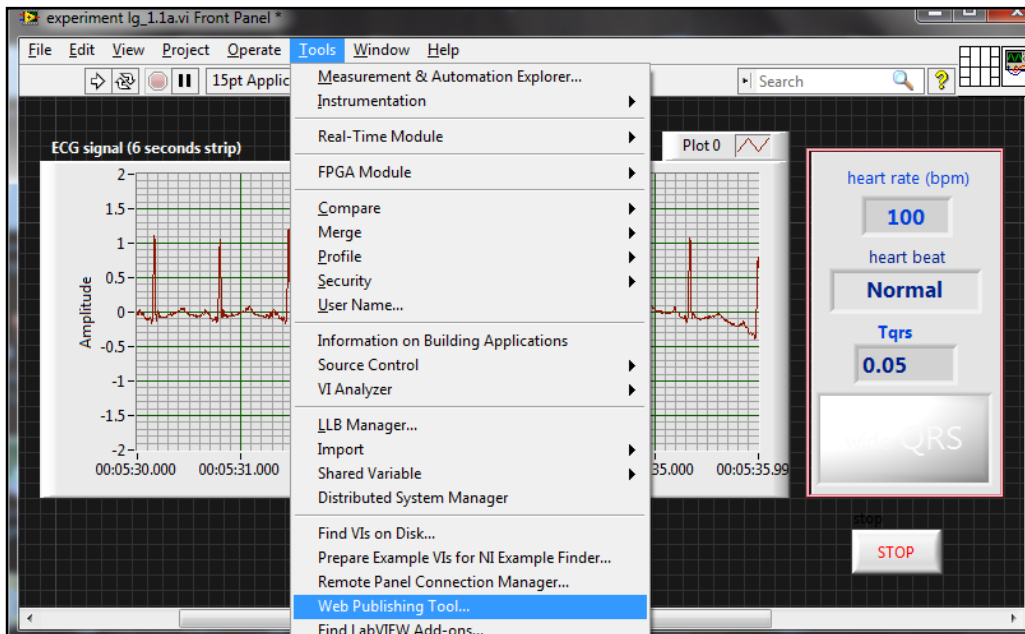

Figure 32: Access to web publishing tool application

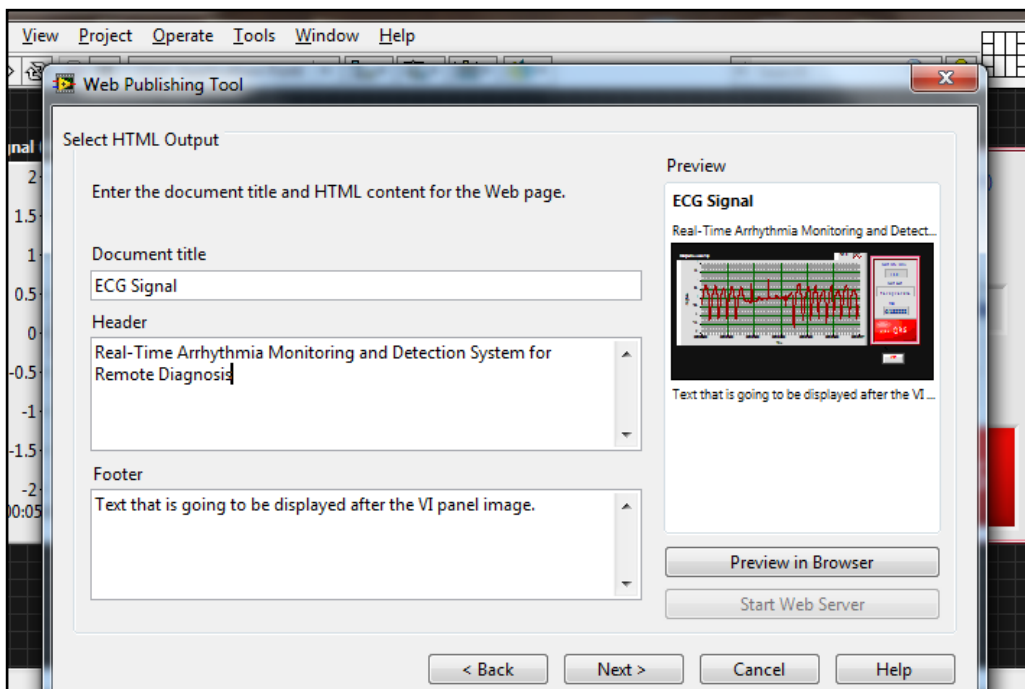

Figure 33: Web publishing setup

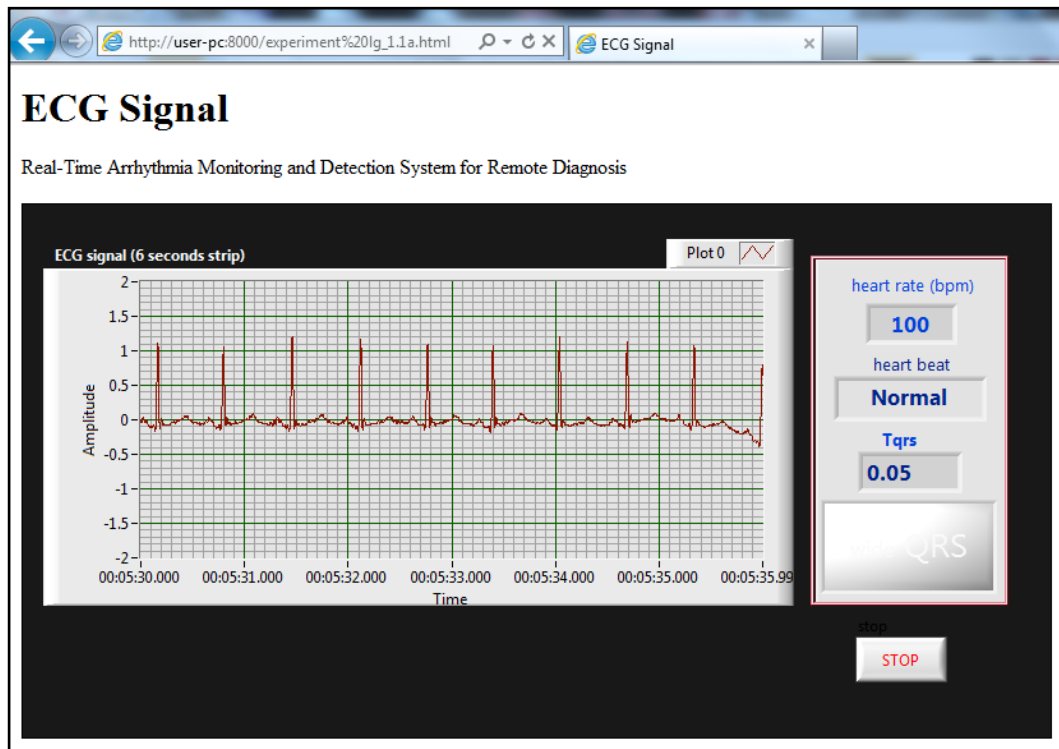

Figure 34: The GUI for the complete system launched on the specific URL link

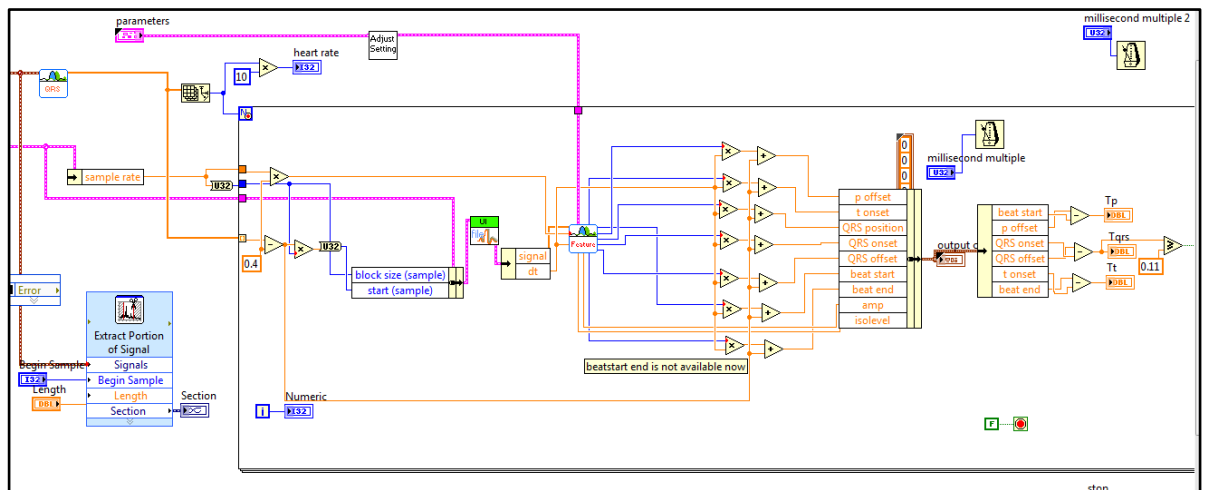

Figure 35: The LabVIEW programming for the complete system

All scope for this project is successfully implemented and works well within the proposed system. However, few aspects still can be done and improved for future betterment.

CHAPTER 5

CONCLUSION

Real time arrhythmia monitoring system is not a new thing in the health field. Due to some limitation in other approaches, many solutions has been introduced for more comfort on the patient side as well as bring the life of doctors and health experts less hectic. With the advanced of current communication technology, remote real-time monitoring and diagnosing is no longer impossible to be implemented. Despite, more researches still have to be done as the system needs more improvement for better performance.

RECOMMENDATIONS

This project is developed based on normal ECG sensor and DAQ board for data acquisition. As the technology is getting advanced beyond time, this system would be more helpful in the future by replacing the normal ECG sensor with the wireless sensor so that the patient has more freedom and feel more comforted to move.

Besides, this system mainly focuses on the detection of the severe arrhythmia which is the ventricular tachycardia. It will be more assistive if this project can be further evolved to detect all types of arrhythmia such as the atrial fibrillation, atrial flutter, the premature ventricular contraction and etc.

REFERENCES

1. <http://www.medterms.com/script/main/art.asp?articlekey=232>
2. <http://www.medicalnewstoday.com/articles/8887.php>
3. World Health Organization, "The premise program: Prevention of Recurrences of Myocardial Infarction and Stroke Study", WHO.
4. <http://www.mayoclinic.com/health/heart-arrhythmias/DS00290/DSECTION=tests-and-diagnosis>
5. Gottipaty VK, Khoury L, Beard JT, Hamson V. A novel real-time ambulatory cardiac monitoring system is user-friendly and effective for identifying cardiac arrhythmias: clinical studies [abstract]. Columbia, SC: Biowatch Medical, Inc;2008.
6. Joshi AK, Kowey PR, Prystowsky EN, Benditt DG, Cannon DS, Pratt CM, McNamara A, Sangrigoli RM. First experience with a Mobile Cardiac Outpatient Telemetry (MCOT) system for the diagnosis and management of cardiac arrhythmia. *Am J Cardiol.* 2005;95:878–881.
7. Tavakoli, V.; Sahba, N.; Hajebi, N.; "A fast and accurate method for arrhythmia detection," *Engineering in Medicine and Biology Society, 2009. EMBC 2009. Annual International Conference of the IEEE* , vol., no., pp.1897-1900, 3-6 Sept. 2009
8. M.S. Nambakhsh, Vahid Tavakoli, Nima Sahba, "FPGA-Core Defibrillator using Wavelet-Fuzzy ECG Arrhythmia Classification", 30th Annual International IEEE EMBS Conference, Vancouver, Canada, 20-25 Aug. 2008, pp. 2673 – 2676
9. S. Karimifard, A. Ahmadian, "Morphological Heart Arrhythmia Detection Using Hermitian Basis Function and KNN Classifier," In Proceedings of EMBS, 2006.
10. Ahmadian, S. Karimifard, " Morphological Heart Arrhythmia Classification Using Hermitian Model of Higher-Order statistic," In Proceedings of EMBS, 2007; In press.
11. Ahmadian, S. Karimifard, " An Efficient Piecewise Modeling Of ECG Signals Based On Hermitian Basis Functions," In Proceedings of EMBS, 2007, In press.
12. V. X. Afono and W. J. Becker, "Detecting ventricular fibrillation, "Selecting the appropriate time frequency analysis tool for the application" *Inst. Elect. Eng.*, pp. 152–159, 1995.
13. R. Fernandez, J. Folgueras, and O. Colorado, "Validation of a Set of Algorithms for Ventricular Fibrillation Detection: Experimental Results," 25th Annual International Conference of the IEEE. Sept. 2003, vol.3, pp 2885-2888.
14. J. C. T. B. Moraes, M. Blechner, F. N. Vilani, and E. V. Costa, " A Real Time QRS Complex Classification Method using Mahalanobis Distance," *Computers in Cardiology*, Sept. 2002, pp. 213-216.
15. H. Huang, H. B. Xie and Z. Z. Wang, "Discrimination of VF and VT with Method of Detrended Fluctuation Analysis," *International Conference on Intelligent Mechatronics and automation Chengdu*, Aug. 2004, pp. 881-884.
16. K. Minami, H. Nakajima, and T. Toyoshima, "Real-Time Discrimination of Ventricular Tachyarrhythmia with Fourier- Transform Neural Network," *IEEE Trans. on Biomedical Engineering*, vol.46, 1999, pp. 176-185, .
17. J. L. Rojo-Alvarez, A. Arenal-Maiz, A. Artes- Rodriguez, "Discriminating between Supraventricular and Ventricular Tachycardias from EGM Onset Analysis," *IEEE Engineering in Medicine and Biology Magazine*, vol.21, Issue 1, Jan.-Feb. 2002, pp. 16-26.

18. Amann, R. Tratnig, and K. Unterkofler, "Detecting Ventricular Fibrillation by Time-Delay Methods," *IEEE Trans. on Biomedical Engineering*, vol.54, 2007, pp174 -177.
19. Creighton University Ventricular Tachyarrhythmia Database.
<http://physionet.org/physiobank/database/cudb/>
20. Z. X. Zhang, S. H. Lee, and J. S. Lim, "Comparison of Feature Selection Methods in ECG Signal Classification," *The 4th International Conference on Ubiquitous Information Management and Communication (ICUIMC 2010)*, Jan.2010, pp. 502-506.
21. J. S. Lim, "Finding Features for Real-Time Premature Ventricular Contraction Detection Using a Fuzzy Neural Network System," *IEEE TRANSACTIONS ON NEURAL NETWORKS*, vol. 20, Mar. 2009, pp. 522-527.
22. Zhen-Xing Zhang; Xue-Wei Tian; Lim, J.S.; , "Real-time algorithm for a mobile cardiac monitoring system to detect life-threatening arrhythmias," *Computer and Automation Engineering (ICCAE), 2010 The 2nd International Conference on* , vol.4, no., pp.232-236, 26-28 Feb. 2010
23. Y. H. Nam, Z. Halm, Y. J. Chee, and K. S. Park, "Development of remote diagnosis system integrating digital telemetry for medicine," presented at *Proceedings of the 20th Annual International Conference of the IEEE Engineering in Medicine and Biology Society*, 1998.
24. Fensli, R.; Gunnarson, E.; Gundersen, T.; , "A wearable ECG-recording system for continuous arrhythmia monitoring in a wireless tele-home-care situation," *Computer-Based Medical Systems, 2005. Proceedings. 18th IEEE Symposium on* , vol., no., pp. 407- 412, 23-24 June 2005.
25. <http://physionet.org/physiobank/database/mitdb/>
26. http://www.youtube.com/watch?v=ex1k_MPF-w4