

**Spray Characteristic by using Phase Doppler Anemometry (PDA) and Laser
Doppler Anemometry (LDV)**

by

Mohd Akmal Bin Mohd Sobli

Dissertation submitted in partial fulfillment of the requirements for the
Bachelor of Engineering (Hons.)
(Mechanical Engineering)

JULY 2008

Universiti Teknologi PETRONAS

Bandar Seri Iskandar

31750 Tronoh

Perak Darul Ridzuan

CERTIFICATION OF APPROVAL

**Spray Characteristic by using Phase Doppler Anemometry (PDA) and Laser
Doppler Anemometry (LDV)**

by

Mohd Akmal Bin Mohd Sobli

A project dissertation submitted to the
Mechanical Engineering Programme
Universiti Teknologi PETRONAS
in partial fulfillment of the requirement for the
BACHELOR OF ENGINEERING (Hons)
(MECHANICAL ENGINEERING)

Approved by,

(Dr. Ir. Masri Baharom)

UNIVERSITI TEKNOLOGI PETRONAS
TRONOH, PERAK
July 2008

CERTIFICATION OF ORIGINALITY

This is to certify that I am responsible for the work submitted in this project, that the original work is my own except as specified in the references and acknowledgement, and that the original work contained herein have not been undertaken or done by unspecified sources or persons.

MOHD AKMAL BIN MOHD SOBLI

ACKNOWLEDGEMENT

Thanks to merciful Allah S.W.T for His blessing giving me a chance to finish my Final Year Project (FYP), also thanks to all who gave me support, encouragements, concerns, and helps along during my entire project. First of all to my loving parents, Mohd Sobli B Ismail and Radiah Bt Latiff for their never ending love, concern, support, motivation and care to ensure performing the best for my FYP. Besides, a sincere thanks to the project supervisor, Dr. Abdul Rashid Abdul Aziz for the guidance, knowledge, information and ideas that helped me to carry out projects that were assigned for one year. I would also like to express appreciation to UTP staff who met during lab activities especially to Mr. Jani, Mr. Khairul Anuar, Mr. Firmanshah and Mr. Faisal from UTP Mechanical Engineering Laboratories for assisting me throughout my FYP. Not forgotten to my colleagues Mr. Nazrin Zaini who was so much friendly, helpful, supportive and cooperative during my entire Final Year Project. Last but not least, I would like to express gratitude Mechanical Engineering Department of Universiti Teknologi Petronas (UTP) for providing this chance to undertake this remarkable final year research project. This course has good coverage on the mechanical engineering programmed whereby the students can actually contribute their effort and knowledge towards achieving a common goal.

ABSTRACT

A method and analysis was developed to quantify the amplitude of deterministic spray unsteadiness based on Phase Doppler Anemometry (PDA) or Laser Doppler Velocimetry (LDV). It is a technique for measuring the direction and speed of fluids and air. In the simplest form, the beam crosses two beams of collimated, monochromatic and coherent laser light in the flow of the fluid being measured. The main objective of this project is to study the existing of the on line size, velocity and concentration of droplets or bubbles suspended in bio ethanol and gasoline mixture. In this study, the test chamber has been fabricated to provide an optical access for laser penetration during spray injection process. The injection rate and patterns, which are dependent on the different proportion of bio ethanol E10, E85 and pure gasoline determine the atomization process. Furthermore, spray cone angle and penetration length was studied and analyzed for each substances utilization. The result shows the velocities distribution and sizes for every point of the spray patterns. The flow patterns varied for each substances that used during the engine testing. The results interpretation achieve can definitely outcome the best theory for the whole project based on comparison each of the test mixture samples. In conclusion, the aims of the study have been fulfilled. Finally, several recommendations have been made to improve the relevant study and future works.

TABLE OF CONTENTS

CERTIFICATION OF APPROVAL	I
CERTIFICATION OF ORIGINALITY	II
ABSTRACT	III
ACKNOWLEDGEMENT	IV
CHAPTER 1 : INTRODUCTION	1
1.1 Background of Study	1
1.2 Problem Statement	2
1.3 Significance of Study	3
1.4 Objectives	3
1.5 Scope of Study	4
1.5.1 Equipment	4
1.5.2 Experiment	4
1.6 Feasibility of The Study Timeframe	5
CHAPTER 2 : LITERATURE REVIEW	8
2.1 What is Bio-Ethanol	8
2.2 The benefits of Bio Ethanol	9
2.3 Determination of Cone and Dispersion Angles	10
2.3.1 Spray Cone Angle	10
2.3.2 Dispersion Cone Angle	11
2.4 Breakup Hollow Cone Spray	13

2.5	Pressure Atomizer	15
2.6	Twin-fluid Atomizer	15
2.7	Imaging Spray Injection near Nozzle Region	17
CHAPTER 3 : METHODOLOGY		20
3.1	Research Methodology	20
3.2	Project Progress Activity	21
3.3	Pre-Experimental	22
	3.3.1 Design and Fabrication	22
3.4	Experimental Procedures	22
	3.4.1 Laser Doppler Velocimetry Principle	23
	3.4.2 Phase Doppler Anemometry	23
	3.4.3 Laser Transmission	25
	3.4.4 Beam Focusing Point	25
	3.4.5 Final Arrangement, Alignment and Calibration	26
	3.4.6 Data Processing	27
3.5	Sample Test	28
3.6	Gantt Chart for whole Project	29
3.7	Key Milestone	30
CHAPTER 4 : RESULT AND DISCUSSION		31
4.1	Findings and Analysis	31
4.2	Velocity Distribution	33
	4.2.1 Gasoline	33
	4.2.2 Ethanol-gasoline blend 85% (E85)	37
	4.2.3 Ethanol-gasoline blend 10% (E10)	39
4.3	Discussion	41
	4.3.1 Spray Formation	41
	4.3.2 Spray Evaporation	41

4.3.3	Spray Cone Angle	42
CHAPTER 5 : CONCLUSION AND RECOMMENDATIONS		45
5.1	Conclusion	45
5.2	Recommendations	46
REFERENCES		47
APPENDICES		49

LIST OF FIGURES

Figure 2.1	Recycle Process of using Ethanol
Figure 2.1	Determination of Spray Cone Angle
Figure 2.3	Water
Figure 2.4	Ethanol + Water
Figure 2.5	Glycerol + Water
Figure 2.6	Clay + Water
Figure 2.7	Side view
Figure 2.8	Front view
Figure 2.9	Air atomizer at an air flow rate 0.111/s
Figure 2.10	Air atomizer at an air flow rate 0.181/s
Figure 2.11	Single Shot Images of the Pre-Swirl Spray and Spray Cone
Figure 2.12	Pre-Swirl Spray
Figure 2.13	Spray Cone Start to Develop
Figure 2.14	Spray Cone Relaxes
Figure 2.15	Maximum Velocity in Spray Cone
Figure 2.16	Spray Cone Collapse
Figure 2.17	Spray Detaches from the Nozzle
Figure 2.18	
Figure 3.1	Laser Doppler Velocimetry
Figure 3.2	Phase Doppler Anemometry
Figure 3.3	Beam Focusing Point

Figure 4.1	Gasoline
Figure 4.2	Ethanol-gasoline blend (E10)
Figure 4.3	Ethanol-gasoline blend (E85)
Figure 4.4	Middle Point of Gasoline Spray

LIST OF TABLES

Table 1.1	Study Job Summary (Semester 1)
Table 1.2	Study Job Summary (Semester 2)
Table 3.1	PDA Parameter Setting
Table 4.1	E85 Critical Point Measurement
Table 4.2	E10 Critical Point Measurement

CHAPTER 1

INTRODUCTION

1.1 Background of Study

Sprays are used in countless applications, both in industrial processes and commercial products. The task is optimization of fuel injection by using the mixture of the bio ethanol and gasoline as a new input approached. The investigation and optimization of spray injection is attracting interest for several reasons, among which environmental and quality aspects are the most important. Minimizing the quantity of "over-spray" is one of the key issues. Phase Doppler anemometry (PDA) or Laser Doppler Velocimetry (LDV) with its ability to measure the size and velocity of droplets simultaneously, even in highly concentrated particle systems, is expected to be a powerful tool for this research task [1].

Bio ethanol is a liquid bio fuel which is same as bio diesel. It is made from starch plants like corn, wheat and cassava, sugar plants beet and cane and sometimes cellulose plants (trees). It is produced first by fermentation, followed by distillation and finally dehydration. Bio ethanol or ethyl alcohol (C_2H_5OH) is a clear colorless liquid, it is biodegradable, low in toxicity and causes little environmental pollution. Bio ethanol burns to produce carbon dioxide and water. Bio ethanol is a high octane fuel and has replaced lead as an octane enhancer in petrol. The process of blending ethanol with gasoline can also oxygenate the fuel mixture so it burns more completely and reduces polluting emissions [2].

Bio ethanol can be used as a fuel in a number of different ways such as a blend which is ranging between 5% and 85%. For E5 or 5% blend, it can be used in all petrol engines. However, higher E85 or 85% blends require some modifications.

The most common blend is 10% ethanol and 90% petrol (E10). Vehicle engines also require no modifications to run on E10 and vehicle warranties are unaffected. Only flexible fuel vehicles can run on up to 85% ethanol and 15% petrol blends (E85). The E85 and E10 test mixture samples have been used to compare with the conventional gasoline during the project [3].

Experimental study of the flow mechanisms involved by using this substances are more important to improve engine performance, and modification needed for future engine instead of fully used gasoline. The study is partial fulfillment of the requirement for Bachelor of Engineering (Hons), Mechanical Engineering.

1.2 Problem Statement

Most of the automotive industry used conventional gasoline engine for market demand. There is no modified engine that can run the other input instead of gasoline. The bio ethanol utilization is needed as a new alternative energy since the source of petroleum will depleted for 30 till 50 years later [4].

The performance of new modification engine strongly depends on the study of using the ethanol blends as an input in direct injection process. However, the measurement of spray flow patterns each of the substance is extremely difficult. In order to increase the performance of the bio ethanol utilization, it is required to understand the flow patterns behaviour during the injection process. An experimental investigation will be carried out to measure the velocity distribution and size droplets at each point aimed in the flow patterns.

The experiment will take advantage of the availability of a non-intrusive visualizations tool in Universiti Teknologi Petronas (UTP), Phase Doppler Anemometry. It will be used to determine the horizontal and vertical velocity in every single point of the flow patterns. For that reason, a few modifications to the existing equipment need to be planned and prepared for the experimental set-up.

1.3 Significance of Study

The study of flow patterns of different samples material will be the main essence to improve performance and modification on the future engine. Flow distribution can be studied from the various parameters such as velocities distribution, size of the droplets, spray angle, spray tip penetration length and the injection rate. All the parameters are important to determine the flow patterns for each material that being used. This study was done concurrently with 2 other studies, measurement of spray characteristics by using PDA and LDV and visualization of spray injection by using High Speed Camera.

1.4 Objective

Upon completing the project, a few objectives need to be achieved. The main objectives of this project are as follows:-

- To study the existing of the on line size, velocity distribution of droplets or bubbles suspended in liquids flow especially in bio ethanol (E10 and E85)
- To measure the direction angle and tip penetration length of ethanol-gasoline blends during injection process.

1.5 Scope of Study

Scope of work would be ranging from the tools and equipment that will be used. It must be identified and familiarized prior to the laboratory tests to avoid malfunctioning of the system.

1.5.1 Equipment

Despite some advantages in using PDA and LDV, there are some difficulties need to be overcome when applying the PDA system to the direct injection process. Firstly, an optical access window or test chamber need to be designed to allow laser beam penetration to measure the velocity of the in-test chamber flow. The material used for optical access window is PolyMethyl Methacrylate or in short PMMA or Perspex. Worth noting here, the justification of using PMMA is simply because it is easy to machine.

Additionally, PDA is restricted to some parameters such as focal beam length and beam spacing. The test chamber need to be fitted towards the alignment provided during the engine running. It is to avoid the spray injection from scattering the droplets outside range to the intersection of the laser beam penetration. Therefore, comprehensive training on the PDA's software, alignment, traverse system, mode of transmission i.e backscatter mode need to be followed before commencing with real experiment.

1.5.2 Experiment

The experiment data obtained will perform in term of velocities distribution. Since PDA system used measures only one vector component of velocity at a time, substantial data is needed. Then the data is plotted to define the flow patterns thus interpret the direct injection process flow. The strategy on using the PDA systems to the injection needed

to be planned. The velocity measurements will be difficult due to the strong scattering of the droplets by the injector. Careful alignment is essential or else the data obtained is nonsense.

1.6 Feasibility of The Study Within Timeframe

The duration of this study is approximately 28 weeks or two semesters. The first semester, approximately 14 weeks are focus on designing and fabrication phase. Beside that, the training using the visualization tools also will be held in the first semester. The experimental configuration, investigation and analysis will be started at second semester or in other words, as soon as possible after the end of first phase of the study.

However, due to queuing in using the test bed and difficulty occurred for power transmission during commissioning or the pre-test configurations the study is delayed for some weeks.

Refer **Table 1.1** and **Table 1.2** for the study summary and timeframe of the study.

Table1.2: Study Job Summary (Semester 2)

No	Details	Week														
		1	2	3	4	5	6	7	8	9	10	11	12	13	14	
1	Project work continue	█	█	█							MID SEMESTER BREAK					
	Test chamber fabrication	█	█	█												
2	Submission of Progress Report I				█											
3	Project work continue				█	█	█	█								
	Engine testing				█	█	█	█								
	Prototype test running				█	█	█	█								
5	Submission of Preliminary Report II								█							
6	Discussion on PDA and LDV settings						█	█								
7	PDA lab testing							█	█	█						
8	Seminar (compulsory)									█						
9	E10,E85, gasoline testing								█	█			█			
10	Result interpretation								█	█			█	█		
11	Poster/Exhibition													█		
12	Submission of dissertation															█
13	Oral presentation														█	
14	Submission of project dissertation														█	

CHAPTER 2

LITERATURE REVIEW

2.1 What is Bio Ethanol ?

Bio ethanol is a liquid bio fuel which is same as bio diesel. It is made from starch plants like corn, wheat and cassava, sugar plants beet and cane and sometimes cellulose plants (trees). It is produced first by fermentation, followed by distillation and finally dehydration. Bio ethanol or ethyl alcohol (C_2H_5OH) is a clear colorless liquid, it is biodegradable, low in toxicity and causes little environmental pollution if spilt. Ethanol burns to produce carbon dioxide and water. Bio ethanol is a high octane fuel and has replaced lead as an octane enhancer in petrol. The process of blending ethanol with gasoline can also oxygenate the fuel mixture so it burns more completely and reduces polluting emissions.

Bio ethanol can be used as a fuel in a number of different ways such as a blend which is ranging between 5% and 85%. For E5 or 5% blend, it can be used in all petrol engines. However, higher E85 or 85% blends require some modifications. Beside that, the material functioned as a direct substitute for petrol in cars with appropriately modified engines.

The most common blend is 10% ethanol and 90% petrol (E10). Vehicle engines also require no modifications to run on E10 and vehicle warranties are unaffected. Only flexible fuel vehicles can run on up to 85% ethanol and 15% petrol blends (E85).

2.2 The Benefits of Bio Ethanol

Bio ethanol has a number of advantages over conventional fuels. It comes from a renewable resource such as crops and not from a finite resource and the crops it derives from can grow well in the European country like cereals, sugar beet and maize. Bio ethanol is also biodegradable and far less toxic than fossil fuels. Another benefit over fossil fuels is the greenhouse gas emissions. The road transport network accounts for all greenhouse gas emissions and through the use of bio ethanol, some of these emissions will be reduced as the fuel crops absorb the CO₂ they emit through growing. In addition, by using bio ethanol in older engines can help reduce the amount of carbon monoxide produced by the vehicle thus improving air quality [5].

Another advantage of bio ethanol which it can be easily integrated into the existing road transport fuel system. Bio ethanol is produced using familiar methods, such as fermentation, and it can be distributed using the same petrol forecourts and transportation systems as before. "It is generally accepted that on a well to wheel basis, bio ethanol gives a 70% carbon dioxide reduction versus petrol. This means that a 5% blend produces 3.5% less carbon emissions, whilst an 85% blend (like E85) would achieve a 50% reduction"[6].

Using ethanol means that we use a little bit less gasoline (a nonrenewable fuel). Unlike gasoline, ethanol is nontoxic (safe to handle) and biodegradable, it quickly breaks down into harmless substances if spilled. When small amounts of ethanol are added to gasoline, there are many advantages. Ethanol reduces carbon monoxide and other toxic pollution from the tailpipes of vehicles, making the air cleaner. It keeps engines running smoothly without the need for lead or other chemical additives. Because ethanol is made from crops that absorb carbon dioxide and give off oxygen, it helps reduce greenhouse gas emissions. This carbon cycle maintains the balance of carbon dioxide in the atmosphere when using ethanol as a fuel.

The process for carbon cycle configured as in Figure 2.1 below.

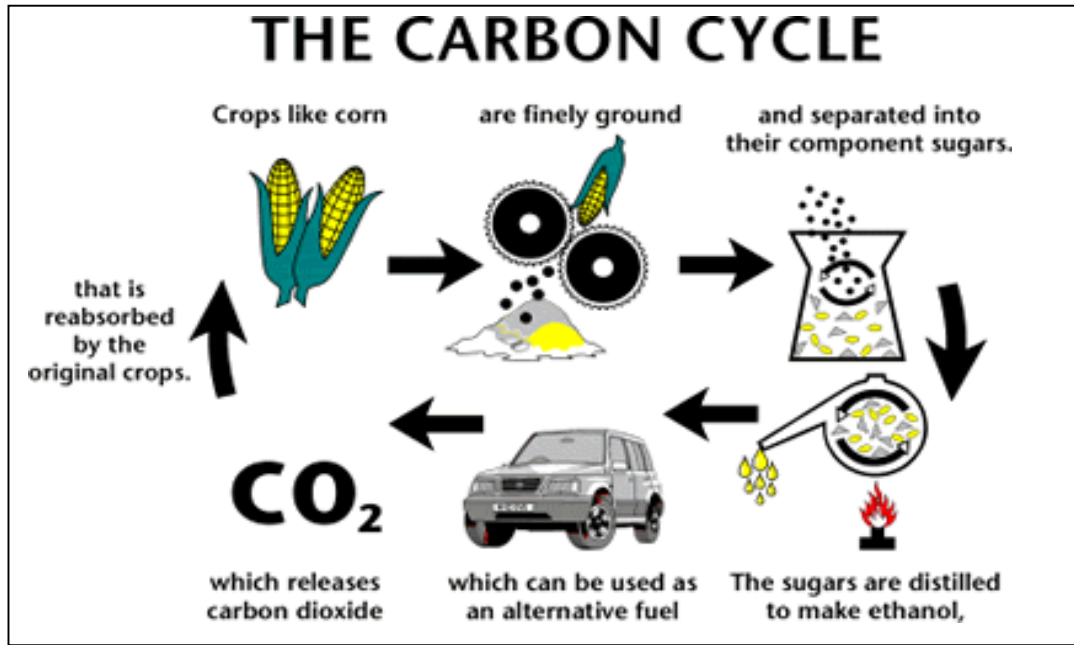

Figure 2.1 : The Carbon Cycle Process of using Ethanol

2.3 Determination of Cone and Dispersion Angles

2.3.1 Spray Cone Angle, Ψ

The spray cone angle Ψ of the conical diesel sprays is measured from the spray photos [7]. The spray cone angle in each captured photo was measured. The average reading of the spray cone angle was then calculated for the purpose of the investigation. The procedures for determining the spray cone angle, break up length, and spray tip penetration are as in Figure 2.2 below.

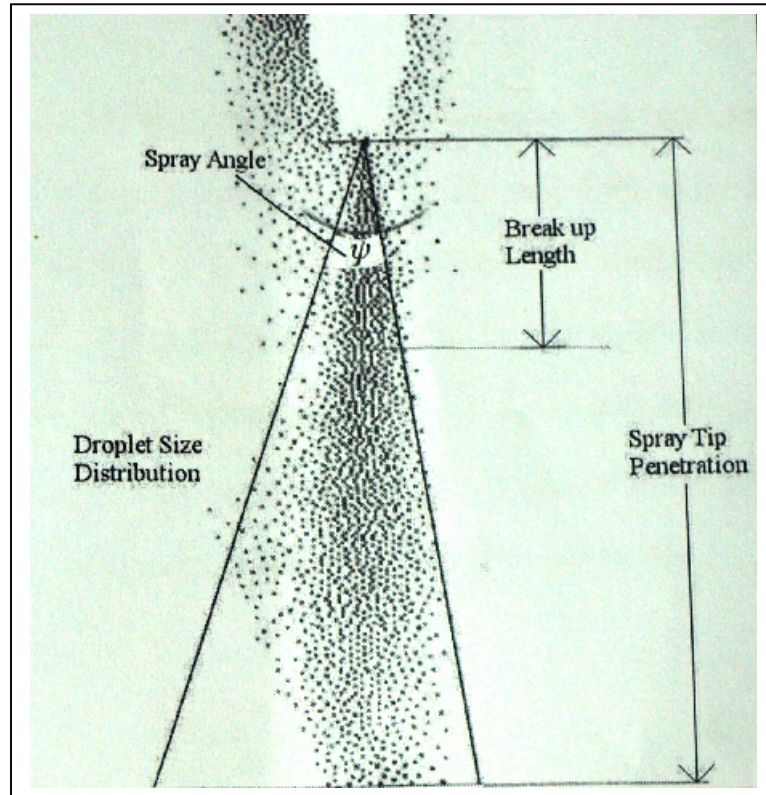

Figure 2.2 : Determination of Spray Cone Angle

2.3.2 Dispersion Cone Angle, ?

According to Xiaofeng, et al. 2000, the dispersion angle, ? can be determined as follows,

$$\tan \left(\frac{\theta}{2} \right) = C_a \frac{\rho_g}{\rho_f} \quad (2.1)$$

where C_a is an empirical constant, equal to 12.3, examined by the experimental data. P_g is the gas density. The above equation true for spray droplets that are characterized with one dimension i.e. sphere.

From the experimental photos, it was assumed that the droplet characteristics follows the assumption made by Xiaofeng, et al., 2000, therefore **Equation 2.1** is valid in predicting the dispersion cone angle for the density of the diesel is constant at 850kg/m^3 as it is an incompressible fluid. Furthermore, the ambient gas density was treated to vary for all the test conditions. The density of the ambient gas can be predicted from the ideal gas equation as follows : -

$$\rho = \frac{P}{RT} \quad (2.2)$$

where P is the operating pressure, R is the ideal gas constant and T is the temperature. By applying **Equation 2.2**, it shows that the density of gas varies from 164.8 kg/m^3 to 195.4 kg/m^3 . The dispersion angles were then determined by applying **Equation 2.1**.

As an example, consider the spray at 14.0 Mpa with gas constant, $R = 0.287 \text{ kJ/kg.K}$ and temperature, of 23°C (296K).

From **equation 2.2**:

$$\begin{aligned} \rho_g &= \frac{P}{RT} \\ \rho_g &= \frac{14.0 \times 10^3 \text{ kPa}}{(0.287 \text{ kJ / kgK})(296 \text{ K})} \\ \rho_g &= 164.8 \text{ kg / m}^3 \end{aligned}$$

Therefore, by applying **Equation 2.1**, the spray dispersion angle is given by : -

$$\begin{aligned} \tan \left(\frac{\theta}{2} \right) &= C_a \frac{\rho_g}{\rho_f} \\ \tan \left(\frac{\theta}{2} \right) &= 12.3 \left(\frac{164.8 \text{ kg / m}^3}{850 \text{ kg / m}^3} \right) \\ \left(\frac{\theta}{2} \right) &= \arctan (2.3848) \\ \theta &= 2 (67.25^\circ) \\ \theta &= 134.4^\circ \end{aligned}$$

2.4 Breakup hollow cone spray

The influence of the solid particle size, concentration and density as well as the effect of the carrier liquid on the breakup of a hollow cone suspension sheet was studied experimentally. The photographs of the sheet break-up have shown that the solid particles have an influence on the sheet break-up and its parameters. The increase of the solid particle concentration leads at first to increase the break-up length, a further increasing of the concentration leads to decrease the break-up length [8].

The effect of the concentration seems to be influenced by the carrier liquid. The solid particle size and density affect the perforation mechanism in the dilute suspensions. In this case solid particles with high relaxation time (large diameter or high density) can not follow the turbulent fluctuations in the liquid sheet that leads to enlarge the velocity difference between the particles and the liquid. Accordingly, the perforation mechanism is promoted by the solid particles. The experimental results presented in this study find a good agreement with the theoretical study [9].

Figures 2.3, 2.4, 2.5, and 2.6 show photographs of the break-up process of the hollow cone sheet of three different carrier liquids (water, Ethanol/water and Glycerol/water) and a high concentrated Clay/water-suspension ($C_p = 30\text{v.}\%$) at the injection pressure =

1.2bar. The photographs show that the hollow cone liquid sheets will disintegrate into ligaments and drops according to the aerodynamic waves.

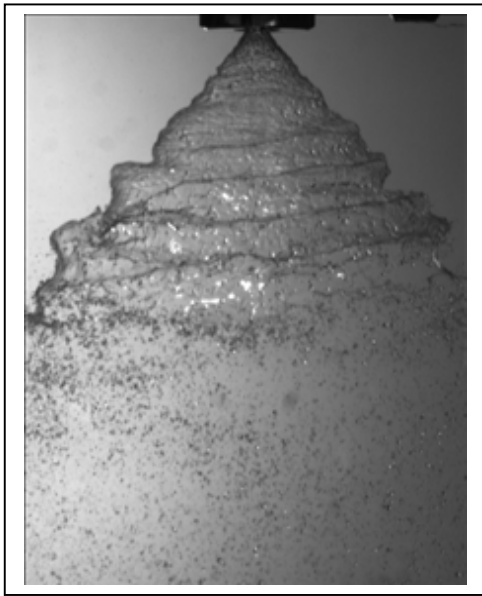

Figure 2.3 : Water

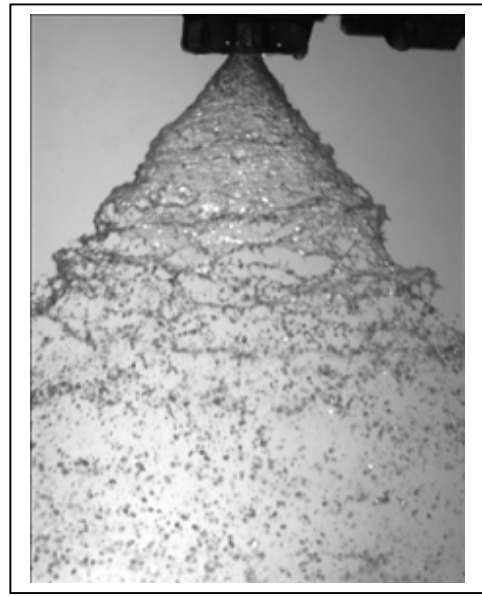

Figure 2.4 : Ethanol + Water



Figure 2.5 : Glycerol + Water

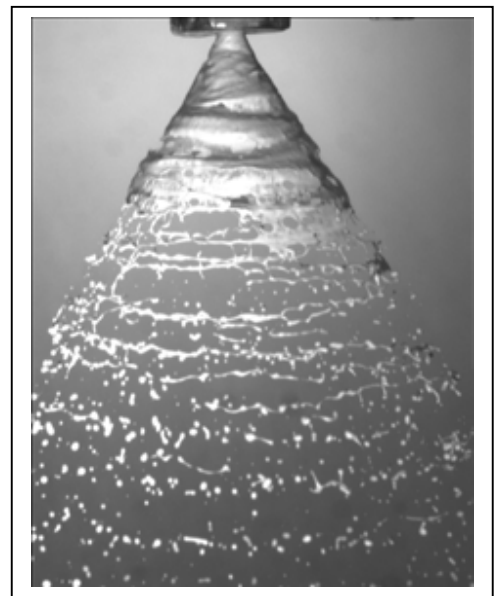

Figure 2.6 : Clay + Water

2.5 Pressure Atomizer

According to Jen Heinlin, et al. 2001, the pressure atomizer is studied at a constant mass flow rate of 0.003 kg/s at an spray angle of 65°. The experiments are performed by water [10]. Figures 2.7 and 2.8 show the spray characteristic of the pressure atomizer. Based on these figures it can be recognized that the spray did not exhibit a regular density in every part of the spray. It is rather shown that the spray is more dense in the core regions. This figures also show that the ligaments describe a pronounced undulation before the break-up process occurs.

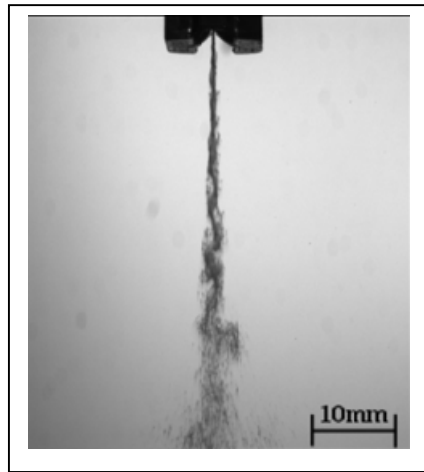

Figure 2.7 : Side view

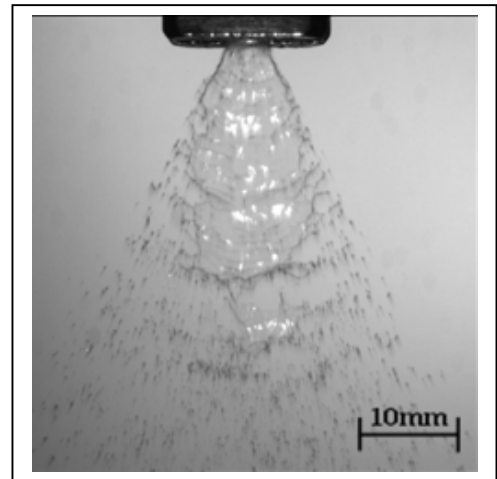

Figure 2.8 : Front view

2.6 Twin-fluid atomizer

The twin-fluid atomizer is operated at a constant liquid mass flow rate of 0.0007kg/s and different air volume flow rates of 0.11 l, 0.141, 0.181 and 0.221/s. The experiments are performed with water, the spray angle is 18°. Figures 2.9 and 2.10 illustrates the spray characteristic of the twin-fluid atomizer at different air flow rates.

Figure 2.10 shows that the spray did not exhibit a homogeneous density which is similar to the pressure atomizer shown in Figures 2.7 to 2.8. The highest droplet density here is likewise in the core range. It can be stated however that with increasing the air flow the droplet density distributes itself more evenly. It needs to be mentioned that the atomizer-manufacturer indicated a minimum air flow of 0.181 /s. The operating conditions represented in Figure 2.10.

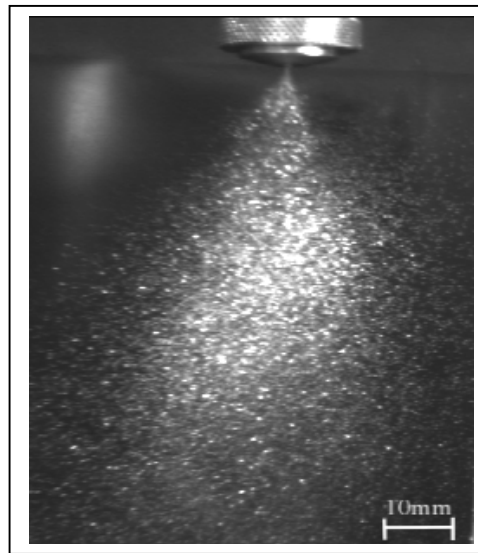

Figure 2.9 : Air atomizer at an air flow rate of 0.111/s

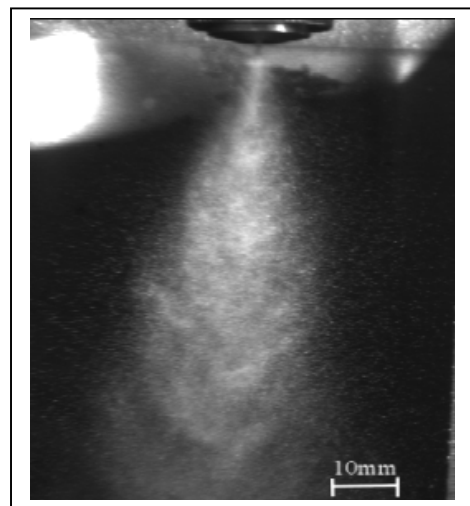

Figure 2.10 : Air atomizer at an air flow rate of 0.181/s

2.7 Imaging Spray Injection near Nozzle Region

According to G.wigley et al. 2006, the concept of the understanding physical processes and quantifying them in this region are judged vital to the future development of injection systems and predictive simulations tools. The combination of complementary diagnostics allows the morphology of the spray to be identified along with quantifying the velocity and drop size of the droplets formed. The development of the spray distribution is clearly performed when using the imaging analysis. Comprehensive time history profiles of droplet velocity, size and sample number were recorded. It used to indicate the times at which the spray exhibited different characteristics [11].

The timeframe and spray profile that have been determined such as below:

Table 2.1: The relation of the timeframe and spray profile

Timeframe (millisecond)	Spray profile
0.50	Pre-swirl spray
0.58	Spray cone start to develop
0.70	Spray cone relaxes
0.98	Maximum velocity in spray cone
1.40	Spray cone collapse
> 1.50	Spray detaches from the nozzle

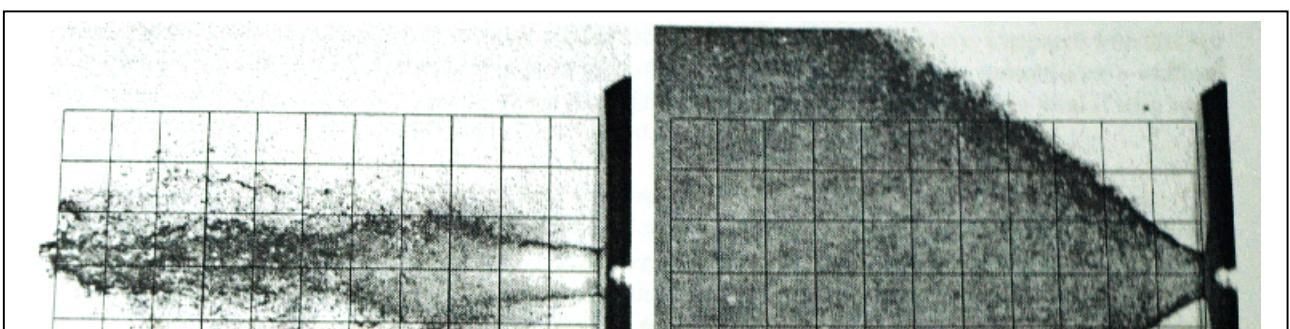

Figure 2.11: Single Shot Images of the Pre-Swirl Spray and Spray Cone

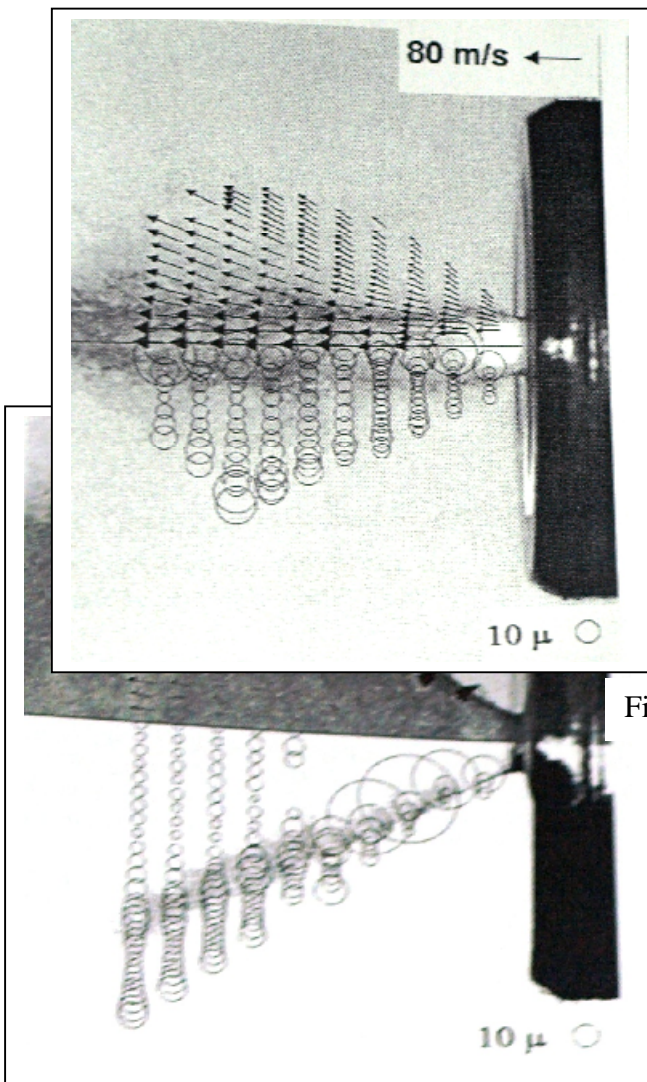

Figure 2.12: Pre-Swirl Spray

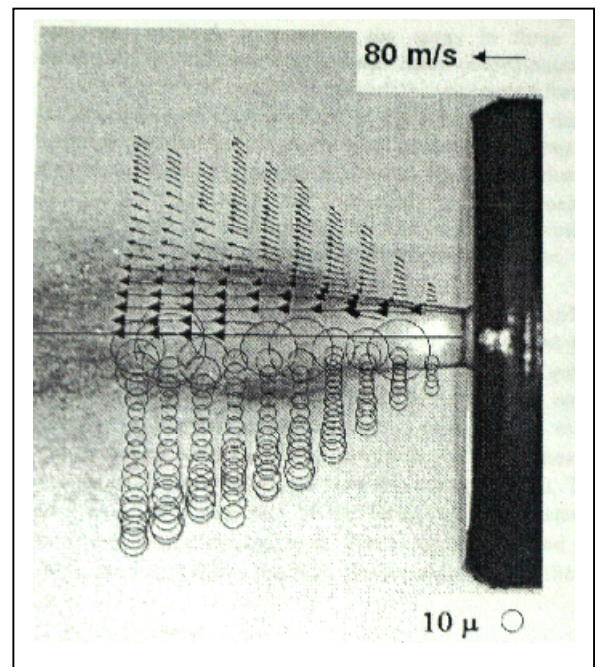
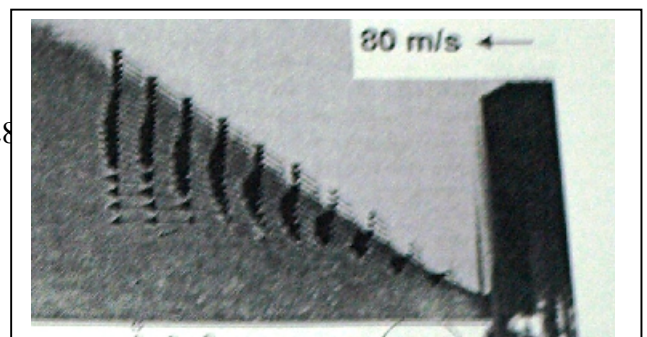

Figure 2.13: Spray Cone



ne Relaxes

Figure 2.15: Maximum Velocity in Spray Cone

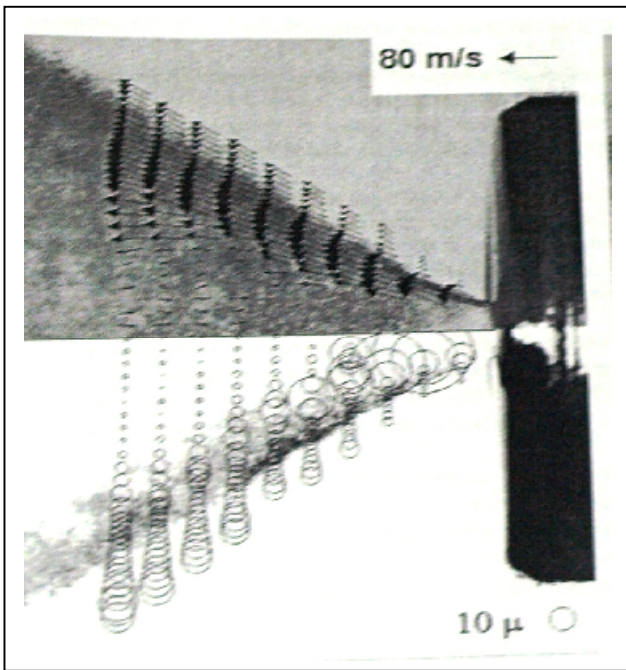

Figure 2.16: Spray Cone Collapse

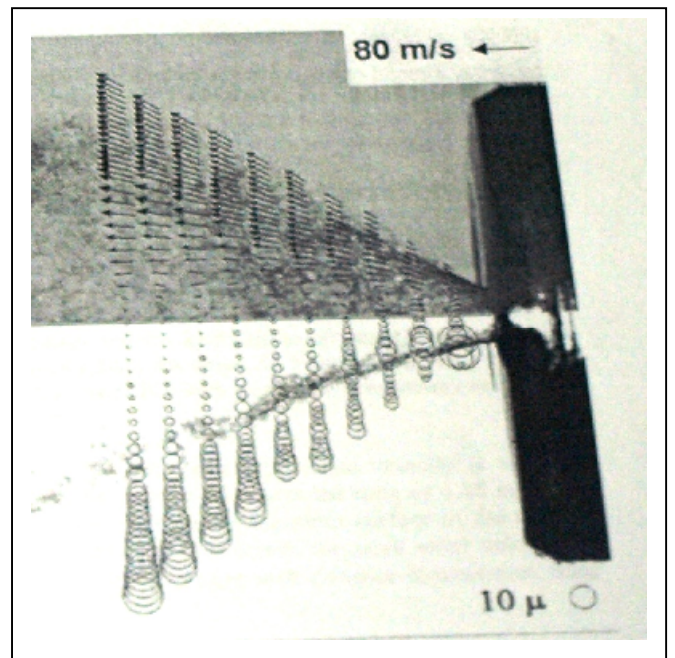
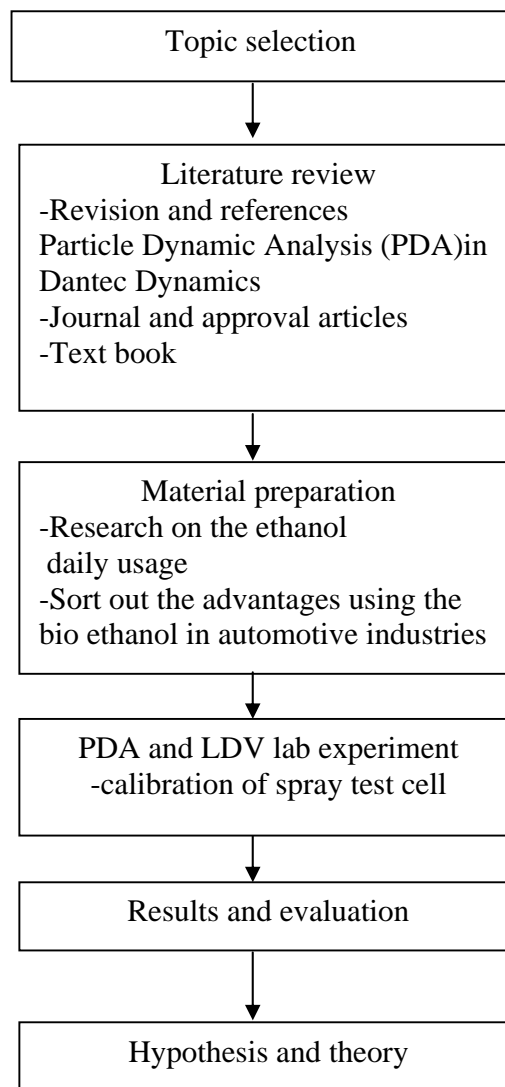

Figure 2.17: Spray Detaches from the Nozzle

CHAPTER 3 METHODOLOGY

3.1 Research Methodology



3.2 Project Progress Activity

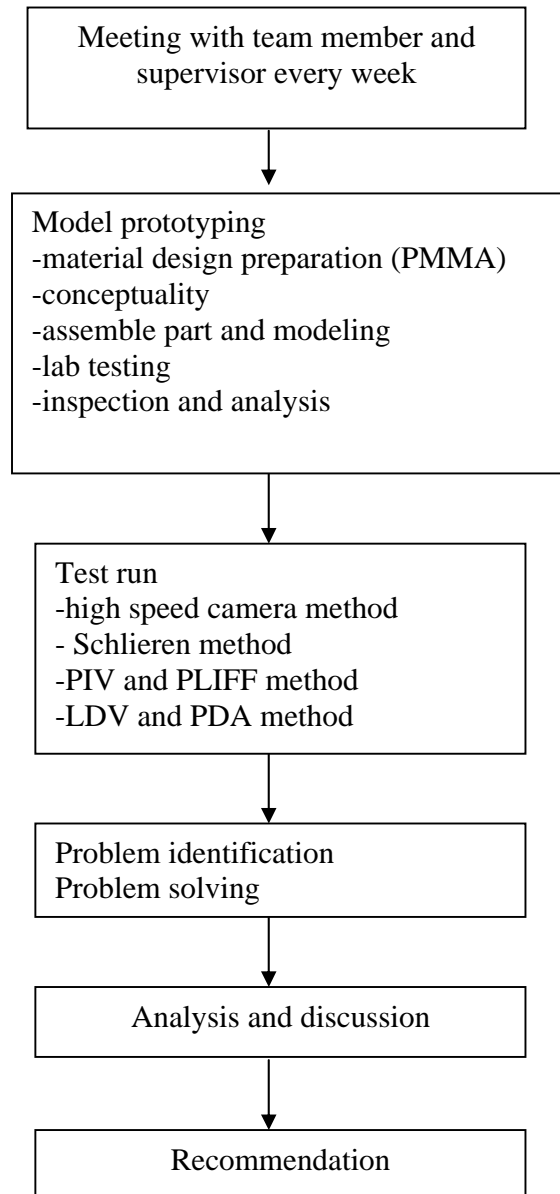

3.3 Pre-Experimental Procedures

3.3.1 Design and Fabrication

a Engineering Drawing

Once the details design phase have been finalized, the designs were drawn systematically for fabrication purposes. The most important equipment that need to be designed is the test chamber as an optical access during the injection process.

b Optical Access

The transparent material for the optical access or laser penetration used in the study was Perspex or scientifically known as PolyMethyl Methacrylate (PMMA). Based from one of the main PMMA material properties i.e. melting temperature of 100⁰C, PMMA can be utilized for the optical access material since the study was under non-firing engine condition. Note that PMMA has advantage of its availability, cheap and simple to machine.

3.4 Experimental Procedures

3.4.1 Laser Doppler Velocimetry (LDV) Principle

The basic components are the laser, a beam splitter, transmitting/ receiving optics, a photo detector, a signal processor and a data analysis system. A Bragg cell is often used as the beam splitter. It is a glass block with a vibrating piezo crystal attached. The vibration generates acoustical waves acting like an optical grid. The output of the Bragg cell is two beams of equal intensity with different frequencies. These are focused into optical fibers bringing them to a probe containing transmitting/ receiving optics.

In the probe, the parallel exit beams from the fibers are focused by lens into the measurement volume where the beams intersect. The measurement volume is typically a few millimeters long. The light intensity is modulated due to interference between the laser beams. This produces parallel planes of high light intensity, known as fringes. The fringes distance is defined by the wavelength of the laser light and the angle between the beams.

Flow velocity information comes from light scattered by tiny particles (seeding) carried in the fluid as they move through the measurement volume. It is collected by a receiving lens and focused on a photo detector, producing a signal at the Doppler frequency and the fringe distance.

The measurement of two velocity components, two extra beams can be added to the transmitting optics in a plane perpendicular to the first beams. All three velocity components can be measured by two separate probes measuring respectively two components and one component, with all the beams intersecting in a common measurement volume. Different wave lengths are used to separate the measured components.

3.4.2 Phase Doppler Anemometry (PDA) principle

The PDA technique is an extension of Laser Doppler Velocimetry (LDV) is based upon Phase Doppler principles. Two or more detectors collect the light scattered by single particles passing through the measurement volume.

The phenomena of light scattering can be visualize by tracing. The light which is incident on a water droplet is partially reflected in both forward and backward directions after one internal reflection. The scattered light intensity is not uniform in all directions and also depends on the relative refractive index.

The position of the receiver (scattering angle) must therefore be carefully selected to ensure that one light scattering mode is dominant. Commonly used scattering angle ranges are; 30° - 70° for refraction, 80° - 110° for reflection, 135° - 150° for second order refraction.

The maximum particle size that can be unambiguously measured with two detectors corresponds to a phase shift of the angle is 360° . Reducing the distance between the detectors can extend the particle size range. This however, will also reduce the measurement resolution. Using three detectors provide both a large measurement size range and a high measurement resolution. Figure 3.1 and 3.2 shows the Laser Doppler Velocimetry (LDV) and Phase Doppler Anemometry (PDA) configuration.

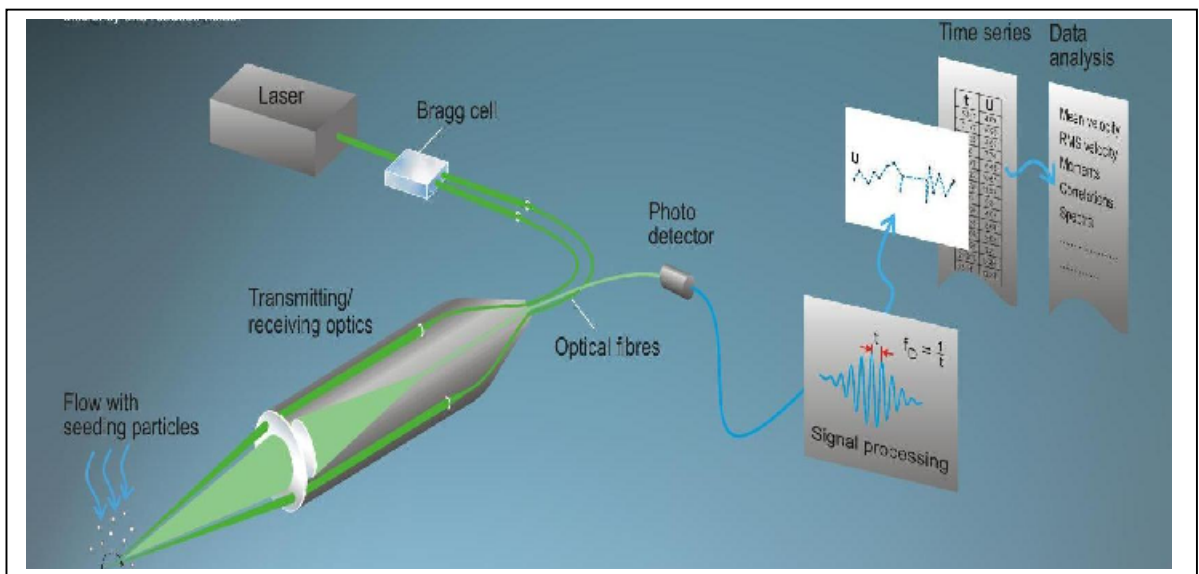

Figure 3.1 : Laser Doppler Velocimetry



Figure 3.2 : Phase Doppler Anemometry

3.4.3 Laser Transmission

In the study, the author decided to use backscatter mode since it is easier to align as compared to forward scatter mode. The procedures started by identifying the Backscatter Receiving Fiber-Optics (BRFO). All the optics cables connected to U1, U2, U3/V2 and V1 at the cable port which is located at the back Burst Spectrum Analyzer (BSA) Flow Processor were removed. BFOC cable was then connected to U1 and V1 of the cable port. This procedure was then continued with laser alignment.

3.4.4 Beam Focusing Point

In spite of the two beams (green) catering the X-axis, there are also another two beams (blue) catering for the Y-axis. All these four beams must be focused into one point, which is the beam alignment take place.

There will be thousands of fuel particles in the test chamber while the engine is running, however only the particles which are crossing the focusing point will be measured. In other words, the velocity measured is the velocity of the current fuel particle crossing the focusing point. Other than that point, the equipment will not be able to measure it. Figure 3.3 shows the details of the beam focusing point.

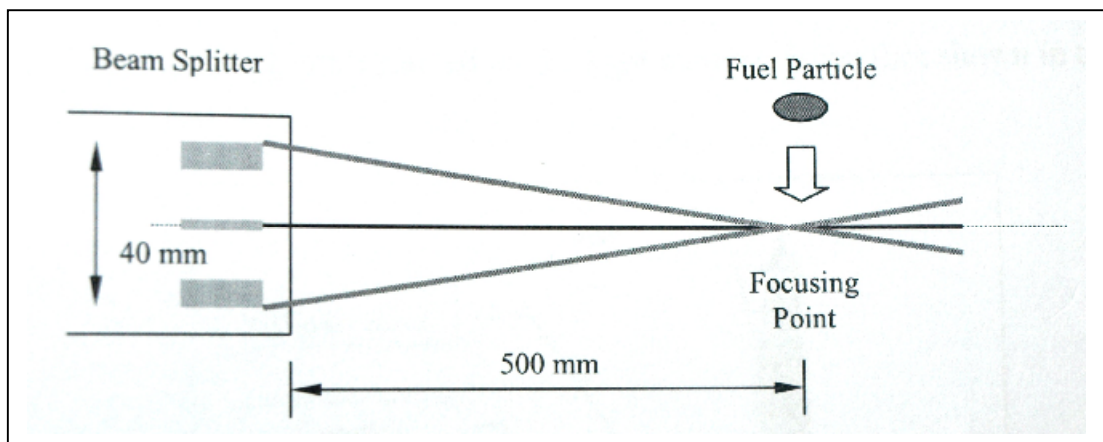

Figure 3.3 : Beam focusing point

3.4.5 Final Arrangement, Alignment and Calibration of Traverse System

The study exploits the Dantec 60X FiberFlow Series Optical unit which based on a four-beam system. The unit transmits two blue beams and two green beams. This allows 2D PDA velocities measurement. Also the PDA system came with PDA processor which called the Dantec Burst Spectrum Analyzer (BSA). The hardware to software interfacing for the BSA is run by a computer. Table 3.1 shows the PDA settings for the study :

Table 3.1: PDA Parameter Setting

Property	Optical PDA System U1	Optical PDA System U2
Wavelength	514.5 nm (green)	488.0 nm (blue)
Focal length	500 mm	500 mm
Beam diameter	2.2 mm	2.2 mm
Expander ratio	1.0	1.0
Beam spacing	40.0 mm	40.0 mm

In utilizing PDA system, pin-hole alignment is crucial to produce the best intensity to the laser beams. The alignment was done by focusing the receiving optics of the scattered light onto a central pin-hole. To simplify the alignment procedures, the pin-hole was mounted to a block. The receiving optics was adjusted so that it will focus to central of the pin-hole by tuning the traverse system. This method was done until the four beams with approximately the same intensity emerged at the wall surface.

3.4.6 Data Processing

The data processing is done by hardware, which take place in the BSA processor. The processor sent the calculated velocities to the computer. The computer then tabulated the data so that it can be interpreted in simple engineering presentation. The analysis will be in term of vertical and horizontal velocities and size of the distribution droplets.

3.5 Sample Test

There are three samples material that being used during the lab experiment. However, only water has been used during the trial testing due to limited amount of that particular substances. Trial testing need to be done to determine that all the equipments meet the requirements mentioned The main samples material that need to be used including the Ethanol 85 (E85), Ethanol 10 (E10) and gasoline. The results obtained need to be analyzed for each comparison.

3.6 Gantt Chart for the progress activity of Final Year Project II

No	Details	Week															
		1	2	3	4	5	6	7	8	9	10	11	12	13	14		
1	Project work continue	█	█	█								MID SEMESTER BREAK					
	Test chamber fabrication	█	█	█													
2	Submission of Progress Report I				█												
3	Project work continue				█	█	█	█									
	Engine testing				█	█	█	█									
	Prototype test running				█	█	█	█									
5	Submission of Preliminary Report II								█								
6	Discussion on PDA and LDV settings						█	█									
7	PDA lab testing							█	█	█							
8	Seminar (compulsory)										█						
9	E10,E85, gasoline testing								█	█				█			
10	Result interpretation								█	█				█	█		
11	Poster/Exhibition														█		
12	Submission of dissertation															█	
13	Oral presentation														█		
14	Submission of project dissertation														█		

3.7 Key milestone for the whole project

No.	Detail/ Week	1	2	3	4	5	6	7		8	9	10	11	12	13	14
1	Project Work Continue	█	█	█												
2	Submission of Progress Report 1				█											
3	Project Work Continue				█	█	█	█								
4	Submission of Progress Report 2									█						
5	Seminar (compulsory)										█	█	█			
5	Project work continue									█	█	█	█			
6	Poster Exhibition											█				
7	Submission of Dissertation (soft bound)													█		
8	Oral Presentation														█	
9	Submission of Project Dissertation (Hard Bound)															█

CHAPTER 4

RESULT AND DISCUSSION

4.0 Result and Discussion

In this following section, the principle findings and results obtained will be presented and discussed.

4.1 Findings and Analysis

Fuel spray shape, spray tip penetration, spray angle are usually used to characterize the overall spray structure. The images for the pure gasoline and ethanol-gasoline blends have been demonstrated by using high speed camera. Generally, those images demonstrate show that the spray developing patterns are very similar. However, as the spray develops with time, different structure is clearly observed in the spray tip region for each material have been used. This following configurations show the images for each samples that have been tested.



Figure 4.1 : Gasoline



Figure 4.2 : Ethanol-gasoline blend (E10)

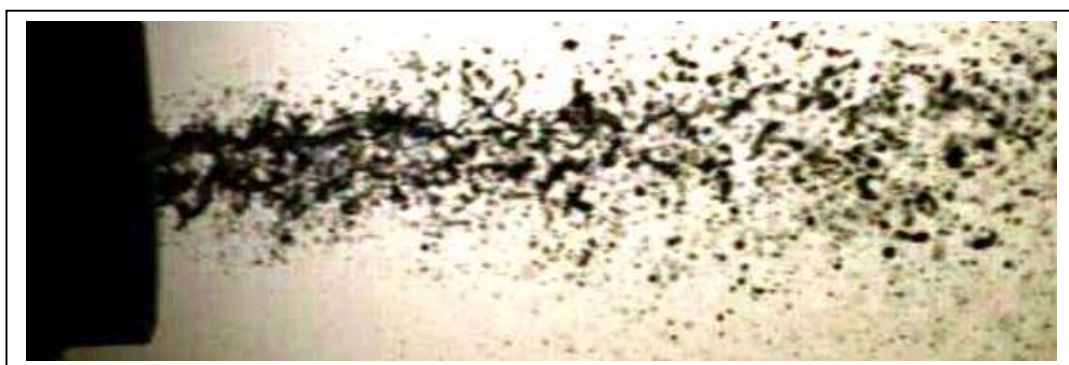

Figure 4.3 : Ethanol-gasoline blend (E85)

4.2 Velocity Distribution

Selected points at the certain area have been measured by using the Phase Doppler Anemometry (PDA) method. Velocity distribution for each sample was obtained and further analysis need to analysis for the comparison.

4.2.1 Gasoline

The datum point for the intersection laser beam can detect the spray injection is at the middle which is exactly 4mm from the injector. The datum point is very important to determine for capturing burst from the receiver beam. The burst only can be detected if the intersection laser beam at the middle of the spray injection. As a result, the middle point of the gasoline is at 4mm below the injector.

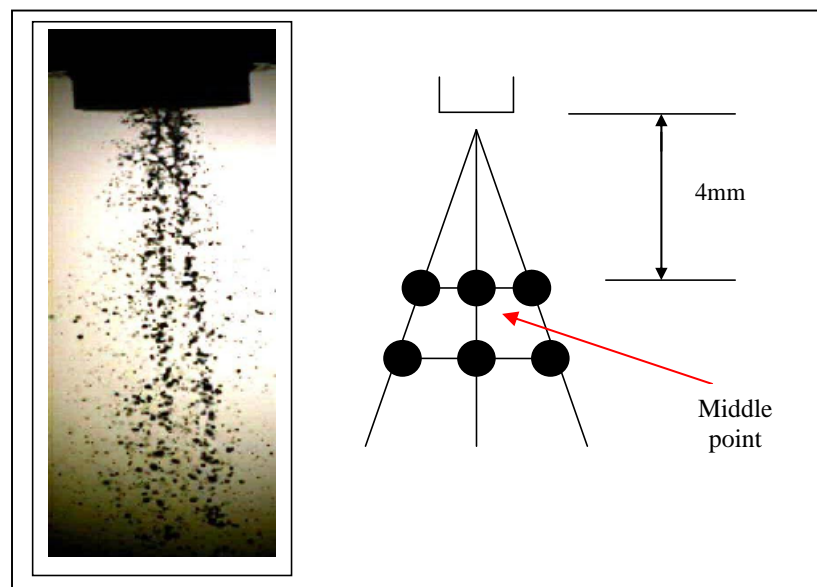
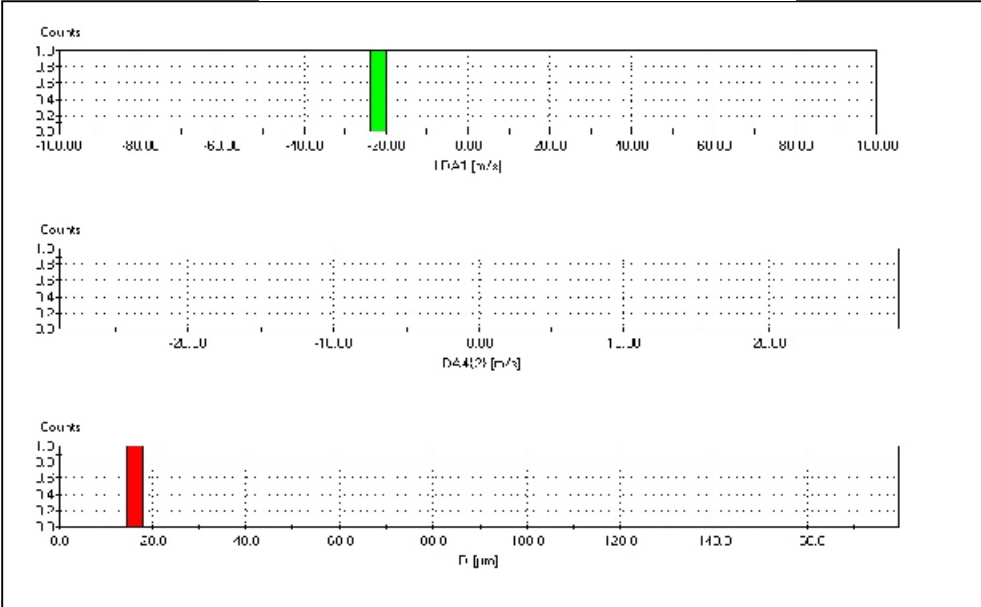

Figure 4.4 : Middle Point of Gasoline Spray

The velocity and size droplets at the middle that have been obtained from PDA method such as below:

Graph 4.1 : Middle Point



From the graph it shows that the value for horizontal velocity (green) is 25m/s and the diameter for droplet is 18 μm.

After determine the middle point of the injection, the laser beam have been moved to the left or positive side. The scale for each movement is 1mm either positive or negative side. The range movement for the gasoline either positive or negative is just only 2mm. The laser beam cannot detect the measurement value if it is pointed out of that range mentioned. It is because no more droplets that passed through the intersection point. The next point measurement is 1mm to the positive side from the datum point. The result shows the graph as :

Graph 4.2 : Positive 1mm (+1mm)

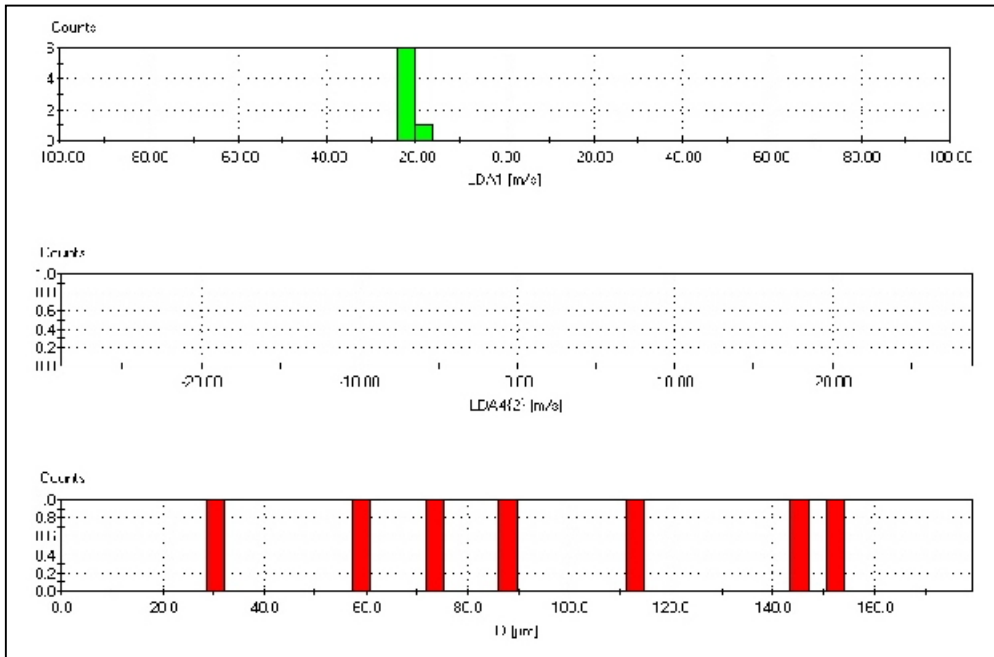

From the graph it shows that the value is horizontal velocity is 20m/s since its average of the two components velocity. The vertical velocity cannot be detected yet at this point. The average size droplet is 95 μ m.

Graph 4.3 : Positive 2mm (+2mm)

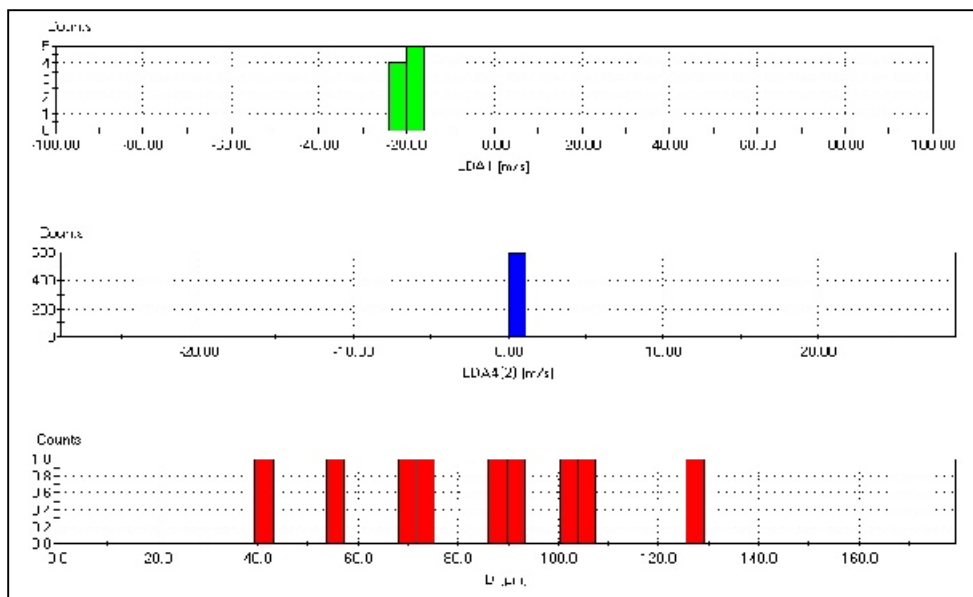

From the graph 4.3, the average horizontal velocity is 20 m/s, vertical velocity is 2 m/s and the average size droplet is 95 μ m. After the maximum range of the gasoline spray cone angle, the laser beam has been moved to the negative side from the middle point. The scale is same for every movement until it reached at the 2mm to the left. The results below show the measurement that have been taken :

Graph 4.4 : Negative 1mm (-1mm)

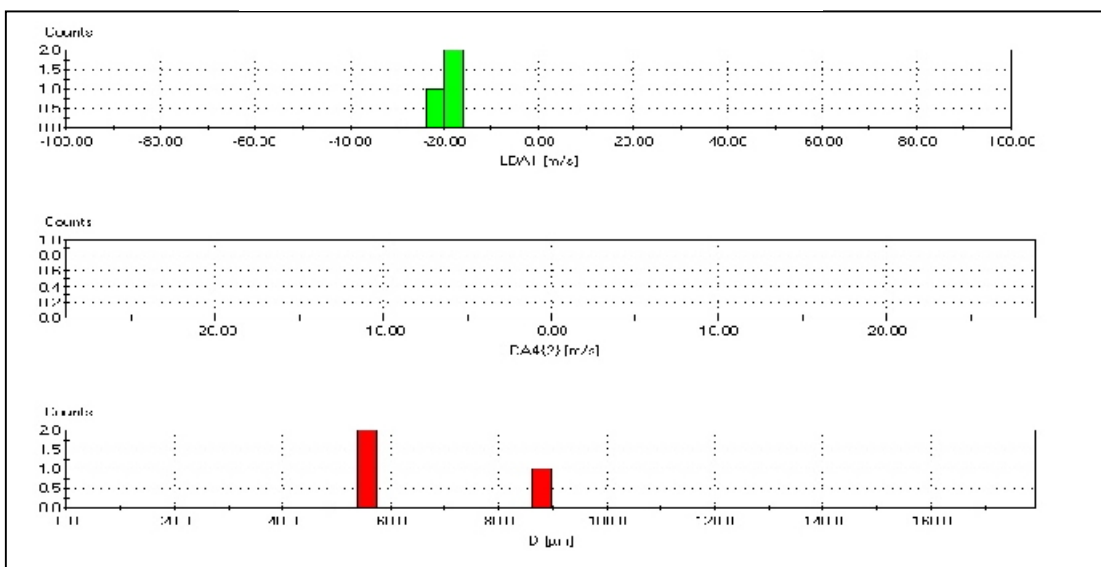

Graph 4.5 : Negative 2mm (-2mm)

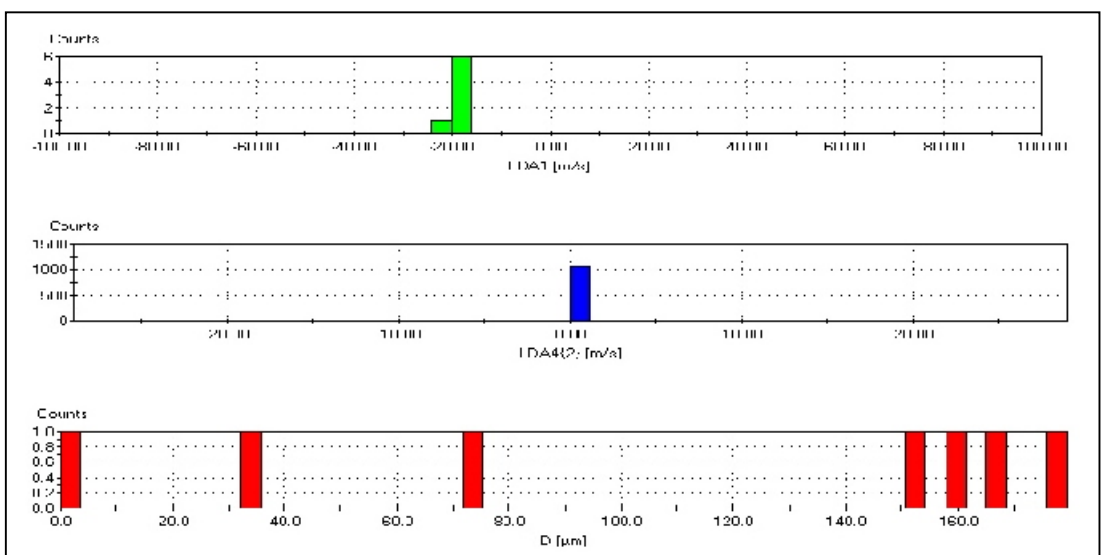

4.2.2 Ethanol-gasoline blend 85% (E85)

The measurement E85 is also the same like gasoline but the datum or middle point can be found at 3mm below the injector during the injection process. It shows that the spray cone angle is more wider compare to gasoline if refer to figure 4.3. The scale movement is also same as the previous setting which is 1mm, but the results found that the maximum range that the intersection laser beam can detect the droplet is 4mm either positive or negative side. The graphs below show the tabulated data at the critical point

Graph 4.6 : Middle Point

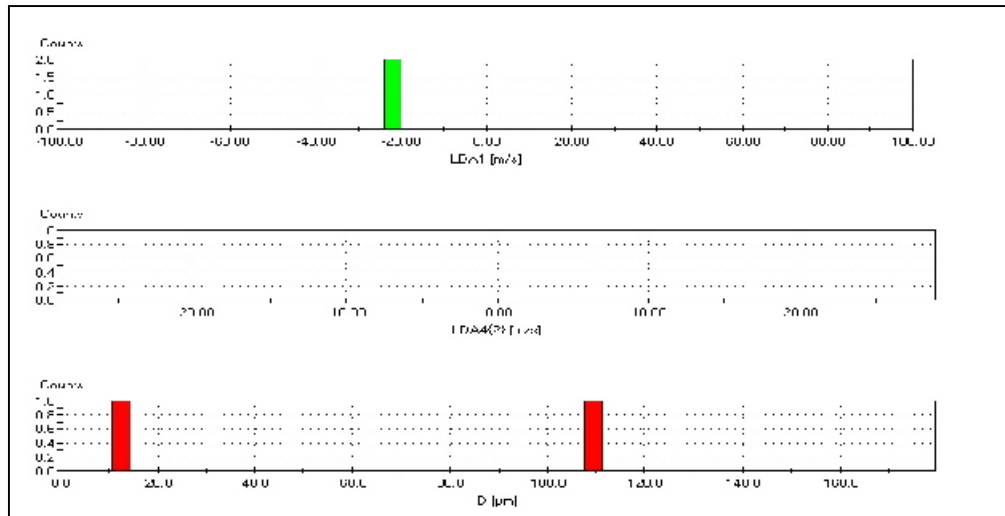

Graph 4.7 : Positive 4mm (+4mm)

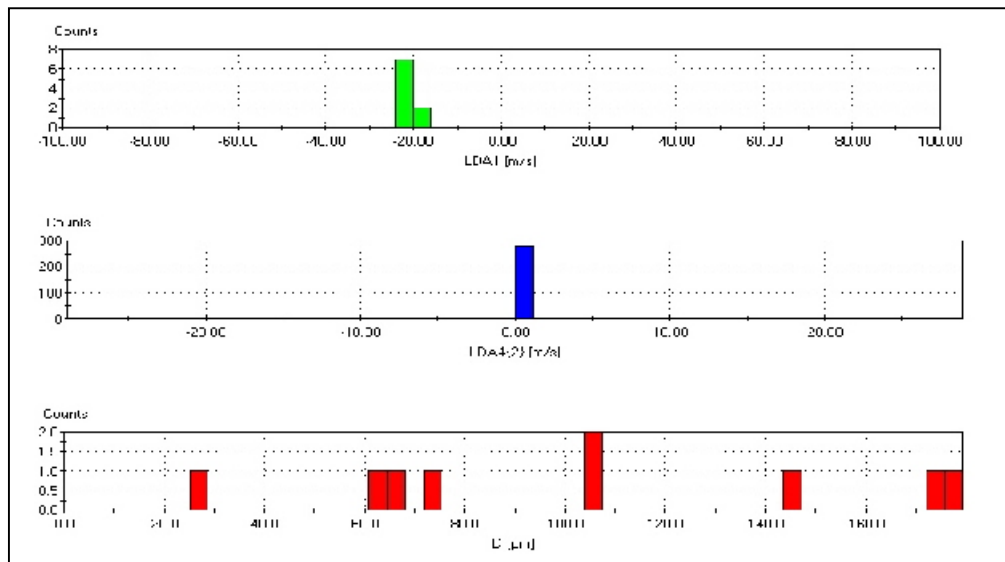

Graph 4.8 : Negative 4mm (-4mm)

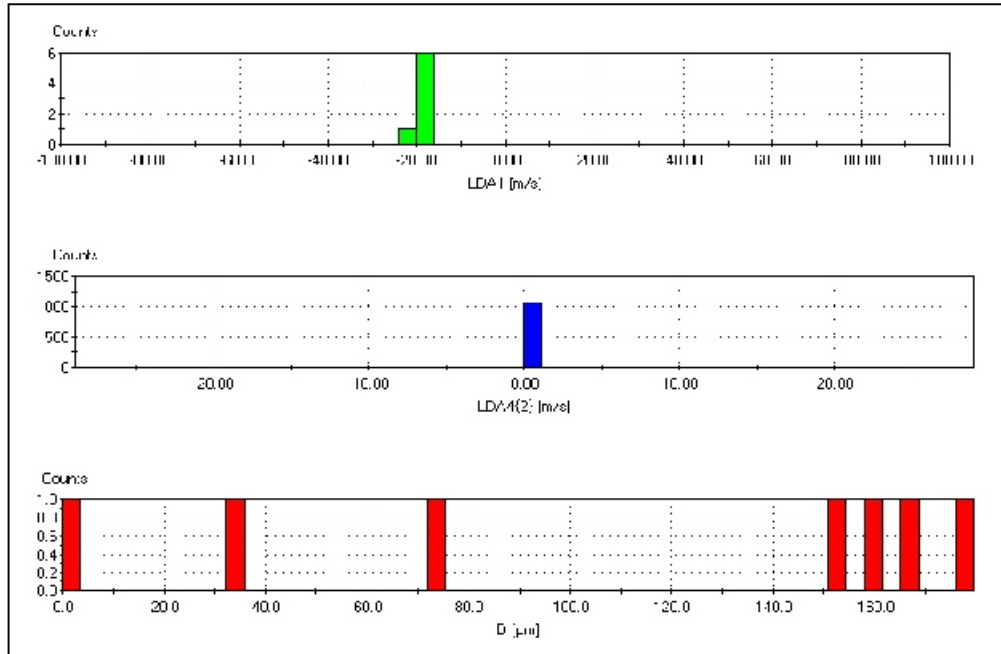

Table 4.1 shows the data at the critical point for E85 during the injection process.

Table 4.1 : E85 Critical Point Measurement

	Average horizontal velocity (m/s)	Average vertical velocity (m/s)	Average size droplet (μm)
Middle	25	0	62.5
+4mm	20	2	100
-4mm	20	2	115

4.2.3 Ethanol-gasoline blend 10% (E10)

The datum or middle point for the Ethanol-gasoline blend 10 (E10) is exactly at 3mm below the injector. The spray cone angle is more narrower than the E85 since the maximum range of the laser beam can detect the droplet that passed through is 3mm. The result have been approved by analysis in figure 4.2. It is shown that the spray distribution for E10 is more smaller range than E85. The graphs below show the E10 tabulated data for critical point during the spray injection.

Graph 4.9 : Middle Point

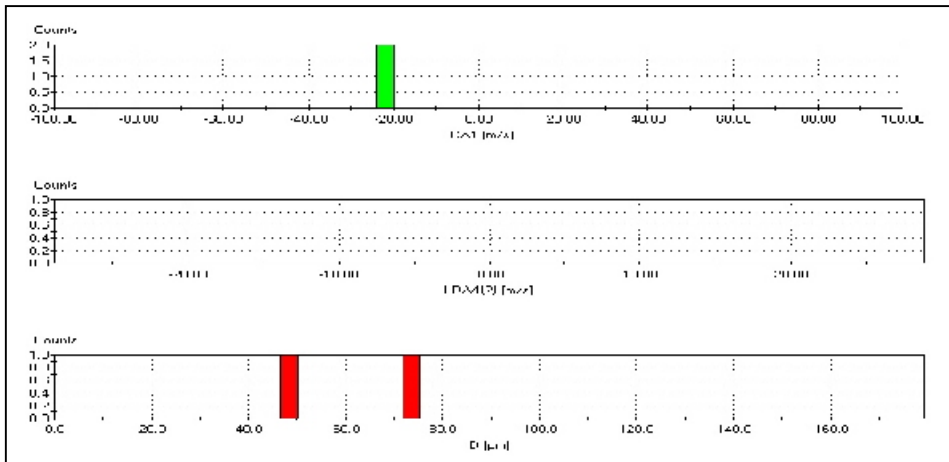

Graph 4.10 : Positive 3mm (+3mm)

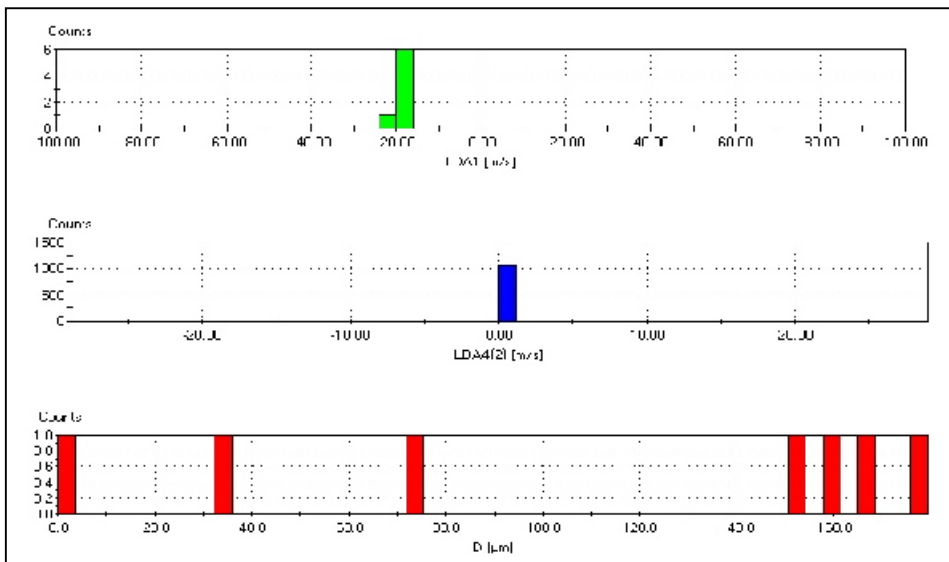

Graph 4.11 : Negative 3mm (-3mm)

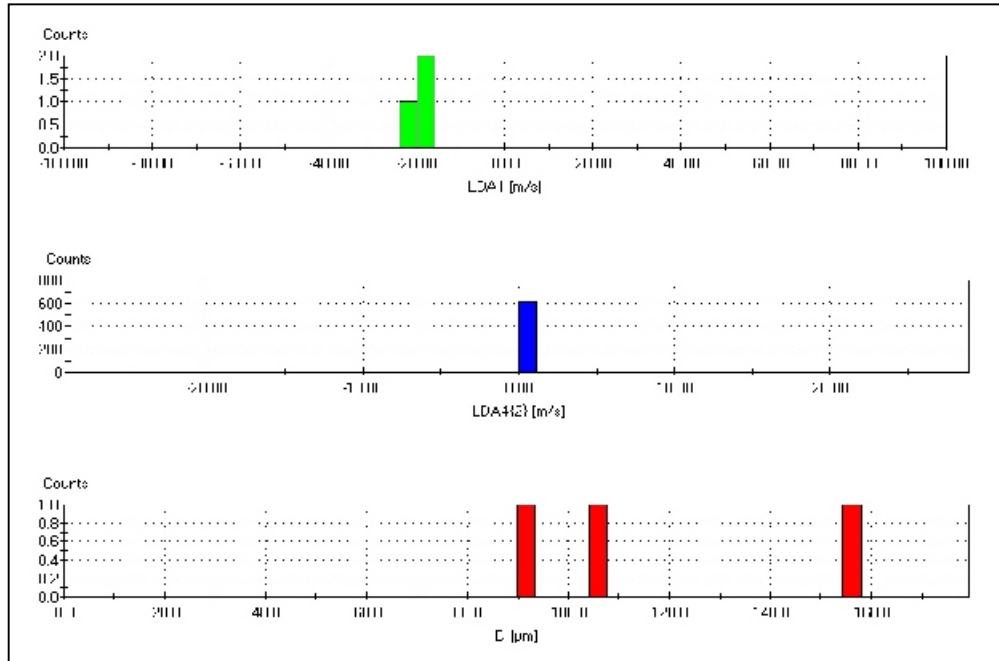

Table 4.2 shows the data at the critical point for E10 during the injection process.

Table 4.2 : E10 critical point measurement

	Average horizontal velocity (m/s)	Average vertical velocity (m/s)	Average size droplet (μm)
Middle	25	0	62.5
+3mm	20	2	115
-3mm	20	2	125

After all the results obtained, more explanation for each samples will be discuss for the next section.

4.3 Discussion

4.3.1 Spray Formation

It can be seen that all the sprays are assumed to have a bigger droplet size at the core region of the spray or at the edge of the maximum critical point. The internal pressure from the injector nozzle forced directly the droplets to move downward. When the force pushed out the certain amount of injections through the nozzle, not all the droplets have the same size at this moment. The remaining trickle of droplet might conceded out from the small outlet of the nozzle. When the laser beam detected the droplets that passed through the critical maximum point, the size of the droplets might be higher than the flow region.

4.3.2 Spray Evaporation

Spray evaporation rate for the gasoline-blend E10, E85 and gasoline are varied since each of the test sample has different density. Gasoline is a mixture of many components with various carbon atoms and structure, so its density is the highest among the other. The evaporation rate is inversely proportional to the density. From the figure 4.4, it is shown that the middle point of that substances to detect by the laser beam are varied. Gasoline has the highest amplitude compare to the other substance. Lower density of ethanol-gasoline blend tend to evaporate easily compare to the pure gasoline. Thus, the highest amplitude occurred at the middle point for the pure gasoline.

Beside that, the boiling point for the ethanol is lower compare to the pure gasoline. Furthermore, E85 will evaporate easier and faster after injected by the nozzle.

4.3.3 Spray Cone Angle

It can be shown from the results that the middle and maximum critical point varied for each test sample. Gasoline has very wide range of the middle point from the injector but the lowest maximum critical point range. It can be seen that the gasoline has the lowest cone angle roughly. However, it can be proved by the calculation below:

Gasoline

Middle point : 4mm

Maximum critical point : 2mm

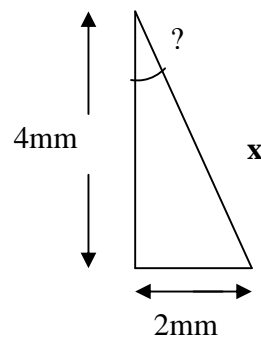

From the Theorem Pythagoras :

$$4^2 + 2^2 = x^2$$

$$16 + 4 = x^2$$

$$20 = x^2$$

$$x = 4.47 \text{ mm}$$

$$\cos ? = 4 / 4.47$$

$$\cos ? = 0.8944$$

$$? = 26.51^\circ$$

So the whole spray cone angle = $26.51^\circ \times 2$ (for the positive and negative side)

$$?_{\text{gasoline}} = 53.01^\circ$$

The calculations for both E85 and E10 are same to determine the spray cone angle.

E85

From the Theorem Pythagoras :

$$3^2 + 4^2 = x^2$$

$$9 + 16 = x^2$$

$$25 = x^2$$

$$x = 5 \text{ mm}$$

$$\cos ? = 3 / 5$$

$$\cos ? = 0.6$$

$$? = 53.13^0$$

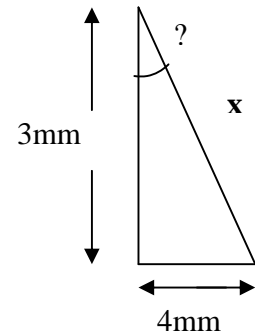

So the whole spray cone angle = $53.13^0 \times 2$ (for the positive and negative side)

$$?_{E85} = 106.26^0$$

E10

From the Theorem Pythagoras :

$$3^2 + 3^2 = x^2$$

$$9 + 9 = x^2$$

$$18 = x^2$$

$$x = 4.24 \text{ mm}$$

$$\cos ? = 3 / 4.24$$

$$\cos ? = 0.7071$$

$$? = 45^0$$

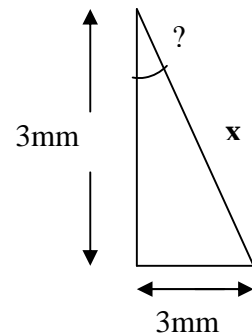

So the whole spray cone angle = $45^0 \times 2$ (for the positive and negative side)

$$?_{E10} = 90^0$$

It can be proved that the gasoline has the lowest spray cone angle compare to the other substances. Since having the lowest cone angle, gasoline has the highest tip penetration length. It is because the spray cone angle inversely proportional to the tip penetration length. Many variables such as density, evaporation rate and boiling point that have been mentioned earlier also will affect the cone angle size.

CHAPTER 5

CONCLUSION AND RECOMMENDATIONS

5.1 Conclusion

Overall, Phase Doppler Anemometry (PDA) and Laser Doppler Velocimetry (LDV) was successfully applied in the study of spray characteristics for pure gasoline and ethanol-gasoline blend E10 and E85. In the beginning stage, the test chamber was prepared to suit with the experiment environment. This is the most important consideration as an optical access for laser penetration beam and power transmission connection. Subsequently, comprehensive understanding on PDA is the main essence before commencing the investigations. The result indicate spray development patterns of blended fuels and pure gasoline. The velocity distribution and droplet size are observed. The maximum critical point region showed the highest size of droplet for each substance since it increasing from the middle point. The spray cone angle for each component varied with different variables such as density, evaporation rate and boiling point. Thus, higher density and boiling point of the substances may cause to decrease the spray cone angle since the evaporation rate slowly occurred. In addition, the spray tip penetration length increase when the amplitude of the cone angle reduced. This study is believed as a necessary preliminary research for the further analysis of internal mixture formation and atomization mechanism using ethanol-gasoline blends into the engines.

5.2 Recommendations

As a final point, the author would like to propose future works that are relevant to the study. Future works will involve the solutions on the currently problem occur. Due to queuing in using the equipment, the author was incapable to fix with the scheduling that have been provided. As a result, the investigation is very limited due to time constraint. Hence, it is recommended that future study would replicate the investigation and verify the validity results. Particle Image Velocimetry (PIV) or Planar Laser Induced Florescent (PILFF) as an alternative method that can be applied to validate the data. However, the utilization of the method is unavailable since limited experts that can handle the lab instrumentation. The future researchers can also work on the several samples of the ethanol-blends such as E5, E15, E20 until E100 to consolidate the data obtain. Lastly, it is suggested of using 3D PDA measurement instead of currently using 2D PDA measurement.

REFERENCES

- [1] “Fuel, Volume 87”, Issue 6, May 2008, Pages 925-932, Hyun Kyu Suh and Chang Sik Lee.
- [2] Xiaofeng, Y.,Yoshihisa, Y., and Atsushi, O., “Comparison of computed and Measured High-Pressure Conical Diesel Sprays”, SAE Paper 2000-02-0951, 2000
- [3] R. N. Parthasarathy, “Linear spatial analysis of the slurry sheets subjected to gas flow. Atomization and Sprays”, vol 9, pp. 519-540,1999
- [4] Photographic Observation of Break -up of Hollow Cone Suspension Sheet by Basel Mulhem, Ghaias Khoja, Udo Fritsching and Günther Schulte, University of Bremen.
- [5] “Bubble Break Up”, p58 Rodríguez-Rodríguez J, Gordillo JM, Martínez-Bazán C Departamento de Ingeniería Térmica y de Fluidos, Universidad Carlos III de Madrid
- [6] Jen Heinlen, Udo Fritsching, 2001, “Droplet Clustering in Sprays” , University of Bremen
- [7] G. Wigley, M. Goodwin, G. Pitcher, 2001, “Imaging and PDA Analysis of a GDI spray in the Near Nozzle Region”, aeronautical and Automotive Engineering, Loughborough University
- [8] B.Mandal, P.Barman, and A.kushari, 2002, “Study of primary atomization in helical passage pressure-swirl atomizer”

- [9] E.Palacios, A.Lecuona and P.A.Rodriguez, 2004 “On the experimental determination of the measurement volume diameter in the PDA technique”, ILASS-Europe 2005, Zurich, 2005
- [10] Dantec Dynamics, 1995, Fiber Flow Installation & User’s Guide, Dantec Dynamics, Denmark Publication No: 9040U2022
- [11] Dantec Dynamics, 2002, BSA Flow Software Installation & User’s Guide Vol.1, Dantec Dynamics, Denmark Publication No: 9040U5717
- [12] Effects of biodiesel on emissions of a bus diesel engine, Bio resource Technology, Volume 99, Issue 4, March 2008, Pages 863-873, Breda Kegl
- [13] International Journal of Heat and Fluid Flow, Volume 29, Issue 1, February 2008, Pages 131-148, Anna A. Pavlova, Kiyoshi Otani and Michael Amitay
- [14] Surface and Coatings Technology, Volume 202, Issue 9, 1 February 2008, Pages 1681-1687 Xian-Jin Ning, Jae-Hoon Jang, Hyung-Jun Kim, Chang-Jiu Li and Changhee Lee
- [15] International Journal of Heat and Fluid Flow, Volume 29, Issue 1, February 2008, Pages 131-148, Anna A. Pavlova, Kiyoshi Otani and Michael Amitay

APPENDICES

APPENDIX A-1

LIST OF APPENDICES

APPENDICES A-1 : TEST CHAMBER 3D DRAWING

Test chamber

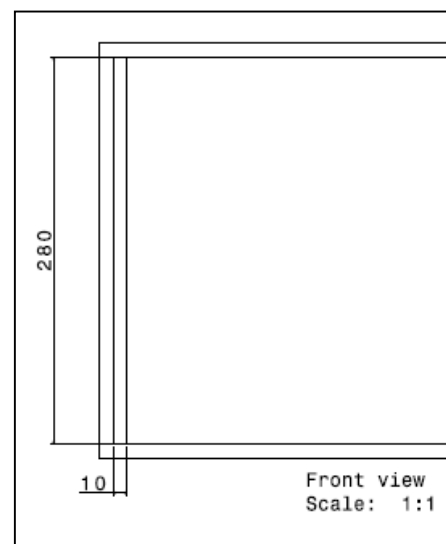
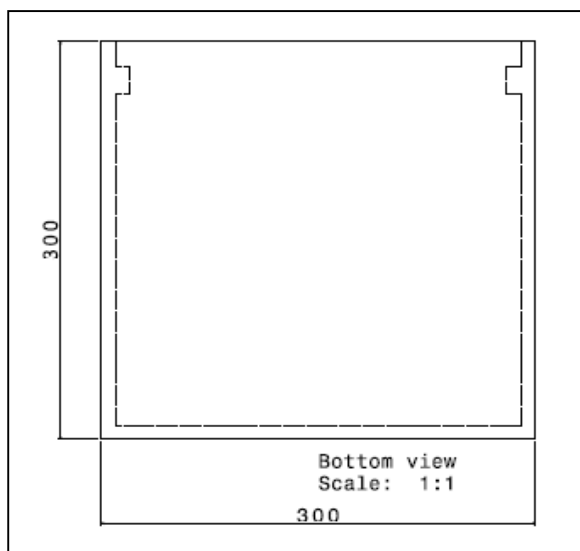
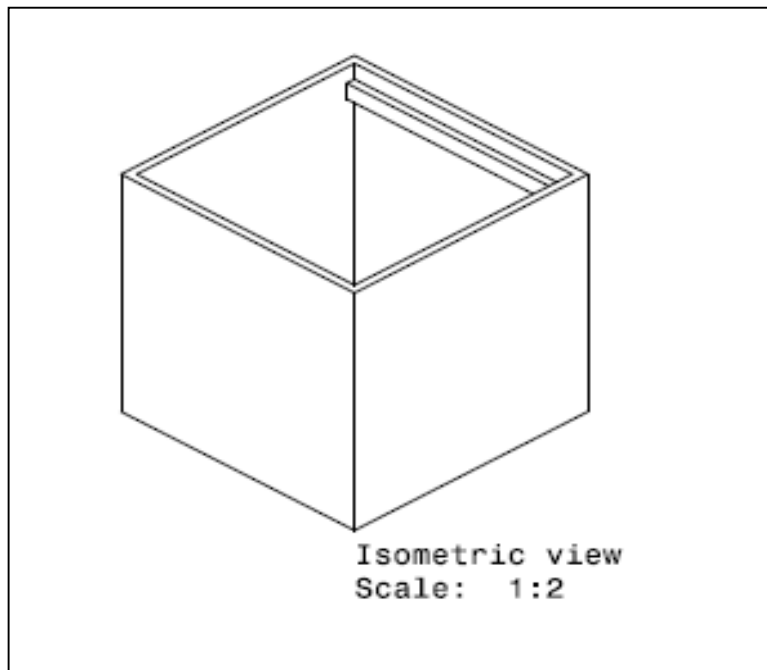

Top Cover

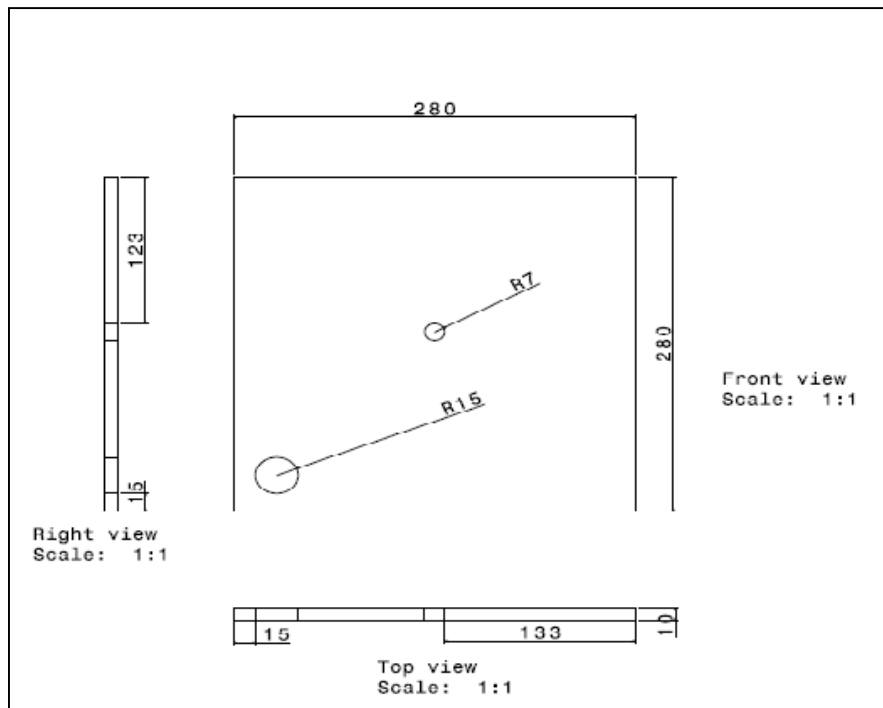
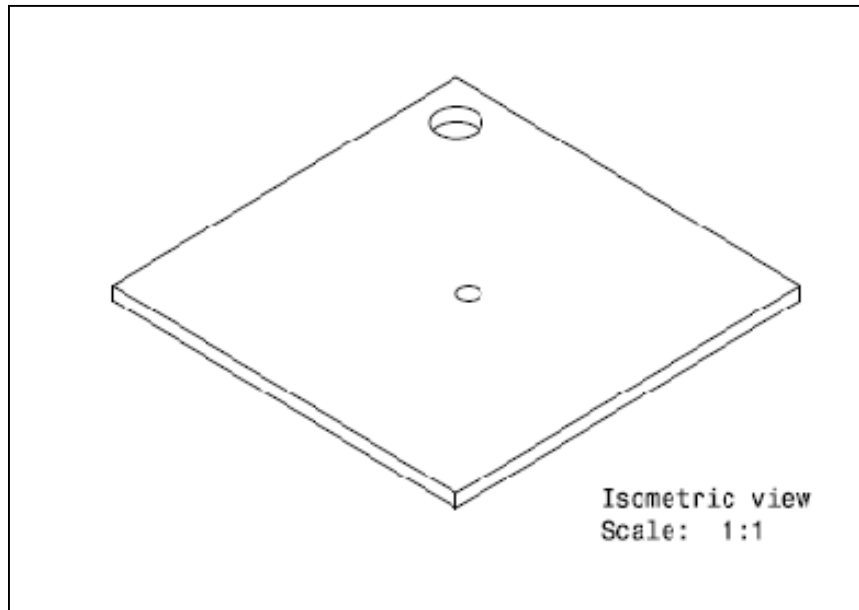

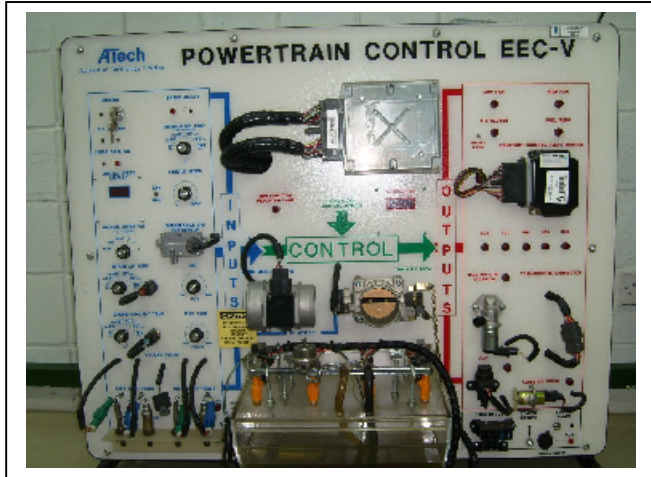

Power Train Control Board



Top Cover



Injector and Fuel Rail

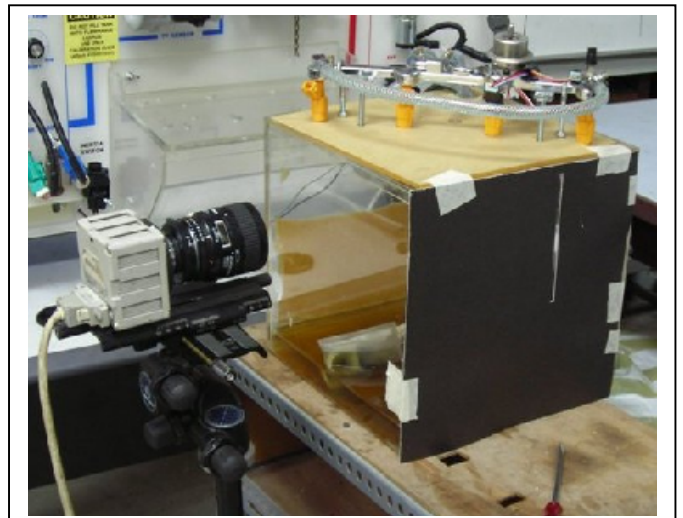

Test Chamber and High Speed Camera