

**Characteristic of Triplen Harmonics
in Low Voltage Network**

By

Mohamad Hisham B Mohamad Nasir

**A project dissertation
submitted in partial fulfillment of
the requirements for the
Bachelor of Engineering (Hons)
(Electrical & Electronics Engineering)**

May 2011

Universiti Teknologi PETRONAS

Bandar Seri Iskandar

31750 Tronoh

Perak Darul Ridzuan

CERTIFICATION OF APPROVAL

Characteristic of Triplen Harmonics in Low Voltage Network

By

Mohamad Hisham B Mohamad Nasir

A project dissertation
submitted in partial fulfillment of
the requirements for the
Bachelor of Engineering (Hons)
(Electrical & Electronics Engineering)

Approved:

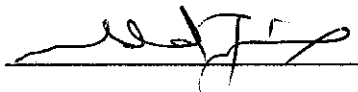

Ir. Mohd Faris B Abdullah
Project Supervisor

12/5/11

May 2011

Universiti Teknologi PETRONAS
Bandar Seri Iskandar
31750 Tronoh
Perak Darul Ridzuan

CERTIFICATION OF ORIGINALITY

This is to certify that I am responsible for the work submitted in this project, that the original work is my own except as specified in the references and acknowledgements, and that the original work contained herein have not been undertaken or done by unspecified sources or persons.



MOHAMAD HISHAM B MOHAMAD NASIR

ABSTRACT

Triplen harmonics study for harmonics produced by non-linear loads and salient pole synchronous generator is very important because their presence have caused communication line interference, damage to neutral earthing resistor etc. The purpose of this project is to study the characteristics of triplen harmonics under balanced/unbalanced resistive/inductive/capacitive loads, different generator neutral earthing resistor values and various transformer winding configurations. Lab scale non-linear load and salient pole synchronous generator is used for the experiment and third harmonic currents are recorded for analysis to represent triplen harmonics currents characteristics. Results from the under balanced load experiment shows that third harmonic current is inversely proportional to load impedance and neutral current is three times the phase current. During unbalanced load condition, the magnitude current is different for each phase and the neutral current is lower than arithmetic sum of phase current due to different phase current magnitude and angle. The phase and neutral third harmonic currents magnitude is inversely proportional to generator NER resistance under balanced load. Transformer winding configurations under balanced load permit third harmonic current flowing through them in accordance to zero sequence network for the transformer apart from higher transformer reactive impedance at third harmonic.

ACKNOWLEDGEMENT

First of all, I would like to express my gratitude to God for giving me the strength and health to complete this project. Not forgotten to my parents and my family members for providing advises.

I would like to thank my supervisor, Ir. Mohd Faris B Abdullah for sharing his knowledge and giving me the support and guidance throughout the project. I also would like to thank to my laboratory technician, Mr. Zuraimi and Mr. Yasin for assisting me to do some electrical wire connection.

My appreciation to Universiti Teknologi PETRONAS especially Electrical and Electronics Engineering Department, by providing me the necessary assets and resources, not only to accomplish my task, but also to enrich my knowledge further.

Finally, I offer my regards to those who support me especially all my friends and technicians in Electrical and Electronics Department for contributing their assistance and ideas for this project.

TABLE OF CONTENTS

ABSTRACT	iii
ACKNOWLEDGEMENT	iv
LIST OF FIGURES	vii
LIST OF TABLES	ix
CHAPTER 1 INTRODUCTION	1
1.1 Background study	1
1.2 Problem statement.....	2
1.3 Objectives and scope of study	3
CHAPTER 2 LITERATURE REVIEW	4
2.1 Harmonics.....	4
2.2 Total harmonic distortion	6
2.3 Low voltage networks.....	7
2.4 Non-linear load	7
2.5 Salient pole synchronous generator	8
CHAPTER 3 METHODOLOGY	9
3.1 Procedure identification.....	9
3.2 Research methodology.....	10
3.3 Project activities.....	10
3.3.1 <i>First phase experiment</i>	10
3.3.2 <i>Second phase experiment</i>	11
CHAPTER 4 RESULTS AND DISCUSSION	17
4.1 Non-linear load	17
4.1.1 Battery charger.....	18
4.1.2 <i>Laptop</i>	19

4.1.3 Printer	20
4.1.4 Radio	21
4.1.5 Television.....	22
4.1.6 Fan	23
4.2 Synchronous generator	24
4.2.1 Load variation.....	24
4.2.2 Generator <i>NER</i>	31
4.2.3 Transformer winding configurations	32
CHAPTER 5 CONCLUSIONS AND RECOMMENDATION	36
5.1 Conclusions.....	36
5.2 Recommendation	37
REFERENCES.....	38
APPENDIX.....	40

LIST OF FIGURES

Figure 1	Near sine wave	5
Figure 2	Distorted current waveform	5
Figure 3	Workflow Chart.....	9
Figure 4	One line diagram indicating measuring point	11
Figure 5	Diagram for 2 nd phase experiment	12
Figure 6	Third harmonic current vs. non-linear load	17
Figure 7	Battery Charger Voltage and Current waveform	18
Figure 8	Battery charger triplen harmonics current	18
Figure 9	Laptop Voltage and Current waveform	19
Figure 10	Laptop triplen harmonics current	19
Figure 11	Printer Voltage and Current waveform	20
Figure 12	Printer triplen harmonics current	20
Figure 13	Radio Voltage and Current waveform	21
Figure 14	Radio triplen harmonics current	21
Figure 15	Television Voltage and Current waveform	22
Figure 16	Television triplen harmonics current	22
Figure 17	Fan Voltage and Current waveform	23
Figure 18	Fan triplen harmonics current	23

Figure 19	Third harmonic current vs. balanced resistive load	24
Figure 20	Third harmonic current vs. balanced inductive load	25
Figure 21	Third harmonic current vs. balanced capacitive load.....	25
Figure 22	Third harmonic current vs. balanced resistive + inductive load	26
Figure 23	Third harmonic current vs. balanced resistive + inductive + capacitive load	27
Figure 24	Third harmonic current vs. unbalanced resistive load	28
Figure 25	Third harmonic current vs. unbalanced inductive load	29
Figure 26	Third harmonic current vs. unbalanced capacitive load	29
Figure 27	Third harmonic current vs. unbalanced resistive + inductive load.....	30
Figure 28	Third harmonic current vs. unbalanced resistive + inductive + capacitive load.....	30
Figure 29	Third harmonic current vs. generator NER value.....	31
Figure 30	Third harmonic current for delta-delta transformer configuration	32
Figure 31	Third harmonic current for delta-wye transformer configuration	33
Figure 32	Third harmonic current for wye-delta transformer configuration	34
Figure 33	Third harmonic current for wye-wye transformer configuration	35

LIST OF TABLES

Table 1	Non-linear loads rating	11
Table 2	Laboratory equipment rating.....	12
Table 3	Balanced Resistive load	13
Table 4	Balanced Inductive load.....	13
Table 5	Balanced Capacitive load	13
Table 6	Unbalanced Resistive load.....	14
Table 7	Unbalanced Inductive load.....	14
Table 8	Unbalanced Capacitive load.....	14
Table 9	Combination Unbalanced Resistive Inductive load	15
Table 10	Combination Unbalanced Resistive Inductive and Capacitive load	15
Table 11	Generator NER.....	15

CHAPTER 1

INTRODUCTION

1.1 Background study

Harmonics have existed in power systems for many years. In the past, harmonics represented less of a problem due to a conservative design of power equipment. However, they have magnified nowadays with the increased use of non-linear devices and produces non-sinusoidal current when supplied with a sinusoidal voltage, and vice-versa [1]. This keeping harmonic distortion in distribution networks on the rise.

Harmonics get more complicated in three phase applications where in these applications the industry need to deal with phase conductors, neutral conductor, sequence harmonics and triplen harmonics.

1.2 Problem statement

Synchronous generator and non-linear loads in the electrical system are source of harmonic distortion of both the voltage and current signals. This is one of the major quality concerns in electric power industry. This harmonics have the ability to cause the voltage and current waveforms become distorted.

The magnitude of the triplen harmonics current produced three times the phase current at the neutral conductor [2] [3]. The excessive current in the neutral conductor can cause higher-than-normal voltage drops between the neutral conductor and ground.

When the linear loads are subjected to harmonics voltage distortion, they will draw a non-linear harmonic current. For example in distribution transformers, harmonics currents can cause increased heating, due to iron and copper losses, in motor and generators. This increased heating can reduce the life of the electrical device as well as the electrical device efficiency.

The other bad impact that causes by the triplen harmonics are increased cooling load on buildings, increased heating in cables, nuisance tripping of breakers and malfunction of communications and data processing equipment. More details information already has been discuss in [4] and [5].

1.3 Objective and Scopes of study

There are four main objectives of this project which are stated as below:

1. To study the behaviour of the triplen harmonics in the non-linear loads
2. To study the behaviour of the triplen harmonics under balanced and unbalanced loads
3. To study the influence of neutral earthing resistor (NER) to the triplen harmonics
4. To study the influence of different transformer configuration winding to the triplen harmonics

The scopes of study in this project are:

1.3.1 Lab modeling and measurement

The scope of research is confine to perform the lab modeling using the Lab-Volt device such as generator, load impedances, record and measure the voltage and current harmonics waveform.

1.3.2 Data analysis

Data analysis is to understand the behavior of the triplen harmonic in the power system.

CHAPTER 2

LITERATURE REVIEW

2.1 Triplen Harmonics

One of the major power quality concerns in electric power industry is the distortion of sinusoidal voltage and current waveforms that caused by harmonics. The harmonics generated by the proliferation of non-linear loads have been dividing into three types that are positive-sequence harmonics, negative-sequence harmonics and zero-sequence harmonics.

Zero sequence harmonics also is known as triplen harmonics. Triplen harmonics are sinusoidal voltages or currents that are multiple odd numbers of third order harmonics. Triplen harmonics is the third order harmonics, nine order harmonics, fifteen order harmonics and so on [6].

In three phase AC circuits which contain balanced linear loads, the sinusoidal waveforms for voltage, current and power remain proportionally related as well, and there is no net current flowing in the neutral. The situation changes when non-linear loads are imposed on one or more phases.

Most of the three phase branch circuits contain a single neutral conductor for all three phase conductors. This is a safe arrangement when the neutral current is zero, or at worst, equal to the current in any single phase. Even numbered harmonic currents cancel out on the neutral; whereas triplen harmonics do not. Instead, they add up algebraically in the neutral conductor. When the neutral current is higher than the phase current, the solitary neutral conductor is in danger of overheating [7].

Figure 1 below show a normal 60-cycle power line voltage appears on the oscilloscope as near sine wave. When harmonics are present, the distorted waveform is produce as shown in Figure 2 below [8].

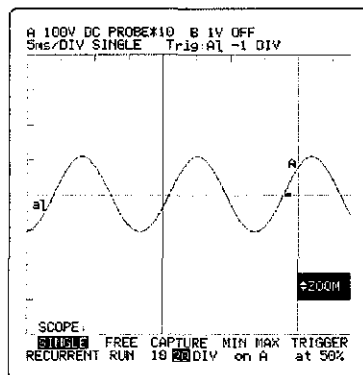

Figure 1: Near sine wave

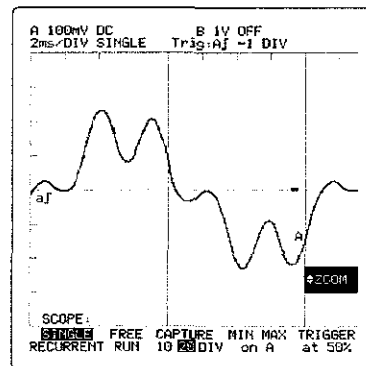

Figure 2: Distorted current waveform

2.2 Total harmonic distortion

Harmonics work together in distorting the fundamental waveform. The representation of the harmonic current with respect to the fundamental waveform is called total harmonic distortion (THD).

Total harmonic distortion (THD) is use as the harmonic index to study the effect of these non-linear loads. It considers the contribution of every individual harmonic component on the signal. A commonly cited value of 5% is often use as a dividing line between a high and low distortion level [9].

The THD of a waveform is calculated by taking the square root of the addition of the squares of the harmonic currents, and dividing them by the fundamental current. As a formula:

$$I_{\text{THD}} = \frac{\sqrt{(I_3^2 + I_5^2 + I_7^2 + I_9^2 + \dots)}}{I_1} \quad (1)$$

Where $I_1, I_3, I_5, I_7, I_9 \dots$ are the currents at their respective harmonics.

Linear loads have very low values of THD because they have little to no harmonic current. Non-linear loads have large values of THD, and cause considerable distortion to the normal sine wave.

2.3 Low voltage networks

A low voltage network usually have a voltage level less than 1000 volts or 1 kV and consists of three phase four wire system. The phase is referred to red, yellow and blue phase while the four wires consist of the three phase wire plus one neutral wire.

The low voltage networks have neutral point solidly earthed mixture of overhead lines, underground cables and aerial insulated cables [10]. In low voltage network, it has three types of supply voltage option. The supply voltage options are:

- Single-phase, two-wire, 240V, up to 12 kVA maximum demand
- Three-phase, four-wire, 415V, up to 45 kVA maximum demand
- Three-phase, four-wire, C.T. metered, 415V, up to 1,000 kVA maximum demand

2.4 Non-linear load

Most of the electronic equipment requires dc voltage to operate. The ac power supply need to convert to dc voltage via the rectifier and capacitors that within the equipment. Today electronics device mostly come together with the switched electronic device. As the capacitors charge and discharge during this conversion, the capacitor draws current in pulses, not at a continuous rate as explain in details in [11]. This irregular current demand, distorts the linear sine wave. As a result, these types of loads are commonly referred to as non-sinusoidal or non-linear loads.

2.5 Salient pole synchronous generator

Synchronous generator also produced triplen harmonics depending on its winding design in terms of pitch factor, distribution factor and slot skew. Salient pole shape and concentrated field winding of synchronous generator have caused third harmonic voltage at no-load.

Salient pole shape and concentrated field winding, direct-axis armature reactance and quadrature-axis armature reactance contribute to third harmonic voltage at balanced load. Resultant of addition the effect of backward field mmf to salient pole shape and concentrated field winding, direct-axis armature reactance and quadrature-axis armature reactance yield third harmonic voltage at unbalanced load [12].

Triplen harmonics currents are continuously flow through neutral earthing resistor (NER) that cause high temperature for generator. The high NER temperature is caused by increase in triplen harmonics currents that flow through it [13].

CHAPTER 3 METHODOLOGY

3.1 Procedure identification

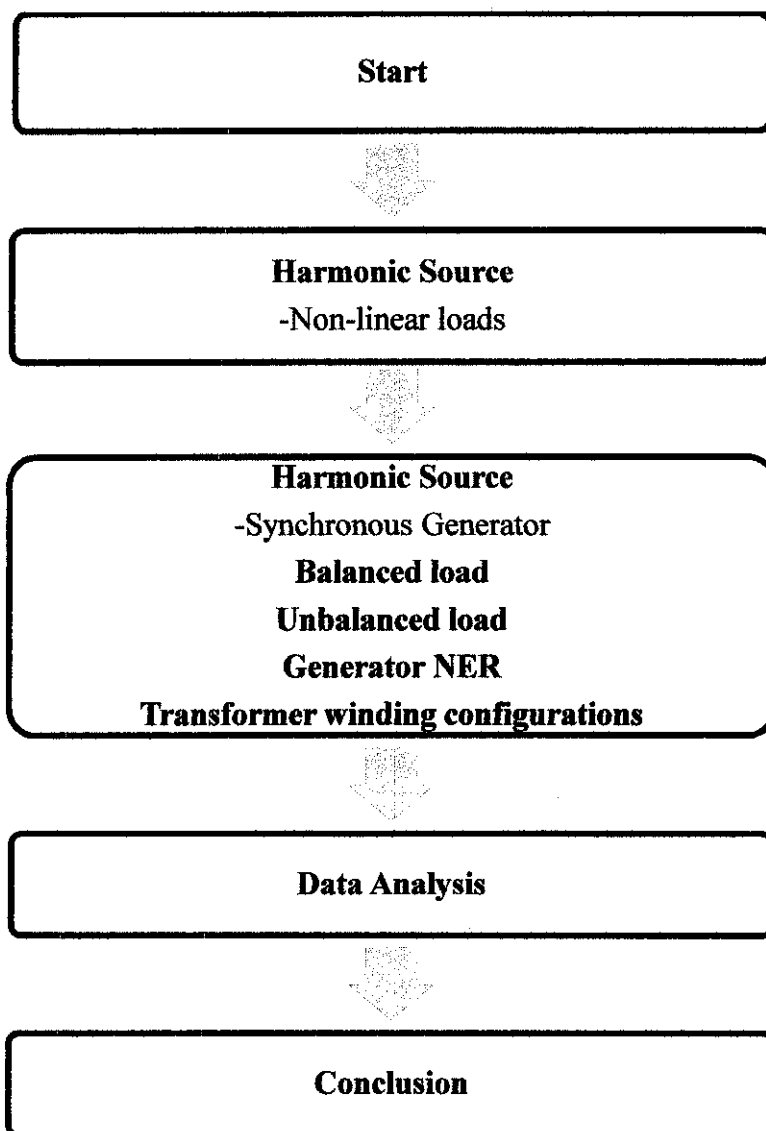

Figure 3: Work Flow chart

3.2 Research methodology

Triplen harmonics voltages are present at the output terminals of generator even when connected to a load. However, triplen harmonics currents only exist when generator begin to supply a load.

The focus for this project is to study the characteristic of the triplen harmonics and parameters that influent the triplen harmonics in the low voltage network. There are many factors that influenced triplen harmonics currents produced by generator as simulated in [14].

In order to study the triplen harmonics characteristic, a low voltage generator is use for laboratory scale experiment. This project is dividing into two phases where the first phase of this project is to study the characteristics of triplen harmonic produced by non-linear loads. The second phase involves study of triplen harmonic produced by synchronous generator. Please refer to appendix A.

3.3 Project activities

3.3.1 First phase experiment

The first phase experiment of the project is on the non-linear loads as listed in Table 1. 230V, 50 Hz AC system is being supply to the loads. Harmonic spectrum and THDs for each load is record for analyzing the effect of harmonics introduced by these loads.

Table 1: Non-linear loads rating

No.	Domestic Load	Rating
1	Battery Charger	4.9V; 700mA
2	Laptop	65W
3	Printer	16V; 500mA
4	Radio	6W
5	Television	120W
6	Fan	10W

Figure 4 below show a line diagram for the measurement of the non-linear loads:

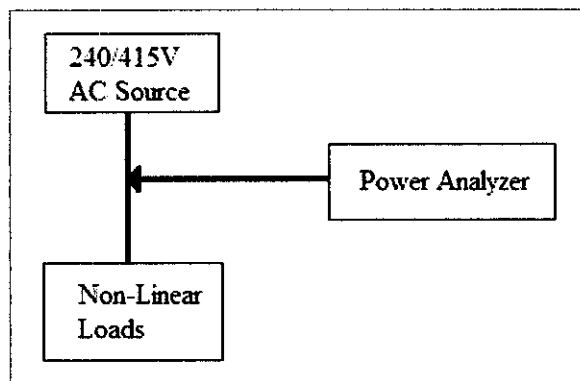

Figure 4: One line diagram indicating measuring point

3.3.2 Second phase experiment

The second phase of the project is on the triplen harmonic produced by synchronous generator for balanced, unbalanced load, generator NER and different transformer winding configurations. The 240 VAC power supply is being supply to this generator. The laboratory equipment rating for the second phase experiment is show in Table 2 below while figure 5 shows the connection in the second phase experiment.

Table 2: Laboratory equipment rating

No.	Equipment	Ratings
1	Generator	415V; 0.35A; 175W
2	Resistive load	240V; 252W
3	Inductive load	240V; 252Var
4	Capacitive load	240V; 252Var

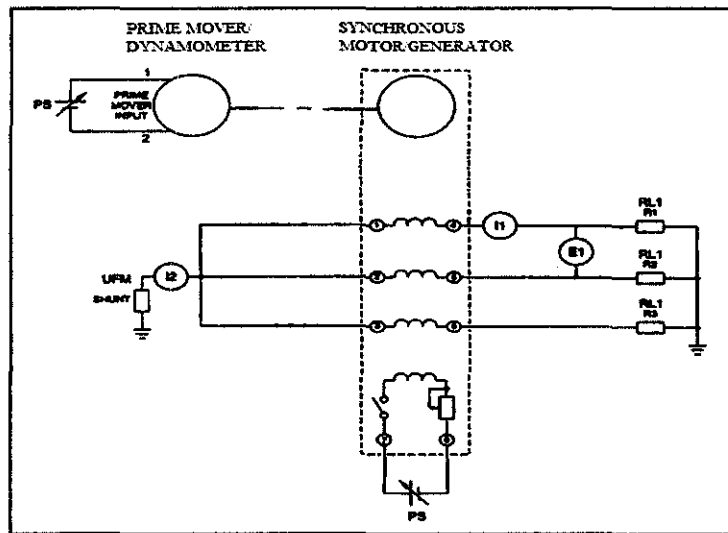

Figure 5: Diagram for 2nd phase experiment

3.3.2.1 Load Variation (Resistive/Inductive/Capacitive)

Table 3 to Table 11 shows the load value for each phase under balanced, unbalanced and their combination load impedances. The loads is in wye connection with neutral wire connected directly to the generator neutral and the harmonics current are measured at the load terminals.

Table 3: Balanced Resistive load

Case study	Phase 'a' (Ω)	Phase 'b' (Ω)	Phase 'c' (Ω)
1	686	686	686
2	800	800	800
3	1200	1200	1200
4	1600	1600	1600
5	2400	2400	2400
6	3600	3600	3600
7	4800	4800	4800
8	6000	6000	6000
9	7200	7200	7200
10	9600	9600	9600

Table 4: Balanced Inductive load

Case study	Phase 'a' (H)	Phase 'b' (H)	Phase 'c' (H)
1	2.1	2.1	2.1
2	2.5	2.5	2.5
3	3.8	3.8	3.8
4	4.3	4.3	4.3
5	5.1	5.1	5.1
6	7.6	7.6	7.6
7	10.1	10.1	10.1
8	11.4	11.4	11.4
9	15.3	15.3	15.3
10	19.1	19.1	19.1

Table 5: Balanced Capacitive load

Case study	Phase 'a' (μF)	Phase 'b' (μF)	Phase 'c' (μF)
1	0.44	0.44	0.44
2	0.53	0.53	0.53
3	0.66	0.66	0.66
4	0.89	0.89	0.89
5	1.33	1.33	1.33
6	1.99	1.99	1.99
7	2.65	2.65	2.65
8	3.31	3.31	3.31
9	3.68	3.68	3.68

Table 6: Unbalanced Resistive load

Case study	Phase 'a' (Ω)	Phase 'b' (Ω)	Phase 'c' (Ω)
1	686	800	1200
2	1600	2400	4800
3	800	1600	2400
4	1200	2400	4800
5	800	1200	1600
6	1600	2400	4800
7	686	1600	2400
8	2400	3600	4800
9	3600	4800	6000
10	6000	7200	9600

Table 7: Unbalanced Inductive load

Case study	Phase 'a' (H)	Phase 'b' (H)	Phase 'c' (H)
1	2.5	3.8	5.1
2	3.8	5.1	7.6
3	5.1	7.6	2.1
4	10.1	11.4	15.2
5	2.5	3.8	7.6
6	2.1	2.5	3.8
7	11.4	15.2	19.1
8	4.3	15.2	19.1
9	7.6	5.1	15.3
10	4.3	19.1	11.4

Table 8: Unbalanced Capacitive load

Case study	Phase 'a' (μF)	Phase 'b' (μF)	Phase 'c' (μF)
1	0.66	1.33	2.65
2	1.99	3.68	3.31
3	0.44	0.89	0.53
4	0.66	1.33	1.99
5	1.33	2.65	3.68
6	2.65	3.31	3.68
7	1.33	1.99	2.65
8	0.66	2.65	1.99

Table 9: Combination Unbalanced Resistive Inductive load

Case study	Phase 'a' ($\Omega+H$)	Phase 'b' ($\Omega+H$)	Phase 'c' ($\Omega+H$)
1	686+2.5	800+3.8	1200+5.1
2	1600+3.8	2400+5.1	4800+7.6
3	800+5.1	1600+7.6	2400+2.1
4	1200+2.5	2400+3.8	4800+5.1
5	800+2.5	1200+3.8	1600+7.6
6	1600+2.1	2400+2.5	4800+3.8
7	686+11.4	1600+15.2	2400+19.1
8	2400+4.3	1200+11.4	4800+10.1
9	3600+7.6	4800+3.8	6000+15.3
10	6000+2.1	7200+7.6	9600+3.8

Table 10: Combination Unbalanced Resistive Inductive and Capacitive load

Case study	Phase 'a' ($\Omega+H+\mu F$)	Phase 'b' ($\Omega+H+\mu F$)	Phase 'c' ($\Omega+H+\mu F$)
1	686+2.5+0.44	800+3.8+0.53	1200+5.1+0.89
2	1600+3.8+0.44	2400+5.1+0.53	4800+7.6+0.89
3	800+5.1+0.44	1600+7.6+0.53	2400+2.1+0.89
4	1200+2.5+0.44	2400+3.8+0.53	4800+5.1+0.89
5	800+2.5+0.44	1200+3.8+0.53	1600+7.6+0.89
6	1600+2.1+0.44	2400+2.5+0.53	4800+3.8+0.89
7	686+11.4+0.44	1600+15.2+0.53	2400+19.1+0.89
8	2400+4.3+0.44	1200+11.4+0.53	4800+10.1+0.89
9	3600+7.6+0.44	4800+3.8+0.53	6000+15.3+0.89
10	6000+2.1+0.44	7200+7.6+0.53	9600+3.8+0.89

Table 11: Generator NER

Case study	Phase 'a' (Ω)	Phase 'b' (Ω)	Phase 'c' (Ω)
1	0	0	0
2	80	80	80
3	120	120	120
4	160	160	160
5	240	240	240
6	480	480	480
7	960	960	960

3.3.2.2 Generator Neutral Earth Resistor (NER)

The NER value for the generator is varied and is connect with the balanced resistive load. Loads are connecting in wye with neutral wire connected to generator neutral. The harmonics currents are measure at the generator terminals. The generator NER value is varying from 0 ohm to 960 ohm.

3.3.2.3 Transformer winding configurations

The connection of the transformers is use with four different winding configurations, which are delta-delta, delta-wye, wye-delta and wye-wye. The primary winding of the transformer is connecting to the terminal voltage of the generator and the step-down secondary winding is directly connecting to balanced resistive load. Loads are connecting in wye with neutral wire connected to the wye transformer winding (where applicable) and generator neutral points.

CHAPTER 4

RESULTS AND DISCUSSIONS

4.1 Non-linear load

Figure 6 shows the third harmonic current produce at neutral conductor for each non-linear load. This figure shows that television contains highest third harmonic neutral current (199.62 mA) follows with laptop (77.14 mA), radio (17.21 mA), printer (15.46 mA), battery charger (15.37 mA) and finally fan (3 mA).

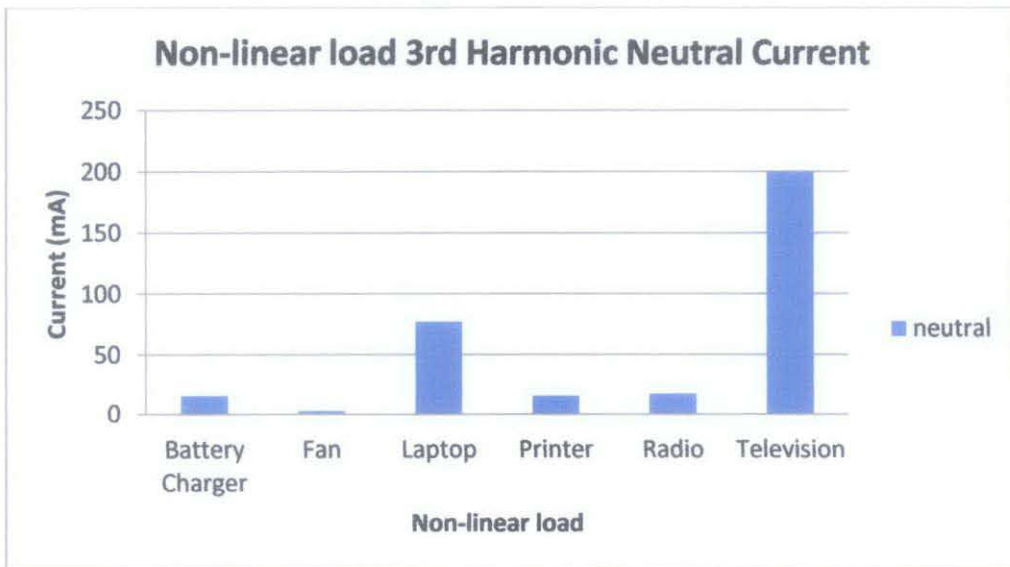

Figure 6: Third Harmonic Current vs. nonlinear load

Figure 7 to Figure 18 shows the current harmonic waveform and spectrum for respective domestic non-linear load. The voltage waveform in each domestic non-linear load still in sinusoidal waveform but produce the distorted current waveforms in all domestic loads.

4.1.1 Battery Charger

Figure 7 show that the current waveform is distorted while the voltage waveform is remaining in sinusoidal waveform. The current is 292.8 mA while voltage is 246.6V.

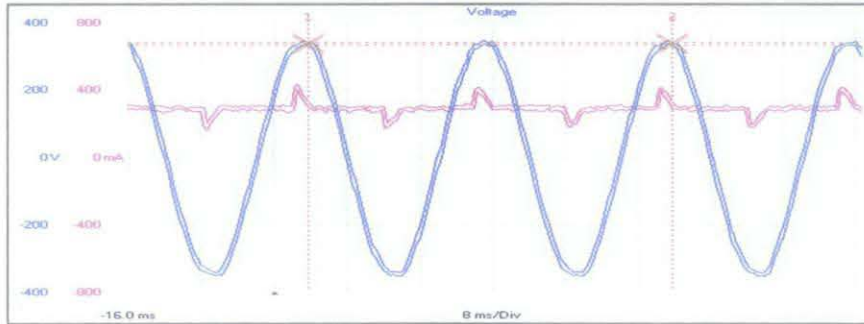

Figure 7: Battery Charger Voltage and Current waveform

Figure 8 show the triplen harmonic spectrum for battery charger from fundamental to fifty first order harmonics. As the order of triplen harmonic is increase the current become lower.

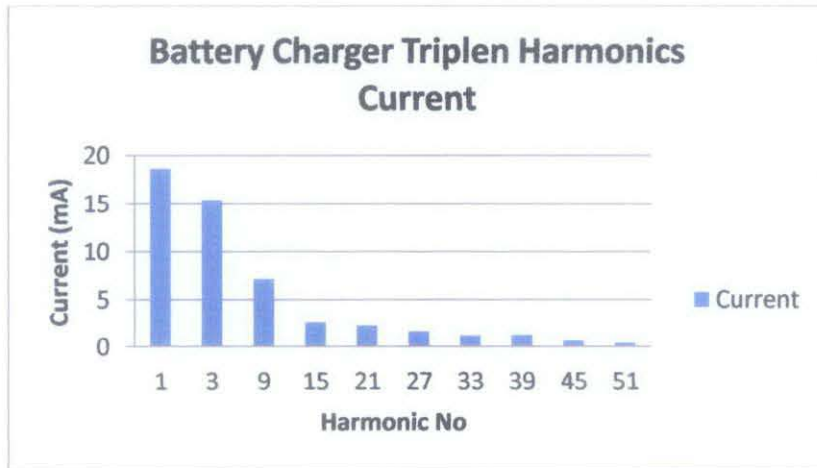

Figure 8: Battery charger triplen harmonics current

4.1.2 Laptop

Figure 9 show that the current waveform is distorted while the voltage waveform is remaining in sinusoidal waveform. The current is 489 mA while voltage is 255.2 V.

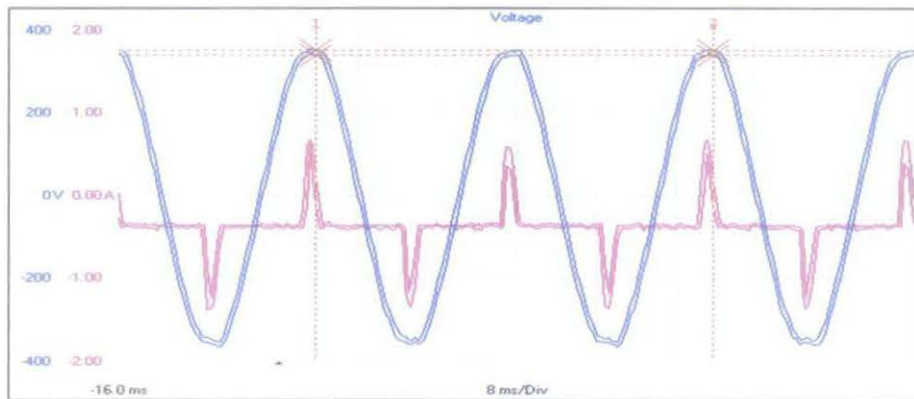

Figure 9: Laptop Voltage and Current waveform

Figure 10 show the triplen harmonic spectrum for laptop from fundamental to fifty first order harmonics. As the order of triplen harmonic is increase the current become lower.

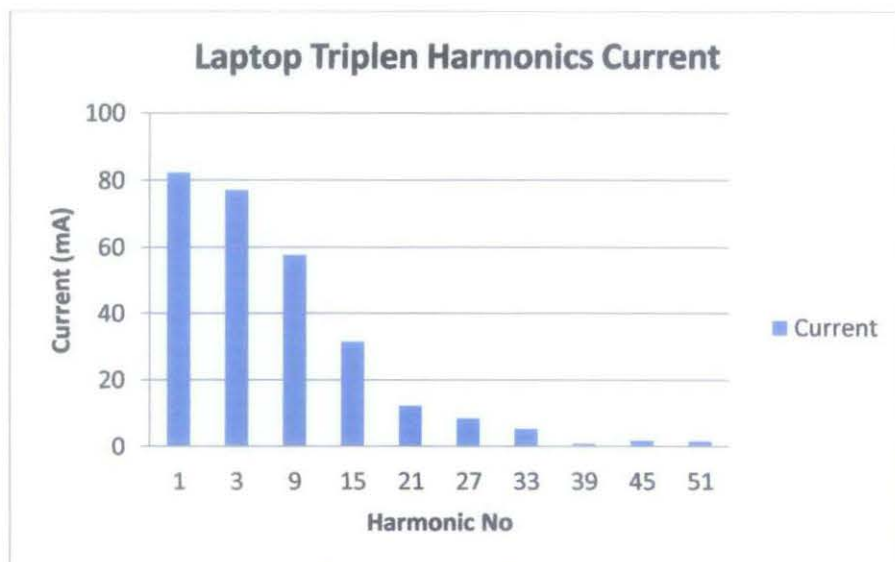

Figure 10: Laptop triplen harmonics current

4.1.3 Printer

Figure 11 show that the current waveform is distorted while the voltage waveform is remaining in sinusoidal waveform. The current is 244.9 mA while voltage is 251.6 V.

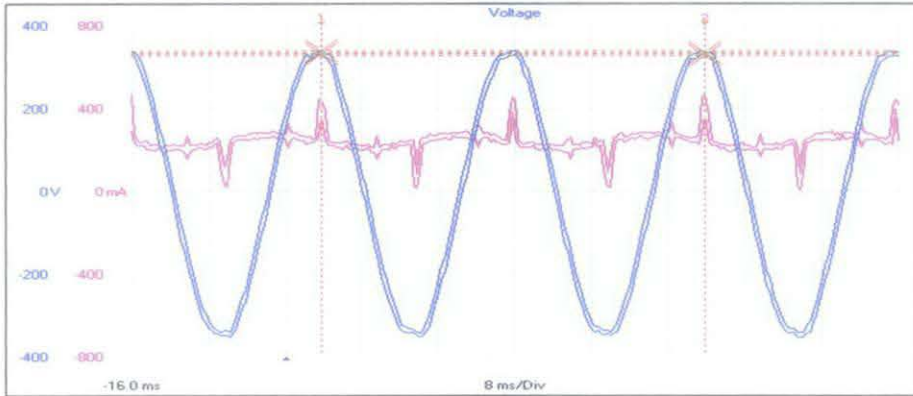

Figure 11: Printer Voltage and Current waveform

Figure 12 show the triplen harmonic spectrum for printer from fundamental to fifty first order harmonics. As the order of triplen harmonic is increase the current become lower.

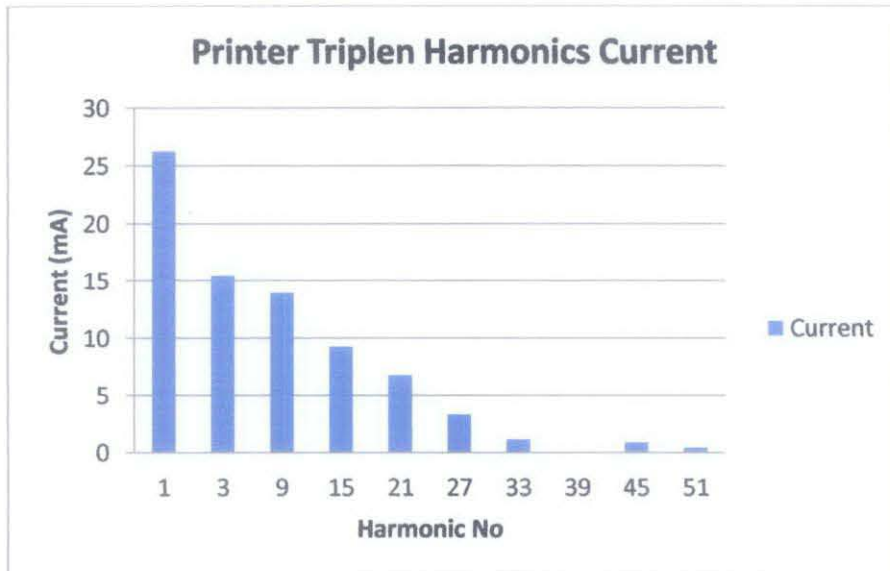

Figure 12: Printer triplen harmonics current

4.1.4 Radio

Figure 13 show that the current waveform is distorted while the voltage waveform is remaining in sinusoidal waveform. The current is 245.4 mA while voltage is 246.1 V.

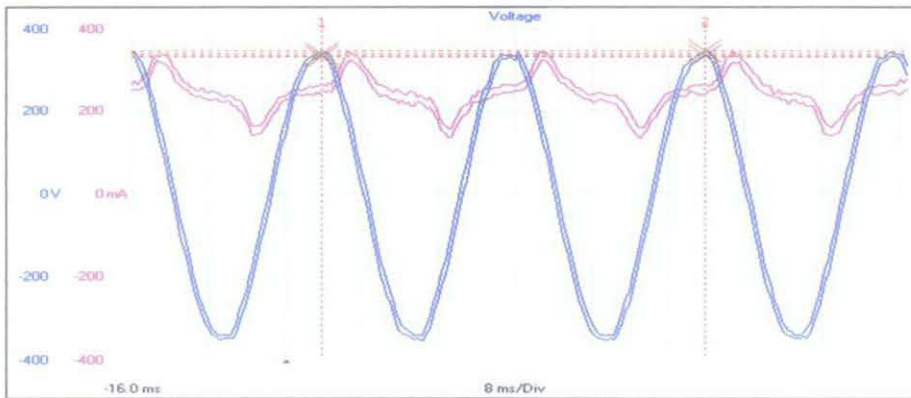

Figure 13: Radio Voltage and Current waveform

Figure 14 show the triplen harmonic spectrum for radio from fundamental to fifty first order harmonics. The fundamental and third order produces more than 15 mA current while the remaining order harmonics produce very small current.

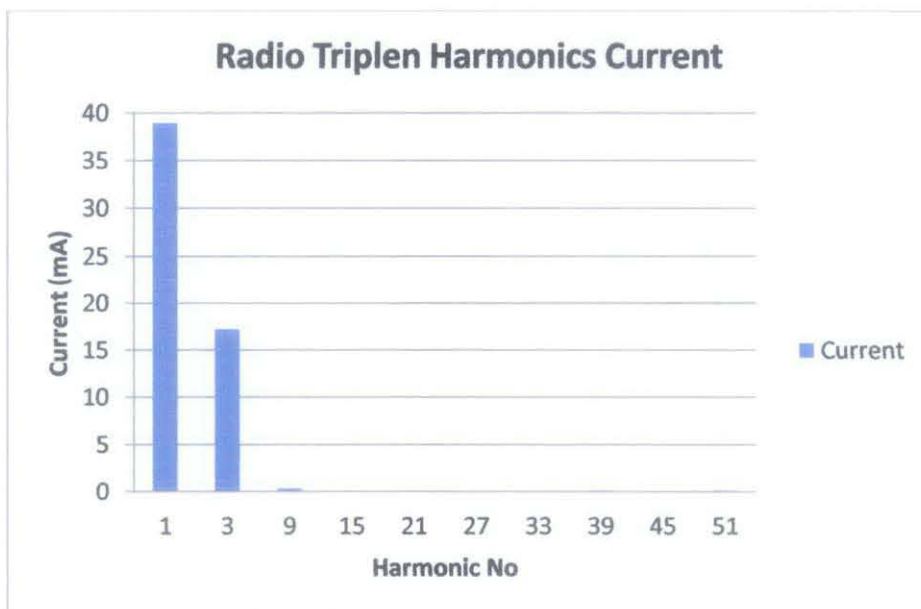

Figure 14: Radio triplen harmonics current

4.1.5 Television

Figure 15 show that the current waveform is distorted while the voltage waveform is remaining in sinusoidal waveform. The current is 1 A while voltage is 354 V.

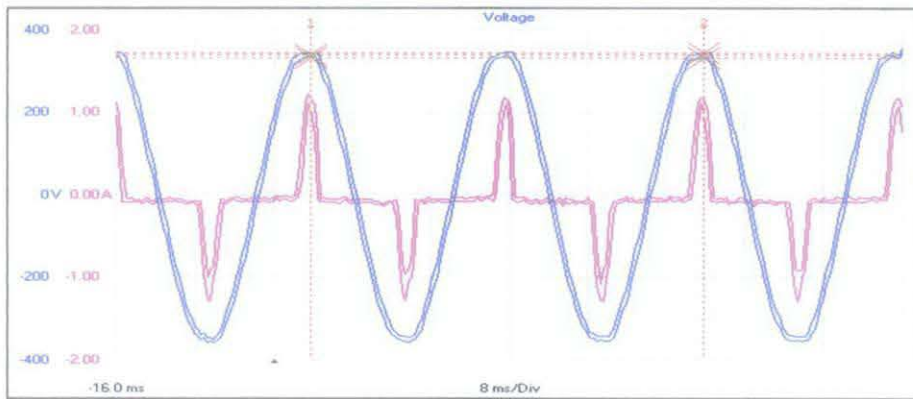

Figure 15: Television Voltage and Current waveform

Figure 16 show the triplen harmonic spectrum for television from fundamental to fifty first order harmonics. As the order of triplen harmonic is increase the current become lower.

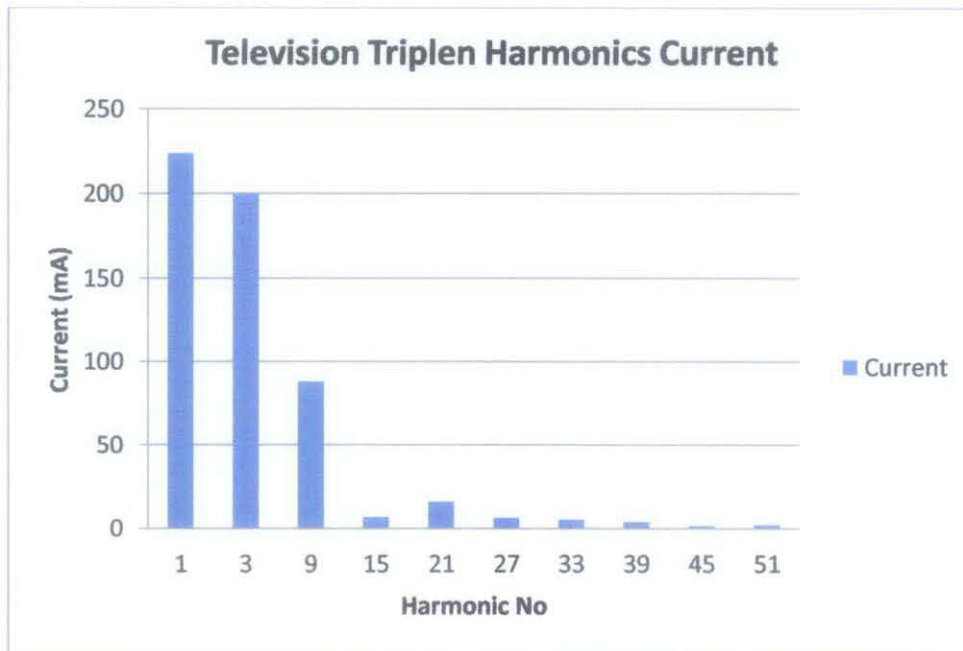

Figure 16: Television triplen harmonics current

4.1.6 Fan

Figure 17 show that the current waveform is distorted while the voltage waveform is remaining in sinusoidal waveform. The current is 229.7 mA while voltage is 251.5 V.

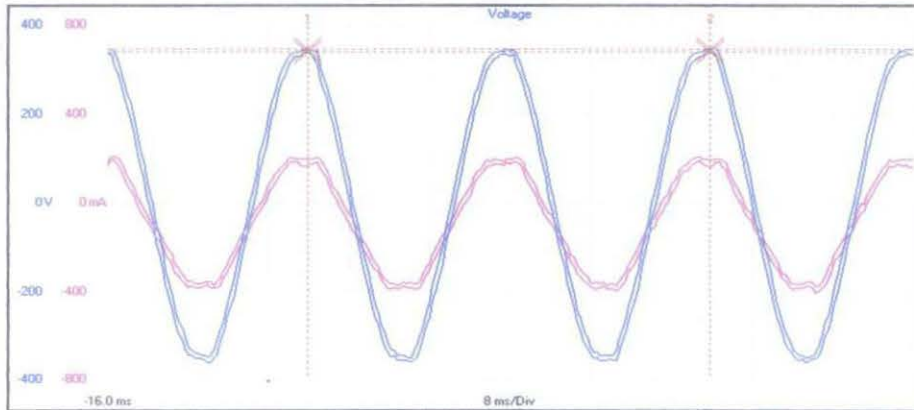

Figure 17: Fan Voltage and Current waveform

Figure 18 show the triplen harmonic spectrum for fan from fundamental to fifty first order harmonics. The fundamental produce more than 200 mA while the third order is very small.

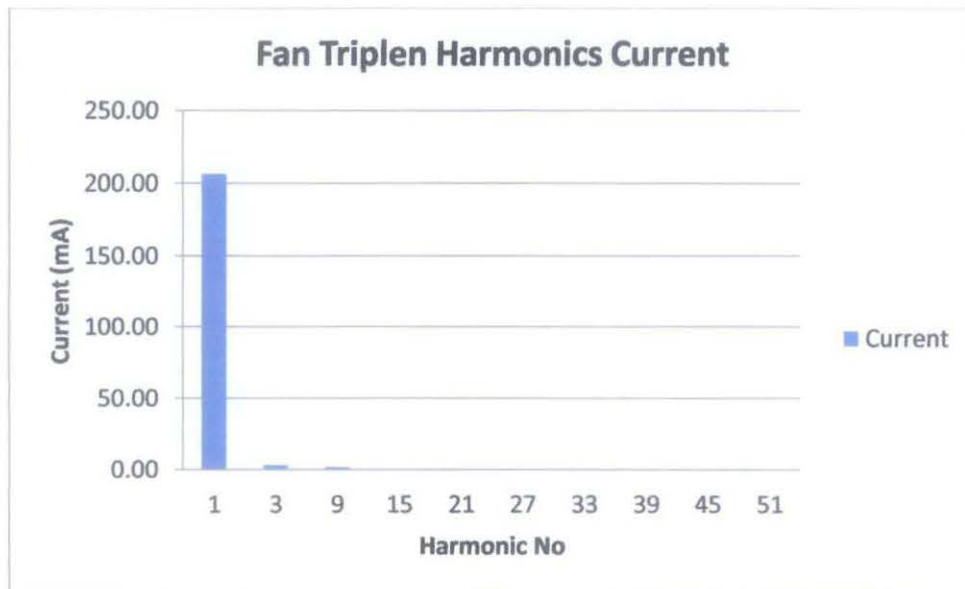

Figure 18: Fan triplen harmonics current

4.2 Synchronous Generator

The third harmonic current for balanced resistive, inductive, capacitive, combination of resistive and inductive and combination of resistive, inductive and capacitive load are show in Figure 19 to Figure 23, correspondingly.

4.2.1 Load variation

4.2.1.1 Balanced load

4.2.1.1.1 Balanced Resistive load

Figure 19 show the third harmonic current versus balanced resistive load. Under balanced load condition, the magnitude of current in each phase is almost same. The phase and neutral third harmonic currents are inversely proportional to balanced resistive.

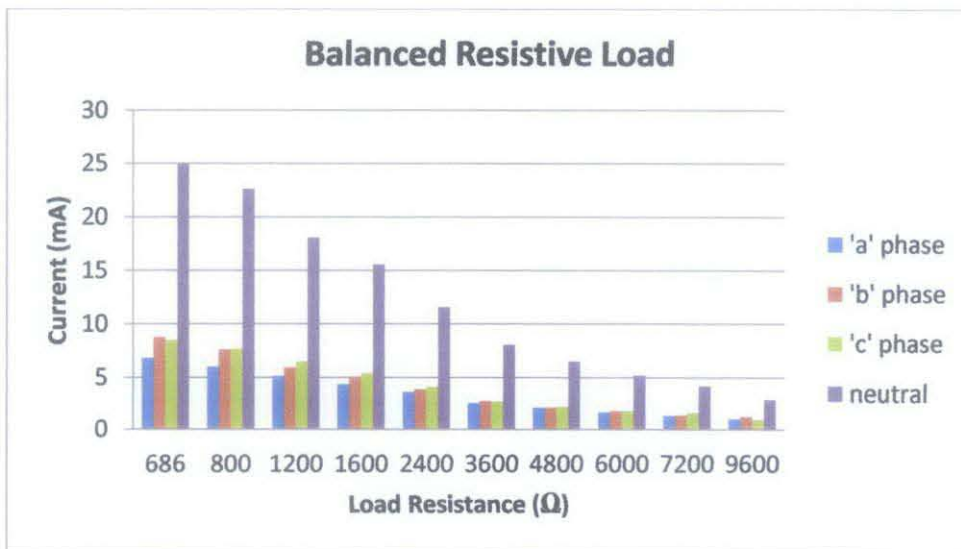

Figure 19: Third harmonic current vs. balanced resistive load

4.2.1.1.2 Balanced Inductive load

Figure 20 show the third harmonic current versus balanced inductive load. The neutral third harmonic currents are inversely proportional to balanced inductive load. The magnitude of current in each phase is same.

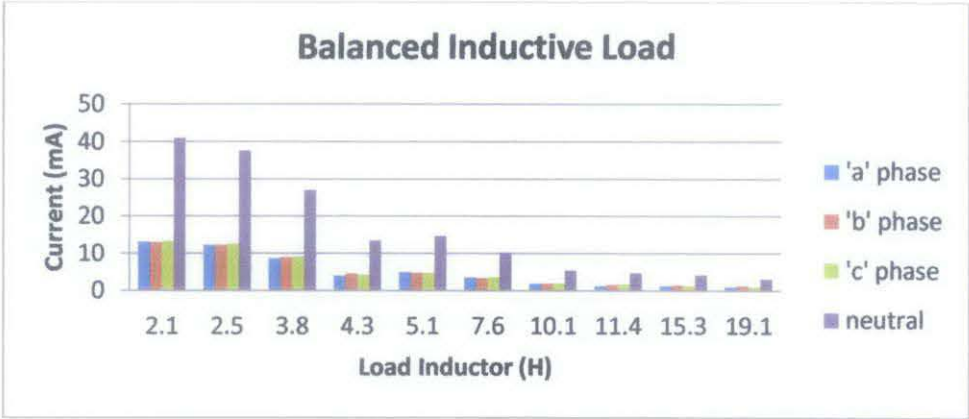

Figure 20: Third harmonic current vs. balanced inductive load

4.2.1.1.3 Balanced Capacitive load

Figure 21 show the third harmonic current versus balanced capacitive load. Under balanced load condition, the magnitude of current in each phase is same. The phase and neutral third harmonic currents are proportional to balanced capacitive. The neutral third harmonic currents produce is much higher if compare with the balanced resistive and inductive loads.

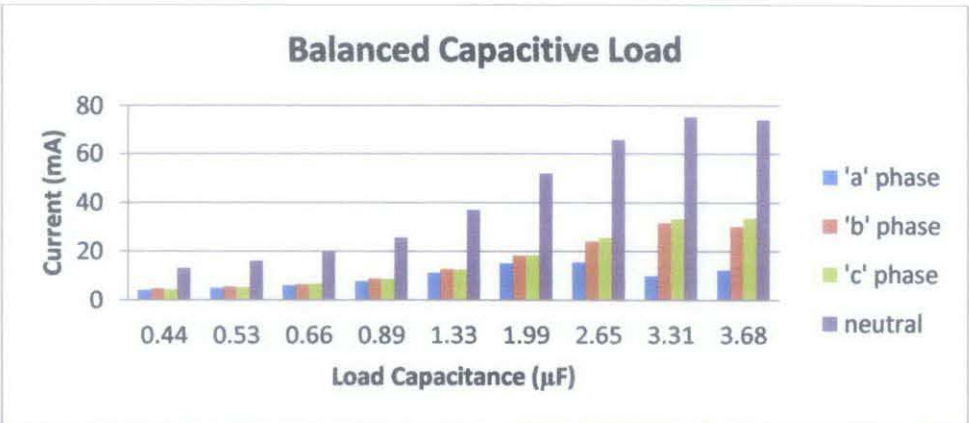

Figure 21: Third harmonic current vs. balanced capacitive load

4.2.1.1.4 Balanced Resistive and Inductive load

Figure 22 show the third harmonic current versus balanced resistive plus inductive load. The first five experiment show that the neutral third harmonic currents are inversely proportional to the loads. Start at the six experiment until ten experiment, the neutral third harmonic currents start to increase and decrease slowly. This is probably due to value of impedance in six experiment is slightly higher than in seven experiment.

The magnitude of the phase current in each phase is same for the ten experiments.

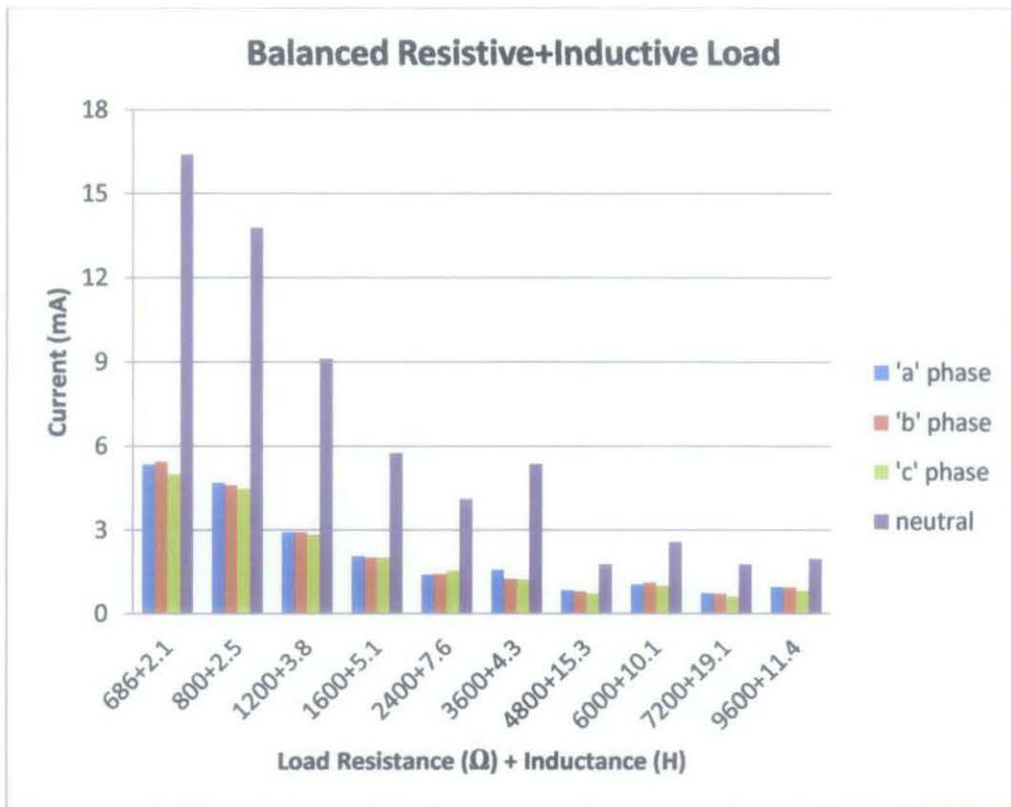

Figure 22: Third harmonic current vs. balanced resistive + inductive load

4.2.1.1.5 Balanced Resistive, Inductive and Capacitive load

Results from the combination of the balanced resistive, Inductive and capacitive load is shown in Figure 23. Generally, this combination shows that the neutral third harmonic currents are inversely proportional to the load.

The first six experiments shows the third harmonic currents are inversely proportional to the loads. The seven experiments have high neutral third harmonics current than six experiments due to the total value of impedance in the seven experiments are higher than six experiments.

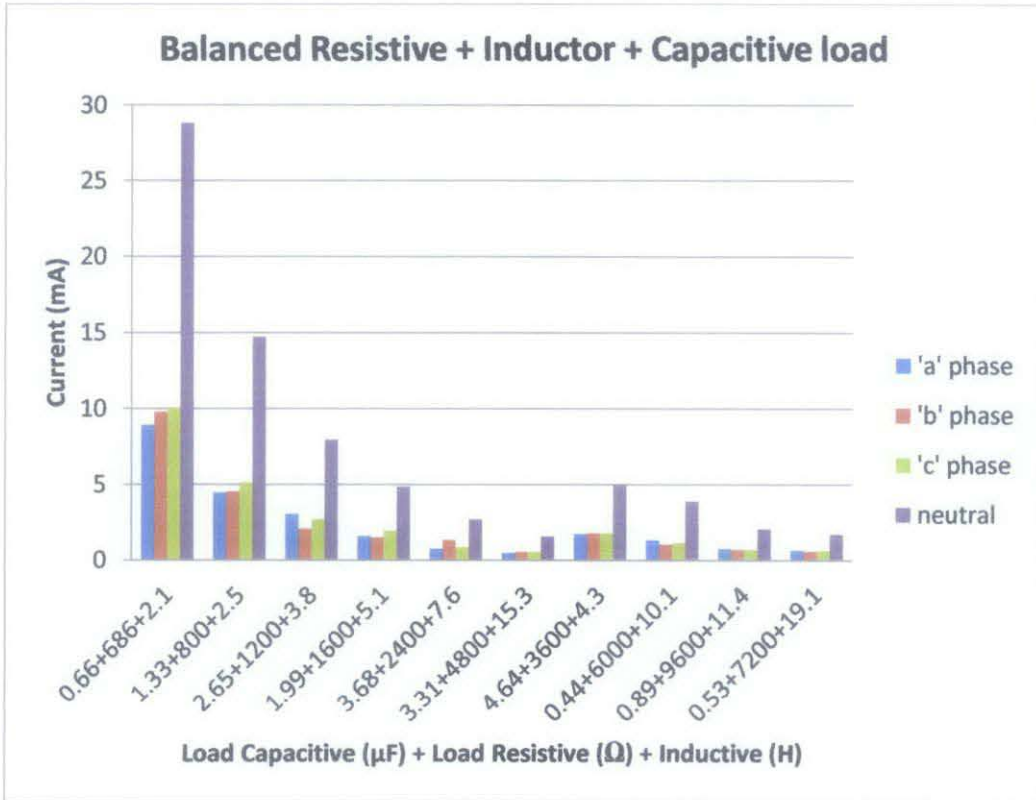

Figure 23: Third harmonic current vs. balanced resistive + Inductive + capacitive load

The third harmonic current for unbalanced resistive, inductive, capacitive, combination of resistive and inductive and combination of resistive, inductive and capacitive load are show in Figure 24 to Figure 28, correspondingly.

4.2.1.2 Unbalanced load

In Figure 24 to Figure 28 below, the current magnitudes in each phase in the unbalanced load condition are different. This is due to the load in each phase is connected in different value thus cause the system become unbalanced. In unbalanced condition, the third harmonic current phase angle is different with each other. The result from this different phase angle, cause the third harmonic current in the neutral is slightly lower than the arithmetic sum of all phase currents.

4.2.1.2.1 Unbalanced Resistive load

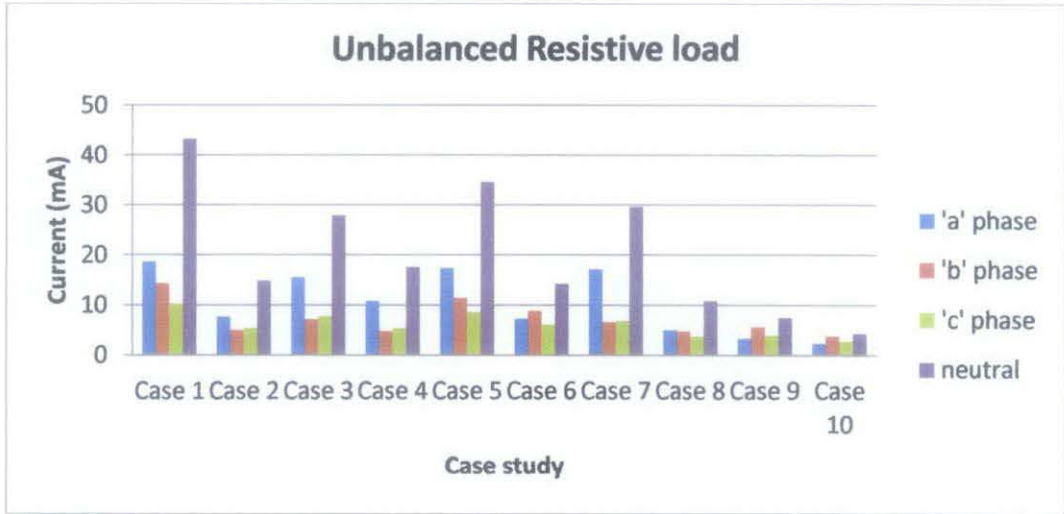

Figure 24: Third harmonic current vs. unbalanced resistive load

4.2.1.2.2 Unbalanced Inductive load

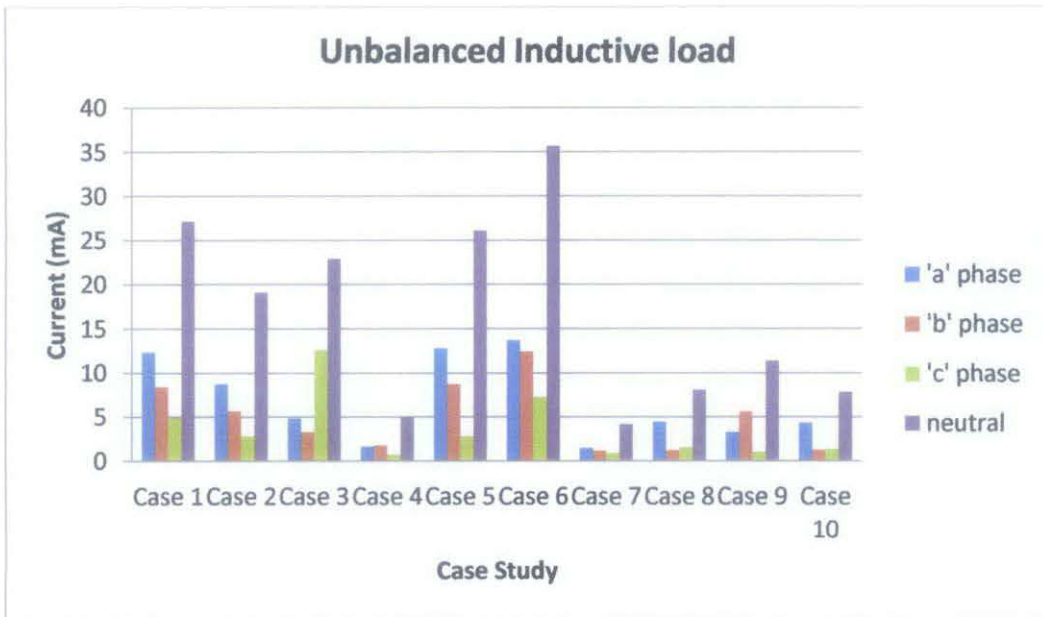

Figure 25: Third harmonic current vs. unbalanced inductive load

4.2.1.2.3 Unbalanced Capacitive load

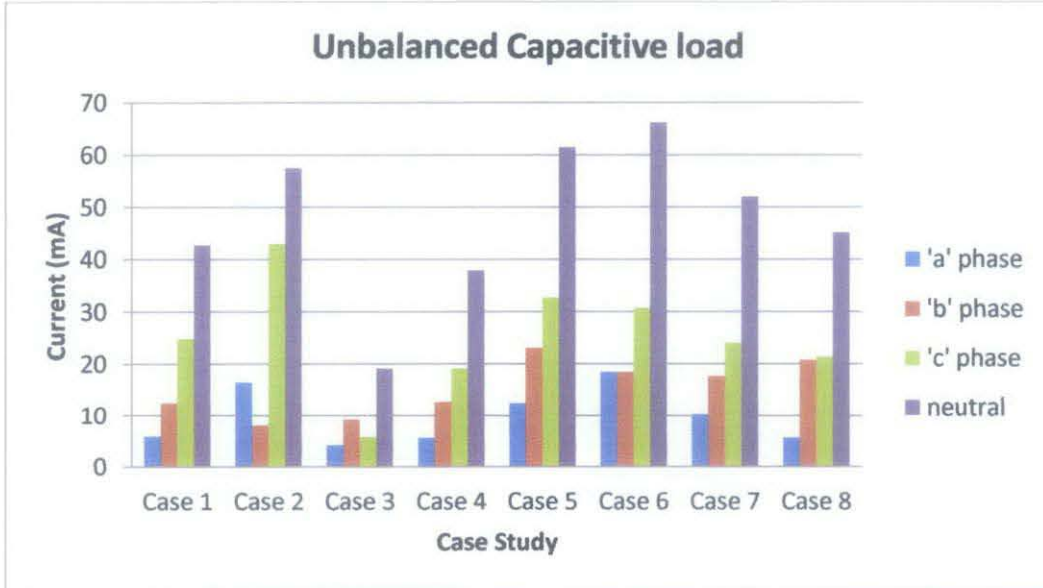

Figure 26: Third harmonic current vs. unbalanced capacitive load

4.2.1.2.4 Unbalanced Resistive and Inductive load

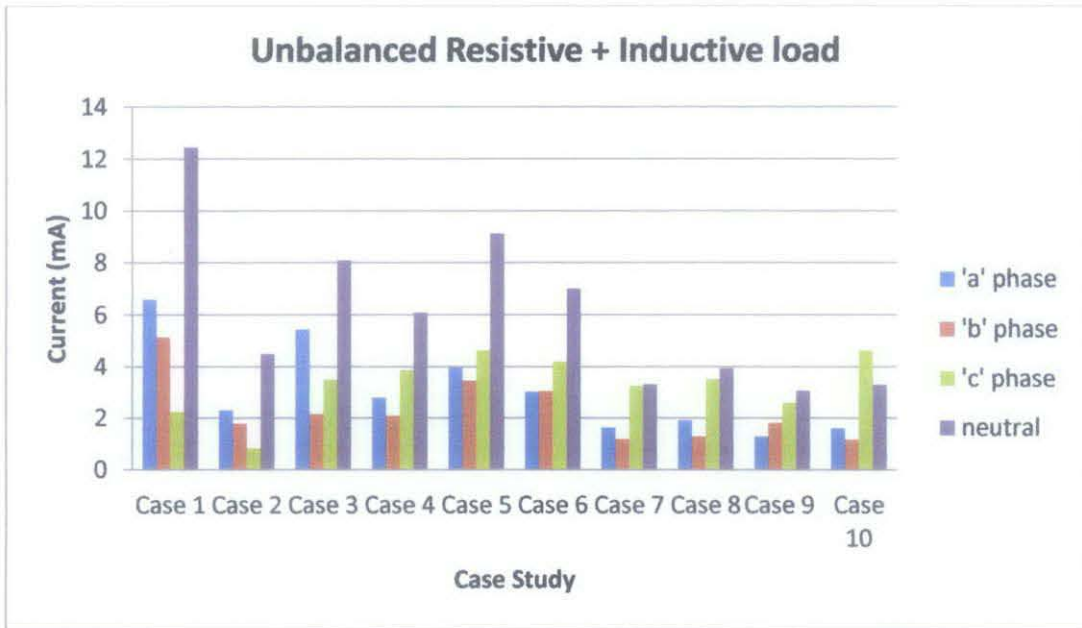

Figure 27: Third harmonic current vs. unbalanced resistive + inductive load

4.2.1.2.5 Unbalanced Resistive, Inductive and Capacitive load

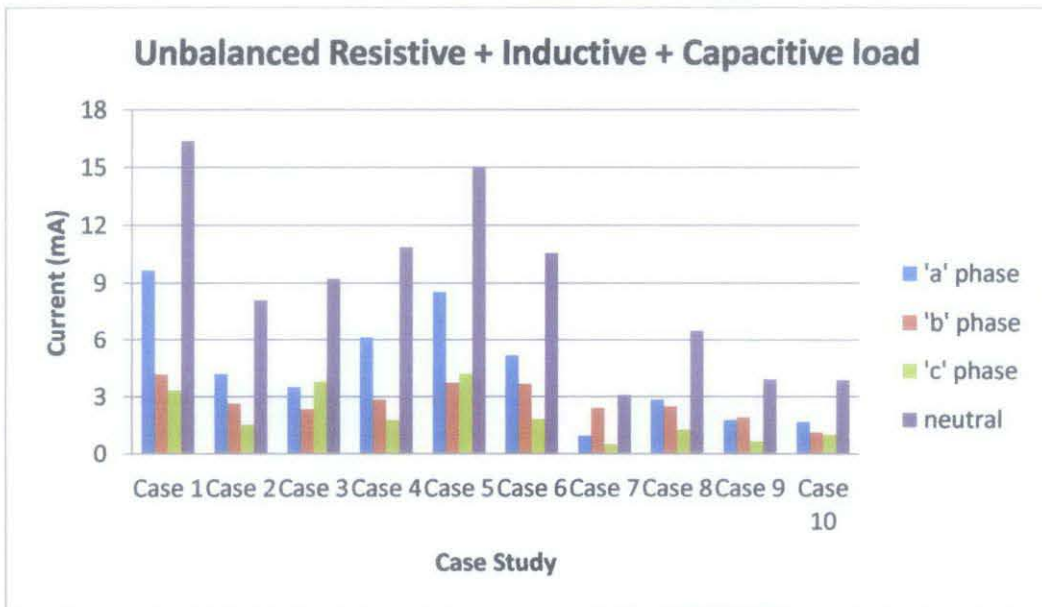

Figure 28: Third harmonic current vs. unbalanced resistive + inductive + Capacitive load

4.2.2 Generator Neutral Earth Resistor (NER)

Figure 29 show the relationship between the generator NER values and third harmonic current. The phase and neutral third harmonic currents are inversely proportional to the generator NER value. On average the reduction are 32% against 100% increase in NER resistance for the phase and neutral third harmonic currents.

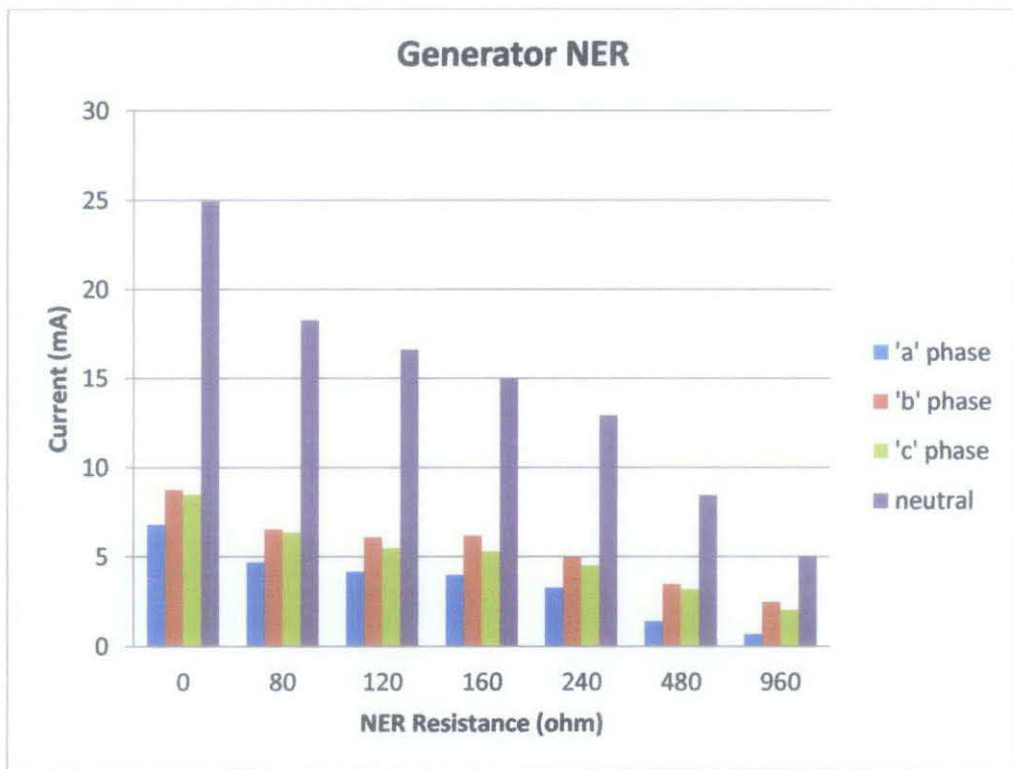

Figure 29: Third harmonic current vs. generator NER value

4.2.3 Transformer Winding configurations

Figure 30 to Figure 33 shows the phase and neutral third harmonic currents at the generator terminal, primary winding, secondary winding and load end for four different winding configurations.

4.2.3.1 Delta-Delta Transformer Configuration

Figure 30 show the third harmonic current for delta-delta transformer configuration. In delta-delta transformer configuration, the circulating third harmonic current in the delta primary is lower than the circulating third harmonic currents in the delta secondary. No third harmonic current flows in the load because the current circulates in the delta primary and secondary windings.

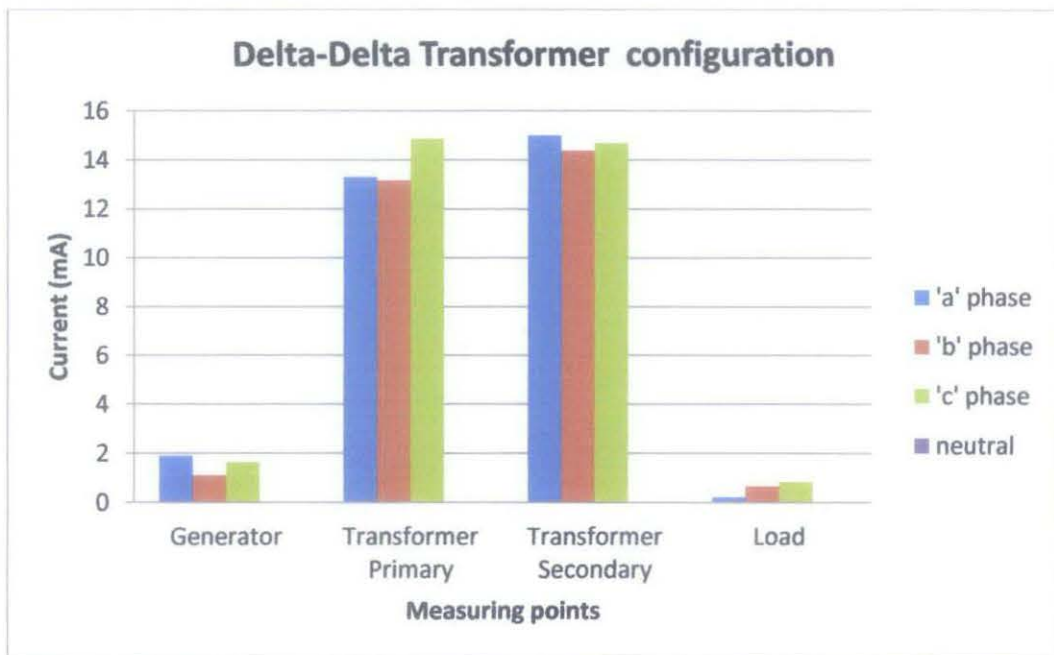

Figure 30: Third harmonic current for delta-delta transformer configuration

4.2.3.2 Delta-Wye Transformer Configuration

Figure 31 show the third harmonic current for delta-wye transformer configuration. There is almost no third harmonic currents flow in the transformers secondary winding and in the loads. This is because the third harmonic currents are being trap in the delta primary windings it just circulates in there.

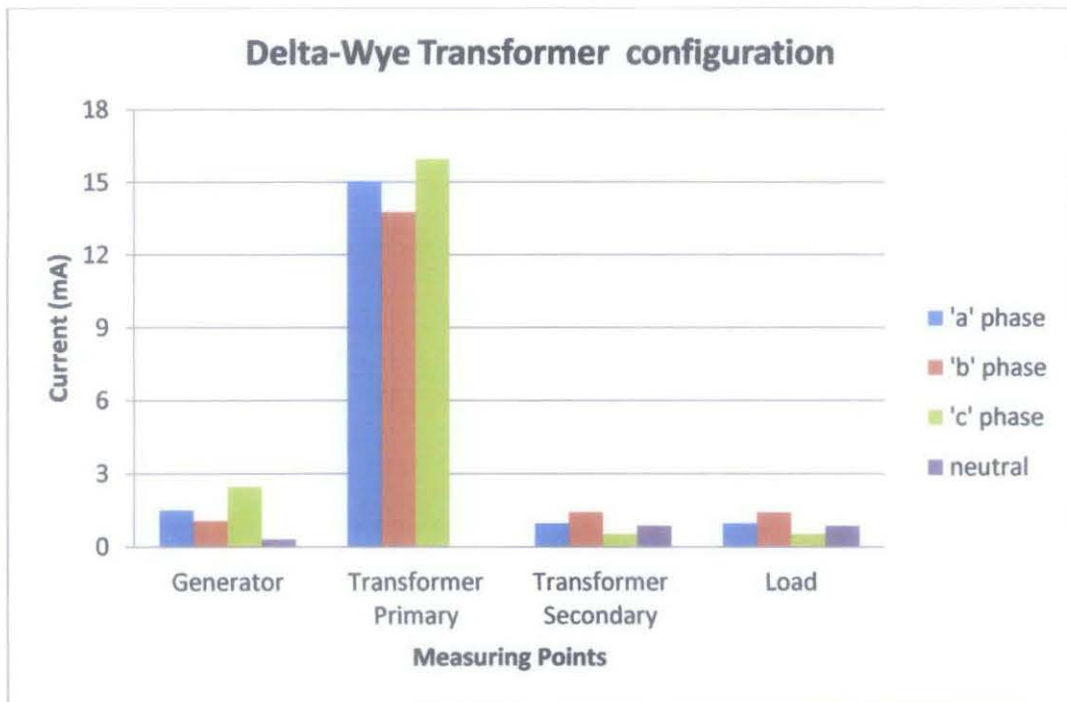

Figure 31: Third harmonic current for delta-wye transformer configuration

4.2.3.3 Wye-Delta Transformer Configuration

Figure 32 show the wye-delta transformer winding configuration. Since wye primary windings provide the lowest zero sequence impedance to the neutral, in wye-delta transformer configuration it produce the highest phase and neutral third harmonic currents. The current is about 80 mA in each phase while the neutral current is 237.85 mA. There is no third harmonic currents circulate in the secondary winding.

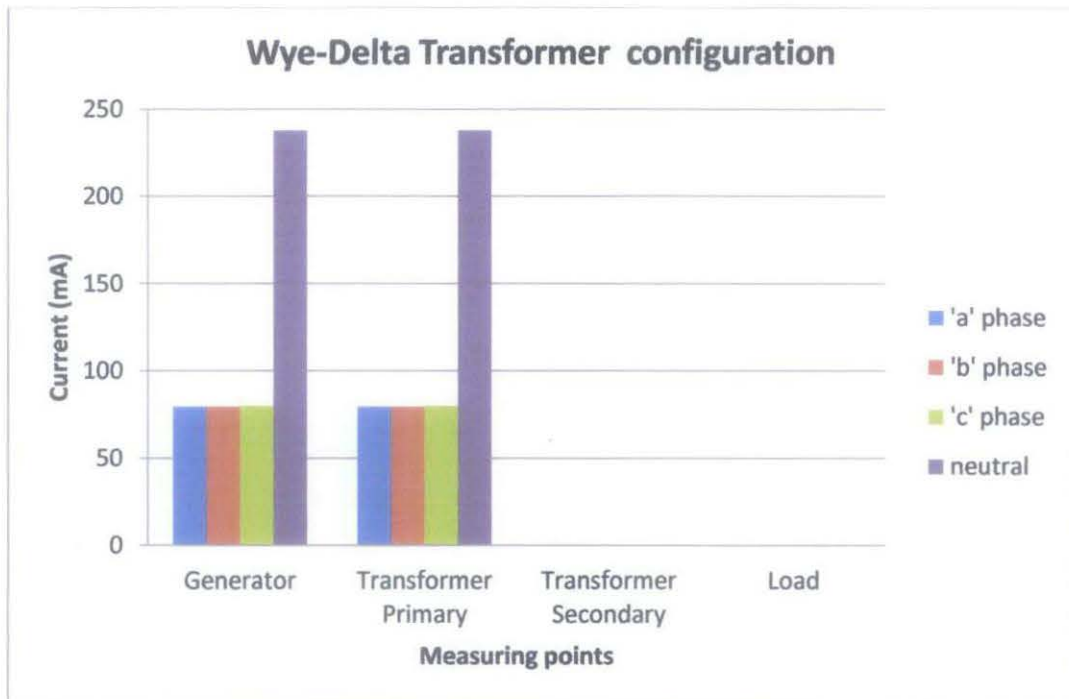

Figure 32: Third harmonic current for wye-delta transformer configuration

4.2.3.4 Wye-Wye Transformer Configuration

In wye-wye transformer configuration as shown in Figure 33 below, the third harmonic currents flow through the transformer windings and it contain high neutral third harmonic current in the secondary transformer winding (23.77 mA) and in the end load (23.77 mA) as this transformer type of configuration provide the lowest zero impedance that allowed the neutral current to flow at the neutral conductor.

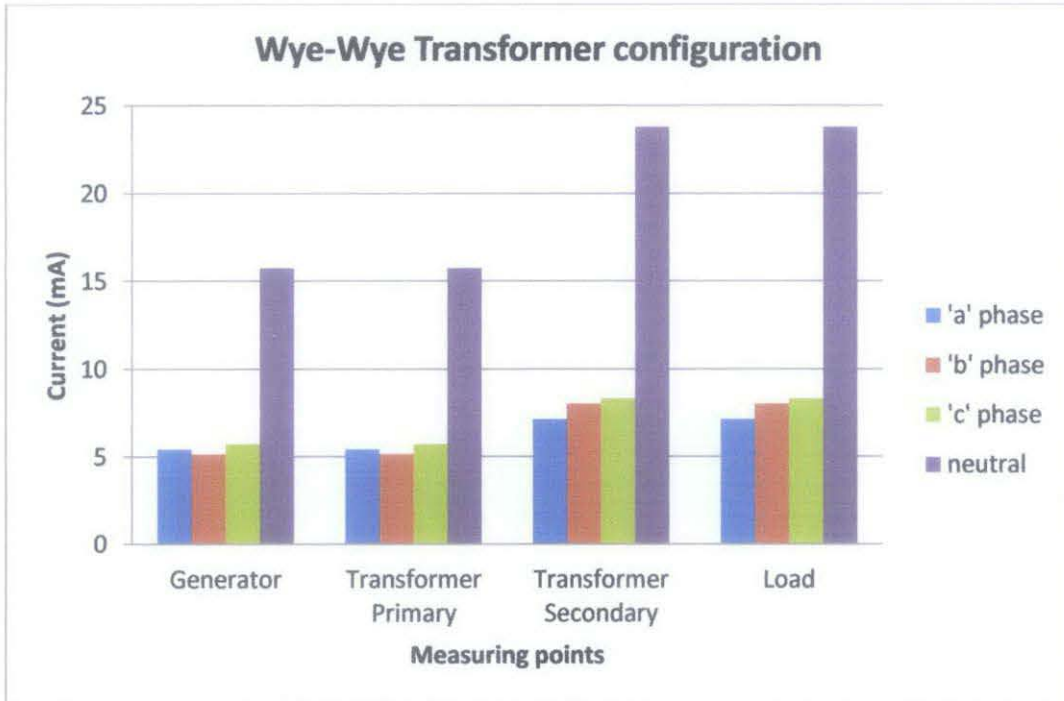

Figure 33: Third harmonic current for wye-wye transformer configuration

CHAPTER 5

CONCLUSIONS AND RECOMMENDATION

5.1 Conclusions

Non-linear load such as television and laptop produce triplen harmonics. The non-linear loads with higher technology produce highest third harmonic currents.

The load impedance such as resistive, inductive and capacitive, generator NER values and transformer winding configurations influences third harmonic currents.

Highest load impedance can reduce the magnitude of the neutral third harmonic currents while the unbalanced load can cause the system become unbalanced thus produce different current magnitude and phase angle in each phase.

The existing of generator NER helps to reduce the magnitude of triplen harmonic currents in the system. Triplen harmonic currents are zero sequence in balanced load condition.

Zero sequence networks would determine the triplen harmonic currents flow in different transformer winding configurations. Third harmonics currents do not flow through wye-delta transformers and the amount that flows depends on the phase angle and magnitude of the currents in each of the three phases.

5.2 Recommendation

The outcome of this project can be used to further research on method to reduce the triplen harmonic currents flowing in the network. The research to reduce the triplen harmonics can be conducted in terms of using the characteristics of triplen harmonics in balanced load, the existing of generator NER and also the transformers winding configuration.

Special attention must be given to address unbalanced triplen harmonics currents due to unbalanced network impedance. This is due to in unbalanced load, the triplen harmonics in neutral conductor can't be estimate.

REFERENCES

- [1] Francisco C. De La Rosa. "Harmonics and Power Systems", Taylor & Francais, pp. 1-2
- [2] Najwa M., C. M. Hadzer and Syafrudin M. (2004). "Application of LC Filter in Harmonics Reduction". Kuala Lumpur, Malaysia.
- [3] C.Venkatesh and D. Srikanth. (2008)." Modelling of non-linear loads and estimation of harmonics in Industrial Distribution System". Fifteenth National Power Systems Conference (NPSC), IIT Bombay
- [4] S. Ashok, "Effect of power system harmonics on power system equipment and loads", R.E.C, Calicut.
- [5] Task Force on harmonics modeling and simulation, IEEE PES Harmonic Working Group, "Characteristics and modeling of Harmonic Sources-Power Electronics Devices," *IEEE Tran. Power Delivery*, Vol. 16, No. 4, Oct. 2001, pp. 791-800.
- [6] H. Stephenson, "Application Notes - Harmonics", Ukhama2, March, 1999.
- [7] R. Arthur and R. A. Shanahan, "Neutral Currents in Three Phase Wye Systems", Square D, Oshkosh, Wisconsin, August, 1996.

- [8] Fluke Corporation (Fluke Digital Library). *Troubleshooting Power Harmonics*. [Online] <http://www.fluke.com/library>.
- [9] George J. Wakileh. "Power Systems Harmonics", 2001, pp. 137-144
- [10] "Electricity Supply Application Handbook", Tenaga National Berhad (200866-W).
- [11] G. M. William, "Understanding nonlinear loads and generator set interaction", *Caterpillar Inc.*
- [12] G. Angst and J. L. Oldenkamp, "Third-harmonic voltage generation in salient pole synchronous machines," Transactions of the American Institute of Electrical Engineers, Vol. 75, Issue: 3, pp. 434–441, June 1956
- [13] M. F. Abdullah, N. H. Hamid, Z. Baharudin, M. F. I. Khamis, N. S. R. Hashim and S. Yusof, "Investigation On High Neutral Earthing Resistor Temperature When Islanded Generator Connected To Utility Grid," The 9th International Power and Energy Conference, Oct. 2010.
- [14] M. F. Abdullah, N. H. Hamid, Z. Baharudin and M. F. I. Khamis, (in press) "Triplen Harmonics Currents Propagation Through Medium Voltage Distribution Network," Fourth International Conference on Modeling, Simulation & Applied Optimization, April, 2011.

APPENDIX

APPENDIX A

Gantt chart

No.	Detail/ Week	1	2	3	4	5	6	7		8	9	10	11	12	13	14
1	Selection of Project Title								MID SEMESTER BREAK							
2	Preliminary Research Work / Journal study															
3	Submission of Prelim Report															
4	Harmonic Source – Non-linear load															
5	Harmonic Source – Synchronous Generator															
6	Transformer Winding Configuration															
7	Submission of Progress Report															
8	Report/Poster/Technical Paper															
9	Submission of Final Report															

Process