

**CERTIFICATION OF APPROVAL**

**Preliminary Analysis on Dynamic Behavior of Typical School Building**

by

**Mohd Faisal bin Mohd Radzi**

**A project dissertation submitted to the  
Civil Engineering Programme  
Universiti Teknologi PETRONAS  
in partial fulfilment of the requirement for the  
BACHELOR OF ENGINEERING (Hons)  
(CIVIL ENGINEERING)**

Approved by,

  
\_\_\_\_\_  
(Dr. Victor R. Macam Jr.)

**UNIVERSITI TEKNOLOGI PETRONAS**

**TRONOH, PERAK**

**June 2007**

## CERTIFICATION OF ORIGINALITY

This is to certify that I am responsible for the work submitted in this project, that the original work is my own except as specified in the references and acknowledgements, and that the original work contained herein have not been undertaken or done by unspecified sources or persons.



---

MOHD FAISAL B MOHD RADZI

## **ACKNOWLEDGEMENT**

I would like to express my appreciation to my supervisor, Dr. Victor R. Macam, whose helps, supports and guidance played a valuable part to the completion of this project.

I would also like to express my gratitude to my partner in completing this project, Rashidi bin Saemar. We had completed the project and work with each other until the end.

My gratitude also goes to Universiti Teknologi PETRONAS (UTP), especially the Civil Engineering Department that trained students with essential skills to be well-rounded, in theoretical and practical works. Also, the co-operation from the staffs towards the completion of this project.

The last but not least, to all my fellow course mates and my family, which have played significant role in order for me to complete this project.

## TABLE OF CONTENTS

### CHAPTER 1:

<b>INTRODUCTION.....</b>	<b>1</b>
1.1 Background of Study.....	1
1.2 Problem Statement.....	3
1.3 Objective.....	3
1.4 Scope of Work.....	4

### CHAPTER 2:

<b>LITERATURE REVIEW.....</b>	<b>5</b>
2.1 Earthquake.....	5
2.1.1 Beam-column Joint.....	6
2.1.2 Columns.....	8
2.2 Shake Table Test.....	11
2.3 Time-History Analysis and Pushover analysis.....	11
2.4 Response Spectrum Analysis.....	13

### CHAPTER 3:

<b>METHODOLOGY .....</b>	<b>15</b>
3.1 Building Design.....	15
3.2 Calculation of Capacity for Beams and Columns.....	16
3.2.1 Beams.....	16
3.2.2 Columns .....	17
3.3 Frame Analysis in STAAD.Pro Software.....	17
3.3.1 Static Analysis.....	17
3.3.2 Response Spectrum Analysis.....	18.

### CHAPTER 4:

<b>RESULTS AND DISCUSSION.....</b>	<b>21</b>
4.1 Results.....	21
4.2 Discussion.....	33

**CHAPTER 5: CONCLUSION AND RECOMMENDATION.....38**

5.1 Conclusion.....38

5.2 Recommendation.....38

**CHAPTER 6:**

**REFERENCES.....39**

**CHAPTER 7:**

**APPENDICES.....**

## **LIST OF FIGURES**

- Figure 1: Plate boundaries and epicenter distribution
- Figure 2: Damaged rubbish chute wall
- Figure 3: Shake table test results for 1/5-scale 3-storey RC frame (Griffith and Heneker, 1995).
- Figure 4: Front and Side Elevation of Frame K1
- Figure 5: Section 3-3
- Figure 6: Frame K1 (side) under loading in Static Analysis
- Figure 7: Maximum Bending Moment at Beam 6
- Figure 8: Maximum Shear Force at Beam 6
- Figure 9: Maximum Axial Force at Column 5
- Figure 10: Front K1 (front) under loading in Static Analysis
- Figure 11: Maximum Bending Moment at beam 6
- Figure 12: Maximum Shear Force at Beam 31
- Figure 13: Maximum Axial Force at Column 5
- Figure 14: Side Frame K1 under loading in Response Spectrum Analysis
- Figure 15: Front of Frame K1 under loading in Response Spectrum Analysis
- Figure 16:  $R_w$  values for Structural Systems in Concrete (UBC 1994)

## **LIST OF TABLES**

- |                  |   |
|------------------|---|
| <b>Table 1:</b>  | <b>Earthquakes Felt In Malaysia</b>   |
| <b>Table 2:</b>  | <b>Result of Beam Capacities</b>  |
| <b>Table 3:</b>  | <b>Columns Axial Load Capacity</b>  |
| <b>Table 4</b>   | <b>Calculation of Seismic Loads, Static Procedure UBC 1994</b>  |
| <b>Table 5:</b>  | <b>Results from Side Frame K1 Static Analysis</b>   |
| <b>Table 6:</b>  | <b>Results from Front Frame K1 Static Analysis</b>  |
| <b>Table 7:</b>  | <b>El Centro, 1940 Ground Acceleration Data</b>   |
| <b>Table 8:</b>  | <b>Results from Side Frame K1 in Response Spectrum Analysis</b>   |
| <b>Table 9:</b>  | <b>Results from Front Frame K1 in Response Spectrum Analysis</b>  |
| <b>Table 10:</b> | <b>Comparison between Static Analysis Results and the Structural Capacities for Side Frame K1</b>             |
| <b>Table 11:</b> | <b>Comparison between Static Analysis Results and the Structural Capacities for Front Frame K1</b>            |
| <b>Table 12:</b> | <b>Comparison between Response Spectrum Analysis Results and the Structural Capacities for Side Frame K1</b>  |
| <b>Table 13:</b> | <b>Comparison between Response Spectrum Analysis Results and the Structural Capacities for Front Frame K1</b> |

# CHAPTER 1

## INTRODUCTION

### 1.0 BACKGROUND

Malaysia is closed to the most two seismically active plate boundaries, the inter-plate boundary between the Indo-Australian and Eurasian Plates on the west and the inter-plate boundary between the Eurasian and Philippines Sea Plates on the east. Major earthquakes originating from these plate boundaries have been felt in Malaysia

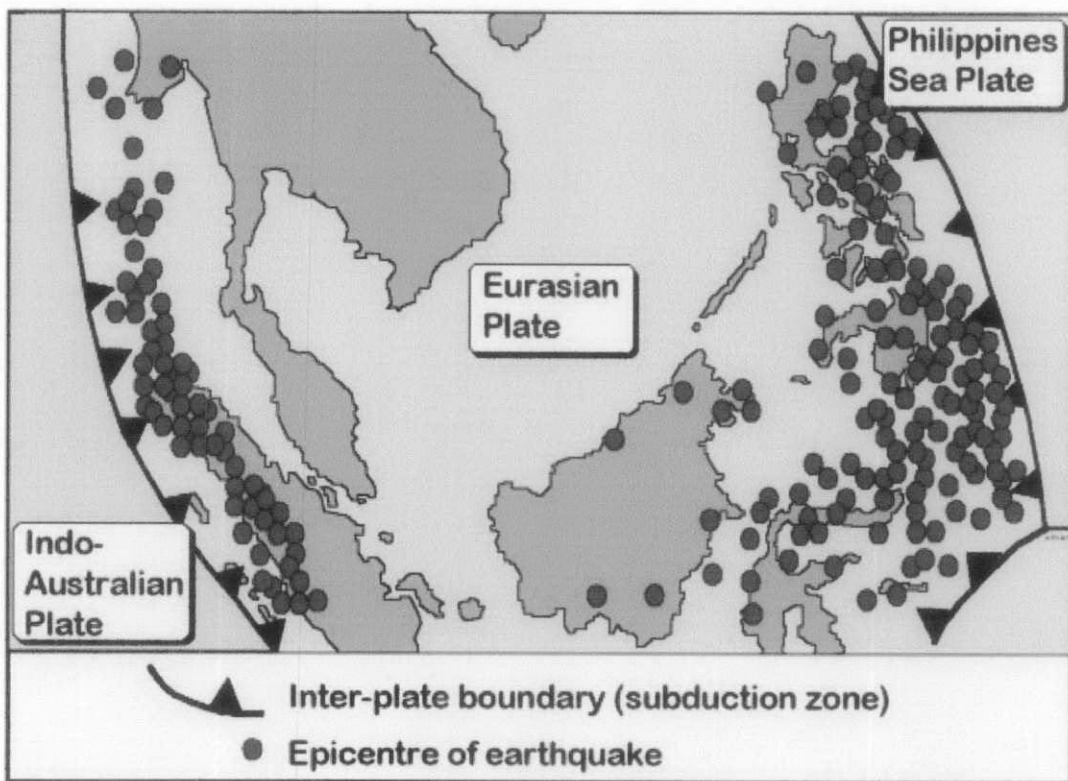

Figure 1. Plate boundaries and epicenter distribution

Tremors felt along the west coast of Peninsular Malaysia originated from large earthquakes in the active seismic areas of Sumatra and Andaman Sea.



Sabah and Sarawak meanwhile experienced tremors originating from large earthquakes located over Southern Philippines and Northern Sulawesi and also some local earthquakes, ranging from small to medium magnitudes. Several possible active faults appeared to be related to the local earthquakes.

The following photograph shows the structural damage to the rubbish chute wall of a school, caused by the local earthquake on 26 May 1991 in Ranau, Sabah.



Figure 2. Damaged rubbish chute wall

Table 1: Earthquakes Felt In Malaysia

State	Frequencies	Maximum Intensity Observed (Modified Mercalli Scale)
Peninsular Malaysia (1909-2005)		
Perlis	2	IV
Kedah	9	V
Penang	31	VI
Perak	18	VI
Selangor/Kuala Lumpur	37	VI
Negeri Sembilan	4	V
Malacca	9	V
Johor	21	VI
Pahang	4	III
Terengganu	1	IV
Kelantan	3	IV
Sabah (1923-2005)		
Sabah	24	VII
Sarawak (1923-2005)		
Sarawak	5	V

The Modified Mercalli Intensity Scale describes how earthquakes "feel" and how much destruction the earthquake causes. This scale has twelve levels designated by Roman numerals I - XII (one through twelve), to symbolize the amount of damage felt by the earthquake. Many factors determine the intensity of an earthquake at the surface of the earth, such as depth where the earthquake originates and what kinds of rock and soil are at the surface.

Ordinary buildings in Malaysia are not designed to withstand seismic load as Malaysia have never experienced earthquake and also uneconomical. Malaysia also does not have its own set of seismic code. Unlike countries which are prone to earthquake, such as United States of America and Indonesia, they have their own set of code seismic code that is used in their design for buildings. As an example, the Uniform Building Code which is widely used in United States of America.

### **1.1 PROBLEM STATEMENT**

Malaysia have never experiences major earthquake with its epicenter in near or in the country itself. Also, the buildings are not design to resist earthquake effects. Thus, the behavior of the structures under earthquakes and the performances are unknown. The capability of the beam and column to withstand earthquake is vital, especially at the beam-column joints. They are critical part of buildings. Their constituent materials have a limited strength and whenever forces applied are larger than their capacity during earthquake, severe damaged will occur.

### **1.2 OBJECTIVES**

The objectives of the project are as follows:

1. To do static and dynamic analysis of the school building
2. To gather relevant information from previous researches in order to understand the behaviors.

The benefits from this research would definitely be helpful, as people would know if the school building would be safe or not if a major earthquake would to happen in the future.

### **1.3 SCOPE OF STUDY**

The scope of this study is the analysis of behavior and performance of building structural frames through software. The school is a 3-storey building designed by JKR and that has been in use since 1991.

The initial works are to calculate flexural/bending capacity, shear capacity, torsion capacity, and cross section of properties and moment of inertia of beams as present in the structural drawings. Then, models are simulated in the software and analyzed in two types of analysis; static and dynamic analysis. Research papers are also reviewed. Every research concerning to it will be studied and the results would be included in this paper.

## **CHAPTER 2**

### **LITERATURE REVIEW**

#### **2.1 EARTHQUAKE**

##### **2.1.1 Beam-column Joint**

Beam-column connections in reinforced concrete (RC) frame structures under earthquake-induced lateral displacements are generally subjected to large shear stresses that may lead to significant joint damage and loss of stiffness in the structure.

According to **Parra-Monesinos, Peterfreund and Chao (2005)**, current design recommendations for RC beam-column joints in earthquake-resistant construction given by Joint ACI-ASCE Committee 352 (2002) focus on three main aspects: 1) confinement requirements; 2) evaluation of shear strength and 3) anchorage of beam and column bars passing through the connection.

ACI design recommendations for RC beam-column connections follow a strength-based approach, where the connection shear strength is checked against the expected force demands imposed by adjoining members. Based on those recommendations, the joint is assumed to behave satisfactorily during earthquakes if its shear strength exceeds the shear demand, a strong column-weak beam mechanism is ensured, and sufficient transverse reinforcement and anchorage length for reinforcing bars passing through the connection are provided.

The minimum amount and maximum spacing of joint transverse reinforcement are based on the requirements for critical regions of RC columns, which when combined with the longitudinal reinforcement from beams and columns, often lead to severe reinforcement congestion and construction difficulties. Furthermore, the need to satisfy the anchorage length requirements for beam and column longitudinal bars

may require either the use of large column and/or beam sections or a large number of small diameter bars, which might in turn increase reinforcement congestion in the connection.

**Lu (2002)** conducted a study on seismic behavior of multistory RC framed structures. Under the Bare Frame RC model, it was designed to satisfy seismic requirements for ductility class “Medium” with design peak ground acceleration (PGA) of 0.30g. Models are reduced to 1:5.5 and tested under simulated earthquake on an earthquake simulator. Cracking pattern and failure modes were observed. At 0.3g, a uniformly distributed cracking pattern appeared. At the next test of 0.9g, the general response Bare frame RC remained stable, but the cracking widened substantially (maximum crack width on the model exceeded 1mm) indicating excessive yielding, while spalling of concrete occurred in lower stories. Plastic hinges appeared to also occur in several columns, due to “relaxation” of column design moments from satisfying equilibrium around joints. The diagonal cracks that occurred at some beam-column joints were generally light but due to heavy reinforcements at the joints, the cracks became critical. Yong Lu also discovered there was severe damage at place where there is abrupt reduction (over 20%) of the column cross section size. The phenomenon was caused by an intensified high mode “whipping “effects.

**Lowes and Altoontash (2003)** describes that, under gravity and earthquake loading, beams would develop nominal flexural strength while column longitudinal reinforcement would carry tensile stresses that approach the yield strength. In their study, the frame member loads act as tension and carried by frame member longitudinal steel and concrete, while shear is carried by concrete. The load carried in frame member concrete meanwhile was transferred directly into the joint core concrete. The joint strength is dependent on bond strength and the joint stiffness depends on anchorage-zone deformation. Depending on the bond stress distribution, joint shear may be distributed uniformly or maybe transferred primarily through a diagonal compression strut that develops within joint core. Joint stiffness and

strength determined by the response of the joint core under nominal shear loading. Shear is transferred from frame members into the joint at the perimeter of the joint and is assumed to occur across closed concrete cracks in the vicinity of frame member flexural compression zones. If cracks at the perimeter of the joint remain open under load reversal, strength and stiffness of the interface shear transfer mechanism is reduced.

### 2.1.2 Columns

It is common for columns in multistory frame structures subjected to lateral loading to be under a shear dominant loading condition with reversed bending along the column height. **Yan Xiao and Armen Martirosyan (1998)** observed that up to certain displacement ductility levels, flexural cracks perpendicular to the column axis developed first in regions close to the top and bottom ends of the columns. The flexural cracks became inclined and extended into the web zone of the columns due to influence of shear, at the stage exceeding the first yield of longitudinal bars.

At later stages of loading, independent cracks started to occur and plastic hinges were fully formed at top and bottom of columns. In terms of flexural failure, the columns lose their capacities at some point due to longitudinal bar buckling accompanied by crushing of concrete. The ultimate performance for columns with smaller longitudinal bars, subjected to low axial load and high axial load are dominated by load-carrying capacity degradation upon cycling due to buckling of compression longitudinal bars within the columns plastic hinges. Differences in transverse steel content did not effect significant changes in the maximum load-carrying capacities. Maximum capacities were typically reached corresponding to the crushing of cover of concrete and at that stage; the transverse reinforcement was not fully activated. However, ultimate deformations are reduced for columns with less transverse reinforcements, particularly for columns subjected to axial load equal to 20% of the column axial load capacity.

The increase in smaller transverse reinforcement strains from the experiment indicates the degradation of concrete shear contributions at large displacement ductility levels. Also, columns with larger longitudinal steel content were found to developed higher lateral loading. Increased in flexural capacity also implied an increased in shear demand. However, despite the increase in shear demands, bigger longitudinal bars demonstrated improved ductility compared with columns with smaller longitudinal bars.

## 2.2 Shake Table Test

A shake table test by University of Adelaide on a 1/5 scale RC frame indicated that a “code-compatible” RC frame would respond “elastically” under the “design magnitude” earthquake. Figure 5 shows the maximum base shear versus the peak shake table acceleration recorded during the series of tests. The result suggests that the structure only began to respond inelastically at base shear levels in excess of 25% of the weight of the structure.

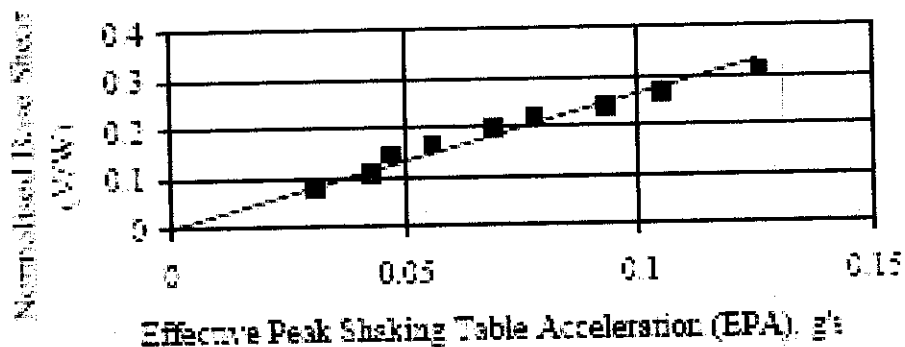

Figure 3. Shake table test results for 1/5-scale 3-storey RC frame (Griffith and Heneker, 1995).



### **2.3 Time-History Analysis and Pushover analysis**

In the dynamic time-history analysis, actual recorded motions were used. All motions include a longitudinal and a transverse component. *Kappos and Panagopoulos (2004)* improved it by scaling the intensity of the design spectrum using a modified Housner technique. This is to significantly reduce scatter in the calculated response.

A non-linear static pushover analysis is a simple option for estimating the strength capacity in the post elastic range. This procedure involves applying a predefined lateral load pattern that is distributed along building height. The lateral forces are then monotonically increased in constant proportion with a displacement control in the top of building, until a certain level of deformation is achieved. The method allows tracing the sequence yielding and failure of structural member, as well as the progress of overall capacity curve of the structure. The pushover analysis is carried out in two sequential stages: a first stage involving the application of the gravity loads; and a second stage in which the lateral loads were incrementally applied. The application of the gravity loads was performed in one single step due to the fact that none of the elements reached its yield or cracking strength.

A pushover analysis model also requires a series of hinges to account for the nonlinear behavior of the various structural elements which include RC beams, columns and the masonry elements. Another important aspect in pushover analyses also, is the definition of the lateral loads. In *Proença, Oliveira and Almeida (2002)* studies, the lateral loads were considered proportional to the product of the storey masses and the fundamental elastic mode shape. It was assumed that the mode accurately describes the predominant response pattern of the structure.

Another procedure which consist a “triangular”, code-type, distribution of lateral loading and a ‘modal’ pattern was used in the pushover analysis by *Kappos and Panagopoulos (2004)*. The forces act on the mass centers of each floor when the building is subjected to the response spectrum acting along each main axis. Modal forces were calculated taking into account the first three modes in each principal direction, which modal masses contribute about 95% of the total. The loading patterns are quite similar for regular structures; this would not be the case in stiffness asymmetric structures. In the analysis, the effect of variation of axial load on the biaxial strength of columns was accounted for, at the assessment stage, by specifying appropriate interaction surfaces ( $M_x$ - $M_y$ - $N$ ) in SAP2000 software. Ductility of each member was also estimated with due account for confinement, and  $M$ - $\theta$  curves for the rigid-plastic point hinges in the concentrated plasticity models were constructed by defining the yield moment, the ultimate moment, and the plastic rotation capacity, estimated from moment-curvature analysis and assuming an appropriate plastic hinge length. A residual strength flat part of the  $M$ - $\theta$  curve, at a level of 20% the yield moment, extending up to twice the rotation capacity, was also included.

Using Capacity Spectrum Method (CSM), *Proença, Oliveira and Almeida (2002)* further refined their structural model in order to perform a nonlinear static (pushover) analysis. The CSM allows for the consideration of the complex, but representative, behavior of the structure and has a clearer physical support than other nonlinear static procedures such as the Displacement Coefficient Method, DCM, and the N2 Method. CSM has been recommended (Albanesi et al., 2002) as a method that, when compared with nonlinear dynamic analyses, satisfactorily predicts maximum displacements for all structural types, including tall frame structures. The nonlinear structural model comprised PMM hinges (P – axial force; MM – bi-axial moments) for columns, M3 hinges (uniaxial moment) for beams, and P hinges (axial force) for the diagonal strut elements.

## 2.4 Response Spectrum Analysis

In a linear-elastic response spectrum analysis, response spectra define the free field ground motion for the design earthquake. A response spectrum gives the maximum damped response (expressed as displacement, velocity, or acceleration) of all possible linear single degree-of-freedom systems using the natural frequency (or period) to describe the system. Viscous damping expressed as a percentage of critical damping is used to develop response spectra. A design earthquake is often defined by a set of response spectra for various damping ratios. The response spectra produced by recorded earthquake events are characterized by a jagged shape made up of peaks and valleys of varying magnitude; however, design response spectra are smoothed so that they are not frequency sensitive.

Design response spectra are developed by using either a “deterministic approach” or a “probabilistic approach.” The probabilistic approach is based on probabilistic seismic hazard analysis methodology which in essence uses the same elements as the deterministic approach, but adds an assessment of the likelihood that ground motion will occur during a specified time period. There are two basic procedures for developing design response spectra using either the deterministic or probabilistic approach. They are: (1) anchoring the spectral shape to the peak ground acceleration; and (2) estimating the spectrum directly. Although procedure (1) is more often used, the use of procedure (2) is increasing, and for some situations is preferred because it incorporates factors besides just the local site conditions.

Once the modes are derived, the response of the complex multiple degree of-freedom system is reduced to the solution of the simple, single basic equation of motion for a single degree-of-freedom (SDOF) system. For time-history analysis, the response is easily obtained using step by-step integration of the equation of motion

for the SDOF system for each significant mode based on the frequency (eigenvalue) of the mode. In essence the response contribution of each mode is determined for a series of time steps using a prescribed time-step interval, and the response at each time step is simply the superposition, or addition, of characteristic mode shapes adjusted by coefficients obtained from the integration procedure. Normally, only a few mode shapes are found to contribute significantly to the response, so that the modal produces a precise response with minimum computational effort.

In a response spectrum analysis, the step-by-step integration part of the dynamic analysis for time history analysis is performed in the process of developing the response spectrum. The response spectrum may be envisioned as a display of the results of this part of the modal analysis, and it is presented in the form of “maximum” response versus frequency (or period). In the response spectrum modal analysis, eigenvalues, eigenvectors, and modal participation factors are computed and used in the analysis procedure just as they are in a time-history modal analysis. Precise “maximum” modal responses are easily calculated from a simple equation that relates these parameters and the appropriate spectral value that corresponds to the modal frequency.

## CHAPTER 3 METHODOLOGY

### 3.1 School Building Design

The school structure was three stories tall and had eight symmetric bays in each direction. The plan and elevation views are shown in Figure 6. The building used concrete strength of  $21\text{N/mm}^2$  and reinforced steel with yield strength of  $460\text{ N/mm}^2$ .

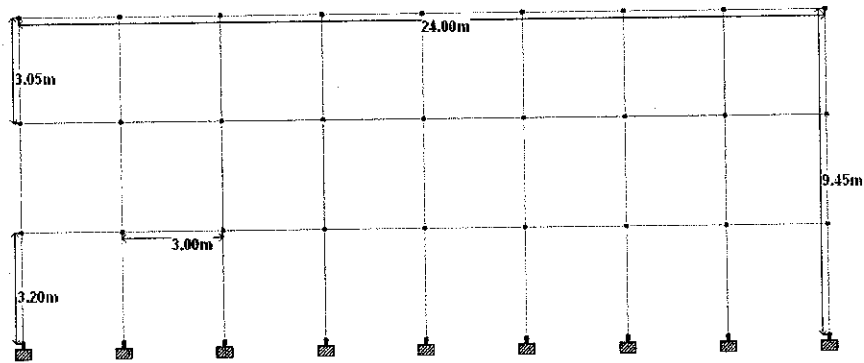

(a) Front Frame K1

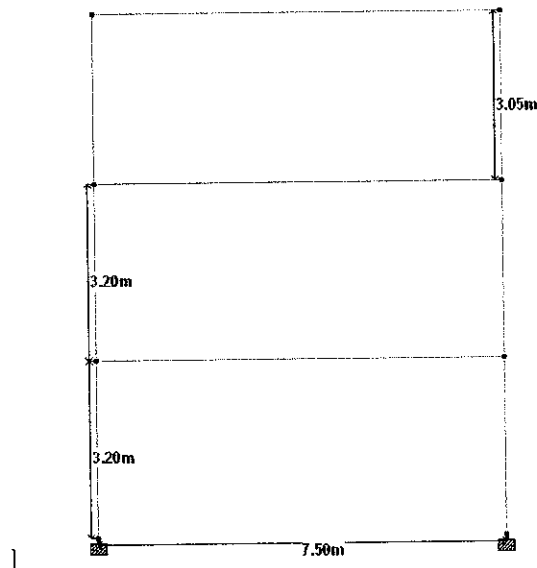

(b) Side Frame K1

Figure 4: Front and Side Elevation of Frame K1

## 3.2 Formula and Calculation of Capacity for Beams and Columns (Using ACI Code)

### 3.2.1 Beams

Section 3-3 (longitudinal bar: (top) 2Y20, (bottom) 3Y20; Transverse bar: 30R10-250)

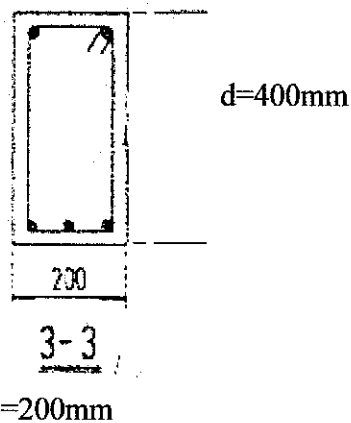

Figure 5. Section 3-3

#### 1. Ultimate Moment Strength, $M_n$

- $A_s = 1420\text{mm}^2$
  - $f_y = 460\text{N/mm}^2$
  - $f'_c = 30\text{N/mm}^2$
- 
- $T = A_s f_y = (1420 \times 460) = 653.2 \text{ kN}$
  - $a = T / (0.85 \times f'_c \times b) = 128\text{mm}$
  - $M_n = T(d - a/2) = 197 \text{ kN.m}$

## 2. Shear, $V_u$

- $f_c = 30 \text{ N/mm}^2$
- $\phi = 0.75$
- $V_u = \phi V_c + \phi V_s$
- $V_c = (\sqrt{f_c}/6) b_w d = 66.64 \text{ kN}$
- $V_s = \frac{1}{3} \sqrt{f_c} b_w d = 133.28 \text{ kN}$
- $V_u = (0.75)(66.64 \text{ kN}) + (0.75)(133.28 \text{ kN}) = 150 \text{ kN}$

## 3. Torsion, $T_u$

- $T_u = \phi \frac{\sqrt{f_c} (A_{cp}^2 / p_{cp})}{12}$   
 $= \frac{(0.75)(\sqrt{30}) ((80000)^2 / 12000)}{12}$   
 $= 1.83 \text{ kN.m}$

## 4. Development Length

- $l_d = 9 \frac{f_y \alpha \beta \gamma \lambda}{10 \frac{\sqrt{f_c} (c + K_{tr})}{d_b}}$  (unit: diameters)  
 $= 129 \text{ diameters}$

### 3.2.2 Columns

#### Axial Load Capacity, $P_u$

- $P_u = \phi P_n = 0.80 \phi [0.85 f_c (A_g - A_{st}) + f_y A_{st}]$  (unit: kN);
- $\phi$  value as specified in Section 9.3.2 of the Code; 0.7 for tied columns

### 3.3 Equivalent Static Force Procedure

#### Design Base Shear

The total seismic lateral force, also called the base shear is determined by the relation

$$V = \frac{ZIC}{R_w} W$$

- $R_w$  = Response Modification Factor. A measure of ability of structure to withstand earthquake motions without collapse. Represents the ratio of forces in an entirely linear elastic system to the forces anticipated in a system with significant yielding.
- $W$  = Total seismic dead load of the building and applicable portions of other loads. Represent the total mass of the building and includes the weight of structural slabs, beams, columns and wall. Non structural components such as floor roofing, fixed electrical and mechanical equipment, partitions and ceiling. To determine the overall weight  $W$ , it is necessary to evaluate tributary weight  $W$ , for both vertical and horizontal distribution of loads.
- $Z$  = Seismic zone factor with following values:

Seismic Zone	Peak Ground Acceleration (PGA)
4	0.4
3	0.3
2B	0.2
2A	0.15
1	0.075
0	0

- $S$  = Site coefficient with values of 1.0, 1.2, 1.5 and 2.0 as defined
  - 1.0 = for soil profile either a rock-like material characterized by a shear wave velocity greater than 2500ft/s or stiff /dense soil



conditions where the soil depth is less than 200 ft (soil profile type S1)

- 1.2 = for soil profiles with dense/stiff soil conditions, where the soil depth exceeds 200ft (soil profile type S2)
- 1.5 = for a soil profile 70 ft or more in depth and containing more than 20ft of soft to medium-stiff clay but not more than 40ft of soft clay (soil profile type S3)
- 2.0 = for a soil profile containing more than 40 ft soft clay characterized by a shear-wave velocity less than 500ft (soil profile type S3)
- C = Coefficient related to the fundamental period of vibration of the structure,  $T$ , including the site structure response factor,  $S$ .

$$C = \frac{1.25S}{T^{2/3}}$$

- I = Importance factor with four factor of occupancy: essential, hazardous, special and standard. Essential and hazardous occupancies are assigned an Importance factor of 1.25 while special and standard occupancies are permitted I =1.0
- T = Fundamental period of vibration of the structure. For reinforced concrete moment resisting frame;  $T_a = 0.030h_n^{3/4}$
- Base shear distribution along building height;

$$F_x = \frac{(V-F_t)w_x h_x}{\sum_{i=1}^n w_i h_i}$$

### 3.4 Frame Analysis in STAAD.Pro Software

The selected frame is simulated in the software to investigate its behavior under earthquake. The frame is studied using:

- Static Analysis
- Response Spectrum Analysis

### 3.3.1 Static Analysis

The STAAD Seismic Load Generator is utilized in order to determine equivalent static lateral loads acting on the frame due to seismic forces. The rules available in Uniform Building Code 1994 (UBC 1994) are used.

The STAAD seismic load generator assumes that the lateral loads will be exerted in X and Z directions and Y will be the direction of the gravity loads. Thus, for a building model, Y axis will be perpendicular to the floors and point upward.

Total lateral seismic force or base shear is automatically calculated by STAAD using the appropriate UBC equation(s).  $V = (ZIC / R_w) W$  (per UBC 1994)

STAAD utilizes the following procedure to generate the lateral seismic loads.

- Seismic zone co-efficient and desired UBC specifications are provided through the DEFINE UBC LOAD command.
- The program calculates the structure period T.
- Then the program calculates C from appropriate UBC equation(s) utilizing T.
- Program calculates V from appropriate equation(s). W is obtained from the weight data (SELFWEIGHT, JOINT WEIGHT(s), etc.) provided through the DEFINE UBC LOAD command.
- The total lateral seismic load (base shear) is then distributed by the program among different levels of the structure per UBC procedures.

### 3.3.2 Response Spectrum Analysis

This capability allows the user to analyze the structure for seismic loading. For any supplied response spectrum (either acceleration vs. period or displacement vs. period), joint displacements, member forces, and support reactions may be calculated. Modal responses may be combined using one of the square root of the sum of squares (SRSS), the complete quadratic combination (CQC), the ASCE4-98 (ASCE), the Ten Percent (TEN) or the absolute (ABS) methods to obtain the resultant responses. Results of the response spectrum analysis can be combined with the results of the static analysis to perform subsequent design. To account for reversibility of seismic activity, load combinations can be created to include either the positive or negative contribution of seismic results.

#### General Format:

$$\text{SPECTRUM} \left\{ \begin{array}{l} \text{SRSS} \\ \text{ABS} \\ \text{CQC} \\ \text{ASCE} \\ \text{TEN} \end{array} \right\} * \left\{ \begin{array}{l} \text{X } f1 \\ \text{Y } f2 \\ \text{Z } f3 \end{array} \right\} \left\{ \begin{array}{l} \text{ACC} \\ \text{DIS} \end{array} \right\} (\text{SCALE } f4) \\ \left\{ \begin{array}{l} \text{DAMP } f5 \\ \text{CDAMP} \\ \text{MDAMP} \end{array} \right\} \left( \left\{ \begin{array}{l} \text{LIN} \\ \text{LOG} \end{array} \right\} \right) (\text{MIS } f6) (\text{ZPA } f7) (\text{FF1 } f8) (\text{FF2 } f9) (\text{SAVE})$$

The data in the first line above must be on the first line of the command, the remaining data can be on the first or subsequent lines with all but last ending with a hyphen (limit of 3 lines).

Starting on the next line, Spectra are entered in one of these two input forms:

$$\left\{ \begin{array}{l} \text{P1 V1; P2 V2; P3 V3;.....} \\ \text{or} \\ \text{FILE } fn \end{array} \right\} \quad \begin{array}{l} \text{(with DAMP, CDAMP, or MDAMP)} \\ \text{(with CDAMP or MDAMP)} \end{array}$$

- SRSS, ABS, CQC, ASCE4-98 & TEN Percent are methods of combining the responses from each mode into a total response.
- X Y Z f1, f2, f3 are the factors for the input spectrum to be applied in X, Y, & Z directions.

- **ACC or DIS** indicates whether Acceleration or Displacement spectra will be entered.
- **SCALE f4** = Scale factor by which the spectra data will be multiplied. Usually to factor g's to length/sec<sup>2</sup> units.
- **DAMP, CDAMP, MDAMP.** Damping input. **DAMP** indicates to use the f5 value for all modes. **CDAMP** indicates to use Composite modal damping if entered, otherwise same as **MDAMP**. **MDAMP** indicates to use the damping entered or computed with the **DEFINE DAMP** command if entered, otherwise default value of 0.05 will be used.
- **LIN or LOG.** Select linear or logarithmic interpolation of the input Spectra versus Period curves for determining the spectra value for a mode given its period. **LIN** is default. Since Spectra versus Period curves are often linear only on Log-Log scales, the logarithmic interpolation is recommended in such cases; especially if only a few points are entered in the spectra curve.
- **P1, V1; P2, V2; .... ; Pn, Vn.** Period – Value pairs (separated by semi colons) are entered to describe the Spectrum curve. Period is in seconds and the corresponding Value is either acceleration (current length unit/sec<sup>2</sup>) or displacement (current length unit) depending on the **ACC** or **DIS** chosen. Spectrum pairs are in ascending (or descending) order of period. If data is in g acceleration units, function **SCALE** is set to a convert factor to the current length unit (9.807, 386.1, etc.).

**CHAPTER 4**  
**RESULTS AND DISCUSSION**

**4.1 RESULTS**

**Structural Capacities of Frame K1**

The compressive strength value ( $f_c$ ) and yield strength of reinforcement ( $f_y$ ) used in all of the calculations are  $f_c = 30 \text{ N/mm}^2$  and  $f_y = 460 \text{ N/mm}^2$ . The capacities are calculated according to the details as in the structural drawing. Shown below is the calculation of section 3-3 of Frame K1 roof beam. The rest are simplified in table 5. Structural details of other beams and columns are in APPENDIX C.

Table 2. Result of Beam Capacities

• *Ultimate Moment Strength*

Section	Width (b) (mm)	Depth (d) (mm)	Area of steel (As)	Ultimate Moment Strength(kN.m)
1-1	150	565	796	181.84
2-2	150	515	796	163.54
4-4	200	365	2322	230.08
6-6	200	465	1910	332.87
7-7	200	515	1910	344.36
8-8	200	515	3183	453.80

- Shear

Section	Effective width ( $b_w$ )	Depth (d) (mm)	$V_c$ (kN)	$V_s$ (kN)	Shear, $V_u$ (kN)
1-1	150	565	64.73	129.46	145.64
2-2	150	515	59	118	132.75
4-4	200	365	78.67	133.28	149.94
6-6	200	465	78.67	169.79	191
7-7	200	515	71.03	142.06	159.82
8-8	200	515	71.03	142.06	159.82

- Torsion

Section	$A_{cp}$	$P_{cp}$	Torsion, $T_u$ (kN.m)
4-4	80000	1200	1.83
6-6	100000	1400	2.45
7-7	110000	1500	2.76
8-8	110000	1500	2.76

- Development Length

Section	Cover (mm)	$D_b$	Development Length (diameters)
4-4	25	54.37	164
6-6	25	49.31	149
7-7	25	49.31	149
8-8	25	63.66	192

Table 3. Columns Axial Load Capacity

Section	Width (b) mm	Depth (d) mm	Axial Load Capacity (kN)
5-5	350	250	1190

## LOADS ACTING ON THE STRUCTURAL FRAME

### Floor Dead and Live Loads

The dead loads acting on the floor are as follows:

- Floor finish 0.00956 kN/m<sup>2</sup>
- Suspended electrical and ductwork 0.478 kN/m<sup>2</sup>
- Ceiling finish 0.00956 kN/m<sup>2</sup>

The ASCE 7-02 load specification suggest that a minimum classrooms in schools live load of 1.912 kN/m<sup>2</sup>

### Roof Dead and Live Loads

The dead loads acting on the floor are as follows:

- Roof Finish 0.239kN/m<sup>2</sup>
- Suspended electrical and ductwork 0.478kN/m<sup>2</sup>
- Ceiling finish 0.00956 kN/m<sup>2</sup>

The ASCE 7-02 load specification suggest that a live load on the roof schools live load of 0.956 kN/m<sup>2</sup>

### Loads Acting on the beams

#### Side Frame K1

##### 1<sup>st</sup> floor and 2<sup>nd</sup> floor beam

$$\begin{aligned}\text{Total Dead Load} &= \text{Beam Self weight} + \text{Load from slab} + \text{Brick wall} + \text{Finishes Dead} \\ &\quad \text{Load} \\ &= (\text{density of concrete} \times \text{depth} \times \text{width}) + (\text{slab self weight} + \text{load} \\ &\quad \text{distributed by slab}) + (\text{density of brick} \times \text{brick's thickness} \times \text{wall} \\ &\quad \text{height}) + (\text{Floor finishing}) + (\text{ceiling finishing}) \\ &= 20.284 \text{ kN/m}\end{aligned}$$

### Roof Beam

$$\begin{aligned}\text{Total Dead Load} &= \text{Beam Selfweight} + \text{Roof finishes} + \text{ceiling finishes} + \\ &\quad \text{Suspended electrical and ductwork} \\ &= 1.92 \text{ kN/m}\end{aligned}$$

### **Front Frame K1**

#### First and Second Floor Beam

$$\begin{aligned}\text{Total Dead Load} &= \text{Beam Self weight} + \text{Dead Load from Slab} + \text{Brick wall weight} + \\ &\quad \text{Dead Load of Finishes} \\ &= (\text{density of concrete} \times \text{depth} \times \text{width}) + (\text{slab self weight} + \text{load} \\ &\quad \text{distributed by slab}) + (\text{density of brick} \times \text{brick's thickness} \times \text{wall} \\ &\quad \text{height}) + (\text{Cement render dead load}) \\ &= 1.73 \text{ kN/m} + 1.55 \text{ kN/m} + 5.32 \text{ kN/m} \\ &= 8.6 \text{ kN/m}\end{aligned}$$

### Roof Beam

$$\begin{aligned}\text{Total Dead Load} &= \text{Beam Selfweight} + \text{Roof finishes} + \text{ceiling finishes} + \text{Suspended} \\ &\quad \text{electrical and ductwork} \\ &= 2.16 \text{ kN/m}\end{aligned}$$



## EQUIVALENT STATIC FORCE PROCEDURE

Building Height,  $h_n = 9.45$  m

The Storey heights are 3.2 m for the first and second floor and 3.05 m for roof level.

Fundamental Period  $T = 0.03(h_n)^{3/4} = 0.030(9.45)^{3/4} = 0.389$  sec

Seismic zone factor  $Z = 0.075$

Importance factor  $I = 1.0$

Response modification factor  $R_w = 5$  (ordinary moment-resisting frame, OMRF)

Soil factor  $S = 1.0$

Coefficient  $C = \frac{1.25S}{T^{2/3}} = \frac{1.25 \times 1.0}{(0.389)^{2/3}} = 2.35$

$$\frac{1.25S}{T^{2/3}} = \frac{1.25 \times 1.0}{(0.389)^{2/3}} = 2.35$$

Building Seismic Weight  $W = 108\,736.49$  kN

Base Shear  $V = \frac{ZIC}{R_w} W = \frac{0.075 \times 1.0 \times 0.389}{5} (108736.49) = 634.48$  kN

Table 4 Calculation of Seismic Loads, Static Procedure UBC 1994

Level (1)	H (2)	$\Delta h$ (3)	$w$ , kN (4)	$\sum w$ , kN (5)	$w \times h$ (6)	$\frac{wh}{\sum wh}$ (7)	V x (7) F (kN)	$\sum$ F (kN)
3	9.45		31 917.15		301,617.07	0.448	284.25	115.36
2	6.4	3.05	39 354.09		251,866.18	0.374	237.30	384.24
1	3.2	3.2	37 465.25		119,888.8	0.178	112.94	521.24
Ground	0							634.48
$\Sigma$			108736.49		673,372.05			

## SOFTWARE ANALYSIS

### Static Analysis

#### Case 1: Seismic zone 1

The seismic load is defined according to the parameters available in UBC 1994. In this case, seismic zone 1 is chosen and only this zone is suitable for this type of frame structure. This affected the value of response modification factor ( $R_w$ ) used in the analysis. In zone 1, the value of  $R_w$  is 5. The value of seismic zone factor ( $Z$ ) for zone 1 is 0.075. The Importance Factor ( $I$ ) and the site coefficient values ( $I$ ) are 1.

#### Side Frame of K1

The load inputs are in terms of uniformly distributed loads. The loads for first and second floor beams are 20.29 kN/m. For roof beam, calculated load is 1.92 kN/m.

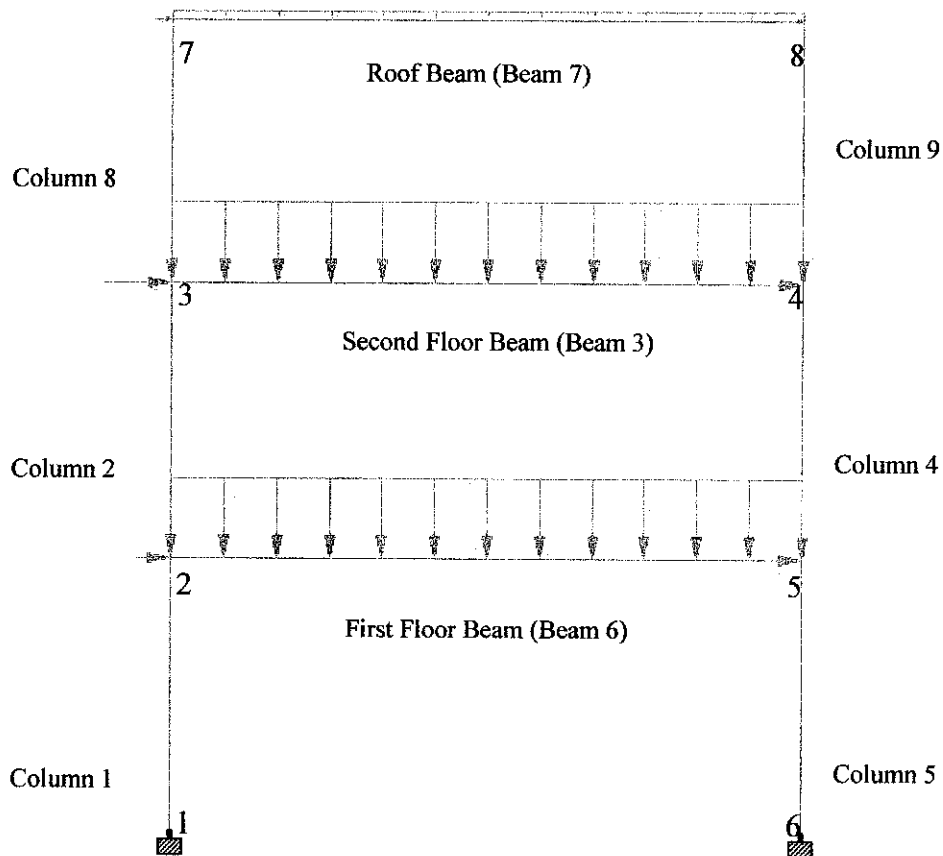

Figure 6. Frame K1 (side) under loading in Static Analysis

Table 5. Results from Side Frame K1 Static Analysis

Maximum Node Displacements	Maximum Bending Moment	Maximum Shear Force	Maximum Axial Force
6.3 mm at node 8	89.55 kN.m at beam 6	91 kN at beam 6	21.4 kN at column 5

Table 5 shows the results that are significant in the analysis. Maximum bending moment and maximum shear force occurred at beam 6. Meanwhile, maximum axial force occurred at column 5. Figure 7, 8 and 9 shows the graphs for above results.

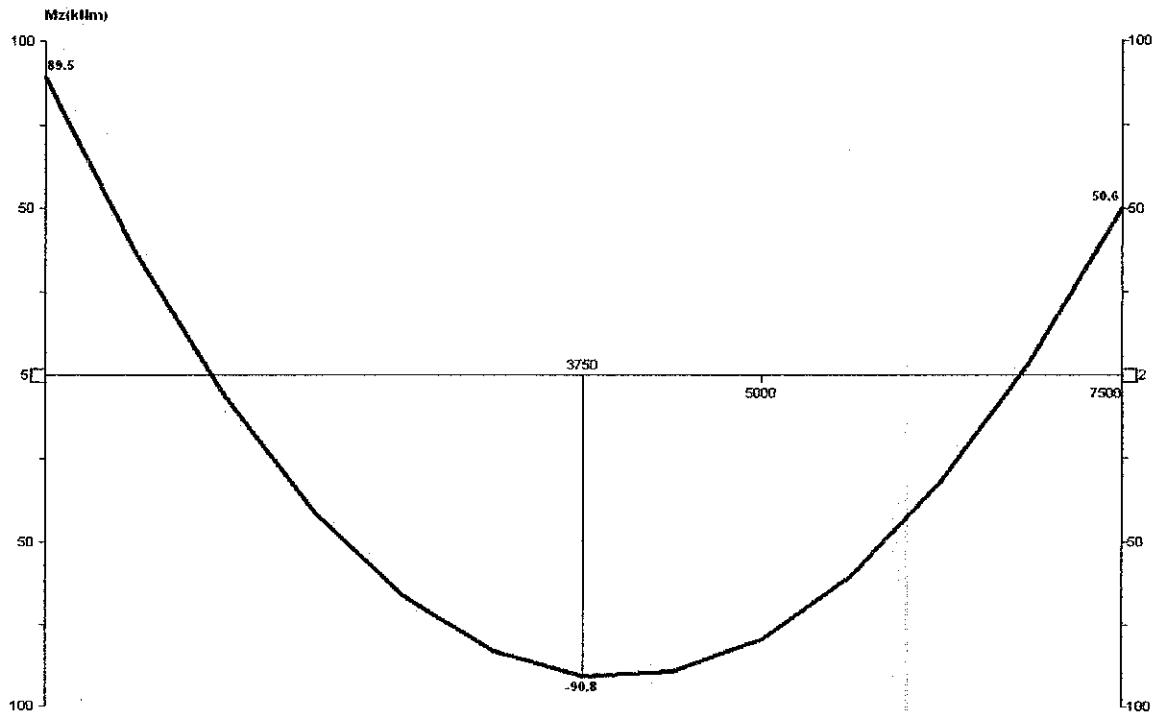

Figure 7. Maximum Bending Moment at Beam 6

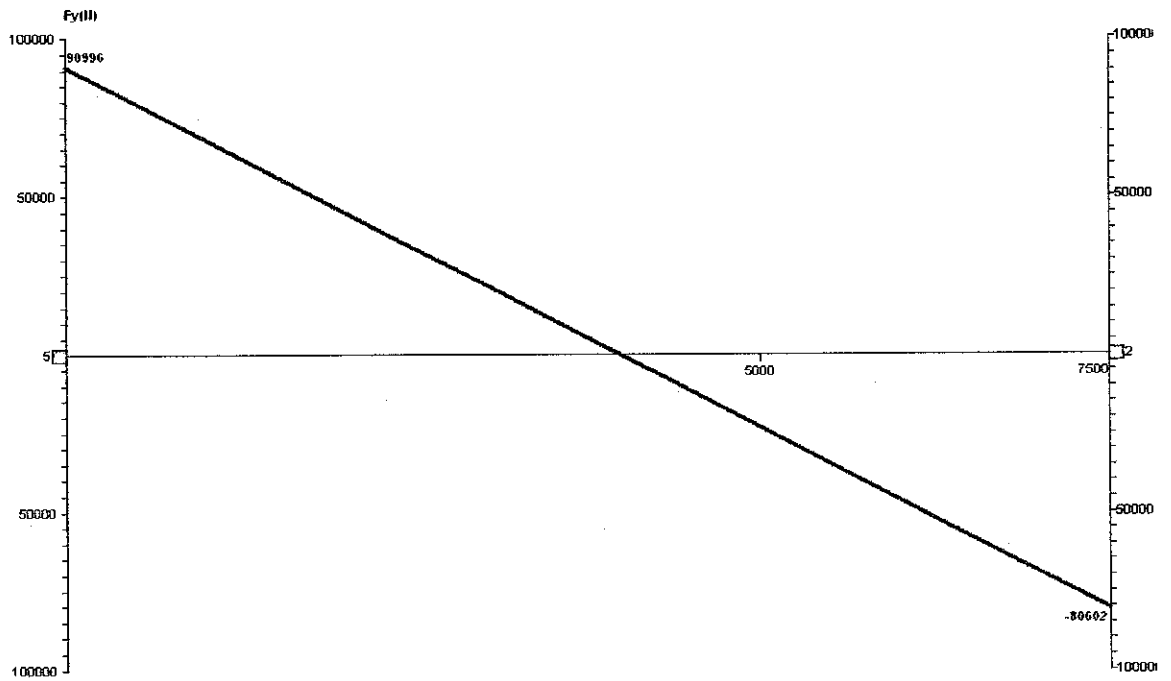

Figure 8. Maximum Shear Force at Beam 6

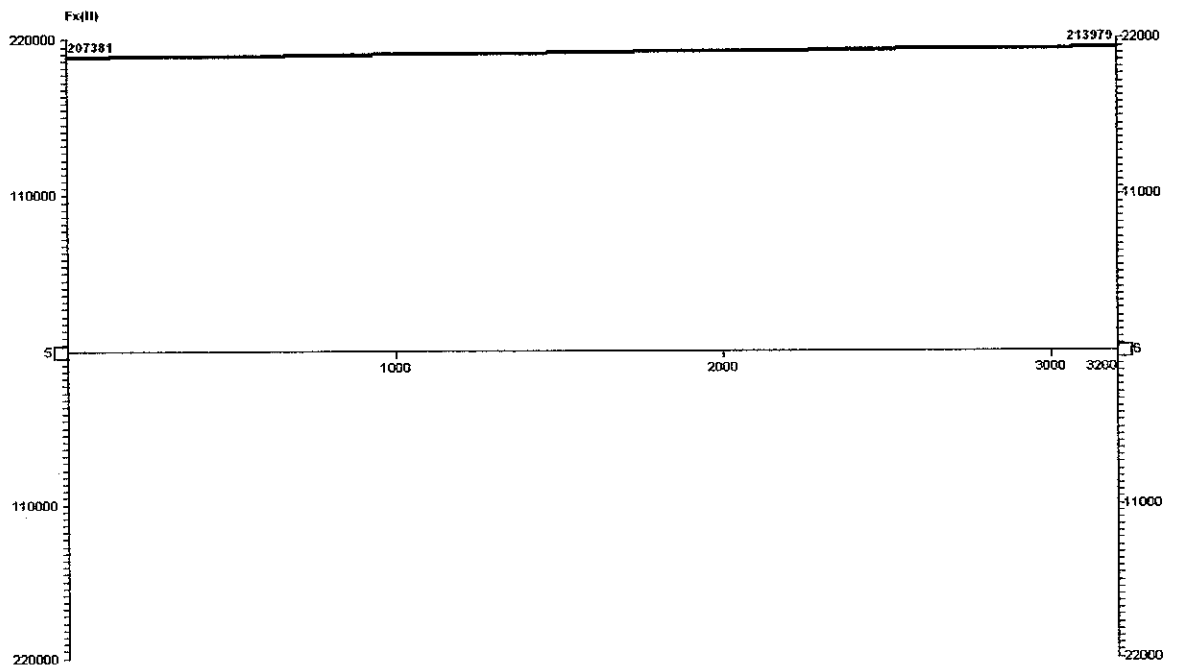

Figure 9. Maximum Axial Force at Column 5

### Front Frame of K1

The load inputs are in terms of uniformly distributed loads. The loads for first and second floor beams are 11.6 kN/m. For roof beam, calculated load is 2.22 kN/m.

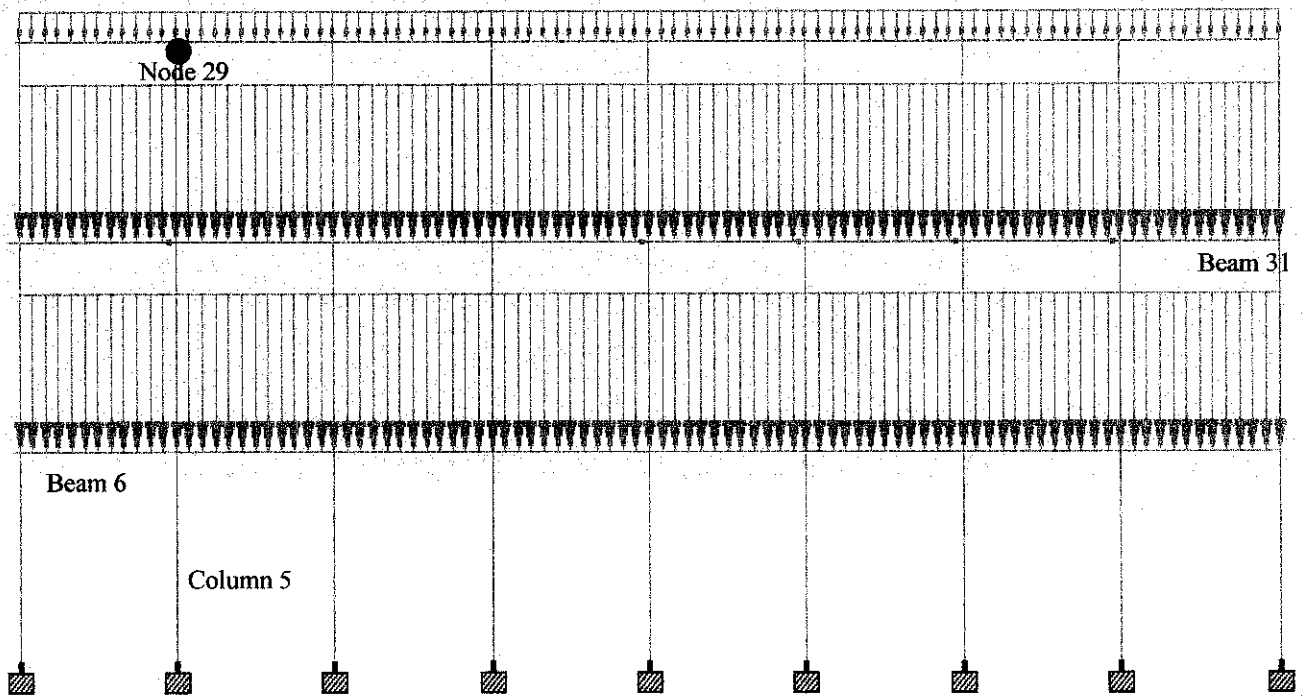

Figure 10. Front K1 (front) under loading in Static Analysis

Table 6. Results from Front Frame K1 Static Analysis

Maximum Node Displacements	Maximum Bending Moment	Maximum Shear Force	Maximum Axial Force
2.4 mm at node 29	16.74 kN.m at node 5 of beam 6	19.45 kN at beam 31	119 kN at column 5

Table 6 shows the value of maximum node displacements, bending moment, shear force and axial force for the analysis. Maximum node displacements occurred at node 29, with value of 2.4 mm. Maximum bending moment meanwhile, occurred at beam 6 of 16.74kN.m. Maximum shear force of 19.45kN occurred at beam 31 and Maximum Axial Force at column 5 at 1199 kN. Figure 11, 12 & 13 displays the actual graphical value of above results.

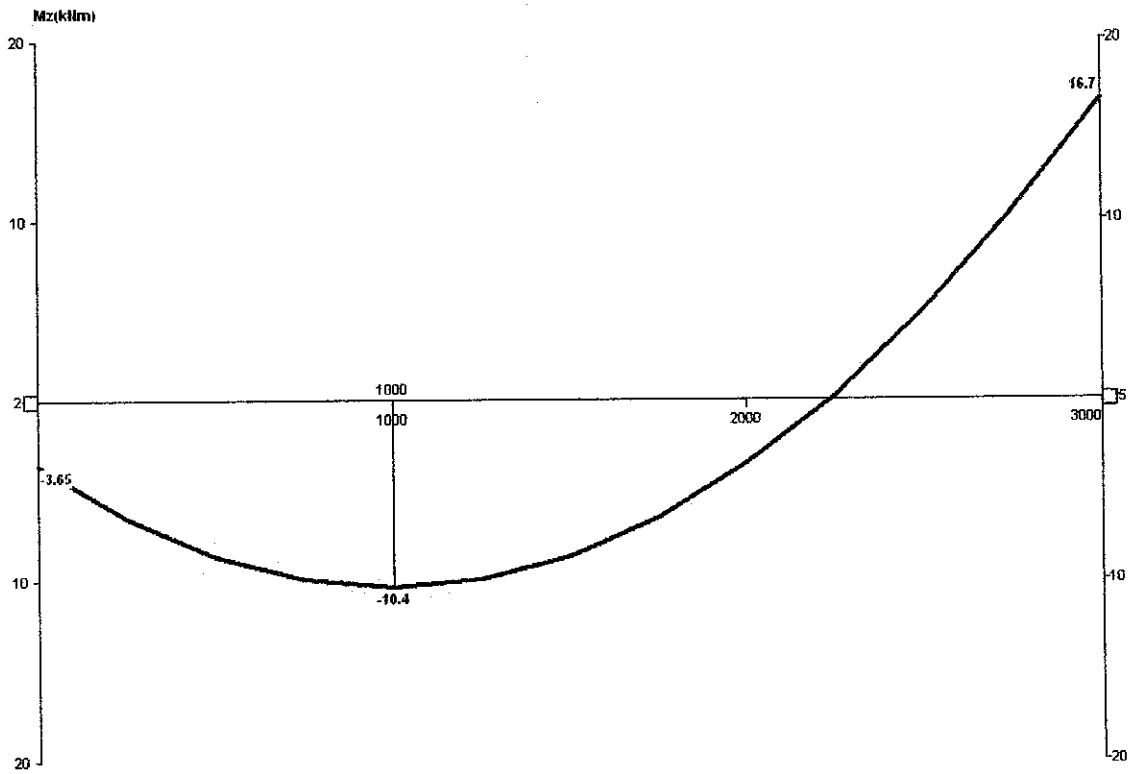

Figure 11. Maximum Bending Moment at beam 6

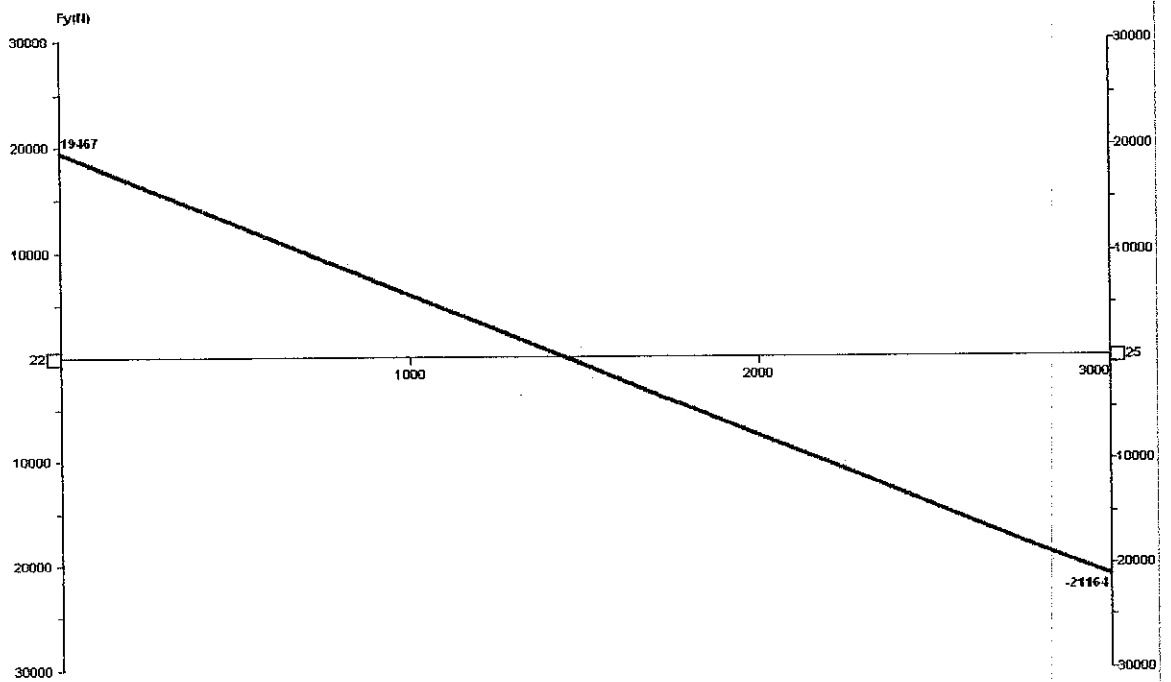

Figure 12. Maximum Shear Force at Beam 31

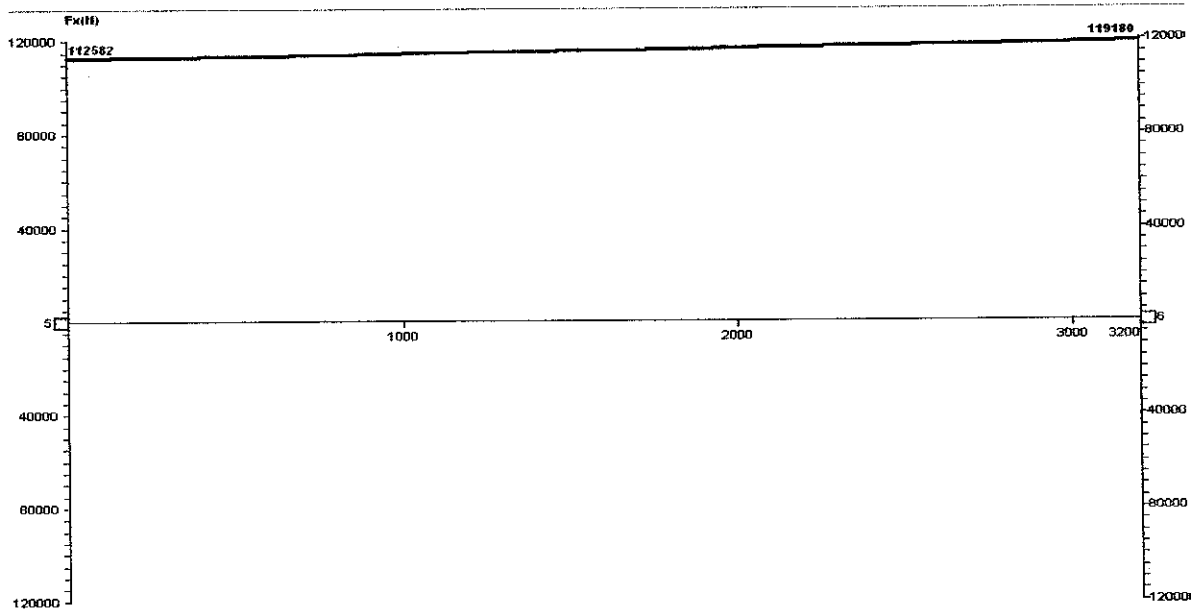

Figure 13. Maximum Axial Force at Column 5

## RESPONSE SPECTRUM ANALYSIS

Case 1: El Centro 1940 Earthquake Ground Motion

### Side of Frame K1

#### INPUT

In this analysis, the loadings are defined in 4 cases. For case 1, it is defined as the dead and live loads. Self weight of the structure and uniformly distributed load in chapter 4.2 are applied in  $-y$  direction. In case 2, seismic loading is defined. Self weight in  $x$ -direction and  $y$ -direction is applied. Complete Quadratic Combination (CQC) is chosen in the analysis with damping of 5%, selection of acceleration spectra, and scale factor of 9.806. The values of periods and the corresponding accelerations are as in Table 9. The Load case no 3 & 4 are combination cases. Load combination case no. 3 consists of the sum of the static load case (load case no 1) with the positive direction of the dynamic load case (load case no 2). Load combination case no. 4 consists of the sum of the static load case (load case no 1) with the negative

direction of the dynamic load case (load case no2). In both cases, the result is factored by 0.75.

Table 7. El Centro, 1940 Ground Acceleration Data

Time, t (sec)	Acceleration , g
0.02	0.00630
0.06	0.00099
0.1	0.00758
0.2	-0.00368
0.4	0.1290
0.6	0.02449
1.0	-0.06846
1.6	0.02849
2.0	-0.22863
2.44	0.299099
3.0	0.04458

## OUTPUT

Table 8. Results from Side Frame K1 in Response Spectrum Analysis

Maximum Node Displacements	Maximum Bending Moment	Maximum Shear Force	Maximum Axial Force
30 mm at node 7	114.35 kN.m at beam 6	85.81 kN at beam 3	205.36kN at column 1

Table 8 shows results for response spectrum analysis using El Centro Ground Motion data. The maximum node displacements is 30 mm at node 7, maximum bending moment of 114.35 kN.m at beam 6, maximum shear force of 85.81 kN at beam 3 and maximum axial force of 205.36 kN at column 1.



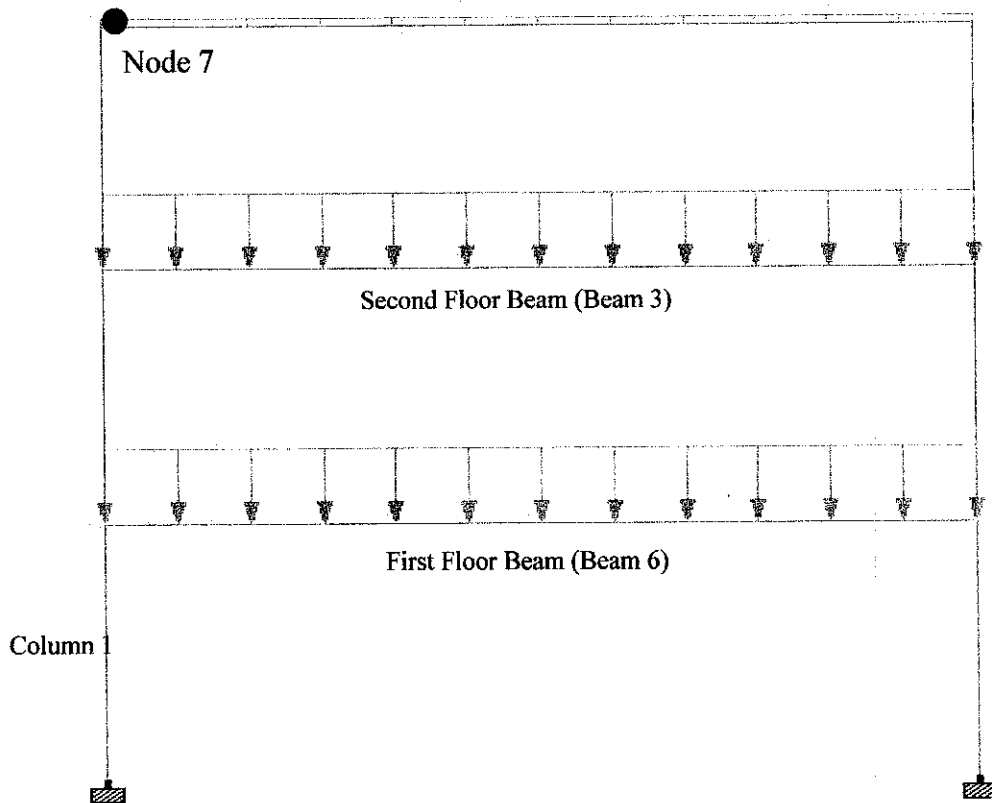

Figure 14. Side Frame K1 under loading in Response Spectrum Analysis

### Front Frame of K1

#### INPUT

Same load cases are applied in this analysis. However, the uniform distributed loading in case of dead and live loads are different. The loads for first and second floor beams are 11.6 kN/m. For roof beam, calculated load is 2.22 kN/m

#### OUTPUT

Table 9. Results from Front Frame K1 in Response Spectrum Analysis

Maximum Node Displacements	Maximum Bending Moment	Maximum Shear Force	Maximum Axial Force
8 mm at node 32	23.96 kN.m at beam 6	27.06 kN at beam 34	117.17 kN at column 5

Table 9 shows results for response spectrum analysis for front frame K1. The maximum node displacements is 8 mm at node 32, maximum bending moment of 23.96 kN.m at beam 6, maximum shear force of 27.06 kN at beam 3 and maximum axial force of 117.17 kN at column 5.

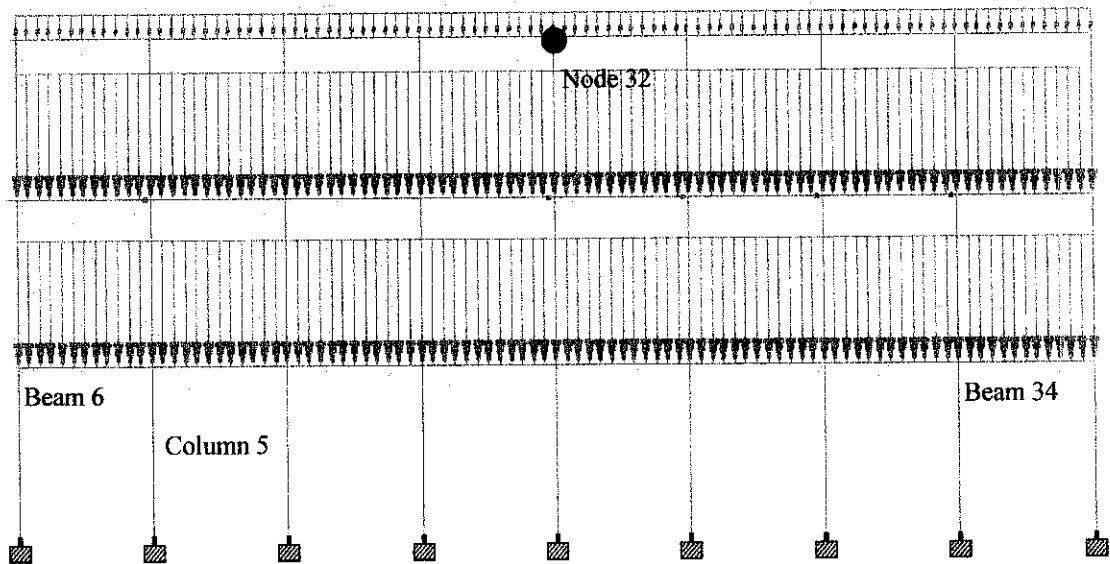

Figure 15. Front of Frame K1 under loading in Response Spectrum Analysis

## **4.2 DISCUSSIONS**

### **Preliminary Analysis**

Preliminary analysis consisted of calculation for beam and column capacities and literature review researches. All the required information for calculation, such as concrete cover thickness, grade of concrete, size of reinforcements are available in the structural drawing of the school building (refer to APPENDIX C). The results from the calculation are then compared with the value obtained in STAAD Pro analysis to determine if the current capacity is enough or safe to withstand seismic during earthquakes.

Standard values of load such as live load for school building are taken from ACI (2000) code, BS 8110 and 6399 for certain standard values. Manual Calculations are then performed to calculate the dead load imposed on the beam, which came from the beam self weight, finishes, as well as load from slabs. All of these values are then being input to STAAD Pro for analysis of the frame.

### **Static analysis**

In the static analysis, the analysis could only be done in seismic zone 1. The reason for this is, since the building is an ordinary moment resisting frames, it is only allowed to be designed in zone 1(refer to figure 16).

<b><math>R_w</math> Values for Structural Systems in Concrete</b>						
System	Zones 3 and 4		Zone 2		Zone 1	
	$R_w$	H	$R_w$	H	$R_w$	H
<b>Bearing wall system</b>						
• Shear walls	6	160	6	NL	6	111
• Braced frames	Not allowed		4	111	4	111
<b>Building frame system</b>						
• Shear walls	8	240	8	NL	8	111
• Braced frames	Not allowed		8	NL	8	111
<b>Moment resisting frame</b>						
• SMRF	12	NL	12	NL	12	111
• IMRF	Not allowed		8	NL	8	111
• OMRF	Not allowed		Not allowed		5	NL
<b>Dual Systems</b>						
• Shear wall + SMRF	12	NL	12	NL	12	111
• Shear walls + IMRF	Not allowed		9	NL	9	111
• Braced frame + SMRF	Not allowed		9	NL	9	111
• Braced frame + IMRF	Not allowed		6	NL	6	111

SMRF: Special Moment Resisting Frame (Ductile Frame).  
IMRF: Intermediate Moment Resisting Frame.  
OMRF: Ordinary Moment Resisting Frame.  
NL: No limit.  
H: Height in feet.

Figure 16.  $R_w$  values for Structural Systems in Concrete (UBC 1994)

In the UBC 1994 command inputs, there are several parameters that affect the outcome of the analysis. Soil profile determined which value of site coefficient (S) to be used.

Table 10: Comparison between Static Analysis Results and the Structural Capacities for Side Frame K1

	Maximum Bending Moment at beam 6	Maximum Shear Force at Beam 6	Maximum Axial Force at Column 5
Static Analysis	89.55 kN.m	91 kN	21.4 kN
Structural Capacities	344.36 kN.m	159.82 kN	1190 kN

Beam no 6 in the analysis is equivalent as in section 7-7 described in the structural drawing. From the table, it can be seen that the maximum bending moment experienced by the same beam does not exceed its ultimate moment capacity. Maximum Shear Force at beam 6 also does not exceed its shear force capacity.

Table 11. Comparison between Static Analysis Results and the Structural Capacities for Front Frame K1

	Maximum Bending Moment	Maximum Shear Force	Maximum Axial Force
Static Analysis	16.74 kN.m at node 5 of beam 6	19.45 kN at beam 31	119 kN at column 5
Structural Capacities	163.54 kN.m	145.64 kN	1190 kN

Beam no 6 in the analysis is equivalent as in section 2-2 described in the structural drawing. The maximum bending moment experienced by the same beam does not exceed its ultimate moment capacity. Maximum Shear Force at beam no 31 also does not exceed its shear force capacity. Beam no 31 corresponds to section 1-1 of the detailed structural drawing.

Although, all the maximum values experienced by the beam and column do not exceed its capacity, the trend of where maximum bending moment occurs can be seen. The maximum bending moment always occurred at first floor beam in Side Frame K1. In Front Frame K1, it also occurred at first floor beam, at the left end of the frame.

### Response Spectrum Analysis

In this analysis, El Centro Ground Motion is chosen. Although Malaysia have never experienced earthquake as strong as the El Centro, it is equally important to observe the behavior as precaution matter can be taken if an earthquake or tremor of similar strength were to happen in the future. Also, seismic design can now be taken into design of building in Malaysia. In a response spectrum analysis, the sign of the forces cannot be determined, and hence are absolute numbers. Thus, to account for the fact that the force could be positive or negative, 2 load combination cases are created. In this case, the load cases are load combination no 3 and no 4.

Table 12: Comparison between Response Spectrum Analysis Results and the Structural Capacities for Side Frame K1

	Maximum Bending Moment	Maximum Shear Force	Maximum Axial Force
Response Spectrum Analysis	114.35 kN.m at beam 6	85.81 kN at beam 3	205.36kN at column 1
Structural Capacities	163.54 kN.m	145.64 kN	1190 kN

Table 13. Comparison between Response Spectrum Analysis Results and the Structural Capacities for Front Frame K1

	Maximum Bending Moment	Maximum Shear Force	Maximum Axial Force
Response Spectrum Analysis	23.96 kN.m at beam 6	27.06 kN at beam 34	117.17 kN at column 5
Structural Capacities	163.54 kN.m	145.64 kN	1190 kN

From table x and y, beam no 6 (section 2-2 of detail drawings) experienced maximum bending moment of 114.35 kN.m (Side Frame K1) and 23.96 kN.m (Front Frame K1). Beam no 6 is a first floor beam. However, the maximum shear force in Side Frame K1 occurred at beam 3, which is the second floor beam while in Front Frame K1, the maximum value is at first floor beam. Maximum axial force which occurred at column 1 and column 5 are both ground floor columns.

The difference of maximum values of bending moment, axial force and shear force displayed in Side Frame K1 and Front Frame K1 could be subjected to the direction of the horizontal force produced by seismic motion at a different span of building. Side Frame K1 had a 7.5 m span while the Front Frame had a span of 24 m.

## **CHAPTER 5**

### **CONCLUSION AND RECOMMENDATION**

#### **5.1 Conclusion**

From the results of equivalent static analysis and the dynamic analysis, which are then compared to the structural design capacities of beam and columns, the typical school building in Malaysia does not fail under seismic zone 1 in static analysis and response spectrum analysis using horizontal ground motion acceleration of El Centro earthquake.

#### **5.2 Recommendation**

The accuracy of the results in terms of load applied can be improved by providing the whole building construction material so that an almost alike situation of the real structure can be simulated.

To further continue the static analysis of with other seismic zone, the school building moment resisting frame could be changed to other structural systems. They are Special Moment resisting Frame (SMRF), Intermediate Moment Resisting Frame (IMRF), Building Frame System (shear walls & braced frames), Bearing Wall Systems (shear wall & braced frames) and Dual System (Shear wall + SMRF, Shear walls + IMRF, Braced Frame + SMRF, Braced Frame + IMRF).

## REFERENCE

- i. Xiao, Y. and Martirosyan A. 1998, "Seismic Performance of High-Strength Concrete Column," *Journal of Structural Engineering/ March 1998* : 241-250
- ii. Lu, Y. 2002, "Comparative Study of Seismic Behavior of Multistory Reinforced Concrete Framed Structures," *Journal of Structural Engineering*, February 2002: 69-178
- iii. Lowes, L.N. and Altoontash, A. 2003, "Modeling Reinforced Concrete Beam-Column Joints Subjected to Cyclic Loading," *Journal of Structural Engineering*, December 2003 : 1686- 1696
- iv. Parra-Montesinos, G.J., Perterfreund S.W. and Chao, S.H., 2004, "Highly Damage-Tolerant Beam-Column Joints through Use of High Performance Fiber Reinforced Cement Composites," *ACI Structural Journal*, **102(3)**: 487-495
- v. McCormac, J.C. and Nelson, J.K. 2005. *Design of Reinforced Concrete*. Sixth Edition. John Wiley & Sons, Inc
- vi. Barros, R.C. and Almeida, R. 2004, "Pushover Analysis of Assymetric Three Dimensional Building Frames," *Journal of Civil Engineering And Management 2005* **11(1)**: 3-12
- vii. Proença, J., Oliveira C. S. and Almeida J.P., 2004, "SEISMIC PERFORMANCE ASSESSMENT OF REINFORCED CONCRETE STRUCTURES WITH MASONRY INFILLED PANELS: THECASE OF BLOCK # 22 OF THE SANTA MARIA HOSPITAL IN LISBON," *ISET Journal of Earthquake Technology*, **41(2-4)**: 233-247
- viii. Kappos, A.J. and Panagopoulos, G. 2004, "Performance Based Seismic Design of 3D R/C Buildings Using Inelastic Static and Dynamic Analysis Procedures" *ISET Journal of Earthquake Technology*, Paper 441, **41(1)**: 141-158
- ix. Griffith, M.C. 2003). "EARTHQUAKE ENGINEERING IN AUSTRALIA - International Collaborations and Future Directions"



- x. Kunnath, S.K., Valles-Mattox, R.E. and Reinhorn, A.M., 1996, "EVALUATION OF SEISMIC DAMAGEABILITY OF A TYPICAL R/C BUILDING IN MIDWEST UNITED STATES" *Eleventh World Conference in Earthquake Engineering (11WCEE) Acapulco, Mexico,*"
- xi. Drdácý, M. and Pospíšil S., 2005, "Earthquake Resistance of Structures and Dynamic Response Using Large Facilities Experiments"
- xii. Chopra A.K. 1997 *Dynamics of Structures: Theory and Applications to Earthquake Engineering*, Prentice Hall International Inc

## APPENDIX A: DEAD LOADS AND LIVE LOADS USED IN REPORT

**Table 1.2** Weights of Some Common Building Materials

Reinforced concrete—12 in.	150 psf	2 × 12 @ 16-in. double wood floor	7 psf
Acoustical ceiling tile	1 psf	Linoleum or asphalt tile	1 psf
Suspended ceiling	2 psf	Hardwood flooring ( $\frac{7}{8}$ -in.)	4 psf
Plaster on concrete	5 psf	1-in. cement on stone-concrete fill	32 psf
Asphalt shingles	2 psf	Movable steel partitions	4 psf
3-ply ready roofing	1 psf	Wood studs w/ $\frac{1}{2}$ -in. gypsum	8 psf
Mechanical duct allowance	4 psf	Clay brick wythes—4 in.	39 psf

**Table 1.3** Some Typical Uniformly Distributed Live Loads

Lobbies of assembly areas	100 psf	Classrooms in schools	40 psf
Dance hall and ballrooms	100 psf	Upper-floor corridors in schools	80 psf
Library reading rooms	60 psf	Stairs and exitways	100 psf
Library stack rooms	150 psf	Heavy storage warehouse	250 psf
Light manufacturing	125 psf	Retail stores—first floor	100 psf
Offices in office buildings	50 psf	Retail stores—upper floors	75 psf
Residential dwelling areas	40 psf	Walkways and elevated platforms	60 psf

<sup>19</sup>American Society of Civil Engineers, 2002, *Minimum Design Loads for Buildings and Other Structures*, ASCE 7-02 (Reston, VA: American Society of Civil Engineers), pp. 12–15.

## APPENDIX B: FORMULAS USED IN STRUCTURAL CAPACITIES

### *Formulas*

Formulas involved in calculation of beam and column capacities using ACI Code  
Beams

#### 1. Ultimate Moment Strength, $M_n$

- $M_n = T (d-a/2)$  (unit: kN.m)
  - Tension,  $T = A_s f_y$
  - Compression,  $C = 0.85 f'_c a b$
  - $a$  is obtained from equation when  $T = C$  (equilibrium)

#### • T- Beams

$$\phi M_n = \phi T z \text{ (unit: kN.m)}$$

- Tension,  $T = A_s f_y$
- Area of concrete in compression,  $A_c = T / 0.85 f'_c$
- $a = A_c / b_w$ ;  $b_w$  is the effective width
- $z = d - a/2$
- Reduction factor,  $\phi = 0.90$

#### 2. Shear, $V_u$

- $V_u = \phi V_c + \phi V_s$  (unit: kN)
  - $V_c = (\sqrt{f'_c} / 6) b_w d$  (In SI)
  - $V_s = \frac{1}{3} \sqrt{f'_c} b_w d$  (In SI)
  - $A_v = \frac{\phi \sqrt{f'_c}}{12} \frac{A_{cp}^2}{p_{cp}}$
  - $\phi = 0.75$

#### 3. Torsion, $T_u$

- $T_u = \frac{\phi \sqrt{f'_c}}{12} (A_{cp}^2 / p_{cp})$  (unit : kN.m)
  - $A_{cp}$  = area enclosed by outside perimeter concrete cross-section

- $p_{cp}$  = perimeter (outside) of beam cross-section

#### 4. Development Length

It can be defined as the minimum length of embedment of bars that is necessary to permit them to be stressed to their yield point plus some extra distance to ensure member toughness. The bar stresses must be transferred to the concrete by bond between the steel and the concrete before the bars can be cut off.

$$\bullet \frac{l_d}{d_b} = \frac{9}{10} \frac{f_y \alpha \beta \gamma \lambda}{\sqrt{f'_c} (c + K_{tr})} \quad (\text{unit: diameters})$$

- $\alpha$  = reinforcement location factor (table 7.1; ACI 12.2.4)
- $\beta$  = coating factor (table 7.1; ACI 12.2.4)
- $\gamma$  = reinforcement size factor (table 7.1; ACO 12.2.4)
- $C$  = lightweight aggregate concrete factor (table 7.1; ACI 12.2.4)

<i><math>\alpha</math> (alpha) = reinforcement location factor</i>	
Horizontal reinforcement so placed that more than 12 in. of fresh concrete is cast in the member below the development length or slice	1.3
Other reinforcement	1.0
<i><math>\beta</math> (beta) = coating factor</i>	
Epoxy-coated bars or wires with cover less than $3d_b$ or clear spacing less than $6d_b$	1.5
All other epoxy-coated bars or wires	1.2
Uncoated reinforcement	1.0
<i>However, the product of <math>\alpha \beta</math> need not be taken greater than 1.7</i>	
<i><math>\gamma</math> (gamma) = reinforcement size factor</i>	
No. 6 and smaller bars and deformed wires	0.8
No. 7 and larger bars	1.0
In SI units,	

No.19 and smaller bars and deformed wires	0.8
No. 22 and larger bars	1.0
<i><math>\gamma</math> (lambda)= lightweight aggregate concrete factor</i>	
When lightweight aggregate concrete is used	1.3
However, when $f_{ct}$ is specified, $\gamma$ shall be permitted to be taken as $6.7 \sqrt{f'_c} / f_{ct}$	1.0
Its $\sqrt{f'_c} / 1.8f_{ct}$ in SI, but not less than	1.0
When normal weight concrete is used	1.0
<i><math>c</math> = spacing or cover dimension</i>	
Use the smaller of either the distance from center of the bar or wire to the nearest concrete surface, or one-half the center-to-center spacing of the bars or wires being developed	

Table 1 –Factors for Use in the Expressions for Determining Required Development Lengths for Deformed Bars and Deformed Wires in Tension (ACI 12.2.4)

- $K_{tr}$  = transverse reinforcement index;
  - $K_{tr} = 0$ , permitted by ACI Code in Section 12.2.4
  - Computed  $K_{tr} = \frac{A_{tr} f_{yt}}{10sn}$  ( In SI units)
    - $A_{tr}$  = total cross-section area of all transverse reinforcement having the center-to-center spacing  $s$  and a yield strength  $f_{yt}$
    - $n$  = number of bars being developed along the lane of splitting

## Columns

### 1. Axial Load Capacity, $P_u$

- $P_u = \phi P_n = 0.80\phi [ 0.85f'_c (A_g - A_{st}) + f_y A_{st} ]$  (unit: kN) ;  $\phi$  value as specified in Section 9.3.2 of the Code; 0.7 for tied columns

### 2. Shear

- $V_c = 1 + \frac{N_u}{14A_g} * \frac{\sqrt{f'_c} * b_w * d}{6}$  (unit: kN)

Table 2: Areas of Groups of Standard Metric Bars (mm<sup>2</sup>) ( $A_{st}$ )

Bar Designation	Number of bars								
	2	3	4	5	6	7	8	9	10
#10	142	213	284	355	426	497	568	639	710
#13	258	387	516	645	774	903	1032	1161	1290
#16	398	597	796	995	1194	1393	1592	1791	1990
#19	568	852	1136	1420	1704	1988	2272	2556	2840
#22	774	1161	1548	1935	2322	2709	3096	3483	3870
#25	1020	1530	2040	2550	3050	3570	4080	4590	5100
#29	1290	1935	2580	3225	3870	4515	5160	5805	6450
#32	1638	2457	3276	4095	4914	5733	6552	7371	8190
#36	2012	3018	4024	5030	6036	7042	8048	9054	10060
#43	2904	4356	5808	7260	8712	10162	11616	13068	14520
#57	5162	7743	10324	12905	15486	18067	20648	23229	25810

Table 2 (Continued)

Bar Designation	Number of bars									
	11	12	13	14	15	16	17	18	19	20
#10	781	852	923	994	1065	1136	1207	1278	1349	1420
#13	1419	1548	1677	1806	1935	2064	2193	2322	2451	2580
#16	2189	2388	2587	2786	2985	3184	3383	3582	3781	3980
#19	3124	3408	3692	3976	4260	4544	4828	5112	5396	5680
#22	4257	4644	5031	5418	5805	6192	6579	6966	7353	7740
#25	5610	6120	6630	7140	7650	8160	8670	9180	9690	10200
#29	7095	7740	8385	9030	9675	10320	10965	11610	12255	12900
#32	9009	9828	10647	11466	12285	13104	13913	14742	15561	16380
#36	11066	12072	13078	14084	15090	16096	17102	18108	19114	20120

#43	15972	17424	18876	20328	21780	22232	24684	26136	27588	29040
#57	28391	30972	33553	36134	38715	41296	43877	46458	49039	51620

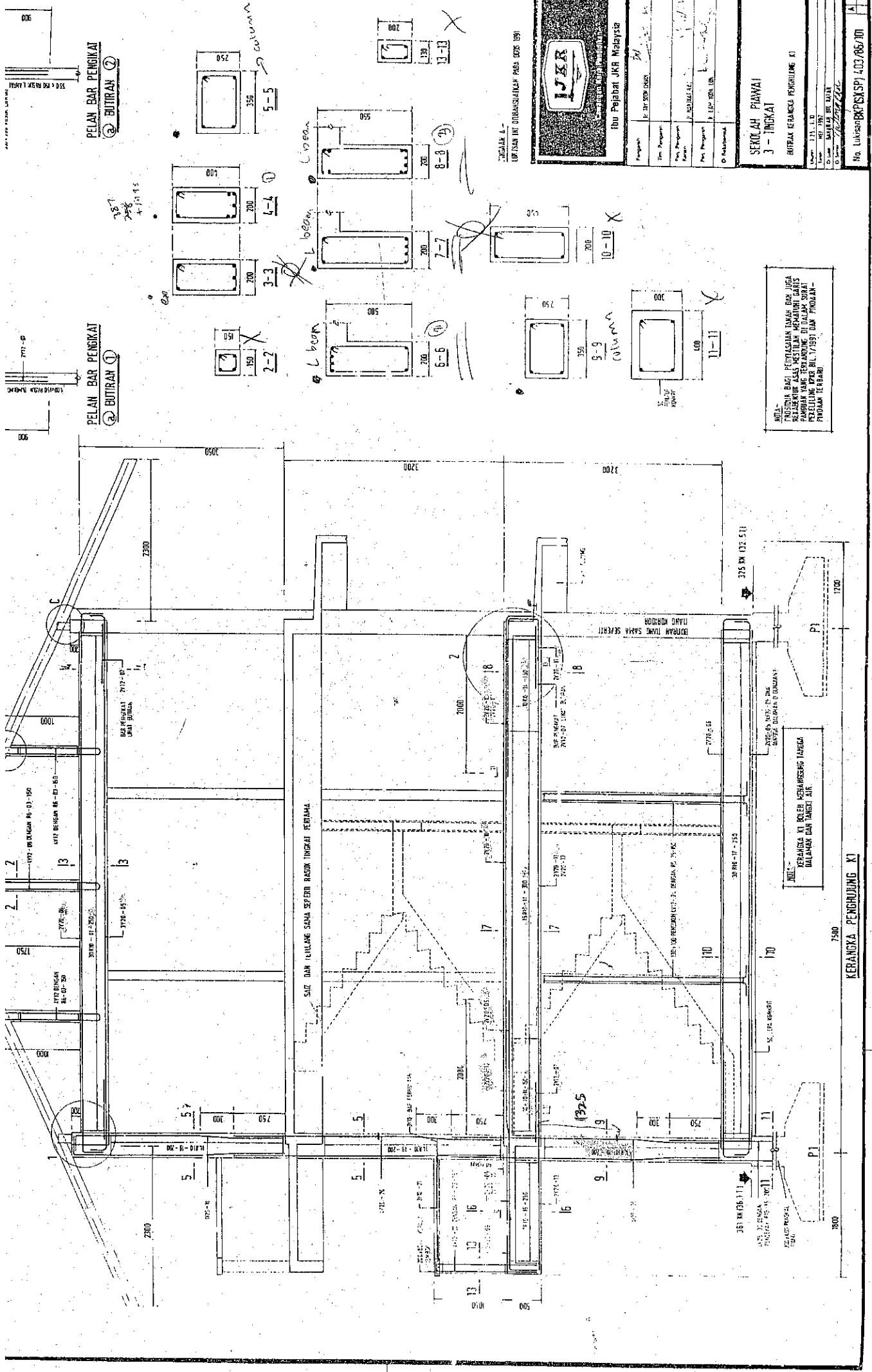

PELAN BAR PENGKAI  
BUTIRAN 2

PELAN BAR PENGKAI  
BUTIRAN 1

REKAH A-  
DIPUNJUK OMBUDSMAN PADA OKT 1991

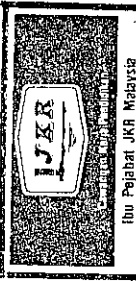

Program	JKR 1000/1000
Tm. Program	JKR 1000/1000
Ang. Program	JKR 1000/1000
Proj. Program	JKR 1000/1000
D. Rekastruktur	JKR 1000/1000

SEKOLAH PIAWAI  
3 - IMBOKAI  
BUTIRAN KERANGKA PENYUNTING K1

NO. 11/13  
NO. 11/13  
NO. 11/13  
NO. 11/13  
NO. 11/13

No. Lukisan/BK/SM/SP/403/88/10

NOTA:  
PROSEDUR BAGI PEMASIHAN TAJUK DAN JUKA  
RELEKTRIK ASAS MESTILAH MEMADUKI LARIS  
KONTRAK DAN BERKAWANG DI DALAM SURAT  
KONTRAK DAN BERKAWANG DI DALAM SURAT  
PROGRAM TERSEBUT.

KERANGKA PENYUNTING K1



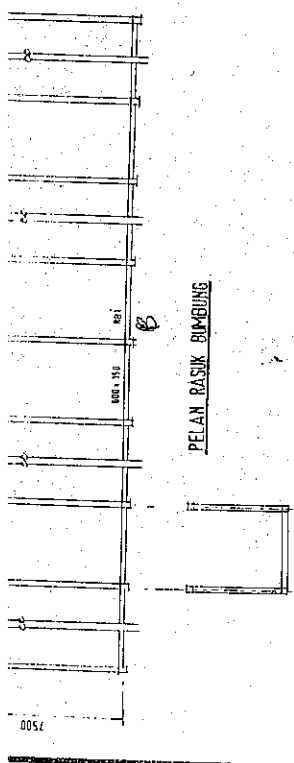

PELAN BASIK BUMBUNG

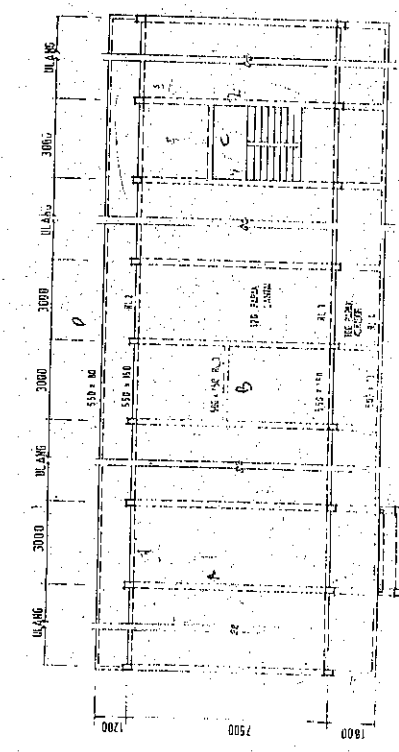

PELAN LANTAI TIPIKAL

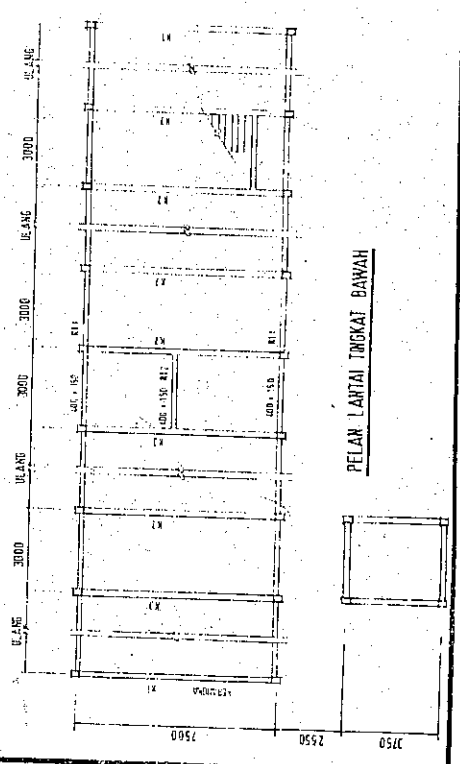

PELAN LANTAI TINGKAT BAWAH

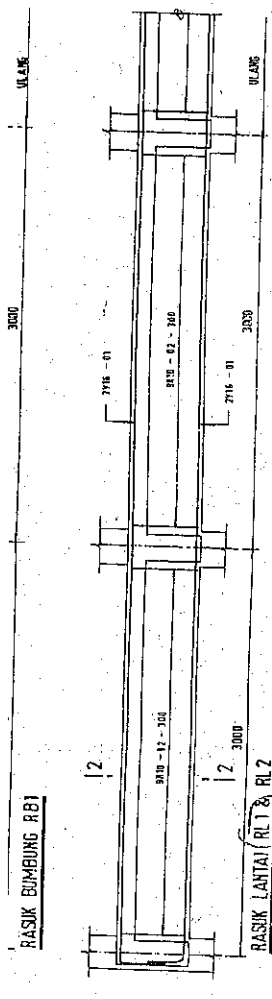

RASIK BUMBUNG RB1

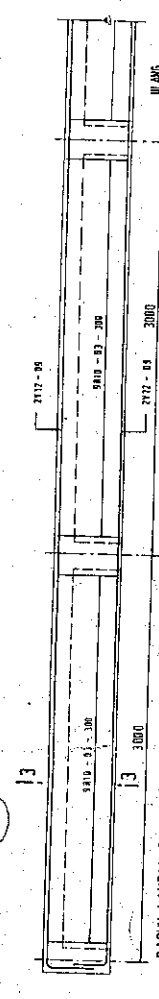

RASIK LANTAI RLT & RLT2

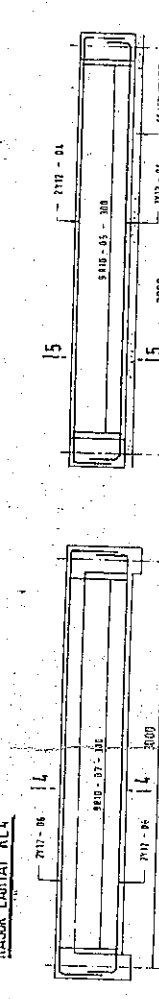

RASIK LANTAI RL4



RASIK TINGKAT BAWAH RL3

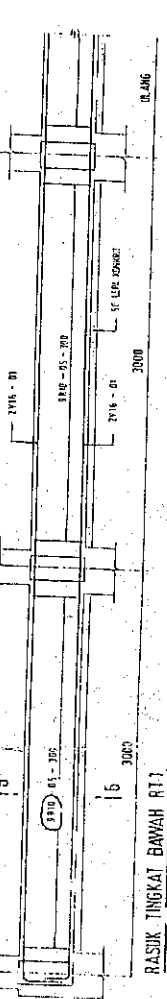

RASIK TINGKAT BAWAH RL1

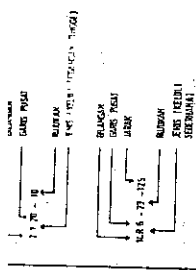

RASIK BUMBUNG RB1

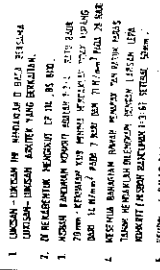

RASIK LANTAI RLT & RLT2

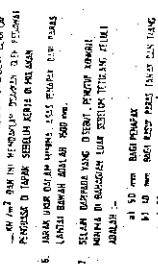

RASIK LANTAI RL4

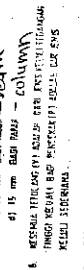

RASIK TINGKAT BAWAH RL3

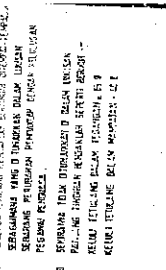

RASIK TINGKAT BAWAH RL1

MUDA

1. URAIAN, URAIAN, DAN HARGA DARI BAHAN-BAHAN YANG TERDIRI DARI RENCANA.
2. DAFTAR PERALATAN YANG TERDIRI DARI RENCANA.
3. KOSUR PERALATAN YANG TERDIRI DARI RENCANA.
4. KOSUR PERALATAN YANG TERDIRI DARI RENCANA.
5. KOSUR PERALATAN YANG TERDIRI DARI RENCANA.
6. KOSUR PERALATAN YANG TERDIRI DARI RENCANA.
7. SELAIN PERALATAN YANG TERDIRI DARI RENCANA.
8. KOSUR PERALATAN YANG TERDIRI DARI RENCANA.
9. KOSUR PERALATAN YANG TERDIRI DARI RENCANA.
10. KOSUR PERALATAN YANG TERDIRI DARI RENCANA.

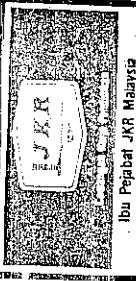

Pejabat	1. JKR SPP-DRAF
Tua Pejabat	2. JKR SPP-DRAF
Pia Pejabat	3. JKR SPP-DRAF
Ketua	4. JKR SPP-DRAF
Pejabat	5. JKR SPP-DRAF

SEKOLAH PIAWAI	
PELAN LANTAI BAK	
BOTAN BASUK	
NO. LUKISAN	BKPI/SPI/1007/86/101

# APPENDIX D: EL CENTRO, 1940 EARTHQUAKE GROUND MOTIONS

EL CENTRO EARTHQUAKE MAY 18, 1940  
NORTH-SOUTH COMPONENT

