

**Effect of Energy Recovery on the Hoisting Crane Adapting Closed Loop  
Hydraulic Hoisting System**

by

**Ahmad Hasnulnaim Bin Che Kamaruddin**

Dissertation submitted in partial fulfillment of  
the requirement for the  
Bachelor of Engineering (Hons)  
(Mechanical Engineering)

SEPTEMBER 2011

Universiti Teknologi PETRONAS  
Bandar Seri Iskandar  
31750 Tronoh  
Perak Darul Ridzuan

CERTIFICATION OF APPROVAL

**Effect of Energy Recovery on the Hoisting Crane Adapting Closed Loop  
Hydraulic Hoisting System**

by

Ahmad Hasnulnaim Bin Che Kamaruddin

A project dissertation submitted to the  
Mechanical Engineering Programme  
Universiti Teknologi PETRONAS  
In partial fulfillment of the requirement for the  
BACHELOR OF ENGINEERING (Hons)  
(MECHANICAL ENGINEERING)

Approved by,

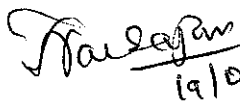
  
19/01/2012

(Prof. Dr. Nagarajan Thirumalaiswamy)

UNIVERSITI TEKNOLOGI PETRONAS

TRONOH, PERAK

September 2011

## CERTIFICATION OF ORIGINALITY

This is to certify that I am responsible for the work submitted in this project, that the original work is my own except as specified in the references and acknowledgements, and that the original work contained herein have not been undertaken or done by unspecified sources or persons.

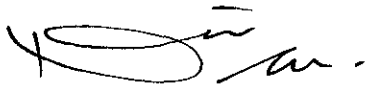

---

AHMAD HASNULNAIM BIN CHE KAMARUDDIN

## ABSTRACT

The purpose of this project is to research and study the effect of energy recovery from closed loop hydraulic hoisting system. The project is specifically involving various types of hoisting cranes such as tower cranes, crawler cranes and offshore cranes. In some cases, closed loop hydraulic hoisting circuit is said to have pump 'back driving' during lowering the load. The winch is the spool of the crane and its function is to adjust the tension of the wire rope, on in the case of lowering load, to let out the tension of wire rope so the load will be lowered. But, when the load is of sufficient weight, the hydraulic motor at the winch will behave like a hydraulic pump instead of pushing flow back to the actual hydraulic pump. This phenomenon is what needed to be study and find if there will be some effect to the prime mover (for example diesel motor and electric motor). However, the solution for this problem is said to be introducing a heat loading in the system. Heat loading means is to maintain a power resistance so that there will be a countering effect equivalent to the lowering power generated by the hydraulic motor at the winch. Energy recovery methods are essential so that crane system can recover and reutilize energy, save pump supply energy and improve energy utilization of the crane system. To conduct this project, a method of using the assistant systems and ELS system will be used to recover the energy that was wasted during the crane operation. Thus, the effect on the equipments that are involved in inducing back driving phenomenon will be determine.

## ACKNOWLEDGEMENTS

The author wishes to take the opportunity to express utmost gratitude to Allah the Almighty upon the completion of this Final Year Project. Without His love and mercy, it is impossible to do anything related to this project.

A special thanks to respectable supervisor, Prof. Dr. Nagarajan Thirumalaiswamy for the opportunity given to the author to accomplish this project under his supervision. Also the same greeting goes to Dr. Tadimalla Varaha Venkata Lakshmi Narasimha Rao, as co – supervisor for this project. Attention, patience and knowledge shared by them had been really helpful in ensuring a steady progress of this project.

A very special thanks goes to the Final Year Project Coordinator, Dr. Mohd Faizairi bin Mohd Nor for providing the author with all initial information required to perform the project.

Not to be forgotten, the author also want to express his gratitude towards the technicians in Mechanical Engineering department, Mr Irwan bin Othman, Mr Mohd Shairul bin Harun, Mr Jani bin Alang Ahmad and Mr Shaiful Hisham bin Samsudin for assisting the author in using the required laboratory facilities.

Last but not least, a very deepest thanks to family and friends for their love and support to the author throughout this project.

## TABLE OF CONTENTS

TABLE OF CONTENTS.....	2
ABSTRACT.....	3
LIST OF FIGURES .....	4
1.0 INTRODUCTION .....	5
1.1 Background of Study .....	5
1.2 Problem Statement .....	6
1.2.1 Problem Identification.....	6
1.2.2 Significance of Project .....	6
1.3 Objective and Scope of the Project.....	6
1.3.1 Objectives.....	6
1.3.2 Scope of the Project .....	7
1.4 Relevancy of Project .....	7
2.0 THEORY & LITERATURE REVIEW .....	8
3.0 METHODOLOGY.....	17
4.0 RESULT AND DISCUSSION .....	26
5.0 CONCLUSION.....	39
6.0 RECOMMENDATION.....	39
REFERENCE.....	40

## **LIST OF FIGURES**

Figure 1: Crawler crane

Figure 2: Crane load diagram

Figure 3: Pascal Law

Figure 4: Reservoir piping

Figure 5: Reservoir

Figure 6: Basic Operation of Hydraulic Motor

Figure 7: Reciprocating type pump

Figure 8: Positive Displacement Pump

Figure 9: Non-positive displacement pump

Figure 10: Gear pump

Figure 11: Basic Hydraulic Circuit in Mobile Crane

Figure 12: Hydraulic Circuit for Ram Luffing Crane

Figure 13: Project Flowchart

Figure 14: Gantt chart of the project.

Figure 15: Key Milestone

Figure 16: Main system and assistant system

Figure 17: Example of hydraulic crane

Figure 18: Gear Pump

## **1.0 INTRODUCTION**

This introduction parts of this draft will basically includes about the introduction to this project, and followed with background of study, problem statement, objective, and scope of study.

### **1.1 Background of study.**

Although one may not familiar with hoists and cranes, but they are practically, lifting equipments. Construction industries use different kinds of hoists and cranes everyday to alleviate the burden in lifting heavy materials. By using these special equipments, their lifting tasks will be finished effortlessly and tremendously saving time and energy.

A hoist is a helpful device that is used for lifting and lowering loads. This is usually done by means of a barrel or a drum where a chain or a rope can be wrapped around. A hoist can be manually or electrically operated, it can also be pneumatically driven using a chain and wire or fiber rope as lifting medium. Cranes are used commonly in construction or manufacturing industry. These are temporary structures, and is either fixed or mounted. Cranes are usually operator-controlled and some of them are operated by using a push-button control-station or a radio/infrared remote control. [1]

Hoists and cranes are very great aids in safe and efficient lifting or in material-handling operations. Hoists and cranes are properly engineered for a powerful, reliable and efficient operation. This project however will study about a weakness of the hoisting system during lowering the load which causes the hydraulic motor on the winch to act like hydraulic pump and induce the problem of lowering the load.



## **1.2 Problem Statement**

### **1.2.1 Problem Identification**

Closed loop hydraulic hoisting circuit is said to have pump back driving during load lowering. If the load is of sufficient weight, the hydraulic motor at the winch will behave like a hydraulic pump instead pushing flow back to the actual hydraulic pump. What effect will there be to the prime mover if this phenomenon does exist? One remedy seems to be introducing a heat loading in the system to maintain a power resistance so that there will be a countering effect equivalent to the lowering power generated. Does this really work? And what is the energy recovery method that can be applied to recover the excess power induced to prime mover?

### **1.2.2 Significance of the project**

This project would give an opportunity to the engineering students to explore about the possibilities of energy recovery of the crane during the operation and the effect of the back driving to the prime mover. The energy can be recovered by the assistant system and then be released into the system as regenerated energy. This project will cause a considerable additional reduction in hydraulic pump supply energy and work losses in the system for the same work situation. Therefore, the energy utilization in the hydraulic crane can be greatly improved. By enhancing the energy recovery system, it can contribute to the commercial application in other lifting machineries. [3]

## **1.3 Objective and Scope of Study**

### **1.3.1 Objective**

- To find the matters contributed in recovery the energy of the system in hoisting crane system.
- To calculate and measures the effect of energy recovery on the related equipments that responsible of inducing back driving phenomenon.
- To study the solution of back driving by introducing the heat loading into the system.

### **1.3.2 Scope of Study**

Scope of study for this project is involving the research and to conduct the experiments on the hoisting crane system. The purpose is to find the energy recovery methods for the hoisting crane during the operation so that the redundant energy will be released back into the system instead of being wasted.

### **1.4 Relevancy of the project**

By learning and conducting the experiments on the hoisting cranes, the students will be able to understand thoroughly about how the hydraulic hoisting cranes works and also the importance of recovery the energy. This will create the awareness of not wasting the energy that being produced but instead to try to conserve the energy for better usage. The problem of back driving effect on prime mover also will encourage the students to find the perfect solution by means to encounter the problem. This project is perfect for the student aiming to become an engineer because with the problem given the students will learn the hard way on accomplishing something while solving the matter.

## 2.0 THEORY & LITERATURE REVIEW

This literature review discusses about the theories and paperwork reviews related to this project.

### 2.1 Hoisting Crane

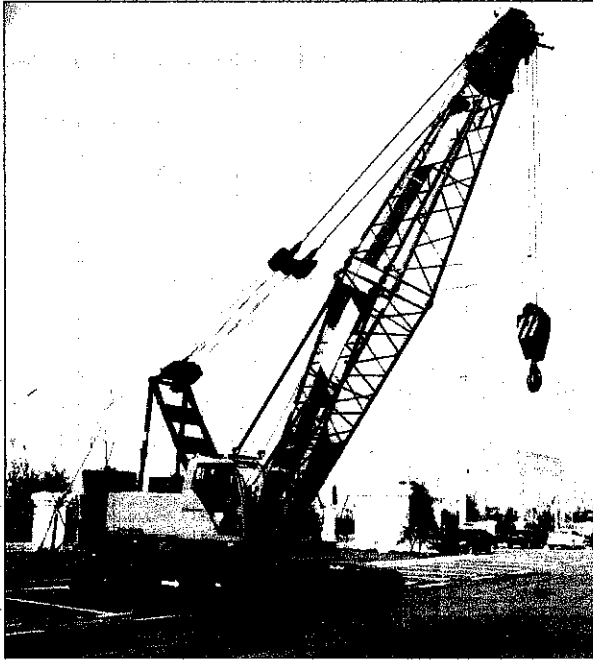

Figure 1: Crawler crane [2]

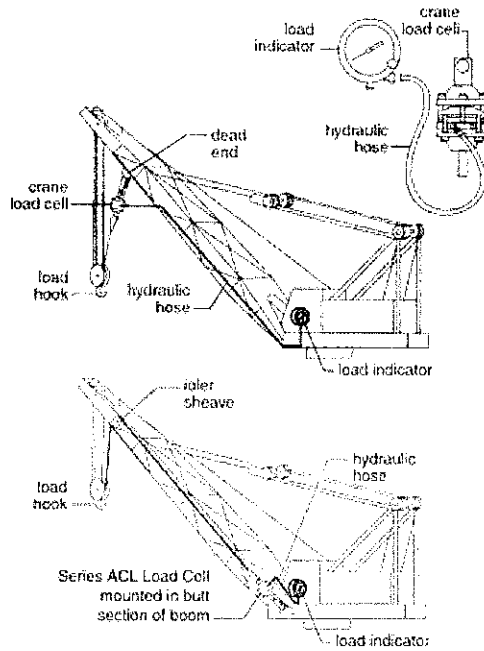

Figure 2: Crane load diagram [2]

A hoisting crane is perfectly built for pulling or lifting devices and heavy materials, which makes use of a line in order to move heavy equipment. Its technology is improving, thus, giving people more innovation and convenience. A hoisting crane manufacturer is particular when it comes to designing them. [2]

The first hoisting cranes that were built were typical but as the need for advanced lifting devices grows, manufacturers have come up with different types of units made for different purposes. They have increased the specifications of the units to make sure that lifting heavy equipments are done properly. Engineers have claimed that with the help of these lifting units, their work is made efficient and well organized. [2]

Examples of hoisting crane are tower crane, crawler crane, offshore crane, wharf crane and loader crane.

## 2.2 Hydraulic System

Hydraulic system is a system designed to transmit power through a liquid medium, permitting multiplication of force in accordance with Pascal's law, which states that "a pressure exerted on a confined liquid is transmitted undiminished in all directions and acts with equal force on all equal areas." Hydraulic systems have six basic components: (1) a reservoir to hold the fluid supply; (2) a fluid to transmit power; (3) a pump to move the fluid; (4) a valve to regulate the pressure; (5) a directional valve to control the flow, and (6) a working component, such as a cylinder and piston or a shaft rotated by pressurized fluid, to turn hydraulic power into mechanical systems: they eliminate complicated mechanisms such as cams, gears, and levers; are less subject to wear; are usually more easily adjusted from control of speed and force; are easily adaptable to both rotary and linear transmission of power; and can transmit power over long distances and in any direction with small losses.

The advantages of hydraulic systems over other methods of power transmission are:

- **Simpler design.** In most cases, a few pre-engineered components will replace complicated mechanical linkages.
- **Flexibility.** Hydraulic components can be located with considerable flexibility. Pipes and hoses instead of mechanical elements virtually eliminate location problems.
- **Smoothness.** Hydraulic systems are smooth and quiet in operation. Vibration is kept to a minimum.
- **Control.** Control of a wide range of speed and forces is easily possible.
- **Cost.** High efficiency with minimum friction loss keeps the cost of a power transmission at a minimum.
- **Overload protection.** Automatic valves guard the system against a breakdown from overloading.

The main disadvantage of a hydraulic system is maintaining the precision parts when they are exposed to bad climates and dirty atmospheres. Protection against rust, corrosion, dirt, oil deterioration, and other adverse environmental conditions is very important.

### 2.2.1 Basic Hydraulic

#### Pressure and Force

Pressure is force exerted against a specific area (force per unit area) expressed in pounds per square inch (psi). Pressure can cause an expansion, or resistance to compression, of a fluid that is being squeezed. A fluid is any liquid or gas (vapour). Force is anything that tends to produce or modify (push or pull) motion and is expressed in pounds.

The relationship of force, pressure, and area is as follows:

$$P = \frac{F}{A}$$

Where:

F = force, in Newton (N)

P = pressure, in Pascal (Pa)

A = area, in mm<sup>2</sup>

#### Pascal's Law

Blaise Pascal formulated the basic law of hydraulics in the mid 17th century. He discovered that pressure exerted on a fluid acts equally in all directions. His law states that pressure in a confined fluid is transmitted undiminished in every direction and acts with equal force on equal areas and at right angles to a container's walls.

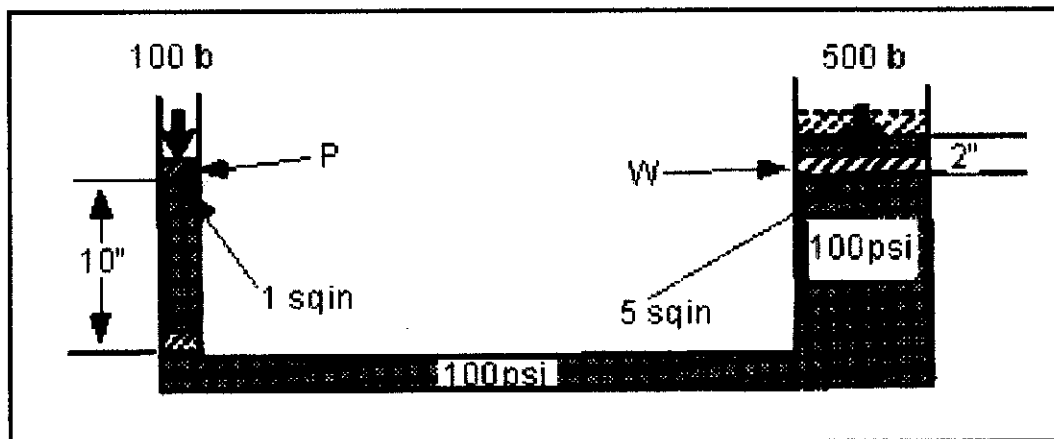

Figure 3: Pascal Law

$$F1 \times D1 = F2 \times D2$$

Where:

F1 = force of the small piston, in Newton (N)

D1 = distance the small piston moves, in meter (M)

D2 = distance the larger piston moves, in meter (M)

F2 = force of the larger piston, in Newton (N)

### **Open Loop and Close Loop Hydraulic circuit**

**Open Loop System** - Pump-inlet and motor-return (via the directional valve) are connected to the hydraulic tank.

Open Loop systems drawn fluid from a reservoir and push the fluid into and through the hydraulic system. After passing through directional control valves, drive motors and other ancillary components the fluid is returned to the reservoir.

A reservoir supporting an open loop hydraulic system should be sized so that it will hold a minimum of three times the total volume of oil capable of being displaced by all system pumps in one minute and be designed to maximize the time the oil spends in the reservoir (dwell time). This is accomplished by returning the oil to the opposite side of the reservoir from the suction and through the use of baffle(s). Inadequate reservoir design can cause overheating of the hydraulic system and premature component failure.

Pumps used in open loop system can only pump oil in one direction, hence the need for directional control valve. The most popular advantage for which open loop systems are selected is the ability to perform more than one function simultaneously with one pump. This is usually accomplished through the use of multi-section gear pumps and provides a very simple and compact prime mover package. Generally, this arrangement is limited to cranes with relatively low line speed and lifting capacity performance with an intermittent duty cycle requirements. This design was tried by some (American) offshore crane manufacture on larger cranes in high duty cycle applications such as semi submersible drilling rigs but proved to be unreliable and yielded extremely short pump life.

***Close Loop System*** - Motor-return is connected directly to the pump-inlet.

Closed loop systems use a single pump to drive a single function. Oil passing through the hoist motors is returned directly to the low-pressure side of the pump. To properly operate, the pump must receive the same amount of oil at its inlet as it is pumping from its outlet. Closed circuit system always utilize a smaller supercharge or “boost” circuit consisting of small fixed displacement pump which, in addition acting as a hydraulic source for the control circuit, continuously feeds a portion (usually about 15% of the main pump capacity) through an oil cooler and the main hydraulic reservoir. Unlike the intermittent cooling effort of the open loop system, this configuration provides continuous oil cooling and filtration.

When in operation, the pump control can be activated such that the pump can be causing its displacement to move in a clockwise or counter-clockwise direction through the closed loop circuit. This, in turn will allow the drive motor to rotate in either a clockwise or counter clockwise direction and in the case of an offshore crane will either raise or lower the load (or boom). The pump port providing high-pressure leg while the low-pressure leg routes the motor’s outlet back to the pump. The boost system always work on the low-pressure leg of the main loop continuously bleeding-off oil through a hot oil bleed-off valve, pumping the oil through an oil cooler and subsequently returning the filtered and cooled oil back into the system.

Basically, the closed loop system is more efficient, requires fewer components, less oil storage and provides a higher degree of control and adaptability to ancillary systems such as wave compensation system and emergency release devices due the lack of the motor control valve.

## 2.3 Hydraulic Components

### 2.3.1 Actuator

An actuator is a device that converts the energy of hydraulic oil pressure into straight line or rotational motion. They are like the muscles of the arms and legs in the human body. Hydraulic cylinders and hydraulic motors are actuators. Hydraulic cylinders create linear motion while hydraulic motor create rotary motion.

### 2.3.2 Hydraulic fluid

Hydraulic fluid is fluid serving as the power transmission medium in a hydraulic system. The most commonly used fluids are petroleum oils, synthetic lubricants, oil-water emulsions, and water-glycol mixtures. The principal requirements of a premium hydraulic fluid are proper viscosity, high viscosity index, anti-wear protection (if needed), good oxidation stability, adequate pour point, good *demulsibility*, rust inhibition, resistance to foaming, and compatibility with seal materials. Anti-wear oils are frequently used in compact, high pressure, and capacity pumps that require extra lubrication protection.

\* *demulsibility* = The ability of a fluid that is insoluble in water to separate from water with which it may be mixed in the form of an emulsion.



### 2.3.3 Reservoir

The hydraulic reservoir is the fluid storehouse for the hydraulic system. It contains enough fluid to supply the normal operating needs of the hydraulic system and an additional supply to replace fluid lost through minor leaks.

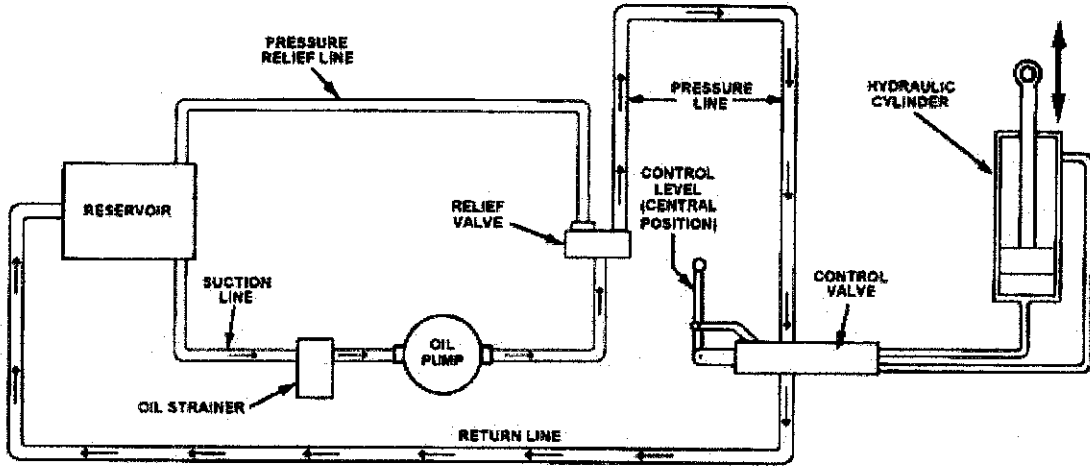

Figure 4: Reservoir piping

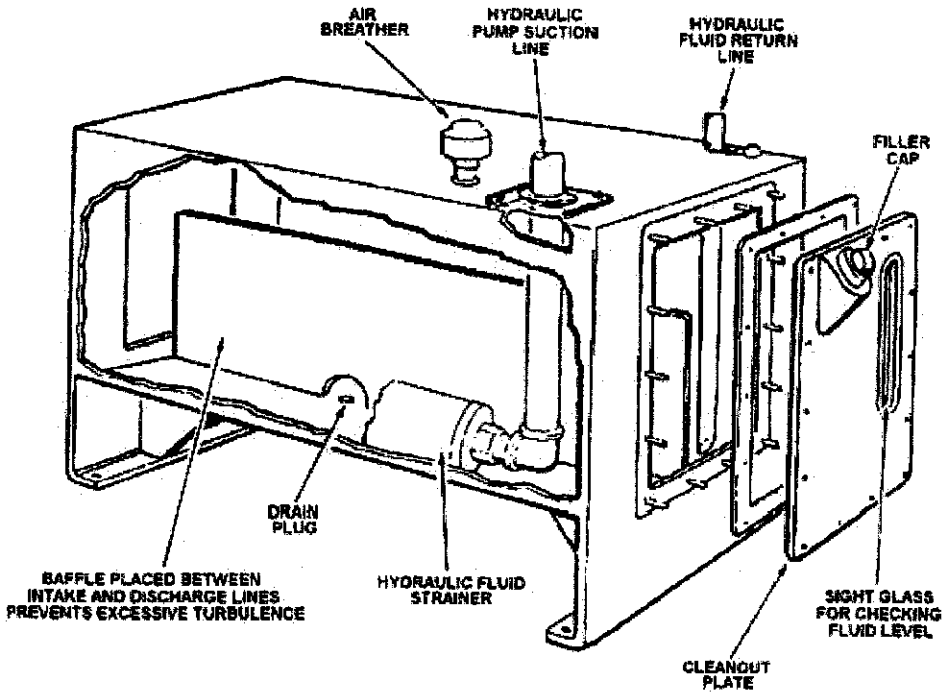

Figure 5: Reservoir

The basic hydraulic reservoir has a space above the fluid even when they are full. This space allows the fluids to foam, and thus purges itself of air bubbles that normally occur as the fluid flows from the reservoir, through the system, and back to the reservoir. The air vent allows the air to be drawn in and pushed out of the reservoir by the ever-changing fluid level. An air filter is attached to the air vent to prevent drawing atmospheric dust into the system. The reservoir or tank performs a number of functions in the hydraulic system:

- Fluid storage
- Separation of air
- Dissipation of heat
- Settling of contaminants

#### **2.3.4 Hydraulic Motor - (converts the energy of pressure into rotational motion)**

A hydraulic motor can in fact be a rotating hydraulic motor as well as a linear hydraulic motor (cylinder). In fact a hydraulic motor is more or less identical to a hydraulic pump. The main difference is that a hydraulic motor is designed for the working pressure at both sides of the motor, like a hydraulic pump for a closed loop system.

#### **Operation**

The hydraulic motor provides power to winches on cranes, drives conveyors on ditching machines, and is used in other applications where mechanical drives are impractical.

In industrial hydraulic circuits, pumps and motors are normally combined with a proper valving and piping to form a hydraulic-powered transmission. A pump, which is mechanically linked to a prime mover, draws fluid from a reservoir and forces it to a motor. A motor, which is mechanically linked to the workload, is actuated by this flow so that motion or torque, or both, are conveyed to the work.

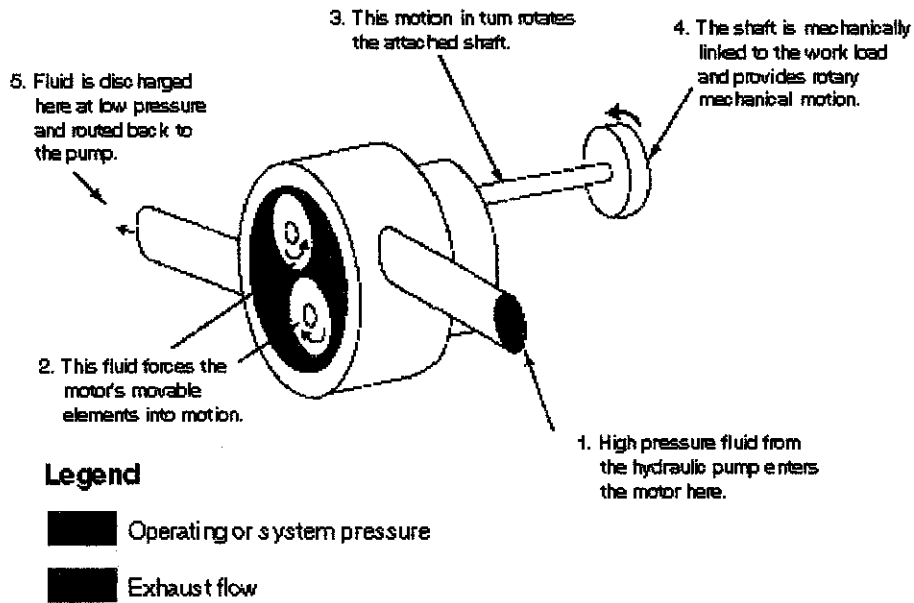

Figure 6: Basic Operation of Hydraulic Motor

The principal ratings of a motor are torque, pressure, and displacement. Torque and pressure ratings indicate how much load a motor can handle. Displacement indicates how much flow is required for a specified drive speed and is expressed in cubic inches per revolutions, the same as pump displacement. Displacement is the amount of oil that must be pumped into a motor to turn it one revolution. Most motors are fixed-displacement; however, variable displacement piston motors are in use, mainly in hydrostatic drives. (Most motors designed for mobile equipment are reversible.) The main types of motors are gear, vane, and piston. They can be unidirectional or reversible.

### **2.3.5 Hydraulic Pump**

Hydraulic pump converts mechanical energy (torque, speed) into hydraulic energy (flow, pressure). Hydraulic pumps are positive displacement pumps, which mean that the flow is directly related to the displacement (per revolution) of the pump and the speed of the pump. Depending on the required flow and pressure, but also related to the required efficiency and life time expectancy, simple (low budget) pumps or high quality pumps are used. Simple, low budget pumps have in general a fixed displacement. High quality pumps sometimes have an adjustable displacement.

#### **Displacement**

Displacement is the amount of liquid transferred from a pump's inlet to its outlet in one revolution or cycle. In a rotary pump, displacement is expressed in cubic inches per revolution and in a reciprocating pump in cubic inches per cycle. If a pump has more than one pumping chamber, its displacement is equal to the displacement of one chamber multiplied by the number of chambers. Displacement is either fixed or variable.

#### **Fixed-Displacement Pump**

In this pump, the GPM output can be changed only by varying the drive speed. The pump can be used in an open-center system-a pump's output has a free-flow path back to a reservoir in the neutral condition of a circuit.

#### **Variable-Displacement Pump**

In this pump, pumping-chamber sizes can be changed. The GPM delivery can be changed by moving the displacement control, changing the drive speed, or doing both. The pump can be used in a closed-center system-a pump continues to operate against a load in the neutral condition.

#### **Operation**

The hydraulic pump creates the flow of fluid within the hydraulic system. The pressure in a hydraulic system is caused by a restriction placed in the path of the fluid as it leaves the pump. Because of the resulting mechanical drive and positive displacement, the pump merely moves the fluid regardless of the restriction. When enough pressure is built up, movement of the restriction occurs or a relief valve placed in the system opens, allowing the fluid to return to the reservoir or the suction side of the pump. When the pump operates, hydraulic fluid is trapped between the gear teeth and the pump housing and is carried to the outlet side of the pump. As the teeth mesh,

a seal is freed by the mating surfaces that prevent the oil from leaking back to the inlet side of the pump. The sealing action causes the oil to be forced out of the pump and into the system.

**Positive-Displacement Pumps**

With this pump, a definite volume of liquid is delivered for each cycle of pump operation, regardless of resistance, as long as the capacity of the power unit driving a pump is not exceeded. If an outlet is completely closed, either the unit driving a pump will stall or something will break. Therefore, a positive-displacement-type pump requires a pressure regulator or pressure-relief valve in the system. Next figure shows a reciprocating-type, positive-displacement pump.

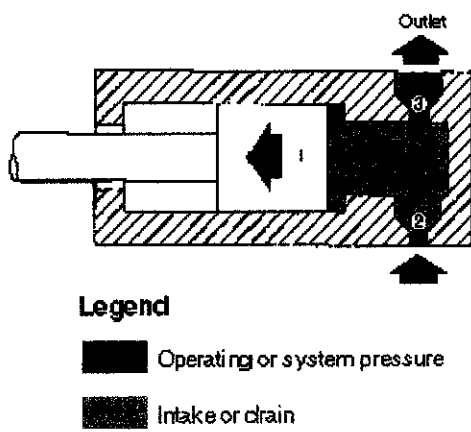

Figure 7: Reciprocating type pump

Figure below shows another positive-displacement pump. This pump not only creates flow, but it also backs it up. A sealed case around the gear traps the fluid and holds it while it moves. As the fluid flows out of the other side, it is sealed against backup. This sealing is the positive part of displacement. Without it, the fluid could never overcome the resistance of the other parts in a system.

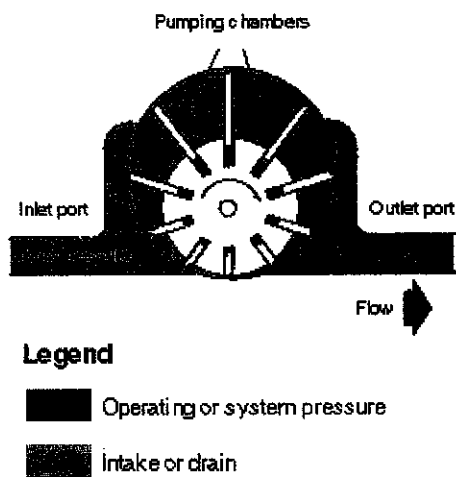
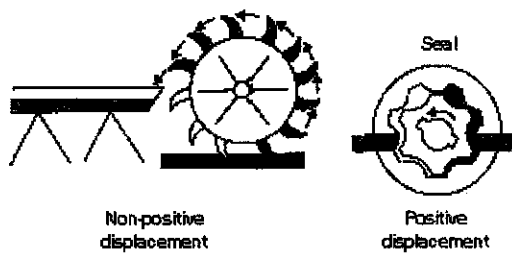

Figure 8: Positive displacement pump

## Non-positive Displacement Pumps

With this pump, the volume of liquid delivered for each cycle depends on the resistance offered to flow. A pump produces a force on the liquid that is constant for each particular speed of the pump. Resistance in a discharge line produces a force in the opposite direction. When these forces are equal, a liquid is in a state of equilibrium and does not flow. If the outlet of a non-positive displacement pump is completely closed, the discharge pressure will rise to the maximum for a pump operating at a maximum speed. A pump will churn a liquid and produce heat. Figure below shows a non-positive displacement pump. A water wheel picks up the fluid and moves it.



### Legend

□ Operating or system pressure

■ Exhaust flow

Figure 9: Non-Positive displacement pump

### Characteristics:

Non-positive Displacement Pump	Positive Displacement Pump
Have a pulse with each stroke or each time a pumping chamber opens to an outlet port	Provide a smooth, continuous flow
Pressure can reduce a non-positive pump's delivery. High outlet pressure can stop any output; the liquid simply re-circulates inside the pump	Pressure affects the output only to the extent that it increases internal leakage.
With the inlets and outlets connected hydraulically, cannot create a vacuum sufficient for self-priming; they must be started with the inlet line full of liquid and free of air	Often are self-priming when started properly.

## **Gear pumps**

Gear pumps are simple and economic pumps that are used in simple hydraulic systems. The efficiency is not very good, especially at higher pressures the efficiency goes down rapidly. Although the design pressure for gear pumps might be given as 275 bars, they should not be used over about 180 bars, whereas the normal working pressure should be below 120 bars. The swept volume of gear pumps for hydraulics will be between about 1 cm<sup>3</sup> (0.001 litre) and 200 cm<sup>3</sup> (0.2 litre).

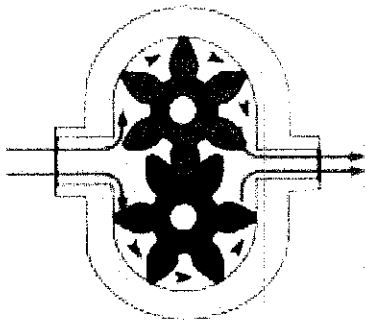

**Gear pump with external teeth**

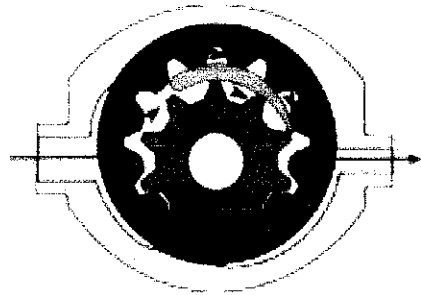

**Gearpump with internal teeth**

**Figure 10: Gear Pumps**

## 2.4 Hydraulic Circuit for Cranes

In order to perform various movements such as raising and lowering the boom, winding in the wire rope, swinging and extending or retracting the boom, a hydraulic crane uses a hydraulic circuit that is made up of the following devices: a hydraulic pump to generate force for motion, hydraulic cylinders and motors as drive devices, and various valves as control devices.

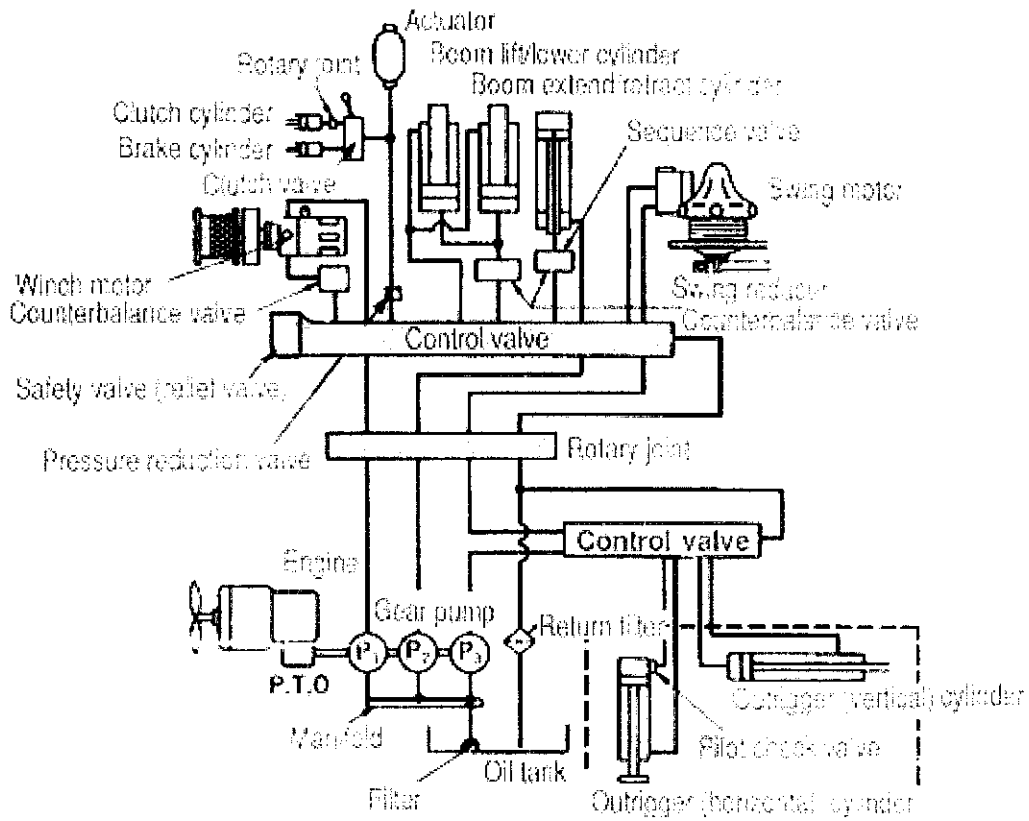

Figure 11: Basic Hydraulic Circuit in Mobile Crane



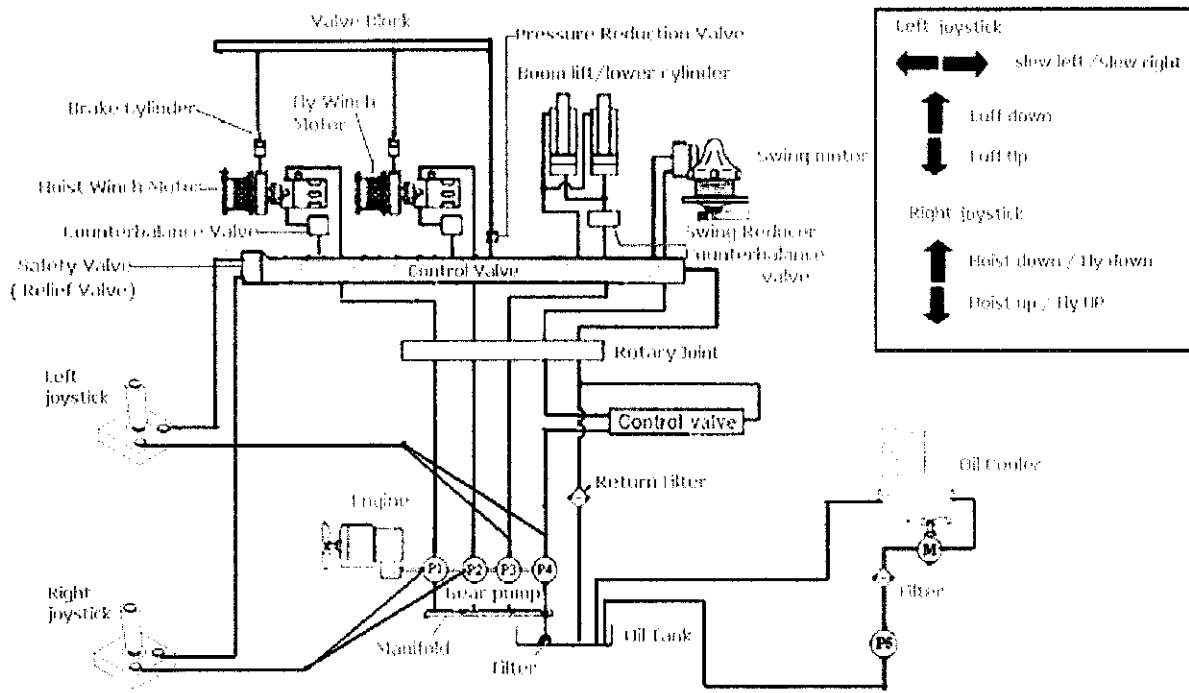

Figure 12: Hydraulic circuit for Ram Luffing Crane

### 3.0 METHODOLOGY

First of all the project is basically divided by two different sections of timeline, they are FYP I and II respectively. During FYP I, the preliminary research and literature review are the most important part for understanding the project thoroughly while finding the solution for the problem. The objectives and the expected outcomes are also need to take into account so that the project will flow finely by stages and procedures following the timeline. The works like scheduling lab came right after that followed by calculation of data and analysis. Thus, they will end with comparison of data obtained. Meanwhile for FYP II, the experiments takes place including the planned site visit to Favelle Favco which is a big company specializing in crane, in Seremban. There, further improvement is to be expected for the project. Last but not least, the project will be concluded and finalized by final report. Figure 10 is the flowchart of expected activities while figure 11(a) and (b) is the Gantt chart for project timeline.

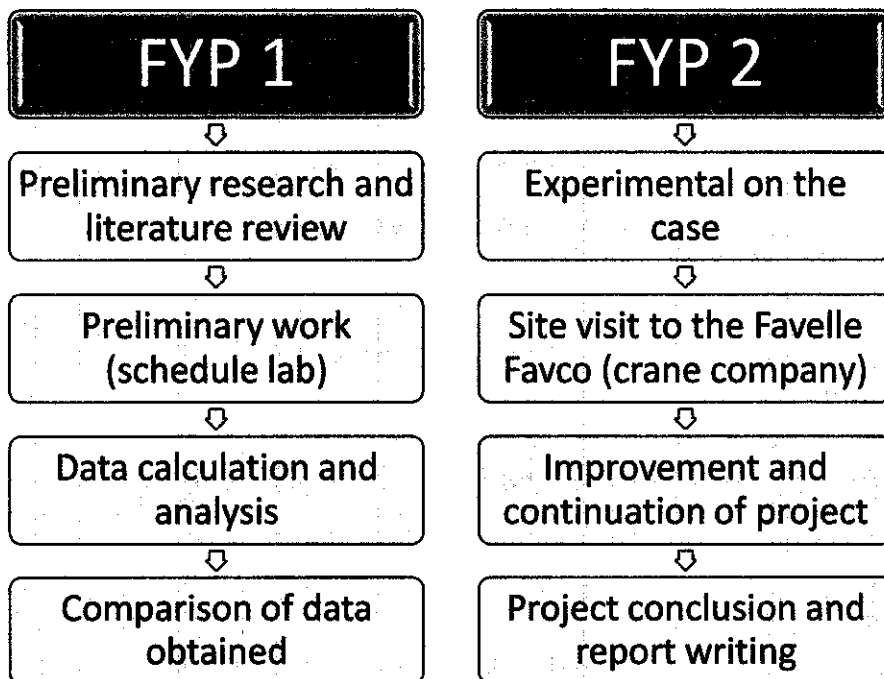

Figure 13: Project Flowchart

Week	1	2	3	4	5	6	7	8	9	10	11	12	13	14
<b>Detail</b>														
Problem definition and theory	■	■	■	■	■	■	■							
Research on crane energy recovery methods (Objective 1)					■	■	■	■						
Experimentation and data analysis for the effectiveness of each method.								■	■	■	■	■		
Research, calculate and measures the effect of energy recovery. (Objective 2)									■	■	■	■		
For each equipment, find out the effect of energy recovery.									■	■	■	■	■	
Research on heat loading procedure and the results. (Objective 3)											■	■	■	■
Experimentation on heat loading and the effect of countering the back driving phenomenon.											■	■	■	■
Conclude the project and find out the correlation between all the 3 objectives.													■	■

Figure 14: Gantt chart of the project

Key Milestones	FYP1				FYP2			
	MAY	JUN	JUL	AUG	SEP	OCT	NOV	DEC
Problem definition and theory								
Research on crane energy recovery methods (Objective 1)								
Experimentation and data analysis for the effectiveness of each method.								
Research, calculate and measures the effect of energy recovery. (Objective 2)								
For each equipment, find out the effect of energy recovery.								
Research on heat loading procedure and the results. (Objective 3)								
Experimentation on heat loading and the effect of countering the back driving phenomenon.								
Conclude the project and find out the correlation between all the 3 objectives.								

Figure 15: Key Milestone

## 4.0 RESULT AND DISCUSSION

### 4.1 Energy Recovery System for Hydraulic Crane

An assistant system with an accumulator is used to drive one joint of an example crane together with an electro hydraulic load-sensing (ELS) system. The practical system is tested. The hydrostatic analysis of energy transfer is based on the experimental process and an assumed typical duty cycle. The experimental and theoretical results show that the application of the assistant system with the ELS crane system can recover and reutilize energy, save pump supply energy and improve energy utilization of the crane system. [3]

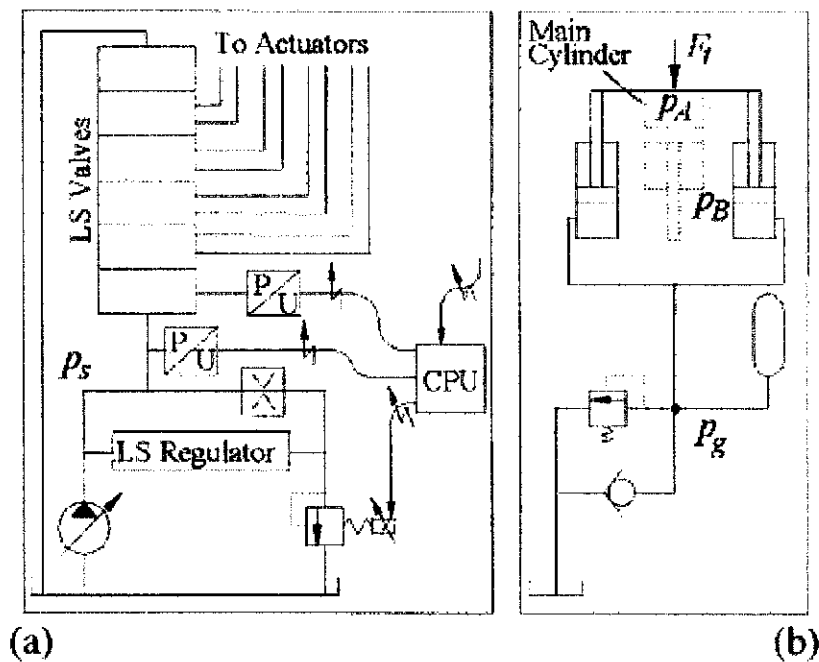

Figure 16: Main system and assistant system [3]

### Mechanism of Energy Recovery

Figure 3 shows the basic mechanism for energy recovery and reutilization in a hydraulic crane. It includes a main system and an assistant hydraulic circuit as in Figure 16(a) and (b). The assistant system consists of two assistant cylinders, an accumulator, etc. The main system is an electro hydraulic load-sensing (ELS) system with a variable displacement pump. [3]

The work mechanism is as follows:

- During the 1<sup>st</sup> outstroke movement, the two assistant cylinders are driven by the main cylinder and oil from the reservoir is drawn into their chambers through the check valve.
- During the following in stroke movement, the oil from the chambers is charged into the accumulator.
- With the 2<sup>nd</sup> outstroke movement, the pump will supply enough hydraulic energy to drive the main cylinder, and the accumulator will release its storage energy to drive the assistant cylinders. Both the main cylinder and the assistant cylinders share the load force together. [3]

### Experiment in an Example Crane

The above energy storage theory is used for the drive of joint 1 in the example hydraulic crane in Figure 4. The main cylinder is cylinder 1.

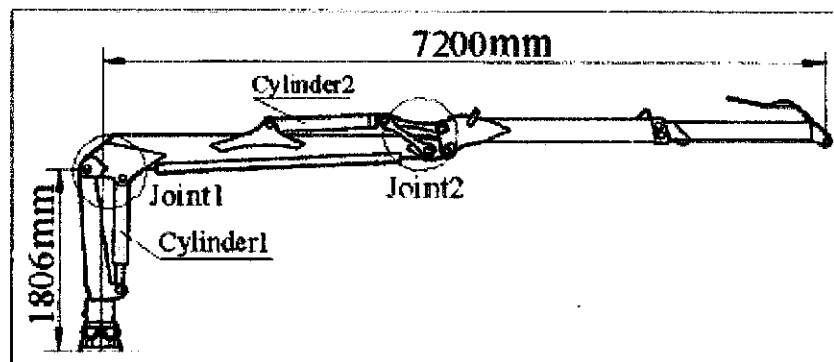

Figure 17: example of hydraulic crane [3]

### Example crane

The example crane in Figure 17 is a Log lift loader. It has four main DOFs: rotating, lifting, transferring and telescope. The crane system is a stable ELS system based on a microcontroller (Motorola 68HC11, 8-bit). Its overall configuration is described in Figure 16(a). Four hydraulic functions share one pump. The choice of the ELS system in the test is to achieve good behavior and stable and fast response. More often, the dynamics and controllability of traditional LS systems are not satisfactory. [3]

## Experimental environment

The measurement environment consists of the following:

- The main system, an ELS crane system, shown in Fig. 3(a), is used to drive joint 1. During the practical measurement, other joints have no movement. Cylinder 2 and the telescope are fully retracted.
- The assistant system is a double-cylinder system with one bladder accumulator, a relief valve, a check valve, anti-air valves, etc. The double-cylinder structure is based mainly on the considerations of simple installation and connection.
- The charged pressure  $p_{g0}$  is, in the two cases, 0 or 7.5MPa. There is no leakage through the relief valve.
- The step signal is added to the LS valve to realize upward and downward movement.
- The control is operated manually.

## Results

When  $p_{g0} = 0$ , the assistant system has no obvious effect on the operation of joint 1 except for additional friction forces. Therefore, it is reasonable to regard the system at  $p_{g0} = 0$  as the original crane system. Compared with the original main system, it is obvious that pump pressure  $p_s$  is greatly reduced during the upward movement. The pressure,  $p_A$ , in the main cylinder is much lower owing to the energy recovery and release in the assistant system. Moreover, the dynamic performances are as good as the original one. Therefore, it is reasonable and feasible for the drive concept to store energy and improve energy utilization efficiency in the hydraulic crane. [3]

## Energy Evaluation

Work path	Crane system without assistant system		Crane system with assistant system			
	$E_{\text{pump}}$ (kJ)	$E_{\text{loss}}$ (kJ)	$E_{\text{pump}}$ (kJ)	$E_{\text{loss}}$ (kJ)	$E_{\text{acc}}$ (kJ) recovered	$E_{\text{acc}}$ (kJ) regenerated
C→B	21.278	11.621	21.278	11.621	—	—
B→A	18.472	27.508	18.472	18.811	8.697	—
A→B	65.063	46.377	50.038	39.917	—	8.564
B→C	5.456	29.673	5.456	21.446	8.227	—

**Table 1: Energy Transfer Results**

1. From C to B. This is a preset step so that cylinder 1 has outstroke movement and the assistant cylinders can be filled with hydraulic oil.
2. From B to A. The accumulator stores and recovers energy. The pump pressure depends on the load force of cylinder 2. Thus, the pump supply energy  $E_{\text{pump}}$  has no change and the recovered energy  $E_{\text{acc}}$  is mainly from  $E_{\text{loss}}$ . The direct source is the work done by mass loads of mechanical links and the lifted object, or rather it is potential energy. In Table 2 it is not difficult to find their energy equilibrium relation.
3. From A to B. The accumulator releases its stored energy and the assistant cylinders share the load force of joint 1 with the main cylinder. The pump pressure depends on the load force of cylinder 1. Therefore  $E_{\text{pump}}$  is reduced.
4. From B to C. This is similar to the path from B to A.
5. For the following cycle the accumulator releases energy along the path from C to B.

### Accumulator

The accumulator plays a very important role in the assistant system. Its selection should consider economics, weight saving, installation and controllability. A bladder accumulator has been used in the experiment. The charge pressure set is the key factor that has a direct effect on the energy recovery and reutilization. Its reasonable set can obtain the necessary results. In addition, the proportional control accumulator is the advantageous choice for further research owing to its controllability.



## Conclusions

The following conclusions can be drawn from the experimental and theoretical analysis:

- The application of an assistant system for energy recovery and utilization with the ELS crane system is reasonable and feasible. It can recover and reutilize energy.
- It can cause a considerable additional reduction in pump supply energy and work losses in the system for the same work situation. Therefore, the energy utilization in the hydraulic crane can be greatly improved.
- The energy losses in a hydraulic crane are from two sources: hydraulic energy and potential energy of mass loads of mechanical links and the lifted object.
- The successful experiment in a hydraulic crane will encourage its extension to commercial applications in other lifting machinery.
- The selection and parameter set of the accumulator is an important factor in the assistant system. Further work should seek adaptation to a wide range of practical applications and improve energy efficiency as much as possible.
- Compared with the energy-saving result, the cost, weight, installation and controllability of the energy recovery system require careful consideration for the first investment. [3]

From Energy Evaluation, energy recovery by using accumulator is;

$$\text{Energy Recovery} = \frac{\text{Energy Recovered}}{\text{Energy Loss}} \times 100\%$$

$$B - A = \frac{8.697}{18.811} \times 100\% = 46.2\%$$

$$B - C = \frac{8.227}{21.446} \times 100\% = 38.4\%$$

$$\text{Average Energy Recovery} = \frac{46.2 + 38.4}{2}$$

$$\text{Average Energy Recovery} = 42.3\%$$

## 4.2 Heat Loading

Heat loading objective or its main purposes is to maintain a power resistance at the hydraulic motor at the winch that having the back driving phenomenon. By doing this, there will be a countering effect of energy equivalent to the lowering power generated.

The principle of heat loading is to put an additional pump to absorb the excess power from prime mover during the phenomenon of back driving. The consequence of this method is the system will generate additional heat. Thus, another system is needed to cool it down. The un-necessary additional system to cool the system down is the reason why this method is not too effective when applied.

## 4.3 Calculation

### Calculating power of engine (electric motor)

$$Power = V \times I \times 1.732 \times PF$$

Where;

V = Voltage

I = Current

1.732 = Root mean square

PF = Power Factor

From the catalog of crane electric motor model 250M2-8 from YZ Crane Motor Company, given label of V is 400V, I is 100A, 50Hz AC, 3-phase, and Power Factor is 0.81, we can calculate the Power of the engine by using the above equation.

$$Power = 400V \times 100A \times 1.732 \times 0.81$$

$$Power = 56.12kW$$

## Calculating required Gear Pump Power



Figure 18: Gear pump

1) First of all, we select one pump model from the available catalogue.

	B-9000
Typical service	General Chemical
Materials	400 Series Stainless Steel
Outlet pressure	Up to 1000 psi (70 Bar)
Inlet pressure	Up to 300 psi (20 Bar)
Temperature	Up to 645° F (340° C) *
Viscosity	1 cP or Greater
Flow Rate	Up to 27,000 cc/min
Lubricity	Good / Excellent
Fluid compatibility	Mildly corrosive

2) Then, select maximum operating speed

Operating Conditions			Suggested Maximum Speed (RPM)		
Lubricity	and	Viscosity	B-9000	C-9000	H-9000
Excellent (Oils, etc.)		< 1,000 cP	500	1000	500
Good (Polyols, etc.) to Excellent		1,000 < 10,000 cP	300	500	300
Poor (Solvents, etc.) to Excellent		> 10,000 cP	150	150	150
Abrasive (TiO <sub>2</sub> , etc. - Consult Factory)		> 1 cP	-	-	75

Take 500RPM

### 3) Select Pump Size

Maximum flow (cc/min) ÷ maximum operating speed = pump capacity (cc/rev)

$$\text{Pump capacity} \left( \frac{\text{cc}}{\text{rev}} \right) = \text{Maximum flow (cc/min)} \div \text{maximum operating speed}$$

$$\text{Pump capacity} \left( \frac{\text{cc}}{\text{rev}} \right) = 31\,822.63 \text{ (cc/min)} \div 500\text{rpm}$$

$$\text{Pump capacity} \left( \frac{\text{cc}}{\text{rev}} \right) = 63.65 \left( \frac{\text{cc}}{\text{rev}} \right)$$

The pump capacity then can be round up to the next largest pump. From the list below, the available sizes is **90cc/rev**.

Capacities (cc/rev): 0.05, 0.3, 0.6, 1.2, 2.4, 4.5, 9.0, 15, 30, 45, and 90.

Calculate minimum operating speed (RPM)

$$= \text{minimum flow (cc/min)} \div \text{pump capacity (cc/rev)}$$

$$\text{Minimum operating speed (RPM)} = 27,000 \text{ (cc/min)} \div 63.65 \text{ (cc/rev)}$$

$$\text{Minimum operating speed (RPM)} = 424.19\text{rpm}$$

### 4) Select Reducer Ratio

Pump Speed Range with 1800 RPM Motor, 20:1 Turndown							
Speed Range (n - N)	90 - 1800	29 - 576	13 - 249	18 - 343	8 - 155	7 - 123	5 - 87
Reducer Ratio	1:1 (Direct)	3.12 : 1	7.23:1	5.24 : 1	11.55 : 1	14.57 : 1	20.62 : 1

Thus from the table, reducer ration is 3.12:1 and maximum rpm is 576 rpm.

5) Calculate Maximum pump torque

Capacity (cc/rev)	$K_1 / K_2$	$K_3 / K_4$	Max Torque* (in-lbs/NM)
0.05	0.0005 / 0.85	0.0008 / 0.096	10 / 1.1
0.3	0.003 / 2.11	0.004 / 0.24	90 / 10
0.6	0.006 / 2.34	0.010 / 0.26	200 / 23
1.2	0.012 / 2.82	0.018 / 0.32	200 / 23
2.4	0.023 / 3.78	0.037 / 0.43	200 / 23
4.5	0.044 / 6.85	0.070 / 0.77	400 / 45
9	0.087 / 8.56	0.141 / 0.97	400 / 45
15	0.146 / 14.66	0.233 / 1.66	600 / 68
30	0.291 / 18.57	0.468 / 2.10	600 / 68
45	0.437 / 32.78	0.701 / 3.70	1950 / 220
90	0.873 / 30.61	1.404 / 3.46	1950 / 220
* Add 20% to Max. Torque limit for 400 Series SS			

Pump torque:

$$T (in - lbs) = (K1 \cdot \Delta P (psi)) + (K2 \cdot N \cdot \mu / 100,000)$$

Or

$$T (Nm) = (K3 \cdot \Delta P (kg/cm^2)) + (K4 \cdot N \cdot \mu / 100,000)$$

$K1, K2, K3, K4$  = constants from adjacent chart

$\Delta P$  = Differential Pressure (outlet pressure - inlet pressure)

$N$  = Maximum pump speed, based on reducer ratio.

$\mu$  = Viscosity (cps).

$$T (in - lbs) = (0.873 \cdot (1000 - 300) psi) + (30.61 \cdot 576rpm \cdot 1 / 100,000)$$

$$T (in - lbs) = 611.28 (in - lbs)$$

$$T (Nm) = (1.404 \cdot (70.3 - 21.09) kg/cm^2) + (3.46 \cdot 576rpm \cdot 1 / 100,000)$$

$$T (Nm) = 69.11Nm$$

Compare the calculated torque to the maximum torque shown in the adjacent chart. The calculated torque must not exceed the maximum torque.

## 6) Calculate Power

$$HP = T / (35 \times 0.85 \times R)$$

Where;

T = Maximum torque (in lbs) from step 5

R = Reducer ratio from step 4 (for example, if 7.23:1 use 7.23)

$$HP = 611.28 / (35 \times 0.85 \times 3.12)$$
$$HP = 6.59HP$$

Or

$$KW = T / (5.3 \times 0.85 \times R)$$

Where;

T = Maximum torque (Nm) from step 5

R = Reducer ratio from step 4 (for example, if 7.23:1 use 7.23)

$$KW = 69.11 / (5.3 \times 0.85 \times 3.12)$$
$$KW = 4.92kW$$

### Calculating the requisite power of the hoisting motor

For calculating requisite motor power the following items must be considered:

- The resistance due to normal (nominal) hoisting
- The resistance due to acceleration of the rotating masses
- The resistance due to acceleration of the linear moving masses
- For the hoisting, the influence of the angles  $\alpha$  have to be taken into account, as the forces and the motor power are multiplied in this wire rope system

With  $f = 1 / \cos \alpha$

With  $\alpha$  is then half of the biggest angle between the wire ropes when the load is in the highest position.

### Main Characteristic Example:

Weight of load: spreader and container or grab and contents or hook and load.

$$Q (kg) = 66\,000\,kg$$
$$Q (kN) = 660\,kN$$

Maximum speed of the load:

$$v \left( \frac{m}{min} \right) = 60 \left( \frac{m}{min} \right)$$
$$v \left( \frac{m}{sec} \right) = 1 \left( \frac{m}{sec} \right)$$

Efficiency of all gearings and rope sheaves:

$$\eta_t = 0.90$$

Motor speed (rev/min):

$$n = 783 \left( \frac{rev}{min} \right)$$

Inertia moment on motor shaft from motor(s); break sheave(s); and gearbox:

$$J_{rot} = J_m + J_b + jgb (kgm^2) = 24 + 16 + 6$$

$$J_{rot} = 46\,kgm^2$$

Acceleration time (sec):

$$t_a = 2sec$$

Acceleration of the mass Q:

$$a = \frac{v}{t} \left( \frac{m}{sec^2} \right) = \frac{1}{2} = 0.5 \frac{m}{sec^2}$$

## Power Calculation (Torque, Nm and kilo Watts, kW)

### 1. Resistance due to nominal hoisting (full load at maximum speed):

$$N1 = \frac{Q \times v}{\eta} \text{ (kW)} = \frac{660 \times 1}{0.9}$$
$$N1 = 773 \text{ kW}$$

$$M1 = \frac{N1 \times 9550}{n} \text{ (Nm)} = \frac{773 \times 9550}{783}$$
$$M1 = 8940 \text{ Nm}$$

### 2. Resistance due to accelerating the rotating masses:

$$\omega = \frac{n \times 2 \times \pi \text{ (rad)}}{60 \text{ (sec)}} = \frac{783 \times 2 \times \pi}{60}$$
$$\omega = 81.95 \text{ rad/sec}$$

$$M2 = \frac{J_{rot} \times \omega}{ta} \text{ (Nm)} = \frac{46 \times 81.95}{2}$$

$$M2 = 1885 \text{ Nm}$$

$$N2 = \frac{n \times M2}{9550} \text{ (kW)} = \frac{783 \times 1885}{9550}$$

$$N2 = 154.5 \text{ kW}$$

### 3. Resistance due to accelerating the linear masses:

$$F3 = \frac{Q \times v}{g \times ta} \text{ (kN)} = \frac{660 \times 1}{9.81 \times 2}$$
$$F3 = 33.6 \text{ kN}$$

$$N3 = \frac{F3 \times v}{\eta} \text{ (kW)} = \frac{33.6 \times 1}{0.9}$$

$$N3 = 37.33 \text{ kW}$$

$$M3 = \frac{N3 \times 9550}{n} \text{ (Nm)} = \frac{37.33 \times 9550}{783}$$

$$M3 = 455 \text{ Nm}$$



## Conclusion;

Addition:	Torque (Nm)	kiloWatts (kW)
1. Nominal hoisting	M1 = 8940 Nm	N1 = 733 kW
2. Acceleration of the rotating masses	M2 = 1885 Nm	N2 = 154.5 kW
3. Acceleration of the linear moving masses	M3 = 455 Nm	N3 = 37.33 kW
Total:	$\Sigma M = 11\ 280\ \text{Nm}$	$\Sigma N = 924.83\ \text{kW}$

## 4.4 Discussion

By calculating power of engine, gear pump and hoisting motor, we can estimate the energy recovery percentage of using the accumulator from the previous experiment. The percentage average of recovery is 42.3%. Thus;

$$1\text{kW} = 1\text{kJ/s}$$

$$\text{Recovery Energy} = \text{Energy(kJ)} \times 0.423$$

### Estimated energy recovery of engine (electric motor)

$$\text{Recovery Energy} = 56.12\text{kJ} \times 0.423$$

$$\text{Recovery Energy} = 23.7\text{kJ}$$

### Estimated energy recovery of Gear Pump Power

$$\text{Recovery Energy} = 4.92\text{kJ} \times 0.423$$

$$\text{Recovery Energy} = 2.08\text{kJ}$$

### Estimated energy recovery of the hoisting motor

$$\text{Recovery Energy} = 924.83\text{kJ} \times 0.423$$

$$\text{Recovery Energy} = 391.2\text{kJ}$$

## **5.0 CONCLUSION**

1. Energy recovery method using accumulator as an assistant system is proven to be an efficient way to conserve energy.
2. Using the heat loading method to counter the back driving problem is proven to be not efficient because of the requirement to cool the system back after that.
3. Various formulas and calculations are needed in order to find the requisite power of each equipment.
4. Using the power obtained, the estimated energy recovery can be calculated using the data from previous experiment of energy recovery.

## **6.0 RECOMMENDATION**

Energy recovery method using accumulator as an assistant system is proven to be an efficient way to conserve energy. It can cause a considerable additional reduction in pump supply energy and work losses in the system for the same work situation. Therefore, the energy utilization in the hydraulic crane can be greatly improved. This successful experiment in a hydraulic crane will encourage its extension to commercial applications in other lifting machinery. Further work should seek adaptation to a wide range of practical applications and improve energy efficiency as much as possible.

## REFERENCE

- 1) By Cynthia Olga. Article Source: EzineArticles.com. <http://www.gantry-crane.org/2011/01/27/hoisting-crane-6/>
- 2) By Michelle Russell. Article Source: EzineArticles.com. <http://www.gantry-crane.org/2011/01/25/hoisting-crane-5/>
- 3) An energy recovery system for a hydraulic crane. X Liang and T Virvalo. *Proceedings of the Institution of Mechanical Engineers, Part C: Journal of Mechanical Engineering Science* 2001 215: 737 DOI: 10.1243/0954406011523983
- 4) 3rd Australasian Engineering Heritage Conference 2009. Remnants of Early Hydraulic Power Systems. J W Gibson MA (Syd), MIE Aust. & M C Pierce BE (Elec), FIE Aust.
- 5) *Fast rescue craft recovery by installation crane. Phase 2 studies. Prepared by MB Mechanical Handling Consultants for the Health and Safety Executive* 2006
- 6) <http://www.elec-toolbox.com/Formulas/Motor/mtrform.htm>
- 7) <https://www.ranchowater.com/files/engineering/08Tech%20Provision%20Div%205.pdf>
- 8) Crane & Derrick, 3<sup>rd</sup> Edition, Howard I. Shapiro, Jay P. Shapiro, Lawrence K. Shapiro, McGraw-Hill Professional Engineering.
- 9) Cranes Design, Practice, and Maintenance, 2<sup>nd</sup> Edition, by Ing. J. Verschoof, Professional Engineering Publishing Limited London and Bury St Edmunds, UK.