

METHOD OF LOCATING FAILURE OF STREET LIGHTING

By

EMI ZURIMA BT ISMAIL

Final Report

Submitted to the Electrical & Electronics Engineering Programme
in Partial Fulfillment of the Requirements
for the Degree
Bachelor of Engineering (Hons)
(Electrical & Electronics Engineering)

Universiti Teknologi Petronas

Bandar Seri Iskandar

31750 Tronoh

Perak Darul Ridzuan

© Copyright 2011

by

EMI ZURIMA BT ISMAIL, 2011

CERTIFICATION OF APPROVAL

METHOD OF LOCATING FAILURE STREET LIGHTING

by

Emi Zurima Bt Ismail

A project dissertation submitted to the
Electrical & Electronics Engineering Programme
Universiti Teknologi PETRONAS
in partial fulfillment of the requirement for the
Bachelor of Engineering (Hons)
(Electrical & Electronics Engineering)

Approved:

Ir. Mohd Faris bin Abdullah
Project Supervisor

UNIVERSITI TEKNOLOGI PETRONAS
TRONOH, PERAK

May 2011

CERTIFICATION OF ORIGINALITY

This is to certify that I am responsible for the work submitted in this project, that the original work is my own except as specified in the references and acknowledgements, and that the original work contained herein have not been undertaken or done by unspecified sources or persons.

Emi Zurima Bt Ismail

ACKNOWLEDGEMENTS

First of all, thanks to Allah S.W.T for the blessing and guidance for me to complete my final year project. Special appreciation goes to my supervisor, Ir Mohd Faris Bin Abdullah for his supervision and constant support. His invaluable help of constructive comments and suggestion throughout the experimental and thesis works have contributed to the success of this research.

Special thanks also to all my friends especially my roommate, Fahim for her kindness and moral support during completing this project. Thanks for the friendship and memories. Not to forget, a million thanks to lab technician who willing to guide me whenever I face a problem when doing the experiment.

Last but not least, my deepest gratitude goes to my beloved parents Mr. Ismail Bin Idris and Mrs. Masturah Bt Lope Ahmad and also to my siblings for their endless love, prayers and encouragement. To those who indirectly contributed in this research, your kindness means a lot to me. Thank you very much.

ABSTRACT

Street lighting is a part of the distribution system. These facilities were owned, installed, operated and maintained by the utility supplying electricity which is Tenaga Nasional Berhad (TNB) or local municipal. This purpose of this report is to discuss about the project and the method of locating failure street lighting lantern by using measurement at the control panel. The report starts with the objective and scope of study. The possibilities of this project have been discussed and the problem statements that lead to the idea of the project have been identified. The system of street lighting and the theory on how the system functioned also included. The method of locating failure street lighting has been discussed in the literature view. In methodology part, the planning of this project has been shown and the Gantt chart has been drawn. Then, the result and discussion were discussed in chapter 4. Finally, chapter 5 explains about the conclusion and recommendation of this project.

TABLE OF CONTENTS

CERTIFICATION OF APPROVAL	ii
CERTIFICATION OF ORIGINALITY	iii
ACKNOWLEDGEMENT	iv
ABSTRACT	v
LIST OF FIGURES	viii
LIST OF TABLE	x

CHAPTER 1: INTRODUCTION

1.1	Background of Study.....	1
1.2	Problem Statement.....	2
1.3	Objective.....	2
1.4	Scope of Study.....	3
1.5	Reliability and Feasibility of the project.....	3

CHAPTER 2: LITERATURE REVIEW

2.1	The Street Lighting System.....	4
	2.1.1 Function of street lighting component.....	4
2.2	Current Level Detection Method to Locate Faulty of Street Lighting	6
2.3	Method of Locating Faulty Street Lighting using Wireless Sensor Network (WSN).....	7
2.4	Distance Relay Protection.....	8

CHAPTER 3: METHODOLOGY

3.1	Impedance Base Algorithm.....	10
3.2	Manual Calculation for impedance.....	11
3.3	PSCAD Simulation for Impedance.....	12
3.4	Prototype of Street Lighting Conductors.....	13

3.4.1	Fixed Voltage Source with Variable Resistor.....	14
3.4.2	Fixed Voltage Source with Fixed Resistor.....	14
3.4.3	Variable Voltage Source with Fixed Resistor.....	16
3.4.4	Two-core wire.....	17
CHAPTER 4:	RESULT AND DISCUSSION	
4.1	Manual Calculation for Impedance.....	18
4.2	PSCAD Simulation for Impedance.....	19
4.3	Fixed Voltage Source with Variable Resistor.....	21
4.4	Fixed Voltage Source with Fixed Resistor.....	24
4.5	Variable Voltage Source with Fixed Resistor.....	28
4.6	Two-core Wire.....	32
CHAPTER 5:	CONCLUSION AND RECOMMENDATION	
5.1	Conclusion.....	38
5.2	Recommendation.....	39
REFERENCES.....		40
APPENDICES.....		41

LIST OF FIGURES

Figure 1	Street lighting wiring circuit	4
Figure 2	Circuit constructed for lighted and unlighted part	6
Figure 3	Distance Protection Relay	8
Figure 4	Flow Chart for Methodology	9
Figure 5	Circuit diagram for Impedance Base Method	10
Figure 6	Circuit diagram for manual calculation	11
Figure 7	Example of PSCAD view	12
Figure 8	Street Lighting Conductor Prototype	13
Figure 9	Prototype with decade resistance block	14
Figure 10	Prototype using breadboard	14
Figure 11	Prototype with using connector	15
Figure 12	Variable auto transformer	16
Figure 13	Prototype using multi-coil wire	17
Figure 14	Graph for current versus number of lights	18
Figure 15	Graph for total impedance versus number of lights	18
Figure 16	Circuit diagram using PSCAD	19
Figure 17	Graph for voltage versus number of lights	20
Figure 18	Graph for current versus number of lights	20
Figure 19	Graph for total impedance versus number of lights	20
Figure 20	Current graph for 1 Ω , 2 Ω , 3 Ω , 4 Ω , and 5 Ω	23
Figure 21	Impedance graph for 1 Ω , 2 Ω , 3 Ω , 4 Ω , and 5 Ω	23
Figure 22	Current graph using multimeter	24
Figure 23	Impedance graph using multimeter	25
Figure 24	Current graph using DAQ	26
Figure 25	Impedance graph using DAQ	27
Figure 26	Current graph using fixed resistor	31
Figure 27	Impedance graph using fixed resistor	31

Figure 28	Current graph using two-core wire	35
Figure 29	Impedance graph using two-core wire	35
Figure 30	Graph for Impedance Ratio Factor (IRF	37

LIST OF TABLES

Table 1	Description for six cases	13
Table 2	Percentage of voltage applied	16
Table 3	Result for R=1 Ω	21
Table 4	Result for R= 2 Ω	21
Table 5	Result for R= 3 Ω	22
Table 6	Result for R= 4 Ω	22
Table 7	Result for R= 5 Ω	22
Table 8	Result for six cases using multimeter	24
Table 9	Result for six cases using DAQ	26
Table 10	Result for six cases using 207 V	28
Table 11	Result for six cases using 210 V	28
Table 12	Result for six cases using 215 V	28
Table 13	Result for six cases using 220 V	29
Table 14	Result for six cases using 228 V	29
Table 15	Result for six cases using 232 V	29
Table 16	Result for six cases using 235 V	30
Table 17	Result for six cases using 237 V	30
Table 18	Result for six cases using 240 V	30
Table 19	Result for six cases using 241.5 V	31
Table 20	Result for six cases using 207 V	32
Table 21	Result for six cases using 210 V	33
Table 22	Result for six cases using 215 V	33
Table 23	Result for six cases using 220 V	33
Table 24	Result for six cases using 228 V	33
Table 25	Result for six cases using 232 V	34
Table 26	Result for six cases using 235 V	34
Table 27	Result for six cases using 237 V	34

Table 28	Result for six cases using 240 V	34
Table 29	Result for six cases using 241.5 V	35
Table 30	Impedance Ratio Factor (IRF)	36

CHAPTER 1

INTRODUCTION

1.1 Background of Study

Street light is a raised source of light on the edge on the road where it can be turned on at a certain time every night [1]. The earliest lamps were used by Greek and Roman civilizations, where light primarily served the purpose of security, both to protect the wandered from tripping over something on the path as well as keeping the potential robbers at bay. The first electric street lighting employed arc lamps, ‘Electric candle’, ‘Jablochkoff candle’ or ‘Yablochkov candle’ developed by the Russian Pavel Yablochkov in 1875. This was a carbon arc lamp employing alternating current, which ensured that both electrodes were consumed at equal rates [1]. Now, street lighting commonly uses high-intensity discharge lamps, often HPS (high pressure sodium lamps).

The monochromatic deep yellow wavelength light produced by the sodium vapor lamp is the ‘photopic’ range in which humans see best. Hence the vision even in foggy and dusty conditions is excellent in this light [2]. All street light can be controlled by control panel but it cannot locate and detect which street light is not functioning. So, this project is to introduce the impedance base method to locate the unlighted street light. Measurement of voltage and current is needed in order to get the impedance value. Last but not least, an algorithm can be emerging by using impedance base value.

1.2 Problem statement

Nowadays, the method that TNB or local municipal use to monitor whether all street lights lightening up is by manpower patrolling at all streets. The workers have to round the entire street just to ensure the street lights are in good condition. Usually, they do this activity at night. Sometime, TNB have to hire the outside contractor just to help their workers because they lack of the manpower. Unfortunately, this method will adverse the company because they need to spend a lot of money to hire contractor.

The other method of monitoring the street lights is through complaints from customers. The customer can report their complaint via TNB's website or directly contact to service online provided by TNB. With service online, customer should know their pole number stated in electric bill receipt so it would be easy for TNB to do the maintenance.

This method is reactive in nature because street light repair only carry out after customer lodge a complaint.

1.3 Objective

To locate the unlighted street light by using impedance base method algorithm.

1.4 Scope of Study

The scopes of this project are:-

- Understand the street lighting system practiced by TNB
- Review the impedance base method.
- Review of the projects that have been done by other people.
- Create a prototype of street lighting.
- Measurement of voltage and current.
- Come out with the algorithm.

1.5 Reliability and Feasibility of the Project

Actually, this project will make TNB easier to do their work. They do not have to check for all street light at all area. They also can save more money instead of hire a contractor. It is better to use their money to improve their service. Furthermore, what more important is they can save more time and be more efficient.

CHAPTER 2
LITERATURE REVIEW

2.1 The Street Lighting System

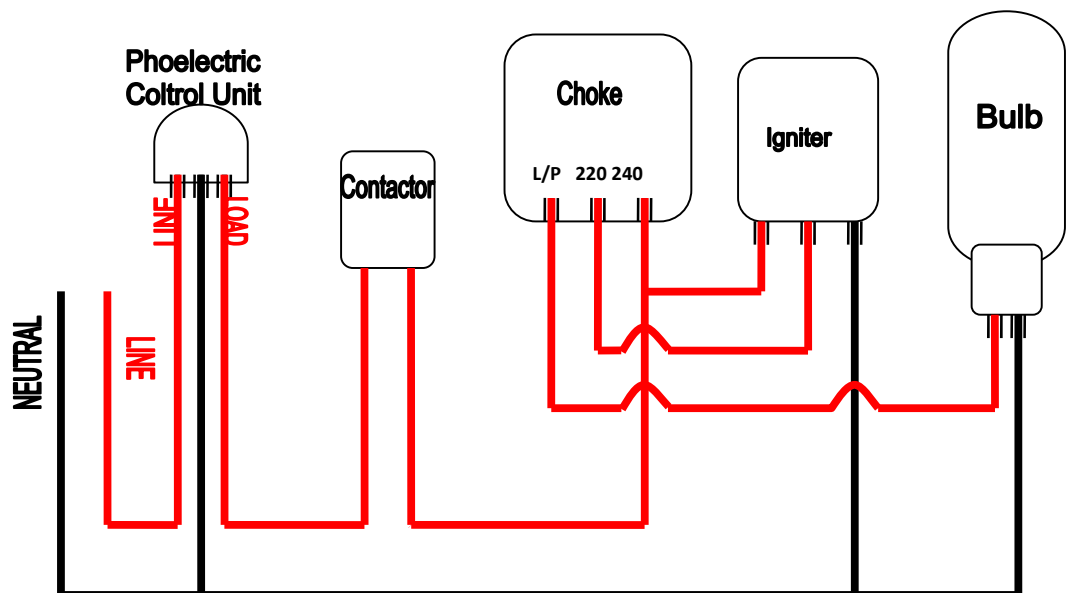

Figure 1 Street lighting wiring circuit

2.1.1 Function of street lighting component:

(1) Photoelectric control unit or Photocell

It will function as a time switch. It will connect the supply to street lighting conductor when light intensity below the set level [3].

(2) Contactor

It will function as a relay switch [3].

(3) Choke

It will increase the initial voltage and limit the current flow [3].

(4) Igniter

It will function as a starter where it will increase the initial voltage to make the lamp light up [3].

When the light intensity becomes low, photocell will detect it. Then, contactor will function as a switch and will connect to choke. Here, choke will limit the amount of current flow. Next, the current will flow to igniter and it will increase the amount of voltage in order to make the light lighted.

2.2 Current Level Detection Method to Locate Faulty of Street Lighting

One of the methods used to locate faulty at street lighting system is by using drop in current at the main junction before it flows to each lamp and indicate any street lighting failure just by looking at the control panel [4]. The basic idea of this method is using Kirchoff's Current Law (KCL) where at any node (junction) in an electrical circuit the sum of currents flowing into that node is equal to the sum of currents flowing out of the node [6]. This method shows the sum of current use by each bulb is same as the current at the main junction which is at the control panel before current flows into each bulb [4].

In this project, Programmable Interface Controller (PIC) Microcontroller has been used to display the number of unlighted utility street lighting system on LED correspondingly depending on the AC Current Sensor output [4].

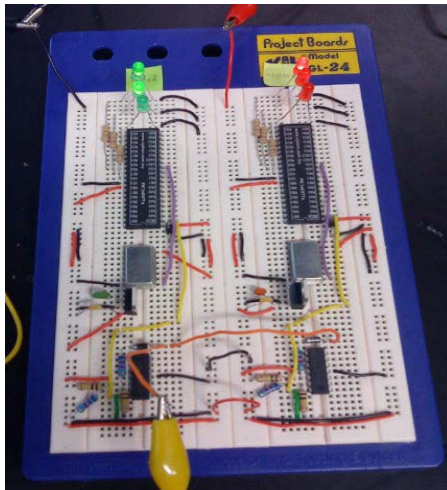

Figure 2 Circuit constructed for lighted and unlighted part [4].

The advantage of this method is that LED is used to represents the number of unlighted street light. We can know the number of unlighted street light just by counting the number of lighted LED [4]. So, this method can only detect how many lights are unlighted but it cannot locate exactly which light is unlighted.

2.3 Method of Locating Faulty Street Lighting using Wireless Sensor Network (WSN)

The other method to locate faulty of street lighting system is using wireless sensor network. A sensor is developed and to be placed at a street light. The method concerns about the communications between a few sensors, one on a street light with another one on a different street light. The transmission uses a device that can do multihop transmission as well as have the power saving function [5].

These techniques have recently been made feasible by advances in micro power, RF communication and ubiquitous power collection which bring forth the XBee RF Module. All of the XBee RF Modules attached to the sensors are distinguished by a unique Identification Number (ID) number given to each of them. Then s Graphic User Interface (GUI) is developed in order to monitor the sensors from a local monitoring centre [5].

The advantage of this method is we can locate faulty street lighting. The disadvantages of this method are it is costly to install WSN at every pole and high maintenance cost to repair the WSN battery at each pole.

2.4 Distance Protection Relay

Distance protection relay normally used at transmission line. Distance relay essentially looks at the impedance of the circuit to be protected. When a fault occur the impedance of the circuit will change. It then calculates this new impedance to determine where the fault has occurred. By knowing where the fault is, it can trip appropriate CB's to isolate the faulted section [7].

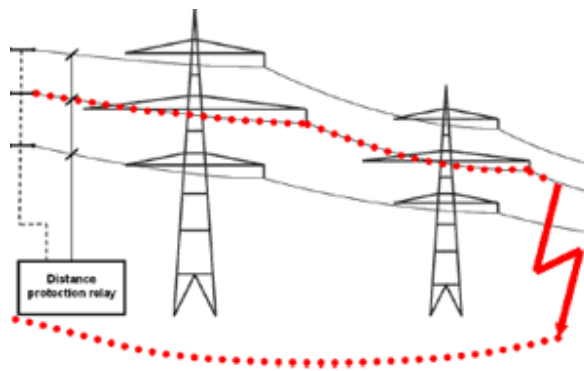

Figure 3 Distance Protection Relay

Distance relay also known as impedance relay because distance is proportional to the impedance of the line. Apparent impedance calculated is compared with reach point impedance. If the measured impedance is less than the reach point impedance, it is assumed that a fault exists on the line between relay and reach point.

$$\frac{E_x - E_y}{I_x - I_y} = Z_1$$
, where x and y can be phase a, b, or c and Z_1 is the positive sequence impedance between the relay location and the fault [8].

CHAPTER 3

METHODOLOGY

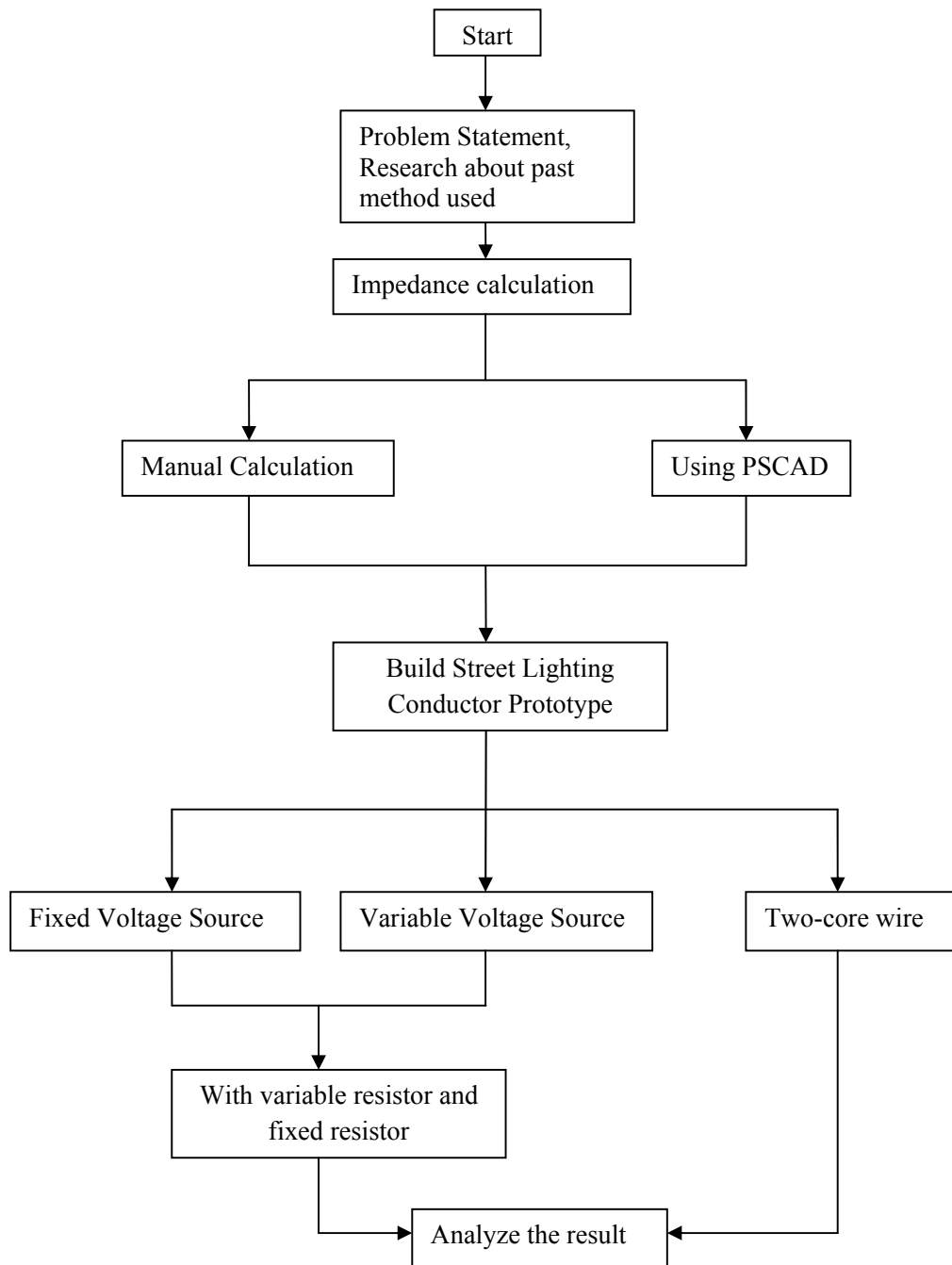

Figure 4 Flow Chart for methodology

3.1 Impedance Base Algorithm

In this project, impedance base method is introduced in order to get a correct algorithm to locate faulty of street light. Assumption in this project is when the light is unlighted there will be no current flow through it.

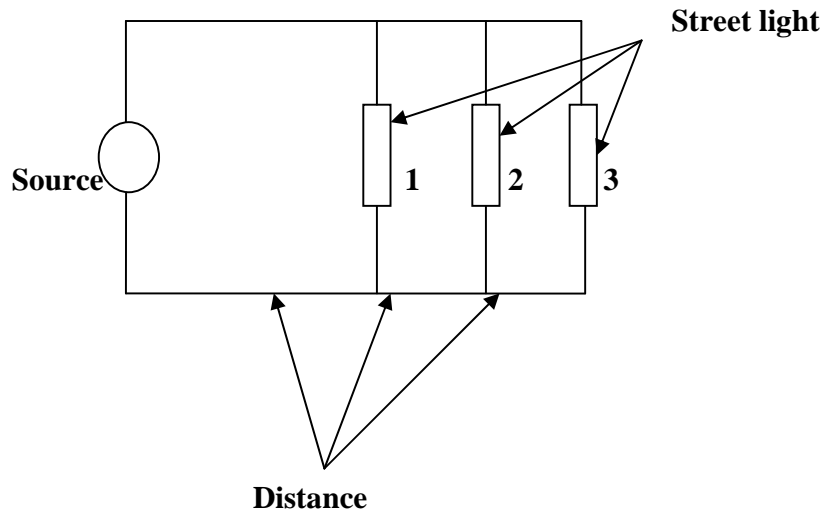

Figure 5 Circuit diagram for Impedance Base Algorithm

The measurements that have to be considered are voltage and current. The voltage and current are measured at control panel at the beginning of street lighting system. When all the lights are lighted up, the impedance value should be the lowest because the measured current is high. Then, if the first light is unlighted where the other two lights are lighted, the impedance should be higher than when all lights are lighted. If the second light is unlighted, the impedance should be less than the first light is unlighted. When the third light is unlighted, the impedance value will be decrease even added more street light. The impedance should be inversely proportional to the value of current.

Before that, there are some parameters required before doing the calculation and experiment which are:

- Distance between each street light which is usually 40 meter.
- Cable resistance used in street light and neutral conductors are 0.0995Ω and 0.1165Ω respectively.
- TNB supply voltage which is 240 V.

After getting the impedance value, what is more important is to create an algorithm. Impedance alone will give close value between the same numbers of unlighted street light which is difficult to differentiate. Therefore impedance ratio factor was introduced which is:

$$\text{Impedance Ratio Factor (IRF)} = \frac{\text{Impedance during partial unlighted}}{\text{Impedance during full lighted}}$$

Since impedance is different for every unlighted street light, their IRF should be different and easy to recognize. This IRF will be used at the last part of the experiment when using two-core wire.

3.2 Manual Calculation for Impedance

The value of current and impedance were found from calculation by using manual calculation based on this circuit:

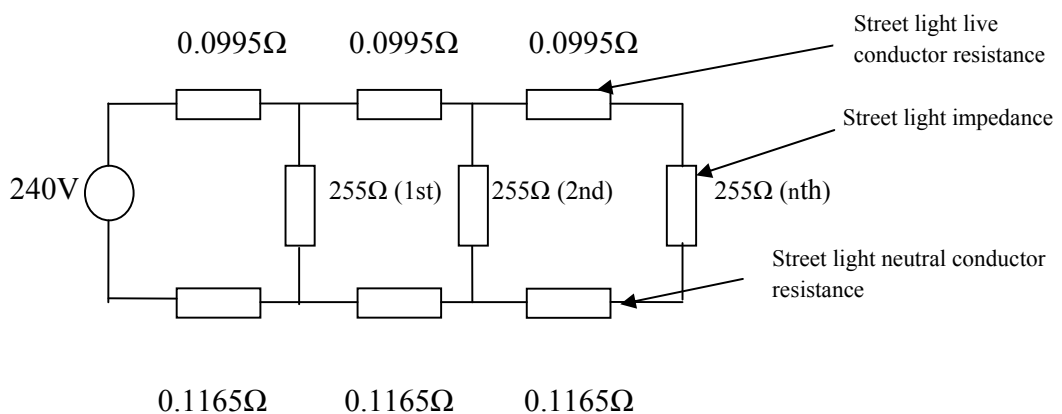

Figure 6 Circuit diagram for manual calculation

3.3 PSCAD Simulation for Impedance

Besides hand calculation, software that also can be used is PSCAD. This software can do simulation and can show the voltage and current value. Impedance and IRF can be obtained from the voltage and current. The voltage also can be varying by using this software.

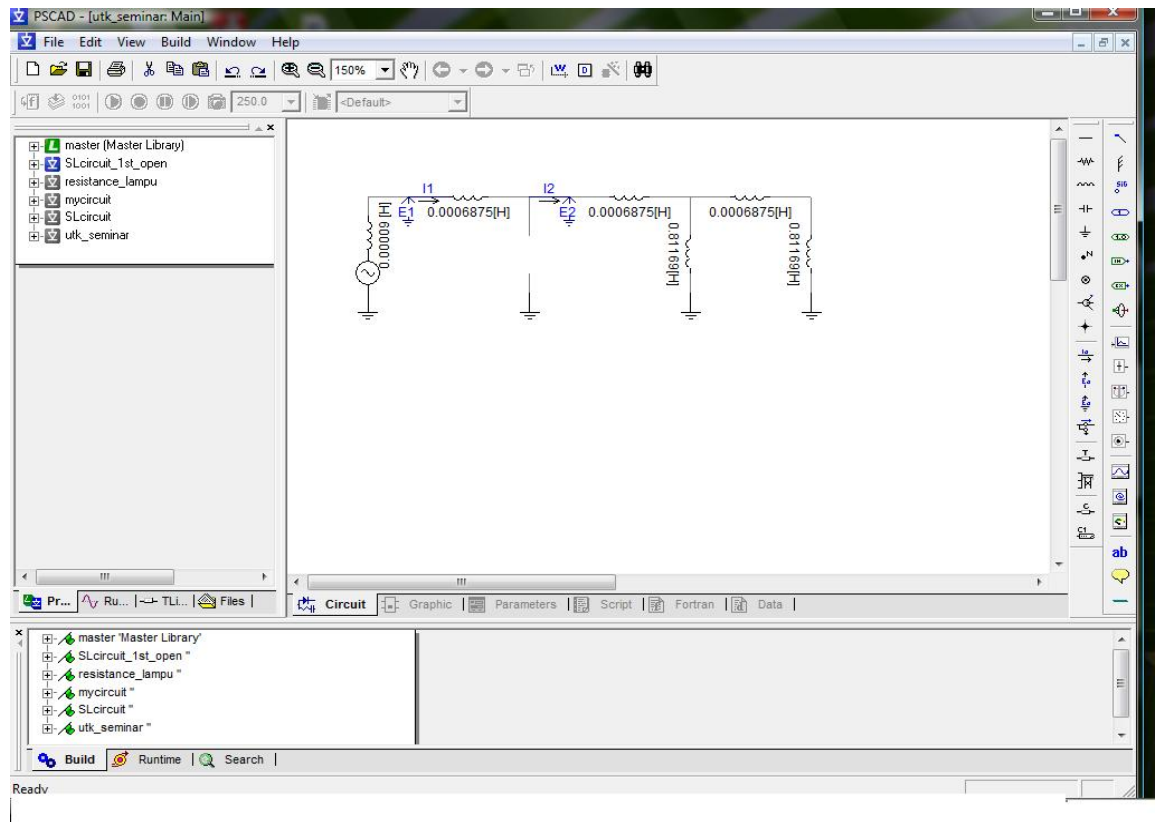

Figure 7 Example of PSCAD view

3.4 Prototype of Street Lighting Conductors

The three lights prototype was build to establish impedance based algorithm. We have chosen the fluorescent light to represent the real street light. The prototype for street lighting is showed as below.

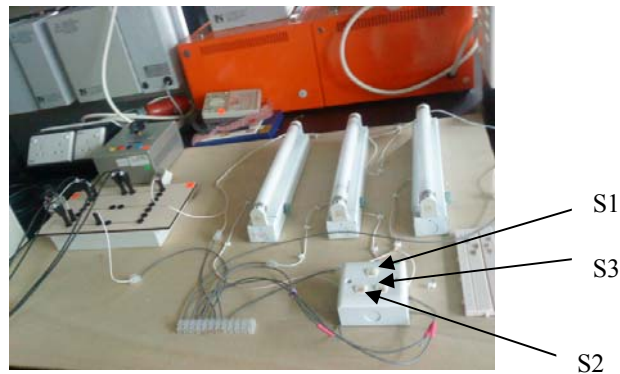

Figure 8 Street Lighting Conductor Prototype

As shown in Figure 9, from left is a first light, second light and third light at the most right. So, switch S1 will control for first light, switch 2 will control the second light and switch 3 will control the third light.

In order to conduct the experiment, six cases were introduced which are:

Table 1 Description for six cases

Case	Description
1	First light unlighted, second and third light lighted
2	Second light unlighted, first and third light lighted
3	Third light unlighted, first and second light lighted
4	First and second light unlighted, third light lighted
5	First and third light unlighted, second light lighted
6	Second and third light unlighted, first light lighted

3.4.1 Fixed Voltage Source with Variable Resistor

Firstly, the prototype of street lighting conductors is modified as shown in Figure 9. Decade resistance block is used to represent the value of varying street light distance. Here, the value of resistance is varying from 1Ω , 2Ω , 3Ω , 4Ω , 5Ω .



Figure 9 Prototype with decade resistance block

3.4.2 Fixed Voltage Source with Fixed Resistor

Secondly, fixed resistor with two different values which are 0.22Ω and 0.1Ω is used. These two values are actually representing the real street lighting and neutral conductor impedance respectively. The prototype is shown in Figure 11.



Figure 10 Prototype using breadboard

For this experiment, breadboard is used to connect the resistor. Unfortunately, using breadboard for voltage 230 V is not recommended. Therefore, connector is used for safety reason.

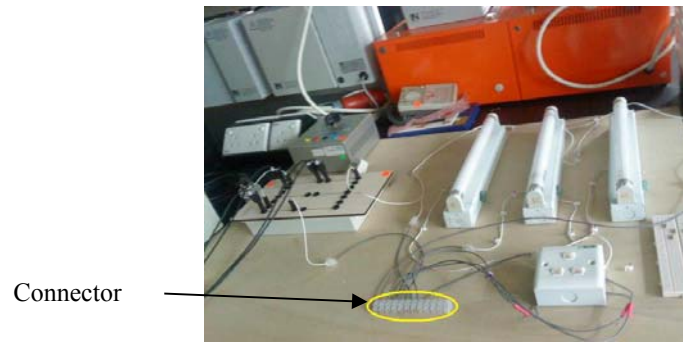

Figure 11 Prototype with using connector

Voltage and current is measured by using multimeter and Data Acquisition (DAQ).

3.4.3 Variable Voltage Source with Fixed Resistor

Since TNB declared for low voltage is +5% and -10%, these voltages should be used as variable voltage respectively. The voltages that have been chosen are:

Table 2 Percentage of voltage applied

Voltage, V	Percentage, %
207	-10.0
210	-8.70
215	-6.52
220	-4.35
228	-0.87
232	+0.87
235	+2.17
237	+3.04
240	+4.35
241.5	+5.00

Variable auto transformer is used to step up or down the voltage. So it easy to control the voltage value and make it fixed [9],[10].



Figure 12 Variable auto transformer

3.4.4 Two-core wire

Finally, two-core wire is used to replace the resistor. The total length for wire used is 150 meter where 50 meter between each light. This time, measurement is made using multimeter.



Figure 13 Prototype using multi-coil wire

CHAPTER 4

RESULT AND DISCUSSION

4.1 Manual Calculation for Impedance

For the manual calculation, 20 streets light have been used. It is actually to see the pattern when many lights involved.

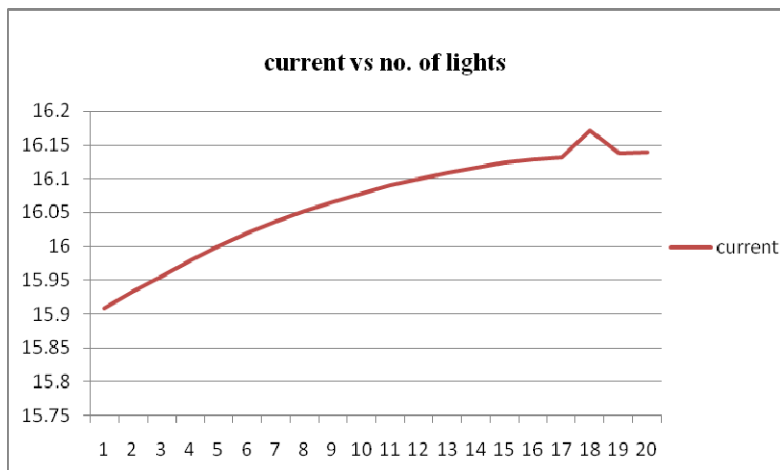

Figure 14 Graph for current versus number of lights

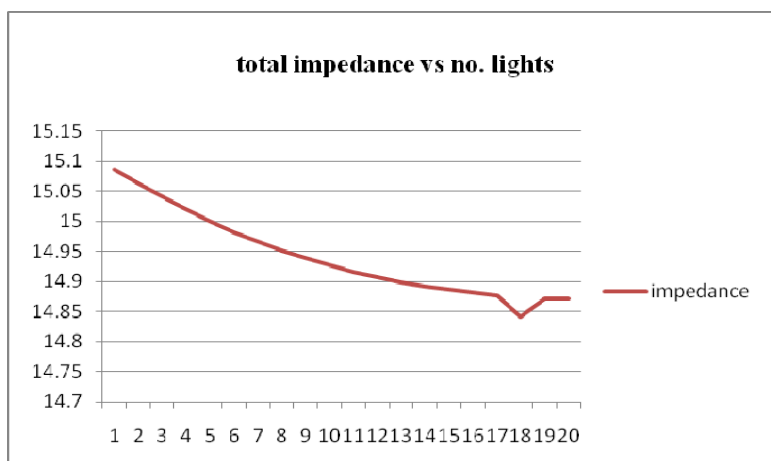

Figure 15 Graph for total impedance versus number of lights

As it clearly see in Figure 14, the pattern of this graph is constantly increase until eighteenth light but it suddenly decrease for nineteenth light and increase back when it approach twentieth light.

Same goes to Figure 15, the pattern of this graph is constantly decrease until branch eighteenth light but it suddenly increase for nineteenth light and decrease back when it comes to twentieth light.

The voltage used here is 230 V. This is actually not an ideal condition because the voltage at real street lighting not necessarily 230 V all the time.

4.2 PSCAD simulation for impedance

By using PSCAD, we can simulate and determine value of voltage and current. In PSCAD, it can simulate up 40 lights but it is limited to simulate only 15 nodes for student license. Hence, simulation is done up till 14 nodes only.

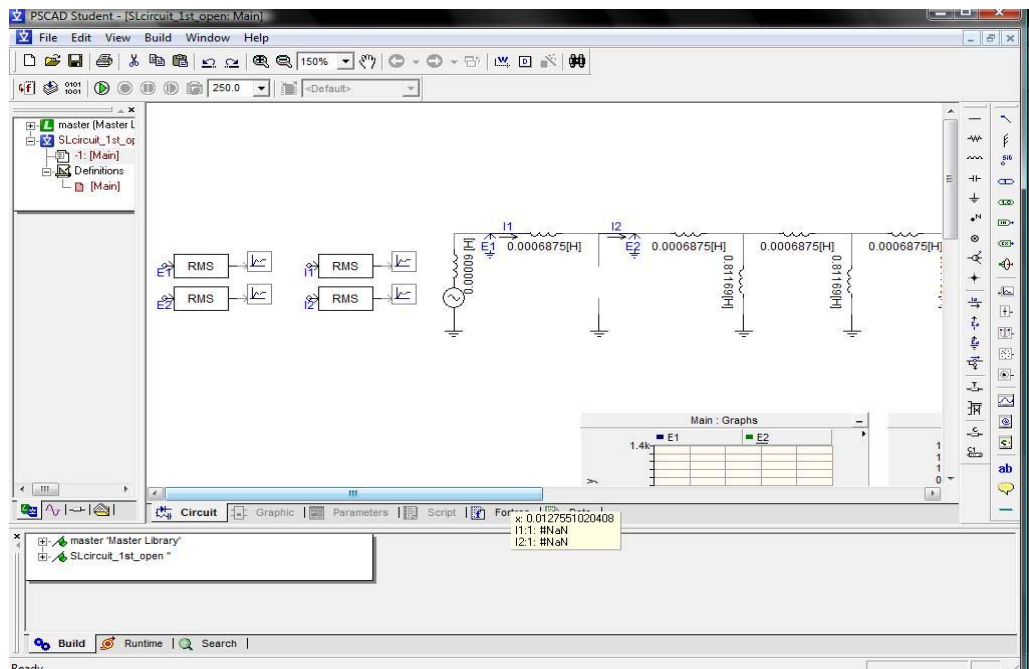

Figure 16 Circuit diagram using PSCAD

Simulation is done for 14 lights to compare with hand calculation.

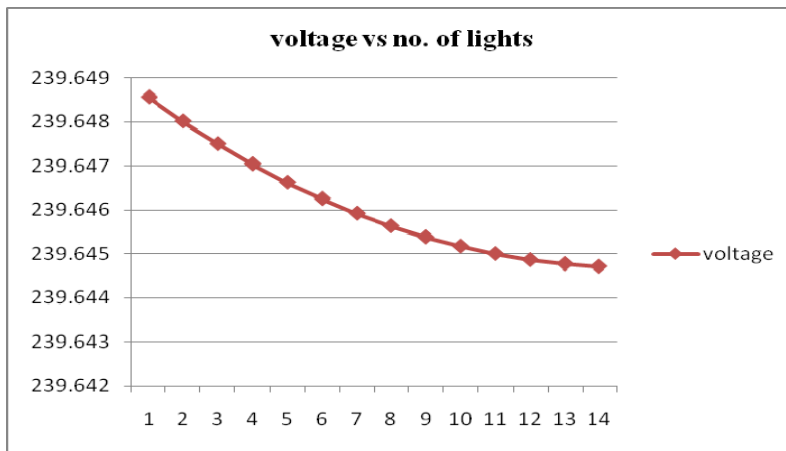

Figure 17 Graph for voltage versus number of lights

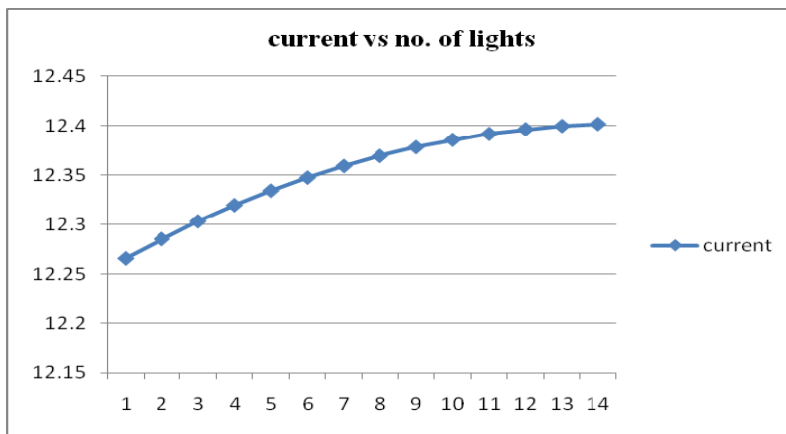

Figure 18 Graph for current versus number of lights

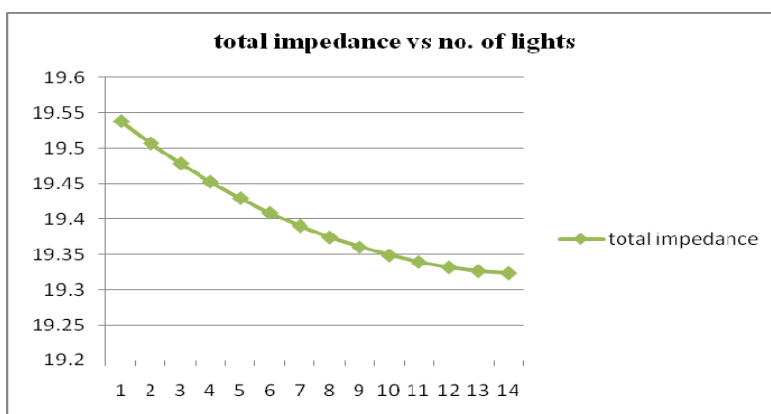

Figure 19 Graph for total impedance versus number of lights

Figure 17 shows graph for voltage versus number of lights where the value of voltage decreasing as the number of light increasing. In Figure 18, the value of current is increasing while the number of lights increasing. Last but not least, Figure 19 shows the total impedance is decreasing corresponding when number of rising lights.

4.3 Fixed Voltage Source with Variable Resistor

- For $R=1\Omega$:

Table 3 Result for $R=1\Omega$

Case	Voltage	Current	Impedance
1	239.5	0.43333	552.692
2	239.5	0.436	549.312
3	239.733	0.43167	555.367
4	239.633	0.21967	1090.9
5	239.567	0.21467	1115.99
6	239.8	0.219	1094.98

- For $R=2\Omega$:

Table 4 Result for $R=2\Omega$

Cases	Voltage	Current	Impedance
1	239.533	0.43	557.054
2	239.4	0.43567	549.503
3	239.433	0.42933	557.686
4	239.533	0.219	1093.76
5	239.733	0.214	1120.25
6	239.633	0.218	1099.24

- For $R=3\Omega$:

Table 5 Result for $R= 3\Omega$

Cases	Voltage	Current	Impedance
1	239.333	0.42933	557.453
2	239.433	0.43367	552.114
3	239.333	0.429	557.887
4	239.6	0.21867	1095.73
5	239.633	0.21367	1121.53
6	239.5	0.217	1103.69

- For $R=4\Omega$:

Table 6 Result for $R= 4\Omega$

Cases	Voltage	Current	Impedance
1	239.267	0.42667	560.781
2	239.433	0.43167	554.672
3	239.6	0.42667	561.563
4	239.8	0.21767	1101.68
5	239.567	0.21333	1122.97
6	239.167	0.21533	1110.68

- For $R=5\Omega$:

Table 7 Result for $R= 5\Omega$

Cases	Voltage	Current	Impedance
1	239.4	0.42633	561.532
2	239.467	0.43067	556.037
3	239.567	0.42667	561.484
4	239.6	0.21733	1102.45
5	236.5	0.21233	1113.81
6	239.4	0.216	1108.33

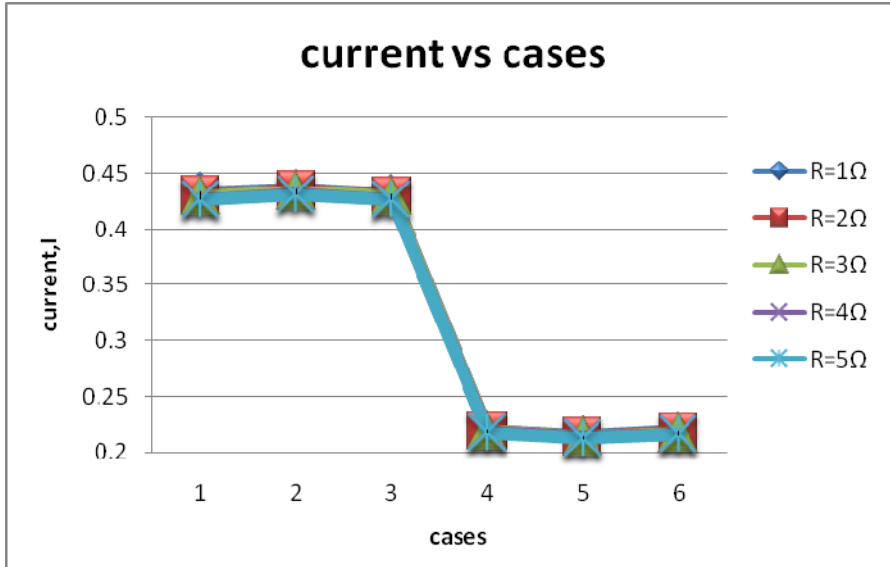

Figure 20 Current graph for 1Ω, 2Ω, 3Ω, 4Ω, and 5Ω.

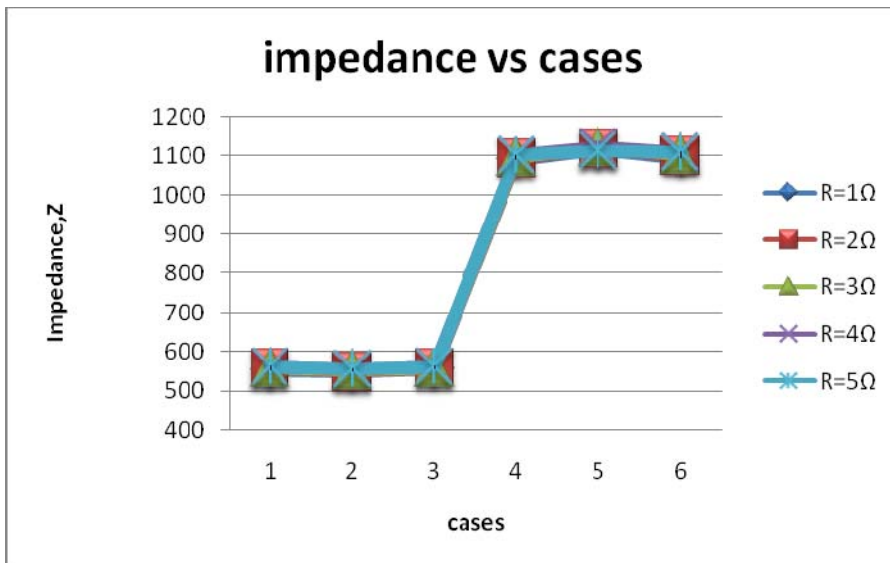

Figure 21 Impedance graph for 1Ω, 2Ω, 3Ω, 4Ω, and 5Ω.

For Figure 20, it shows current value for 1Ω, 2Ω, 3Ω, 4Ω, and 5Ω. It is clearly shown that the current will slightly increase from case 1 to case 2 while it will decrease for case 3. For case 5, current will decrease from case 4 and it will decrease back for case 6.

For figure 21, it shows impedance value for 1Ω, 2Ω, 3Ω, 4Ω, and 5Ω. The graph for impedance should be inversed to current graph. The impedance for case 2 is lower than case 1 and it will increase back for case 3. For case 5, impedance is high compared to case 4 and it will decrease back for case 6.

So, there are overlapping occur between case 1 and case 3. Same goes to case 4, it also overlaps with case 6.

4.4 Fixed Voltage Source with Fixed Resistor

- Using Multimeter:

Table 8 Result for six cases using multimeter

Cases	Voltage	Current	Impedance
1	239.67	0.4377	547.625
2	239.66	0.438	547.161
3	239.65	0.4313	555.615
4	239.66	0.221	1084.450
5	239.65	0.2157	1111.227
6	239.66	0.2177	1101.031

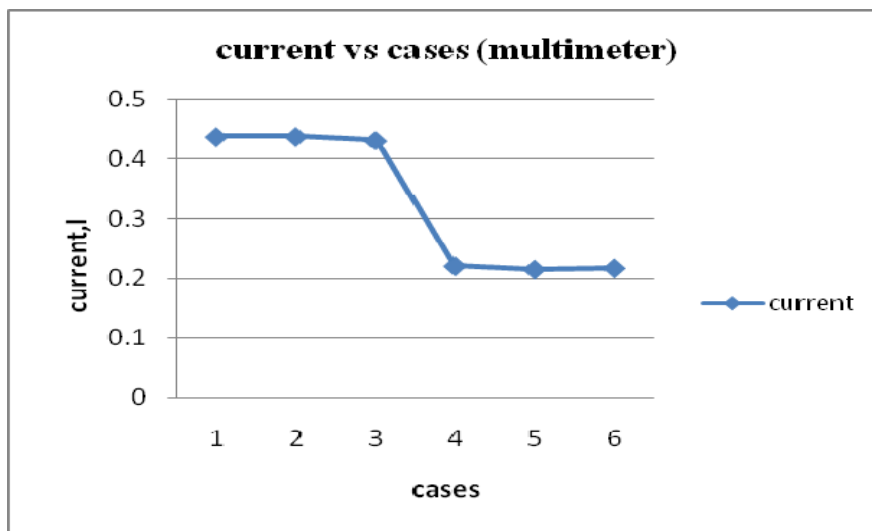

Figure 22 Current graph using multimeter

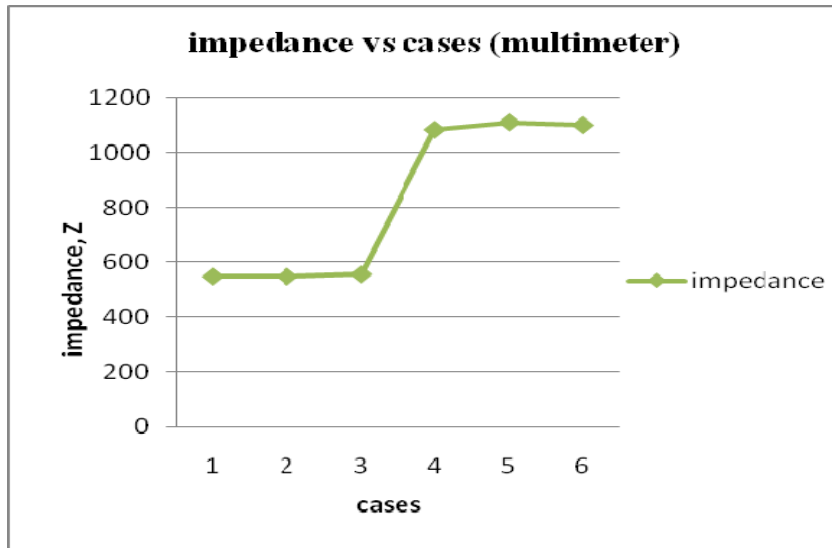

Figure 23 Impedance graph using multimeter

For Figure 22, it shows current value when using fixed resistor. It is clearly shown that the current will slightly increase from case 1 to case 2 while it will decrease for case 3. For case 5, current will decrease from case 4 and it will decrease back for case 6.

For Figure 23, it shows impedance value when using fixed resistor. The graph for impedance should be inversed to current graph. The impedance for case 2 is lower than case 1 and it will increase back for case 3. For case 5, impedance is high compared to case 4 and it will decrease back for case 6.

There are still overlapping occur between case 1 and case 3. Same goes to case 4, it also overlaps with case 6.

- Using Data Acquisition (DAQ):

Table 9 Result for six cases using DAQ

Cases	Voltage	Current	Impedance
1	227.8	0.100	2278.0
2	227.8	0.100	2278.0
3	227.8	0.099	2301.01
4	227.7	0.0513	4438.596
5	227.8	0.0497	4583.501
6	227.7	0.050	4554.00

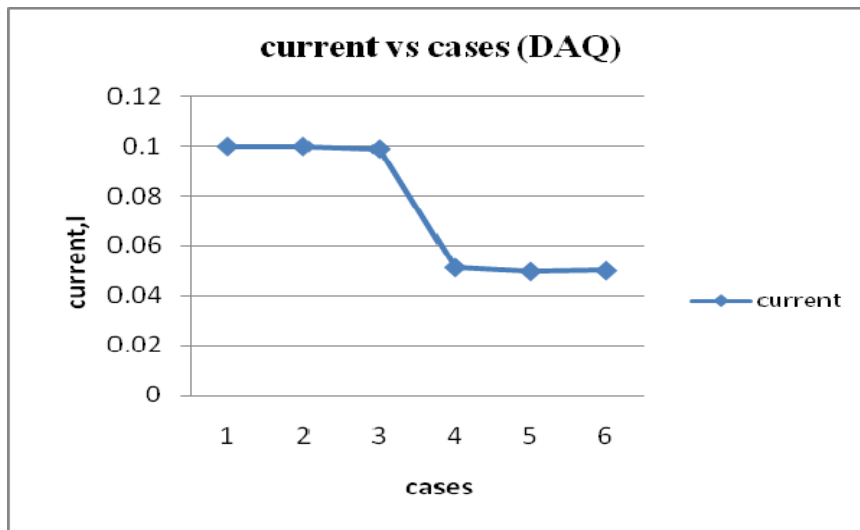

Figure 24 Current graph using DAQ

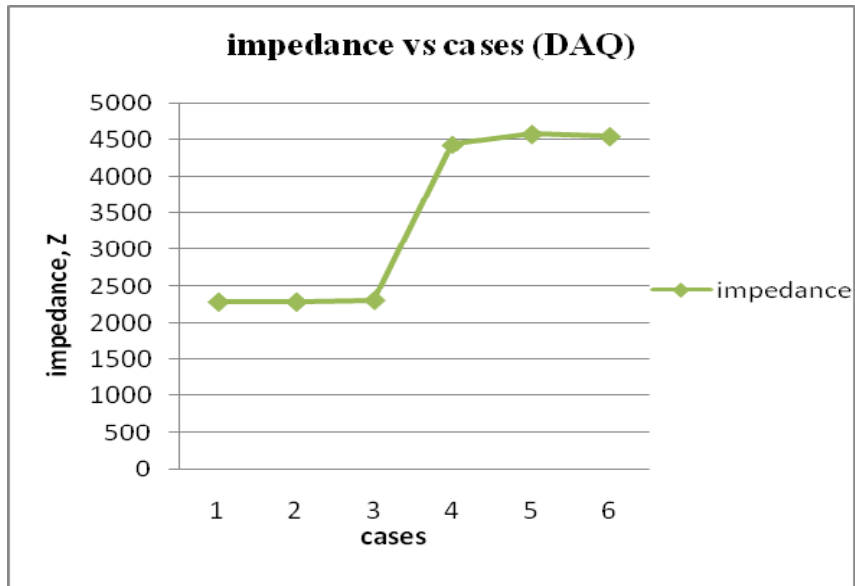

Figure 25 Impedance graph using DAQ

For Figure 24, the value of current is decrease as followed by each case and it will inversed to Figure 25 for impedance. The measurement is made by using multimeter because it can show more than 4 decimal places whereas the DAQ can show only 2 decimal places. It is important to know more decimal places because overlapping may occur if measurement less decimal places.

Overlapping still occur eventhough used of fixed resistor. So, it is difficult to create an algorithm since the value of impedance still overlapping.

4.5 Variable Voltage Source with Fixed Resistor

- 207 V:

Table 10 Result for six cases using 207 V

Cases	Current	Impedance
1	0.322	642.8571
2	0.334	619.7605
3	0.317	652.9968
4	0.163	1269.939
5	0.159	1301.887
6	0.16	1293.75

- 210 V:

Table 11 Result for six cases using 210 V

Cases	Current	impedance
1	0.33	636.3636
2	0.331	634.4411
3	0.326	644.1718
4	0.167	1257.485
5	0.162	1296.296
6	0.163	1288.344

- 215 V:

Table 12 Result for six cases using 215 V

Cases	Current	Impedance
1	0.345	623.1884
2	0.348	617.8161
3	0.344	625
4	0.174	1235.632
5	0.17	1264.706
6	0.171	1257.31

- 220 V:

Table 13 Result for six cases using 220 V

Cases	Current	Impedance
1	0.357	616.2465
2	0.359	612.8134
3	0.355	619.7183
4	0.181	1215.47
5	0.176	1250
6	0.177	1242.938

- 228 V:

Table 14 Result for six cases using 228 V

Cases	Current	Impedance
1	0.386	590.6736
2	0.387	589.1473
3	0.383	595.3003
4	0.195	1169.231
5	0.191	1193.717
6	0.192	1187.5

- 232 V:

Table 15 Result for six cases using 232 V

Cases	Current	Impedance
1	0.399	581.454
2	0.400	580.000
3	0.396	585.859
4	0.203	1142.857
5	0.200	1159.346
6	0.201	1154.229

- 235 V:

Table 16 Result for six cases using 235 V

Cases	Current	Impedance
1	0.415	566.265
2	0.414	567.633
3	0.409	574.572
4	0.208	1129.808
5	0.203	1157.635
6	0.206	1140.777

- 237 V:

Table 17 Result for six cases using 237 V

Cases	Current	Impedance
1	0.464	510.776
2	0.467	507.495
3	0.459	516.340
4	0.236	1004.237
5	0.228	1039.474
6	0.234	1012.821

- 240 V:

Table 18 Result for six cases using 240 V

Cases	Current	impedance
1	0.438	547.945
2	0.439	546.697
3	0.435	551.724
4	0.222	1081.081
5	0.217	1105.991
6	0.219	1095.890

- 241.5 V:

Table 19 Result for six cases using 241.5 V

Cases	Current	impedance
1	0.447	540.268
2	0.449	537.862
3	0.441	547.619
4	0.225	1073.333
5	0.220	1097.727
6	0.222	1087.838

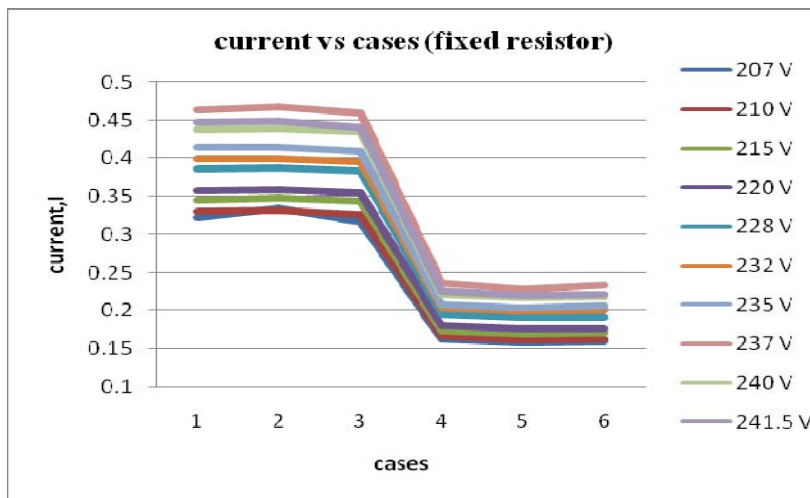

Figure 26 Current graph using fixed resistor

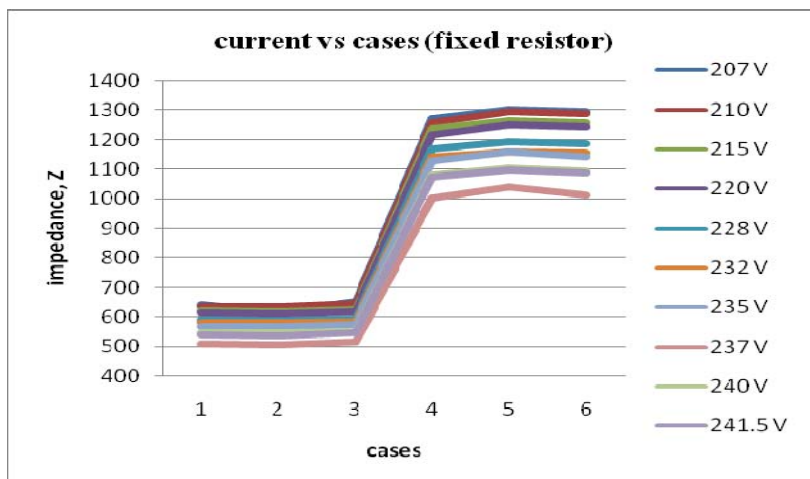

Figure 27 Impedance graph using fixed resistor

For current graph at Figure 26, the value will decrease from the first case until sixth case. For impedance graph at Figure 27, it is inversely to current graph where the value will increase from the first case until seventh case.

However, there is still a small different of impedance value between each cases. It will give a difficulty to differentiate the impedance value for every case.

The problem comes when the value of resistance for street light and neutral conductors from TNB is only resistance, R value. In theory, the value of conductor impedance normally resistance, R and reactance, X. So, in this project, reactance, X is ignored. If there is reactance value, the impedance should be more different and it may be easier to locate which light is unlighted or lighted.

So, the other way to continue this project is by using real distance applied in real site which is 50 meter between each street light. Two-core wire has been used for the street light conductor.

4.6 Two-core wire

Finally, two-core wire is used to replace the resistor. The result for current is shown as below:

Table 20 Result for six cases using 207 V

Cases	Current	impedance
1	0.308	672.0779
2	0.3167	653.6154
3	0.3071	674.0475
4	0.1596	1296.992
5	0.1502	1378.162
6	0.1583	1307.644

Table 21 Result for six cases using 210 V

Cases	Current	impedance
1	0.3137	669.4294
2	0.3239	648.3483
3	0.3132	670.4981
4	0.1631	1287.554
5	0.153	1372.549
6	0.1621	1295.497

Table 22 Result for six cases using 215 V

Cases	Current	impedance
1	0.3243	662.9664
2	0.3358	640.2621
3	0.3248	661.9458
4	0.1687	1274.452
5	0.158	1360.759
6	0.1681	1279.001

Table 23 Result for six cases using 220 V

Cases	Current	impedance
1	0.3384	650.1182
2	0.3508	627.138
3	0.3393	648.3938
4	0.1761	1249.290
5	0.1653	1330.913
6	0.1763	1247.873

Table 24 Result for six cases using 228 V

Cases	Current	impedance
1	0.3613	631.0545
2	0.3754	607.3522
3	0.3629	628.2723
4	0.1888	1207.627
5	0.1760	1295.455
6	0.1900	1200.000

Table 25 Result for six cases using 232 V

Cases	Current	impedance
1	0.4240	547.1698
2	0.3952	587.0445
3	0.4227	548.8526
4	0.1987	1167.589
5	0.2290	1013.100
6	0.1988	1167.002

Table 26 Result for six cases using 235 V

Cases	Current	impedance
1	0.4386	535.7957
2	0.4082	575.6982
3	0.4390	535.3075
4	0.2052	1145.2240
5	0.2377	988.6411
6	0.2055	1143.552

Table 27 Result for six cases using 237 V

Cases	Current	impedance
1	0.4481	528.8998
2	0.4162	569.4378
3	0.4494	527.3698
4	0.2098	1129.6470
5	0.2441	970.9136
6	0.2104	1126.4260

Table 28 Result for six cases using 240 V

Cases	Current	impedance
1	0.4660	515.0215
2	0.4307	557.2324
3	0.4656	515.4639
4	0.2174	1103.9600
5	0.2532	947.8673
6	0.2177	1102.4350

Table 29 Result for six cases using 241.5 V

Cases	Current	impedance
1	0.4738	505.7087
2	0.4392	549.8634
3	0.4741	509.3862
4	0.2214	1090.7860
5	0.2577	937.1362
6	0.2224	1102.4350

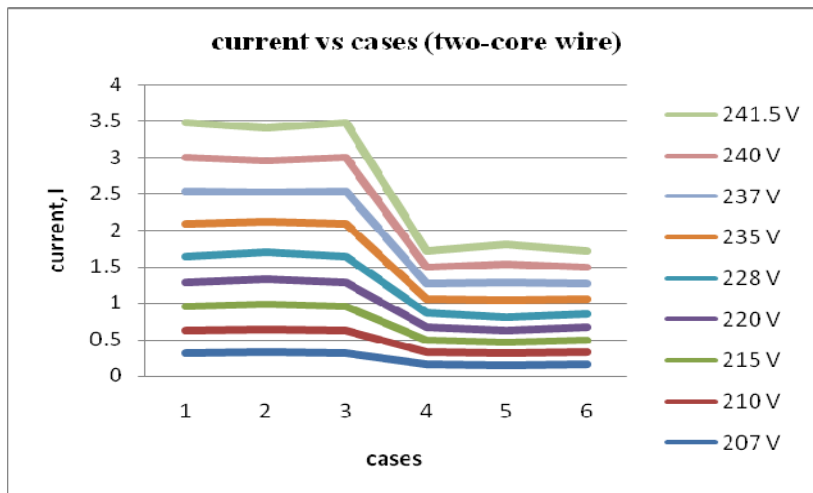

Figure 28 Current graph using two-core wire

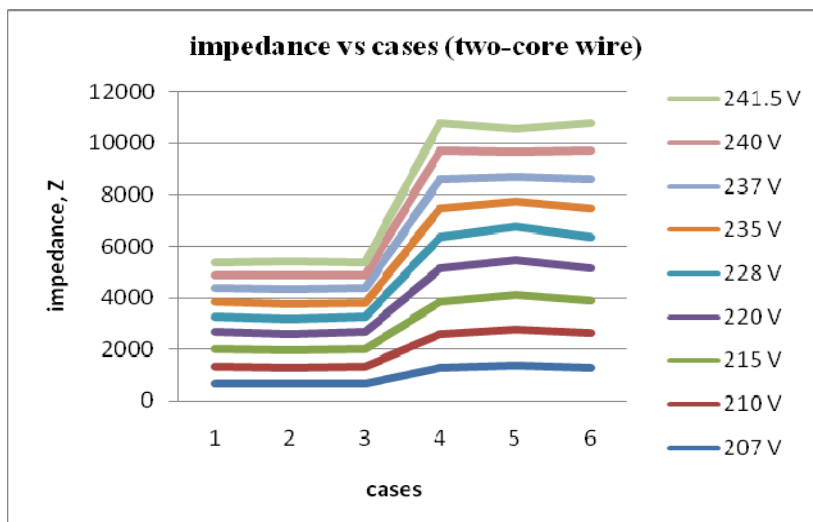

Figure 29 Impedance graph using two-core wire

For current graph at Figure 28, the value will decrease from the first case until seventh case. For impedance graph at Figure 29, it is inversely to current graph where the value will increase from the first case until seventh case.

Pattern of the current graph for all cases is the same even though the voltage is increase. Same goes to impedance graph, the pattern is the same for all case while the voltage is increasing.

Back to main objective where need to come out with algorithm to differentiate the value of impedance. In order to do that, Impedance Ratio Factor (IRF) value is introduced where division of impedance during partial unlighted with impedance during full lighted. By getting IRF factor, it will be easier to detect any overlapping of impedance for all cases.

Impedance Ratio Factor (IRF) is shown in Table 30 below.

Table 30 Impedance Ratio Factor (IRF)

Impedance Ratio Factor (IRF)										
Case	207V	210V	215V	220V	228V	232V	235V	237V	240V	241.5V
1	1.507143	1.509404	1.511255	1.511820	1.515638	1.455189	1.406749	1.455702	1.452575	1.449135
2	1.46574	1.461871	1.45950	1.458381	1.458711	1.561235	1.511514	1.567275	1.571628	1.563297
3	1.51156	1.511814	1.508929	1.507810	1.508956	1.459664	1.405467	1.451491	1.453823	1.448218
4	2.908521	2.903127	2.905157	2.905168	2.900424	3.105184	3.006823	3.109152	3.113615	3.101174
5	3.090546	3.094771	3.101899	3.094979	3.111364	2.694323	2.595709	2.672254	2.673381	2.664338
6	2.932407	2.921036	2.915526	2.901871	2.882105	3.103622	3.002433	3.100285	3.109325	3.087230

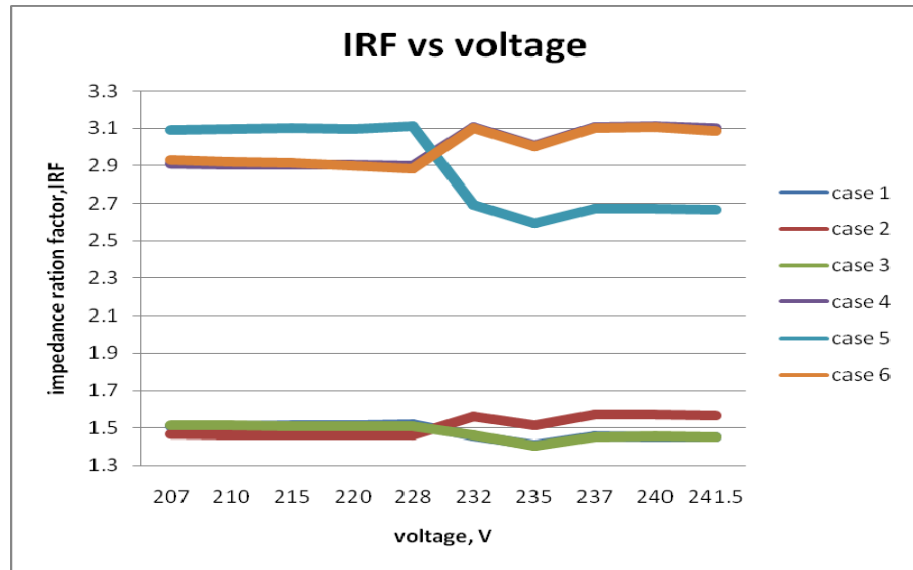

Figure 30 Graph for Impedance Ratio Factor (IRF)

As shown in Figure 30, overlapping occur between case 1 and case 3 which is when first light unlighted, second and third light lighted and when third light unlighted, first and second light lighted. This happened because the pattern of current value is decrease and increase back suddenly. So, it must be overlapping for IRF value.

Another overlapping occur between case 4 and case 6 which is when third light lighted, first and second light unlighted and when first light lighted, second and third light unlighted. Same goes for previous case where the pattern of current value is decrease and increase back suddenly. So, it must be overlapping for IRF value.

Another reason for overlapping IRF during this experiment, the wire are coil. This may introduce additional inductance in the conductor impedance. The street light conductor should be string not coil. It is better if this experiment is done by added more lights up until six or seven light so it will be easier to analyze the result.

CHAPTER 5

CONCLUSION & RECOMMENDATION

5.1 Conclusion

The impedance base algorithm can detect failure of street light between first light and second light because there is no overlapping Impedance Ratio Factor (IRF) value for first and second light. It also can detect failure between second light and third light since there is no overlapping of IRF here.

Next, for two lights unlighted at one time, this method can detect failure between the third light lighted, first and second light unlighted and when first light lighted, second and third light unlighted. It also can detect failure when the second light lighted, first and third light unlighted and when first light lighted, second and third light unlighted.

Essentially, this method can detect two failure occur at one time but it cannot differentiate exactly which light is actually unlighted. Same goes to combination of two lights where it can detect the two combinations in failure but cannot differentiate which combination it is.

5.2 Recommendation

To make this project more successful, the using wire should not be coiled. It is better if the wire is stretch so there will no unwanted resistance that can make this project failed.

Other than that, this project can be applied for more lights instead of using three lights only. It is because if more lights are use, the difference of impedance and current can be seen clearly.

REFERENCES

- [1] http://en.wikipedia.org/wiki/Street_light#History
- [2] <http://houseconstructionindia.blogspot.com/2010/04/lamps-sodium-vapour-lamps.html>
- [3] note from ilsas- penjangkaan lampu awam
- [4] Nur Afifah Bt Mohd Ramli, June 2010, Method of Detecting Unlighted Utility Street Lighting System
- [5] Zul Zarif Sharkawi, November 2010, Intelligent Street Light Monitoring System Using Wireless Sensor Network
- [6] http://en.wikipedia.org/wiki/Kirchhoff's_circuit_laws
- [7] http://wiki.answers.com/Q/How_does_a_distance_protective_relay_work
- [8] <http://www.fecime.org/referencias/npag/chap11-20-170-191.pdf>
- [9] <http://en.wikipedia.org/wiki/Transformer>
- [10] <http://www.wisegeek.com/what-is-an-autotransformer.htm>

APPENDIX

No	Detail/ Week	1	2	3	4	5	6	7		8	9	10	11	12	13	14	
1	Selection of Project Topic								Mid-semester break								
2	Preliminary Research Work																
3	Submission of Preliminary Report																
4	Project Work, Research on Hardware Design																
5	Submission of Progress Report																
6	Seminar																
7	Project Work Continue; Designing System																
8	Submission of Interim Report Final Draft																
9	Oral Presentation																

Suggested milestone
 Process