

**Harnessing Wave Energy for Generating Electricity**

**By**

**Ahmad Yusof Bin Razak**

**Dissertation submitted in partial fulfilment of**

**the requirements for the**

**Bachelor of Engineering (Hons)**

**(Electrical and Electronic Engineering)**

**May 2011**

**Universiti Teknologi PETRONAS**

**Bandar Seri Iskandar**

**31750 Tronoh**

**Perak Darul Ridzuan**

**CERTIFICATION OF APPROVAL**

**Harnessing Wave Energy for Generating Electricity**

by

**Ahmad Yusof Bin Razak**

A project dissertation submitted to the  
Electrical and Electronics Engineering Programme  
Universiti Teknologi PETRONAS  
in partial fulfilment of the requirement for the  
BACHELOR OF ENGINEERING (Hons)  
(ELECTRICAL AND ELECTRONICS ENGINEERING)

Approved by,



(Dr. Nursyarizal Bin Mohd Nor)

Project Supervisor

UNIVERSITI TEKNOLOGI PETRONAS

TRONOH, PERAK

May 2011

## **CERTIFICATION OF ORIGINALITY**

This is to certify that I am responsible for the work submitted in this project, that the original work is my own except as specified in the references and acknowledgements, and that the original work contained herein have not been undertaken or done by unspecified sources or persons.

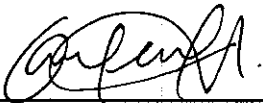

---

**AHMAD YUSOF BIN RAZAK**

## **ABSTRACT**

Nowadays, Renewable Energy (RE) has a significant role in providing a safe, reliable and cheap alternative for all of our energy needs. This role will keep growing as a result of increasing global energy demands, climate change warning and depletion of the fossil fuel resources due to the vast usage of the sources to get energy call electrical energy. Unfortunately, which is mostly the concentration of carbon dioxide (CO<sub>2</sub>) is increasing constantly and also the effect of global warming is becoming ever more evident. Hence, the global implementation of Renewable Energy (RE) technology can contribute significantly to this problem. This project entitled Harnessing Marine Energy for Generating Electricity will discuss about a design suitable for energy extraction/conversion by utilizing both wave and tides energy. The prototype was developed as an example of wave energy generator by using a direct drive concept in a number of specific ways. The energy converter is the main part of this prototype that will be thoroughly described in the chapters to come. The basic principle used is linear motion that can directly produce electricity. The outcomes of the project prove that the concept of linear motion applied in energy conversion can produce certain amount of electrical energy.

## **ACKNOWLEDGEMENTS**

All praised to Allah the Almighty, who has helped and gave me the courage and strength to complete the project dissertation of Final Year Project. With His Grace and Mercy, this endeavour is now a success.

First and foremost, I would like to address my highest gratitude to my parent, Mdm. Waginah binti Kusni for her motivations, advices, inspiration and pray for my success in completing the project even though the obstacles were always coming from every direction.

I would like to pay my gratitude to my supervisor, Dr. Nursyarizal Bin Mohd Nor and my co-supervisor, Associate Professor Dr. Balbir Singh Mahinder Singh, who had guided and given me this once in a lifetime opportunity to handle this project. Compliments also goes to all Electrical and Electronics Engineering lecturers and technicians for being ever helpful in providing assistance and giving constructive criticism to help improve the project.

I am profoundly grateful to Ms. Siti Hawa and Final Year Project (FYP) Committee. Their endurance in advising me and everyone else on the right procedure of reports were irreplaceable.

Finally, I would like to dedicate this project to my friends for giving their tireless support and continuous motivation throughout a year in completing this project.

## **TABLE OF CONTENTS**

<b>CERTIFICATION OF APPROVAL</b>	i
<b>CERTIFICATION OF ORIGINALITY</b>	ii
<b>ABSTRACT</b>	iii
<b>ACKNOWLEDGEMENT.</b>	iv
<b>LIST OF FIGURES</b>	vii
<b>LIST OF ABBREVIATIONS.</b>	ix
<b>CHAPTER 1:INTRODUCTION</b>	1
1.1 Background of Study	1
1.2 Problem Statement	4
1.3 Objectives	7
1.4 Scope of Study	7
1.5 Relevancy of the project	8
<b>CHAPTER 2:LITERATURE REVIEW</b>	9
2.1 Energy and Power from the waves	9
2.2 Energy and Power from the Tides	9
2.3 Energy and Power from ocean thermal	10
2.4 Offshore wind energy	10
2.5 Wave energy extraction technologies.	11

2.5.1 Shoreline devices	11
2.5.2 Nearshore devices	12
2.5.3 Offshore devices	13
2.5.4 Comparison of different technology	13
2.6 Buoy system	14
2.6.1 Float type	14
2.6.2 Tube type	15
2.7 Faraday's Law.	16
2.8 Bridge Rectifier Circuit	17
<b>CHAPTER 3: METHODOLOGY</b>	<b>19</b>
3.1 Research Methodology.	19
3.2 Wave energy converter concept	20
3.3 Project Activity	21
3.4 Key Milestone.	25
<b>CHAPTER 4: Results and Discussions</b>	<b>26</b>
4.1 Results and Discussion.	26
<b>CHAPTER 5: Conclusions and Recommendations.</b>	<b>31</b>
<b>REFERENCES</b>	<b>33</b>
<b>APPENDICES.</b>	<b>33</b>

## **LIST OF FIGURES**

Figure 1: Ocean Energy Categories . . . . .	2
Figure 2: Wave Energy Propagation . . . . .	3
Figure 3: Wave Energy Form . . . . .	3
Figure 4: Wave energy conversion steps . . . . .	6
Figure 5: Working Principle of OWC. . . . .	12
Figure 6: Below surface point absorber . . . . .	15
Figure 7: Half-wave bridge rectifier . . . . .	17
Figure 8: Full-wave bridge rectifier . . . . .	18
Figure 9: Project Activities Flow Chart . . . . .	19
Figure 10: Energy Storage Circuit . . . . .	22
Figure 11: Ultra capacitor . . . . .	22
Figure 12: Energy Storage Circuit . . . . .	23
Figure 13: Permanent Magnet. . . . .	23
Figure 14: Energy Generator with coil . . . . .	23
Figure 15: Buoy . . . . .	24
Figure 16: Schematic of the prototype . . . . .	24
Figure 17: 750 User interface – Pasco . . . . .	25
Figure 18: Captured of prototype model . . . . .	26



Figure 19: Output voltage versus Time	.	.	.	.	.	27
Figure 20: Output current versus Time	.	.	.	.	.	28
Figure 21: Charging Ultra capacitor versus Time	.	.	.	.	.	29
Figure 22: Charging battery versus Time.	.	.	.	.	.	30

## **LIST OF ABBREVIATIONS**

<b>RE</b>	<b>Renewable Energy</b>
<b>SREP</b>	<b>Small Renewable Energy Program</b>
<b>OTEC</b>	<b>Ocean Thermal Energy Conversion</b>
<b>OWC</b>	<b>Ocean Water Column</b>
<b>OSPRED</b>	<b>Ocean Small Powered Renewable Energy</b>
<b>WEC</b>	<b>Wave Energy Converter</b>
<b>EMF</b>	<b>Electromotive Force</b>
<b>LED</b>	<b>Light Emitting Diode</b>
<b>NdFeB</b>	<b>Neodymium Iron Boron</b>

# **CHAPTER 1**

## **INTRODUCTION**

### **1.1 Background of study**

Energy that comes from natural resources such as sunlight, wind, rain, marines, and geothermal heat is called Renewable Energy (RE) and these energy are naturally replenished. Marine energy source has a large potential that may contribute to the worldwide increasing demand. The large potential of marines energies make technologies for harnessing this energy to be investigated and developed.

In line with the objectives of the Third Outline Perspective Plan (OPP3) (2001-2010) and Eighth Malaysia Plan (2001-2005) to promote and increase the use of renewable energy (RE), the Government had formulated several strategies to strengthen and develop the use of RE as the fifth country's energy resources. Moreover, the implementation of the Ninth Malaysia Plan (RMK-9), such that, the Government has set a target of generating electricity in grid connected using RE sources such as biomass, biogas, mini-hydro, wind, solar and municipal waste for total of 350MW which come from peninsular Malaysia (300MW) and Sabah (50MW) [1].

Furthermore, the Government is very committed to ensure the success of RE development in Malaysia especially through the implementation of Small Renewable Energy Program (SREP) which was introduced in 2001. Government had put a lot of effort in order to encourage developers of RE projects to participate actively in this

sector. Some of the efforts were the establishment of infrastructure for RE development, developing programs for RE industry & market and providing more conducive environment [1].

The solutions to today's energy challenges need to be found through increased electricity generation using alternative, renewable and clean energy sources. An extremely promising source of energy exists in the world's oceans. It is estimated that if 0.2% of the ocean's untapped energy could be harnessed, it could provide power sufficient for the entire world [2].

There are five categories of extraction for ocean energy that generates different ranges of electricity as shown in Figure 1.

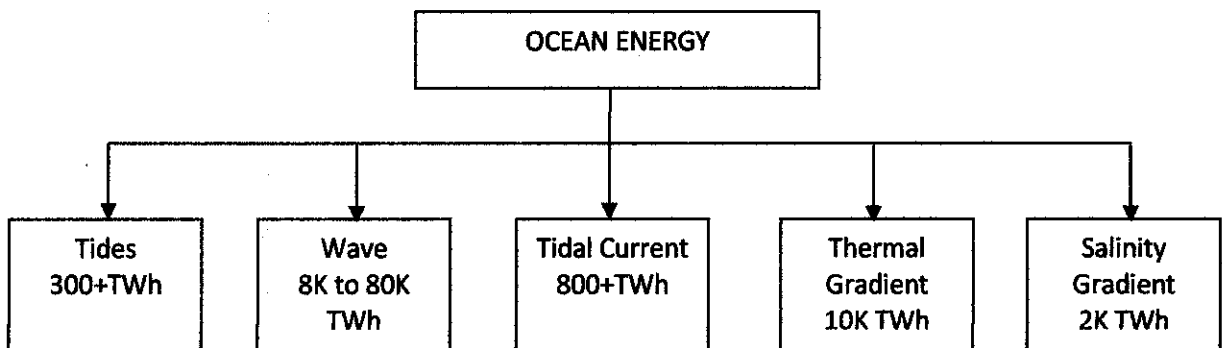

Figure 1: Ocean Energy Categories

This report will be focusing on the wave energy extraction method because the extraction of this energy comes from the rise and fall of tidal and waves. A vast store of kinetic energy is created by the movement of water in the world's ocean. Therefore, the oscillation motion of incoming and outgoing waves can be utilize to generate electricity. The process to exploit the large potential of this energy is still in development.

Wind generated waves have the highest energy concentration and this energy transfer provides a natural storage of wind energy in the water near the surface [2]. Wind waves can travel thousand kilometers with only small portion of energy losses, but the intensity of the energy decrease nearer the coastline due to the interaction with seabed. Figure 2 shows the wave energy propagation generated by wind.

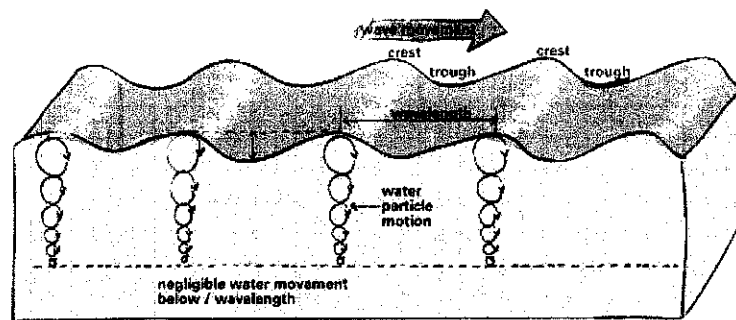

Figure 2: Wave Energy Propagation

Basically, there are two forms of energy in ocean waves which are kinetics and potential energy as illustrated in Figure 3. The energy that follows the circular path of water particle is kinetics energy. Meanwhile the potential energy is the elevated water particles. The increase of wind speed and duration result in increasing of wave height since wave started to blow [2]. Wave energy power can be determined by wave height, wave speed, wavelength, and water density. A device is needed which can convert this raw energy to generate electricity. Depending on the distance between the conversion devices and the shoreline, wave energy systems can be classified as shoreline, nearshore and offshore extraction systems.

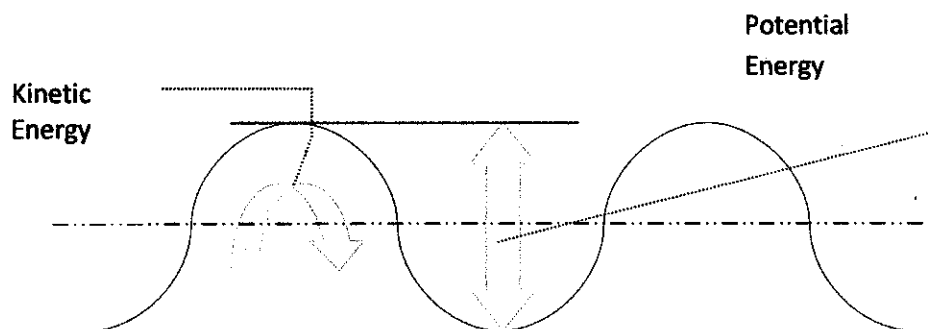

Figure 3: Wave Energy Form

## 1.2 Problem Statement

The effect of global warming that mostly attributes by the rise of the world energy consumption worries people especially scientist and engineers. Generally, the continuous dependency on fossil fuel sources will only exacerbate this situation. The study has been done where stated that, if we continuously consume the fossil fuel which is non-renewable energy at current rate where it is increase year by year, some of these energy sources will be exhausted within a century or may last for less than few decades [3].

Problem associated with fossil fuel or non-renewable energy has been subject of numerous reports, including increases environmental depletion. Moreover, in term of energy security, non-renewable energy is uneconomical. This is due to the cost of energy resources that is unpredictable. Considerably more energy needed, much of high grade energy resources are required to produce more energy output.

Clear and sustainable energy is becoming popular amongst respective industries as oil costs rise (fossil fuel) and the negative effect of traditional energy system that lead to global warming hence, the search of renewable energy sources becomes more significant. When talking about renewable energies, wind, hydro and solar energy typically come to mind. Actually, there is one major resource that has remained untapped until now: marine energy. Its potential has been recognized for long and there are a number of approaches to harness marine energy, though most remain in the investigation or demonstration phase.

Marine renewable energy is referring to the energy carried by ocean waves and tides. Moreover, the energy in motion or vast store of kinetic energy is created by the movement of water in the world's oceans. Electricity can be created by harnessing this energy and can be used to power homes, transport and industries. Basically, the term marine energy covers both wave energy and tidal energy obtained

from large bodies of water such as oceans and seas. Furthermore, several researches show that ocean energy has the potentiality of providing for a substantial amount of new renewable energy around the world. [4]

The first real attempts to construct wave energy converters were made in the 1970s, when the oil crisis caused a sudden interest in finding complementary sources of energy. The scientists were virtually starting from scratch, and they took years to build a knowledge base and to gain experiences [5, 6]. As usual, new technologies tend to have problems such that machines made to absorb the power of the waves tend to break. When a machine can be built which can withstand the forces, it tends to be way too costly. Many doubted that it would ever be possible to extract the wave energy in an economic way and, as oil prices sank, the funding for wave energy research was discontinued [7].

There are many obstacles faced by engineers and scientist in order to construct a technology that is adapted to the constraints given by the natural resource and also to fulfill the basic and grid connection demands of profitability and environmental friendliness. Generally, there are 4 main issues highlighted here; survivability, reduced power absorption at higher wave conditions, robustness and system approach [7]:

- i. **Survivability** — the exposure of wave energy plant to enormous forces and often there are small possibilities of turning off a wave energy plant. Therefore, many of the first full scale trials have simply collapsed during storms. This results in a great extent to an economical problem. In order to withstand the forces encountered in a 100-year storm, the plant needs to be dimensioned, but will have to be economically viable for much lower average powers [7].
- ii. **Reduced power absorption at higher wave conditions** — The ability to reduce the power absorption in larger waves is one of the crucial questions in wave

energy engineering identified. The important of this is not only it limits the maximum mechanical strains but also the maximum electrical loading. Actually, this has impacts on both survivability and on the utility factor [7].

- iii. Robustness — A wave energy plant needs to be employed for several years to be economically viable and also require a minimum of maintenance. More important thing for offshore concept is low maintenance needed since access will be difficult and expensive [7].
- iv. System approach — There are 4 major steps for the conversion of wave energy into electricity; absorption, conversion, transmission, and grid connection, schematically illustrated in Figure 4. The interesting parameter is the performance of the whole system but not the isolated performance of one single component. Thus, it is very important to have an overview and an understanding of the interaction between the different components in the system [7].

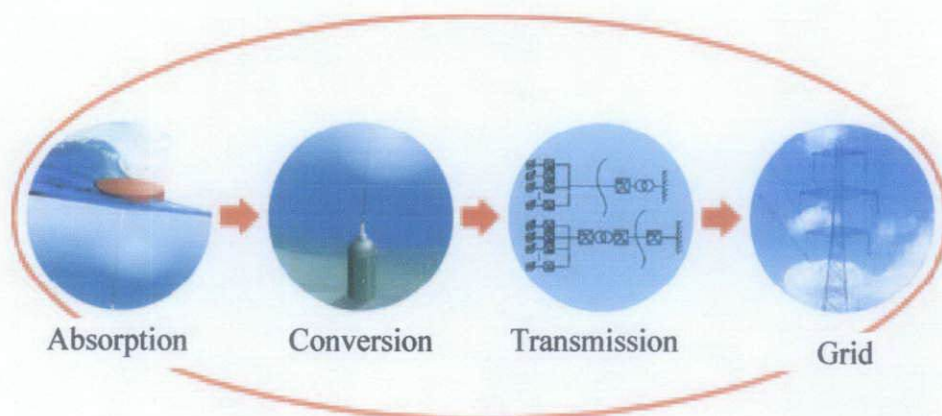

Figure 4: Wave energy conversion steps [7]

In order to harness wave energy, a device to captures energy from a wave and converts mechanical wave energy into electrical energy is needed. Basic concept of this device is by capturing the vertical motion of a wave and converting into electrical energy that can either be stored or immediately be used. There are a lot of designs and types made by former engineers and scientist. In this report, some of the design and models will be discussed and compared.



### **1.3 Objectives**

The main objectives of this project are:

- Research on renewable energy and marine energy.
- To analyze suitable energy conversion system
- To design, fabricate and implement a prototype of energy conversion system.
- To observe the performance of the prototype.

### **1.4 Scope of study**

The scope of study for this project is to produce working prototype by manipulating marine energy. Generally, a simple type of energy conversion is always permanent magnet linear generator types. The design has only two components such that, permanent magnet and stator which is N turns of coils.

The summary of scope of study is summarized below:

1. Choose type of magnet  
Neodymium magnet also known as rare earth magnet was chosen in this project because of its strength property.
2. Energy conversion prototype design  
The design is focus on Lab scale prototype because the time constraint and easy to implement.
3. Results  
Observe the performance of the prototype such that the current and voltage.

### **1.5 Relevancy of the project**

Generally, this project is relevant to student who's taking electrical & electronics engineering because it incorporates knowledge in electrical machines, power system, circuit theory and numerical methods. In addition, it also enhances project management and communication skills. Overall, the feasibility of plan is according to the factors as shown below:

- **Time:** 2 semesters to complete the project
- **Cost:** Given RM500 to complete this project.
- **Material:** Research on the material used with suitable properties and contact the material supplier.

## **CHAPTER 2**

### **LITERATURE REVIEW**

#### **2.1 Energy and Power from the waves**

Energy from the waves can be captured directly from surface waves or from pressure fluctuations below the surface. Moreover, wave energy is a concentrated form of solar energy: the sun produces temperature differences across the globe, causing winds that blow over the ocean surface [8]. These cause ripples, which grow into swells. Such waves can then travel thousands of miles with virtually no loss of energy [8].

Wave power can varies significantly in different parts of the world, and basically, wave energy can't be harnessed effectively everywhere. For example, the rich areas of wave-power in the world include the western coasts of Scotland, northern Canada, southern Africa, Australia, and the northwestern coasts of the United States.

#### **2.2 Energy and Power from the tides**

The ocean tide is produced primarily by fluctuations in the resultant of the several forces of gravity and of centrifugal action caused by Earth's rotation and by changes in relative positions of earth, the moon and the sun [9]. Therefore, the tide is cause by the force substantially the resultant of attractive forces due to the moon and sun and centrifugal force caused by rotation of Earth-moon system.

Basically, tidal energy is a renewable energy resource and cleans but its environmental impacts and accessibility limit its potential to become a major provider of electricity. Moreover, tidal energy is a viable resource, although it may prove to be expensive at first but economical in the long run if the technology improves.

### **2.3 Energy and Power from ocean thermal**

Another energy that can be harnessed from ocean is called Ocean Thermal Energy Conversion (OTEC). This energy converts solar radiation to electric power which use natural thermal gradient of the ocean to drive a power-producing cycle. The concept stated, as long as the different between warm surface temperature and the cold deep water is about 20°C (36°F), a significant amount of power can be produced by OTEC system [9].

OTEC has high potential as renewable resource to help people produce vast of electric power. This is because the oceans cover more than 70% of Earth's surface that makes them the world's largest solar energy collector and energy storage system. Furthermore, one of the advantages of OTEC is, the cold, deep seawater used in the process is rich in nutrients and it can be used to culture both marine organisms and plant life near the shore or on land.

### **2.4 Offshore wind energy**

Currently, in shallow waters off the coasts of Europe, commercial-scale offshore wind facilities are in operation. Offshore wind energy converts wind motion into electric energy. Basically, the earth's surface is made of various water and land formations, hence sun absorption occur unevenly. This uneven heating of the earth's surface by the sun produce wind. Offshore wind turbines are being used to harness this particular energy of the moving air over the oceans to convert it into electricity. Research being done to compare between onshore and offshore winds and the results

appear that offshore winds tend to flow at higher speeds, thus can allow turbines to produce more electricity. The potential energy produced by the wind is directly proportional to the wind speed. If the change in speeds increases of only 2 or 3 miles per hour, the results can generate a significantly larger amount of electricity.

## **2.5 Wave energy extraction technologies**

As mention earlier, depending on the distance between the conversion devices and the shoreline, wave energy systems can be classified as shoreline, nearshore and offshore extraction systems.

### *2.5.1 Shoreline devices*

These devices are embedded in the shoreline and one of the examples for this device is Oscillating Water Column (OWC). This is the most developed of the shoreline devices. Basically, an OWC system has a partially submerged hollow air chamber, which opens to the sea under the water line. When a wave enters the air chamber, there will be a force to push the air in the column to pass through a turbine, and when the wave retreats, this air will be drawn back and pass through the turbine again as shown in figure 5. The world's first commercial wave power unit is the LIMPET 500, an OWC system mounted on the cliffs of the Islay island in Scotland by Wavegen. This system can generates a peak power of 500 kW that can provide service for about 400 island homes. Moreover, this system has successfully fed electricity into the UK's national grid since November 2000 [8].

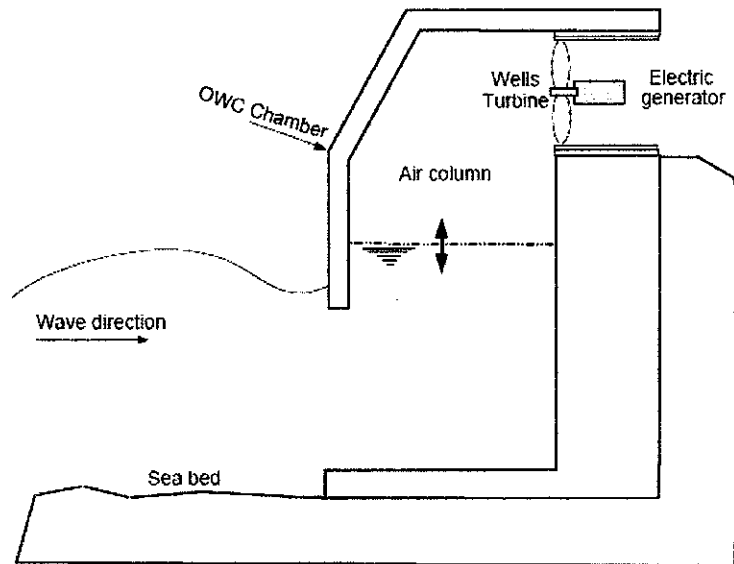

Figure 5: Working Principle of OWC [2]

### 2.5.2 Nearshore devices

These devices are in between the shoreline devices and offshore devices. Moreover, these devices are characterized by being used to extract the power directly from the breaker zone and the waters immediately beyond the breaker zone. Through the year, several approaches have been proposed. The ocean swell powered renewable energy (OSPREY) is designed to operate in 15 m of water within 1 km of the shore, generating up to 2 MW of power for coastal consumers [10]. The Mighty Whale is a floating OWC based device developed by JAMSTEC. A 120 kW prototype with three OWC's in a row has been operating since 1998 in water depths of 40 m, 1.5 km off Nansei Town in Japan [2]. An example of a nearshore device is the Pelamis developed by Ocean Power Delivery in Edinburgh, Scotland [11]. Basically, this is a semi-submerged, articulated structure composed of cylindrical sections linked by hinged joints. The sections of the Pelamis act as a pump and move hydraulic fluid through hydro-turbine generators as the waves peak and trough. Besides, the power generated from each segment runs to an underwater substation

and then to land via a submersible electric cable. Moreover, a 750 kW prototype of the OPD Pelamis was tested in August 2004 off the coast of Orkney, Scotland [2].

### *2.5.3 Offshore devices*

An example of offshore devices is buoy generator which utilize the high energy densities and higher power wave profiles available in the deep-water waves and surges. The basic concept to extract the maximum amount of energy from the waves, the devices needs to be at or near the surface hence this makes it a requirement to have flexible moorings. Besides, submersible electrical cables are needed for utility grid support applications to transmit the generated power onto land where they can be interconnected to the grid [2]. One of the example offshore buoy system is The AquaBuoy [12]. This technology is now being promoted by the AquaEnergy Group of Mercer Island, Washington and was originally patented in Sweden. Basically, the up and down motions of ocean waves cause pressure changes which draws seawater into a hose pump. Then, the pressurized water is expelled into a collecting line which leading to a turbine to generates electricity. The individual sizes of the buoys are designed according to the energy content of the prevailing seas at a particular installation site. The capacity of the plant is scalable by using different numbers of buoys [12].

### *2.5.4 Comparisons of different technology*

One of the advantages of Shoreline devices is easier access for installation and maintenance and they do not need deep-water moorings or long underwater electrical cables. Nevertheless, the disadvantages of these devices is when a wave travels towards the shoreline, its power is greatly reduced by the friction caused by the rough seabed. Hence, this can be partially compensated by sitting the devices at locations of natural energy concentration [2].

The advantage of offshore devices is it is the more powerful wave profiles available in deeper water. But, they usually require flexible moorings and submarine electrical cables for power transmission in order to extract the maximum amount of energy from the waves and the devices need to be at or near the surface. Therefore these features cause critical cost issues in construction and maintenance [2].

In general nearshore devices exhibit compromises between shoreline and offshore devices, for example, when there are environmental objections to shoreline devices, near shore devices can provide an alternative solution [2].

## **2.6 Buoy System**

Generally, the buoy type wave energy converter is also known as a “point absorber”. It is due to harvests energy from all directions at one point in the ocean. Usually, these devices are placed at or near the ocean surface away from the shoreline. There are several types of point absorbers but the common being the hollow tube type and the float type, although there are other forms.

### *2.6.1 Float type*

Basically, the float on this point absorber bobs up and down with the change in mass above it. The water mass increases above the float as a wave crest approaches, thus pushing it down. In mathematics, the forces acting on the float may be modeled via Newton’s equation,  $F=ma$  [13]. The float type in Figure 6 operates with several different power take-off methods. Basically, the floater will move in different directions relative to wave motion depending on its location above or below the water. If the floater is on the surface, it will move up and down with the wave. Hence, this poses control problems because the wave height may exceed the WEC’s stroke length. Usually, the worst possible outcome could be damage to the WEC during a storm when wave heights are extreme. Therefore, the solution to this problem of limited stroke length is to place the tube under water [13].



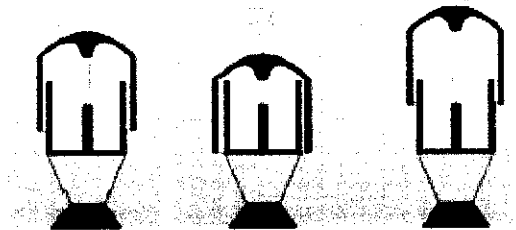

Figure 6: Below surface point absorber [2]

Figure 5 illustrates the motion of a below surface point absorber relative to wave motion. When a wave crest passes overhead, the extra water mass pushes the float down, and when a wave trough passes, the absence of water mass pulls the float up since it becomes lighter than the water overhead. A control system can pump water and/or air into the float to vary buoyancy and thus restrain the float if large wave heights are experienced. Moreover, if a rough storm occurs, the entire system will be underwater and out of harm's way. As with the tube type point absorber, the up and down motion of the floater relative to some stationary foundation will act on a piston. This piston can be connected to a generator using any of the methods described earlier. With a float instead of a tube, other conversion mechanisms may be utilized [13].

### 2.6.2 Tube type

If this type is going to be compared with float type point absorber equations, can be more complicated. It is calculated using Bernoulli's theory for unsteady flow. But, an easier method of evaluating the power for the tube type point absorber is found by calculating the force on the piston within the tube based on how much power is to be developed and how long the piston stroke [13]. This type of energy

converter consists of a vertically submerged, neutrally buoyant (relative to its position just below the mean ocean surface level) hollow tube. This tube allows water to pass through it, driving either a piston or a hydro turbine. For this application, the piston power take-off method is better suited because the rate of water flowing through the tube is not rapid [13].

Generally, there are two tube arrangements; one end may be closed and the other open or both open. As for the both ends closed, no water flows and the device becomes the float type. A pressure difference between top and bottom of the long, cylindrical tube were experiences, causing water to flow into and out of the open end(s) of the tube. This is like, when a wave crest passes above a tube, water will flow down the tube, and when a wave trough passes above the tube, water will flow up the tube. Piston will be pushed which may either power a drive belt, a hydraulic system, or a linear generator [13].

**2.7 Faraday’s Law**

The basic law of electromagnetism relating to the operating principles of transformer, inductors and other electromotor and generator is Faraday’s Law. The law states that: The induced electromotive force (EMF) in any closed circuit is equal to the time rate of change of the magnetic flux through the circuit. Or alternatively: The EMF generated is proportional to the rate of change of the magnetic flux [15]. The faraday’s law related to the formula below:

$$V_{gen} = -N \frac{\Delta(BA)}{\Delta t} \dots\dots\dots (1)$$

Where;

N = number of coil turns

$V_{gen}$  = Voltage induces

$\frac{\Delta(BA)}{\Delta t}$  = change of flux

Basically, faraday's law is a fundamental relationship that comes from a very popular equation, Maxwell's equations. By a changing magnetic environment, it serves as a concise summary of the ways a voltage (or EMF) may be generated [15]. The induced EMF in a coil,  $V_{gen}$  is equal to the negative of the rate of change of magnetic flux,  $\frac{\Delta(BA)}{\Delta t}$  times the number of turns in the coil, N. It involves the dealings of charge with magnetic field.

The negative sign in the equations is comes from Lenz's law which state that the polarity of the induced EMF is such that it produces a current whose magnetic field opposes the change which produces it when an EMF is generated by a change in magnetic flux according to Faraday's Law [15].

## 2.8 Bridge Rectifier Circuit [16]

The most popular application of the diode is rectification. Rectification is the conversion of alternating current (AC) to direct current (DC) which involves a device that only allows one-way flow of electrons. As one can see, the function or operating principle of semiconductor diode is very useful for this purpose because this is exactly what it does. Basically, the simplest kind of rectifier circuit is the half-wave rectifier as shown in Figure 7.

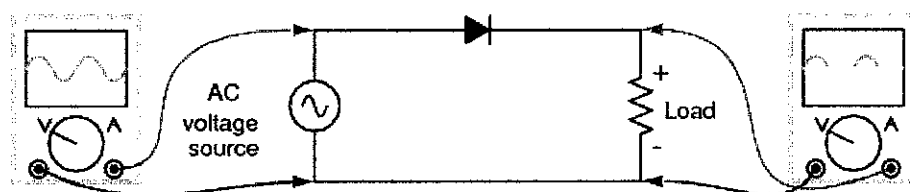

Figure 7: Half-wave rectifier [16]

It only allows one half of an AC waveform to pass through to the load. Half-wave rectification is insufficient for most power applications. This is because harmonic content of the rectifier's output waveform is very large and consequently

difficult to filter. Moreover, the AC power source only supplies power to the load one half every full cycle leaves half of its capacity unused. However, half-wave rectification also has its own purpose such as it is a very simple way to reduce power to a resistive load.

In order to obtain the full use of half-cycles of the AC-source, a different rectifier circuit configuration must be used. This circuit called a full-wave rectifier and most popular full-wave rectifier design is built around a four-diode bridge configuration as shown in Figure 8.

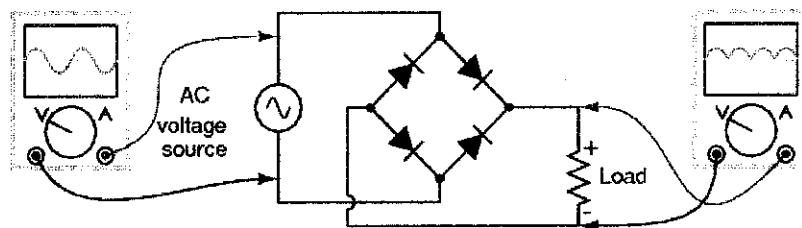

Figure 8: Full wave bridge rectifier[16]

Compared to half-wave rectifier, it allows both half of an AC waveform to pass through to the load. Thus, it can give full potential of output based on its input. Generally, a full-wave rectifier converts the whole of the input waveform to one of constant polarity which is positive or negative at its output. It is more efficient compared to half-wave rectifier because it converts both polarities of the input waveform to DC (direct current).

## CHAPTER 3

### METHODOLOGY

#### 3.1 Research Methodology

The project activities flow is shown in Figure 9.

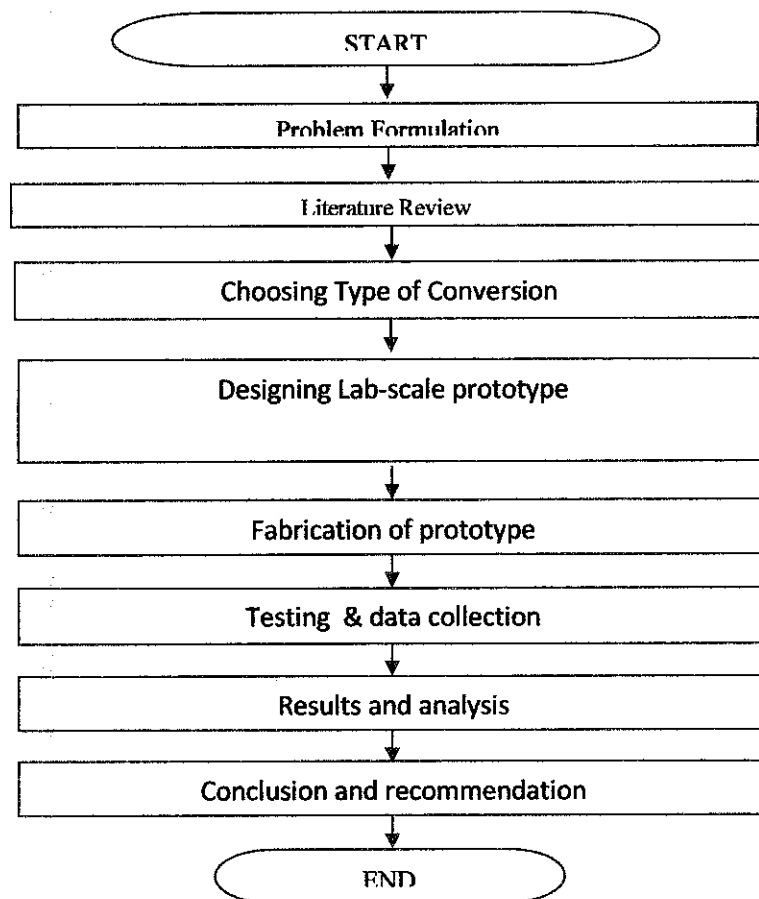

Figure 9: Project Activities Flow Chart

### **3.2 The Wave Energy Converter Concept**

The prototype was developed as an example of wave energy generator. The concept of this prototype is using a direct drive concept in a number of specific ways. For example, buoyant moored device floats on the surface of the water and moored to the seabed and the power absorption is carried out by this floating buoy which is often referred to as a point absorber.

The buoy is coupled directly with the moving part such as the permanent magnet of an energy generator, which is placed on the sea bed. Basically, the energy generator is the main part of this prototype that will be thoroughly described in the chapters to come. The tension in the rope and the restoring force are provided by a set of springs, which pulls the permanent magnet downwards. Then, the wave crests will pull the buoy and permanent magnet upwards and the springs and mass of the system will drag the permanent magnet and buoy downwards in the wave troughs. The stroke length of the permanent magnet is limited by end stops at the top and bottom of the generator that stop the permanent magnet as it reaches the ends. Hence, in order to generate power, a wave power machine needs to resist the motion of the waves in order to generate power such that, part of the machine needs to move while the other part remains still.

In general, permanent magnets that moving up and down cutting the coils with its magnetic field, will induce a voltage. This will drive a current in the cable windings in the coil. Since the permanent magnet speed is varying, both the frequency and amplitude of the induced currents will vary and cannot be directly connected to a load or in real life scenario is AC-grid. Therefore, the current of a generator is rectified and will produce a DC-current output.

Basically, the primary components for this prototype are coils and magnets. By applying Faraday's law which state that, when a conductor such as coil,

experiences a changing magnetic field, voltage is induced in the conductor/coil. In this case, the linear motion of the permanent magnet which goes up and down repeatedly across the coil will generate electricity. In fact, the coil experiences a changing magnetic field, since the conductor is a coil in a closed circuit, current flows and can lights up an LED (light emitting diode).

#### *3.4.1 Primary Components:*

The prototype of wave energy can include:

1. Buoy
2. Permanent Magnet
3. Coil
4. Storage system

The portion of the wave energy generator that moves up and down on the surface of the ocean is the buoy. In this prototype, electricity is generated due to the relative motion of the buoy which moves permanent magnet up and down relative to the coil assembly on the stationary shaft. For this particular prototype, direct drive concept is used which is up-down motion by applying electromagnetic induction concept.

### **3.3 Project Activities**

#### *3.3.1 An Energy Storage System*

At first, the prototype consists of coil, magnet and LED. When it is operated, the only thing that can be seen is the LED flicker. This is because, when a magnet passes through a coil, it only produce an amount of current at that time and if it is not stored it will just waste like that. Hence this flickering can be reduced which will

result in more continuous lighting of the LED by using energy storage component such as ultra capacitor.

Energy storage system consists of ultra capacitor and a diode rectifier bridge which function to convert ac voltage to dc voltage. It is illustrated in Figure 10.

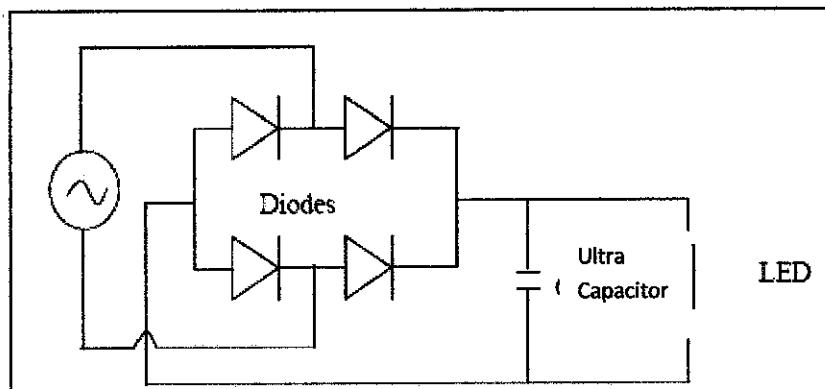

Figure 10: Energy Storage Circuit

The Components needed for energy storage circuit are as follow:

1. Diode (Low voltage) – Figure 12
2. Capacitor (1 Farad) – Figure 11
3. Vero board
4. Super bright LED (Light Emitting Diode) – Figure 12
5. Wires - 18"

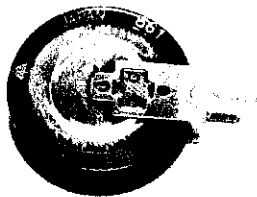

Figure 11: Ultra capacitor for storing energy





Figure12: Energy storage circuit



Figure 13: Permanent magnet

Figure 13 is permanent magnet and act as rotor which functions in this case is to move up and down carrying magnetic field and cut the coils to produce current.

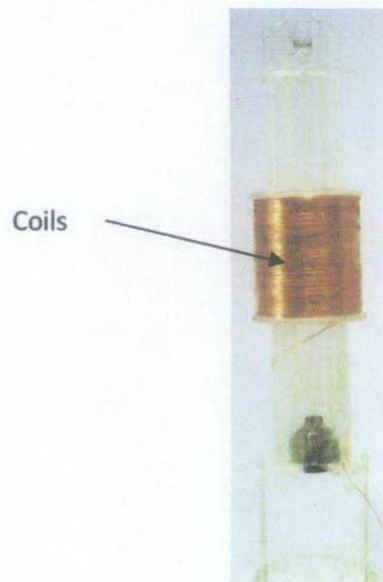

Figure 14: Linear motion generator

Figure 14 shows the energy generator with coil and act as stator for this prototype.



Figure 15: Buoy

Figure 15 shows the type of buoy that is being used to make sure the permanent magnet moving up and down as the concept mention earlier.

### 3.3.2 Experimental Method

The experiment comprised of a small lab-scaled prototype which consists of permanent magnet, coils, small aquarium and buoy. Figure 16 shows the prototype arrangement.

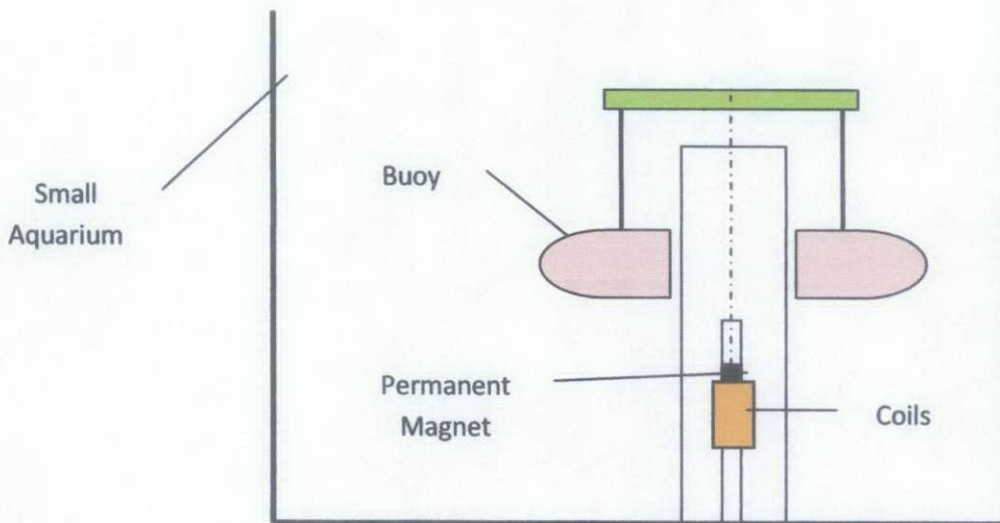

Figure 16: Schematic of the prototype

The small aquarium was built by using acrylic plastic with 8mm and 10mm thick to make sure it can withstand the water pressure. Then, the buoy was made by using Styrofoam because its property of buoyancy. As for the coils, enamelled wire

or also known as magnet wire is used and rare earth magnet, Neodymium Iron Boron (NdFeB or NIB) is used as moving part for linear generator.

After finishes fabricate the prototype, it will need to be analyzed. One of the devices that can be used to observe the current/voltage behaviour is Science Workshop 750 user interface (Pasco) as shown in Figure 17.



Figure 17: 750 user interface (Pasco)

### 3.4 Key Milestone

Below shown the step by step key milestone to complete the project:

- 1 Understanding the topic
- 2 Research and analysis
- 3 Designing the prototype
- 4 Material and tool selection
- 5 Fabrication
- 6 Prototype test
- 7 Evaluate

## CHAPTER 4

### RESULTS AND DISCUSSIONS

#### 4.1 Results and Discussions



Figure 18: Captured of prototype model

Figure 18 shows the captured of prototype model. The first stage of experiment is to prove the concept of wave conversion is working. In order to prove the concept, the output from linear motion generator is connected to simple energy storage system consists of 4 diodes, a resistor and a light emitting diode. The data collection had been done by using PASCO to capture the voltage and current data behavior from the prototype.

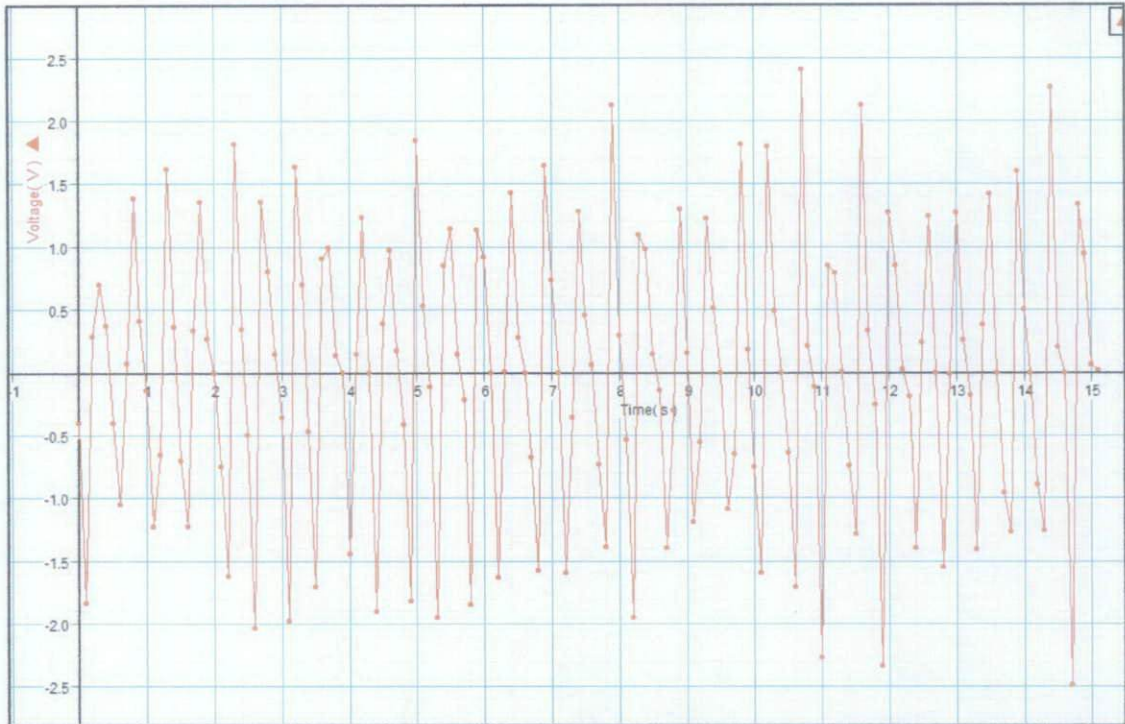

Figure 19: Output voltage versus Time

The behavior of output voltage is shown in Figure 19. The data shows triangular wave changing from negative and positive values. Basically, the output is taken directly from the output of linear motion generator. Hence, it gives the values at instantaneous time, in other words, the voltage induced at that time is not stored. The maximum voltage produced is 2.5 volts excluding the negative sign. The negative voltage produced can be explain by Lenz's law which state that the polarity of the induced EMF is such that it produces a current whose magnetic field opposes the change which produces it when an EMF is generated by a change in magnetic flux according to Faraday's Law [16]. Since the concept for generating electricity using the concept of changing magnetic field by manipulating permanent magnet and coils, the output as shown in Figure 19 is obtained. It is proven that the prototype can produce certain amount of voltage. The data can be referred in Appendix B.

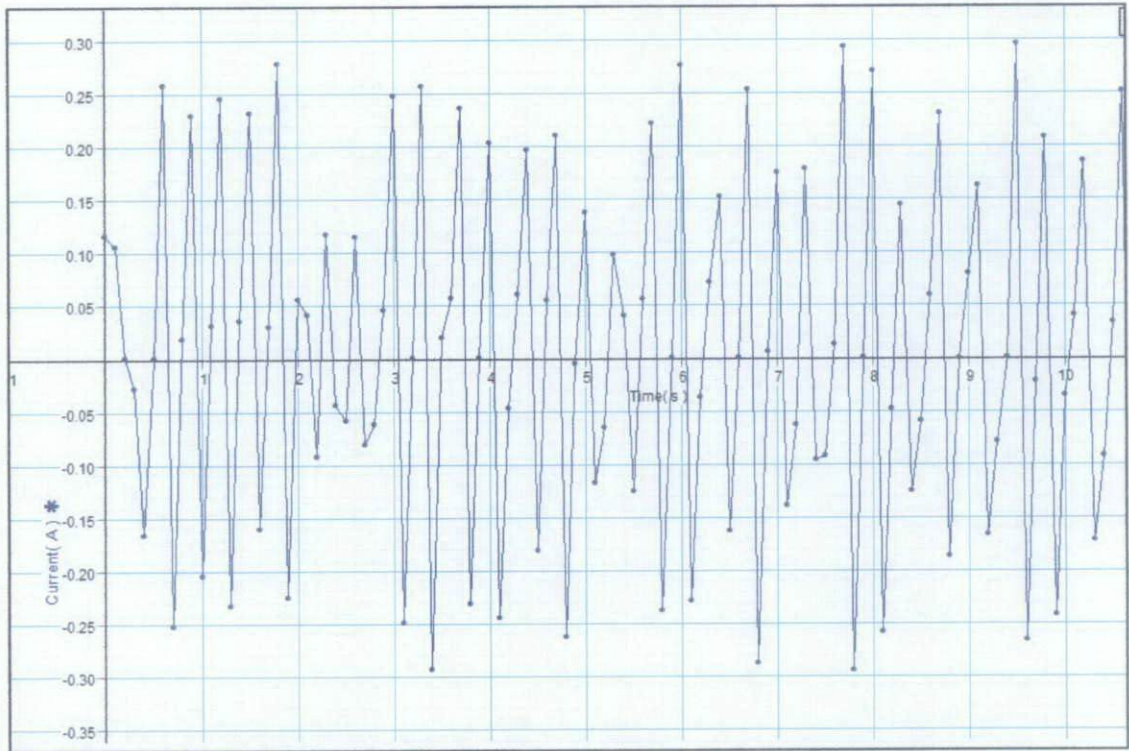

Figure 20: Output current versus Time

Next stage of data collection is to see the output current versus time. As shown in Figure 20, the output current produces is triangular wave changing from positive and negative value. As mention earlier, this is due to Lenz's law and since the permanent magnet goes up and down which produce changing magnetic flux. This changing magnetic flux then is being cut by the coils and produces certain amount of voltage and current as the wave ripple force the buoy to go up and down. The data can be referred in Appendix C.

According to Faraday's law, an EMF is generated by a change in magnetic flux and the polarity of the induced EMF is behaving like it produces a current whose magnetic field opposes the change which produces it. Hence the induced voltage or current inside the coils always acts to keep the magnetic flux in the loop constant.

The maximum current that can be produced based on output current in Figure 20 is 0.3 Ampere. To make sure the output is always positive value, another circuit is made which is energy storage circuit consists of 4 diodes and 1 storage device such as Ultra capacitor or battery that can store energy.

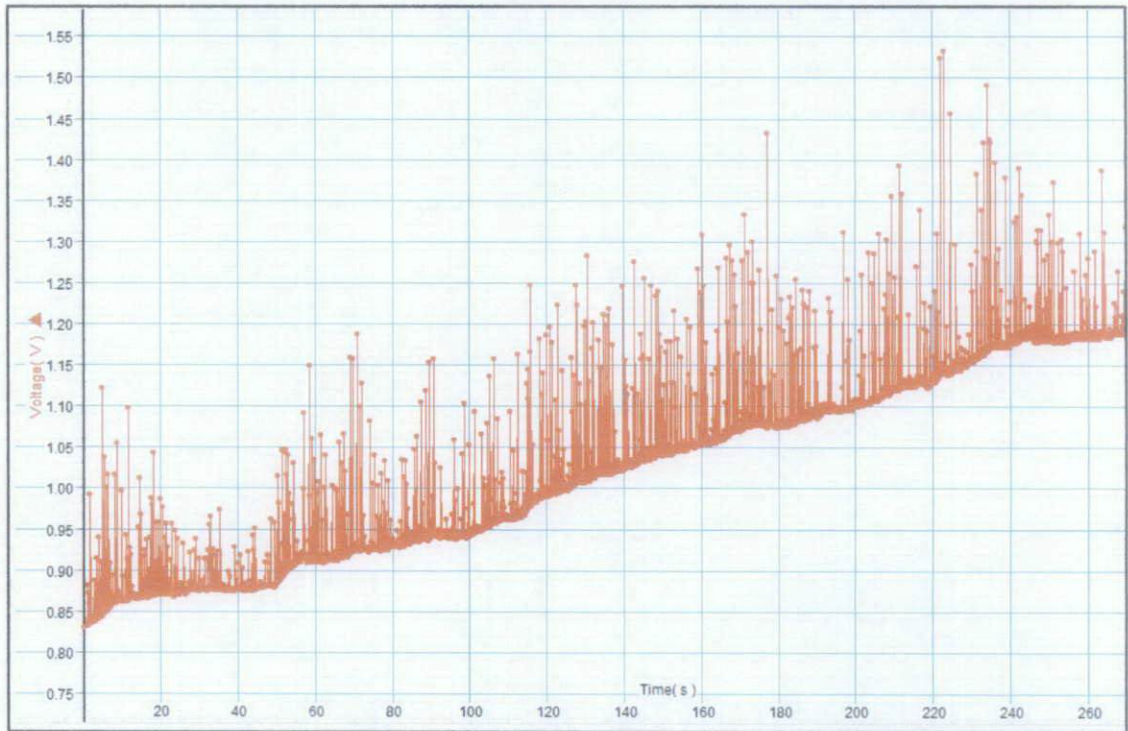

Figure 21: Charging Ultra capacitor versus Time

Figure 21 shows output voltage point which is taken from the Ultra capacitor. The data can be referred in Appendix D. The specification of ultra capacitor is as below:

- Made in: Japan,
- Voltage: 5.5V
- Capacitance: 1Farad

The ultra capacitor is chosen because it can hold the charge it store longer depends on its capacitance. The output data shows that, it keeps increasing through

time and the data almost linear. The input wave produced is keep constant and based on the data obtained I can state that wave energy conversion is successful whereby it can store energy in ultra capacitor. This system can store up to 0.37V in 270 seconds.

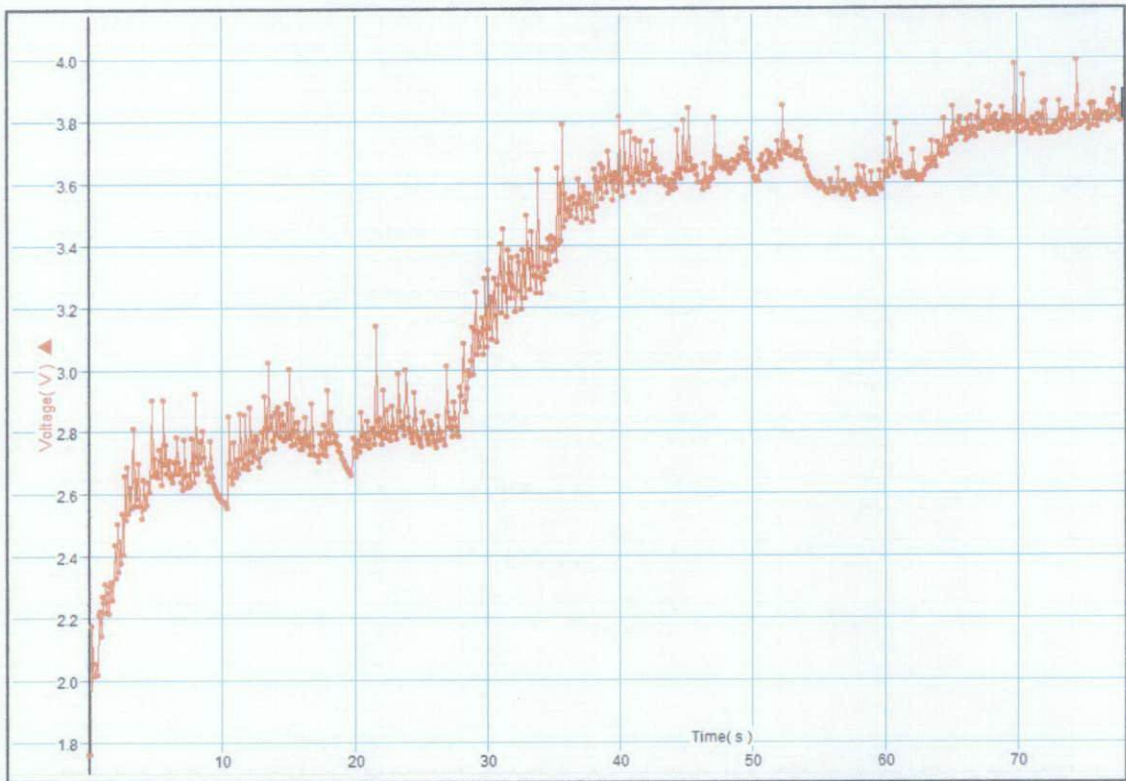

Figure 22: Charging battery versus Time

Figure 22 shows output voltage versus time and the point is taken from another storage device which is battery whose specification is 3.6V, 40mAh. The storing capability is faster compared to Ultra capacitor but, the discharge capability is faster compared to ultra capacitor. The data can be referred in Appendix E.



## **CHAPTER 5**

### **CONCLUSIONS AND RECOMMENDATIONS**

#### **5.1 Conclusions**

The prototype was developed as an example of wave energy generator. Basically, the concept used for this prototype is direct drive concept in a number of specific ways. There are two major parts in designing the prototype, one is buoyant moored device which floats on the surface of the water and moored to the seabed. The other one is the power absorption which also known as wave energy converter (WEC). The buoy is coupled directly with permanent magnet with specific rope. The tension in the rope and the restoring force are provided by a set of springs, which pulls the permanent magnet downwards. Then, the wave crests will pull the buoy and permanent magnet upwards and the springs and mass of the system will drag the permanent magnet and buoy downwards in the wave troughs. In general, permanent magnets that moving up and down cutting the coils with its magnetic field will induce a voltage, Lenz's law. Next, the rectifier circuit is used to produce a DC-current output.

Since the prototype is in a lab scale, there are three limitations with the design. First, the induced voltage is merely based on the speed of wave. In other words, more power will be induced if the speed of wave is increasing. The second limitation is when the wave height exceeds the height limit of WEC, the moving part of WEC will go out of track and it will get stuck on top of the track part. Lastly, there

is also a limitation in term of induced power due to the permanent magnet power and speed of wave which have already been explained in Chapter 4.

In addition, through one year of completing this project, there are a lot of problems occurred. One of the problems is in designing the prototype whereby it is difficult to get linear motion for the wave energy converter. Hence, the solution for this problem is to mount the WEC at the base of aquarium. Limitation of resources used for WEC in Malaysia also a big challenge in this project. The material such as permanent magnet and enameled wire is difficult to obtain in Malaysia. Only a certain places provided such materials and it is quite expensive.

Moreover, the results show that this prototype can produce certain amount of voltage and current which verify and prove the concept of wave energy conversion. As a conclusion, marine renewable energy can be one of the most important energy generators in the future because of its potential to convert wave energy into electricity.

## **5.2 Recommendations**

Although the prototype had been successfully done and proved, there are still a lot more improvements that can be added. For example, further study on the permanent magnet need to be done because this permanent magnet is very expensive. If the system is going to be implemented in real situation, there will be a lot of expenses needed. One of the ways is to build electromagnetic that can produce the same behavior of magnetic flux as permanent magnet material. This may cost cheaper rather than using the permanent magnet itself. Next improvement can be done by using a lot of linear motion generator rather than just one. This may improve the produced voltage and current. Furthermore, it is recommended to build and compare another system of wave energy conversion in order to know the best energy conversion among all the possible methods.

## REFERENCES

- [1] (n.d.). Retrieved August 16, 2010, from <http://projects.wri.org/sd-pams-database/malaysia/energy-efficiency-and-renewable-energy-ninth-malaysia-plan-2006-2010>
- [2] K.Rhinefrank, E.B.Agamloh, A. von Jounne, \*, A.K Wallace, J. Prudell, K.Kimble, J.Aills, E.Schmidt, P.Chan, B.Sweeny, A.Schacher, "Novel Ocean Energy Permanent Magnet Linear Generator Buoy", *Oregon State University*, Corvallis, 12 May 2005
- [3] Omar Yaakob, Tengku Mohd Ariff bin Tengku Ab Rashid, and Mohamad Afifi Abdul Mukti, "Prospects for Ocean Energy in Malaysia" in Proc. Of International Conference on Energy and Environment 2006 Bangi, Malaysia (ICEE 2006), 28-30 August 2006, pp. 66-67
- [4] Carbon Trust, Future Marine Energy. Results of the Marine Energy Challenge: Cost competitiveness and growth of wave and tidal stream energy, January 2006
- [5] J. Falnes and K. Budal. Wave power conversion by point absorbers. *Norwegian Maritime Research*, 6(4):2–11, 1987.
- [6] S. Salter. Power conversion systems for ducks. In *International conference on future energy concepts*, volume 171, page 100–108, 1979.
- [7] A. Clément, P. McCullen, A. Falcaõ, A. Fiorentino, F. Gardner, K. Hammarlund, G. Lemonis, T. Lewis, K. Nielsen, S. Petroncini, M.T. Pontes, P. Schild, B.O. Sjöström, H.C. Sørensen, and T. Thorpe. Wave energy in europe: current status and perspectives. *Renewable and Sustainable Energy Reviews*, 6(5):405–431, 2002.
- [8] Joao Cruz, "Ocean Wave Energy", Springer-Verlag Berlin Heidelberg 2008, 1-3
- [9] Robert H. Clark, "Elements of Tidal-Electric Engineering", *IEEE Press*

*Editorial Board 2007, 8-13*

- [10] (n.d.). Retrieved September 18, 2010, from <http://www.wavegen.co.uk>.
- [11] (n.d.). Retrieved October 20, 2010, from <http://www.oceanpd.com>
- [12] (n.d.). Retrieved October 20, 2010, from <http://www.aquaenergygroup.com>
- [13] J. Vining, "Ocean Wave Energy Conversion", *Advanced Independent Study Report Electrical and Computer Engineering Department University of Wisconsin – Madison* , December 2005
- [14] Michael Allard, Colin Fischer, Tania Grindrod, Jessica Murray, Kyle Russ, "Wave Energy", *Mechanical Engineering Department University of New Hampshire*, April 25, 2008
- [15] Sadiku, M. N. O. (2007). *Elements of Electromagnetics* (fourth ed.). New York (USA)/Oxford (UK): Oxford University Press. p. 386. ISBN 0-19-530048-3
- [16] (n.d.). Retrieved March 8, 2010, from [http://www.allaboutcircuits.com/vol\\_3/chpt\\_3/4.html](http://www.allaboutcircuits.com/vol_3/chpt_3/4.html)

# APPENDIX A

## GANTT CHART FOR FINAL YEAR PROJECT 2

No.	Detail/ Week	1	2	3	4	5	6	7	8	9	10	11	12	13	14	15	16	17	18	19	20	
1	Designing the prototype																					
2	Fabricating the prototype																					
3	Testing the prototype																					
4	Progress Report																					
5	Methodology update and data collection																					
6	Literature review update																					
7	Conclusion and recommendation update																					
8	Draft report																					
9	Final report and technical report (soft cover)																					
10	Viva																					
11	Final report (hard cover)																					
12																						

M I D S E M S E S T E R B R E A K  
 S T U D Y W E E K W E E K  
 E X A M W E E K

## APPENDIX B

Current, Output	
Time ( s )	Current ( A )
0	0.116
0.1	0.106
0.2	3.05E-04
0.3	-0.028
0.4	-0.167
0.5	3.66E-04
0.6	0.259
0.7	-0.253
0.8	0.018
0.9	0.23
1	-0.205
1.1	0.032
1.2	0.246
1.3	-0.233
1.4	0.036
1.5	0.233
1.6	-0.16
1.7	0.03
1.8	0.278
1.9	-0.226
2	0.057
2.1	0.042
2.2	-0.093
2.3	0.117
2.4	-0.044
2.5	-0.058
2.6	0.116
2.7	-0.081
2.8	-0.062
2.9	0.046
3	0.248
3.1	-0.249
3.2	5.49E-04
3.3	0.258

3.4	-0.293
3.5	0.02
3.6	0.057
3.7	0.237
3.8	-0.231
3.9	3.05E-04
4	0.204
4.1	-0.245
4.2	-0.047
4.3	0.061
4.4	0.197
4.5	-0.181
4.6	0.055
4.7	0.211
4.8	-0.263
4.9	-5.01E-03
5	0.138
5.1	-0.117
5.2	-0.066
5.3	0.098
5.4	0.04
5.5	-0.126
5.6	0.056
5.7	0.223
5.8	-0.237
5.9	5.49E-04
6	0.277
6.1	-0.229
6.2	-0.037
6.3	0.072
6.4	0.153
6.5	-0.164
6.6	4.27E-04
6.7	0.254
6.8	-0.288
6.9	6.23E-03
7	0.175
7.1	-0.139
7.2	-0.063
7.3	0.179

7.4	-0.096
7.5	-0.092
7.6	0.013
7.7	0.294
7.8	-0.294
7.9	1.22E-04
8	0.271
8.1	-0.258
8.2	-0.048
8.3	0.145
8.4	-0.125
8.5	-0.06
8.6	0.059
8.7	0.231
8.8	-0.186
8.9	-2.44E-04
9	0.08
9.1	0.163
9.2	-0.166
9.3	-0.079
9.4	3.66E-04
9.5	0.296
9.6	-0.267
9.7	-0.022
9.8	0.209
9.9	-0.242
10	-0.036
10.1	0.04
10.2	0.185
10.3	-0.172
10.4	-0.092
10.5	0.033
10.6	0.251
10.7	-0.238
10.8	-2.44E-04



## APPENDIX C

Voltage, Output	
Time ( s )	Voltage ( V )
0	-0.408
0.1	-1.837
0.2	0.29
0.3	0.697
0.4	0.371
0.5	-0.409
0.6	-1.058
0.7	0.072
0.8	1.378
0.9	0.407
1	-0.147
1.1	-1.227
1.2	-0.662
1.3	1.617
1.4	0.363
1.5	-0.711
1.6	-1.23
1.7	0.333
1.8	1.355
1.9	0.265
2	-2.44E-03
2.1	-0.757
2.2	-1.626
2.3	1.808
2.4	0.341
2.5	-0.502
2.6	-2.039
2.7	1.353
2.8	0.797
2.9	0.142
3	-0.358
3.1	-1.984
3.2	1.634
3.3	0.7

3.4	-0.474
3.5	-1.708
3.6	0.906
3.7	0.987
3.8	0.134
3.9	-8.55E-03
4	-1.451
4.1	0.142
4.2	1.231
4.3	-6.10E-03
4.4	-1.905
4.5	0.388
4.6	0.972
4.7	0.172
4.8	-0.414
4.9	-1.82
5	1.842
5.1	0.533
5.2	-0.116
5.3	-1.948
5.4	0.848
5.5	1.141
5.6	0.142
5.7	-0.225
5.8	-1.854
5.9	1.127
6	0.917
6.1	-3.66E-03
6.2	-1.635
6.3	0
6.4	1.426
6.5	0.278
6.6	-4.88E-03
6.7	-0.682
6.8	-1.579
6.9	1.643
7	0.732
7.1	-5.49E-03
7.2	-1.599
7.3	-0.357

7.4	1.281
7.5	0.455
7.6	0.063
7.7	-0.732
7.8	-1.395
7.9	2.122
8	0.293
8.1	-0.537
8.2	-1.95
8.3	1.092
8.4	0.979
8.5	0.142
8.6	-0.146
8.7	-1.399
8.8	-0.301
8.9	1.297
9	0.157
9.1	-1.197
9.2	-0.554
9.3	1.226
9.4	0.51
9.5	-5.49E-03
9.6	-1.091
9.7	-0.655
9.8	1.813
9.9	0.179
10	-0.756
10.1	-1.599
10.2	1.794
10.3	0.49
10.4	-2.44E-03
10.5	-0.64
10.6	-1.71
10.7	2.403
10.8	0.214

## APPENDIX D

Voltage, Battery	
Time ( s )	Voltage ( V )
0	1.759
0.1	1.757
0.2	2.17
0.3	2.053
0.4	2.011
0.5	2.052
0.6	2.015
0.7	2.208
0.8	2.222
0.9	2.142
1	2.267
1.1	2.25
1.2	2.308
1.3	2.216
1.4	2.281
1.5	2.213
1.6	2.299
1.7	2.318
1.8	2.256
1.9	2.437
2	2.329
2.1	2.504
2.2	2.348
2.3	2.448
2.4	2.377
2.5	2.537
2.6	2.404
2.7	2.656
2.8	2.517
2.9	2.685
3	2.535
3.1	2.623
3.2	2.553
3.3	2.808

3.4	2.559
3.5	2.647
3.6	2.586
3.7	2.698
3.8	2.559
3.9	2.561
4	2.522
4.1	2.647
4.2	2.551
4.3	2.597
4.4	2.564
4.5	2.637
4.6	2.607
4.7	2.9
4.8	2.657
4.9	2.715
5	2.656
5.1	2.668
5.2	2.654
5.3	2.74
5.4	2.706
5.5	2.628
5.6	2.901
5.7	2.694
5.8	2.756
5.9	2.665
6	2.705
6.1	2.653
6.2	2.656
6.3	2.639
6.4	2.701
6.5	2.666
6.6	2.783
6.7	2.703
6.8	2.667
6.9	2.681
7	2.636
7.1	2.613
7.2	2.774
7.3	2.657

7.4	2.623
7.5	2.66
7.6	2.626
7.7	2.778
7.8	2.698
7.9	2.639
8	2.924
8.1	2.723
8.2	2.667
8.3	2.77
8.4	2.701
8.5	2.767
8.6	2.803
8.7	2.719
8.8	2.683
8.9	2.661
9	2.641
9.1	2.77
9.2	2.684
9.3	2.654
9.4	2.633
9.5	2.62
9.6	2.608
9.7	2.597
9.8	2.587
9.9	2.597
10	2.582
10.1	2.573
10.2	2.573
10.3	2.564
10.4	2.554
10.5	2.849
10.6	2.697
10.7	2.657
10.8	2.634
10.9	2.766
11	2.676
11.1	2.655
11.2	2.71
11.3	2.666

11.4	2.859
11.5	2.716
11.6	2.68
11.7	2.856
11.8	2.731
11.9	2.695
12	2.676
12.1	2.876
12.2	2.736
12.3	2.701
12.4	2.771
12.5	2.72
12.6	2.785
12.7	2.773
12.8	2.715
12.9	2.687
13	2.8
13.1	2.734
13.2	2.915
13.3	2.808
13.4	2.744
13.5	3.023
13.6	2.805
13.7	2.815
13.8	2.849
13.9	2.768
14	2.746
14.1	2.863
14.2	2.79
14.3	2.879
14.4	2.783
14.5	2.86
14.6	2.823
14.7	2.768
14.8	2.773
14.9	2.892
15	2.778
15.1	3.003
15.2	2.794
15.3	2.755

15.4	2.872
15.5	2.803
15.6	2.756
15.7	2.832
15.8	2.779
15.9	2.744
16	2.765
16.1	2.741
16.2	2.776
16.3	2.845
16.4	2.759
16.5	2.785
16.6	2.753
16.7	2.724
16.8	2.891
16.9	2.754
17	2.727
17.1	2.721
17.2	2.72
17.3	2.701
17.4	2.794
17.5	2.758
17.6	2.726
17.7	2.821
17.8	2.748
17.9	2.722
18	2.932
18.1	2.799
18.2	2.763
18.3	2.864
18.4	2.795
18.5	2.764
18.6	2.784
18.7	2.759
18.8	2.739
18.9	2.753
19	2.73
19.1	2.715
19.2	2.705
19.3	2.695



19.4	2.686
19.5	2.676
19.6	2.671
19.7	2.665

## APPENDIX E

Voltage, Capacitor	
Time ( s )	Voltage ( V )
0	0.83
0.1	0.831
0.2	0.829
0.3	0.831
0.4	0.831
0.5	0.829
0.6	0.831
0.7	0.831
0.8	0.829
0.9	0.834
1	0.831
1.1	0.881
1.2	0.839
1.3	0.834
1.4	0.872
1.5	0.834
1.6	0.835
1.7	0.992
1.8	0.84
1.9	0.844
2	0.837
2.1	0.835
2.2	0.836
2.3	0.84
2.4	0.84
2.5	0.837
2.6	0.836
2.7	0.836
2.8	0.886
2.9	0.838
3	0.864
3.1	0.836
3.2	0.836
3.3	0.913
3.4	0.84
3.5	0.839

3.6	0.84
3.7	0.84
3.8	0.881
3.9	0.842
4	0.84
4.1	0.939
4.2	0.842
4.3	0.842
4.4	0.847
4.5	0.842
4.6	0.909
4.7	0.845
4.8	0.843
4.9	1.121
5	0.85
5.1	0.908
5.2	0.85
5.3	0.847
5.4	1.038
5.5	0.85
5.6	0.849
5.7	0.854
5.8	0.85
5.9	1
6	0.853
6.1	0.85
6.2	0.856
6.3	0.85
6.4	1.017
6.5	0.859
6.6	0.855
6.7	0.86
6.8	0.855
6.9	0.908
7	0.859
7.1	0.856
7.2	0.864
7.3	0.858
7.4	0.894
7.5	0.864

7.6	0.859
7.7	0.866
7.8	0.859
7.9	0.859
8	0.864
8.1	0.861
8.2	1.016
8.3	0.862
8.4	0.86
8.5	0.868
8.6	0.863
8.7	1.054
8.8	0.864
8.9	0.862
9	0.873
9.1	0.865
9.2	0.864
9.3	0.869
9.4	0.864
9.5	0.864
9.6	0.867
9.7	0.864
9.8	0.861
9.9	0.996
10	0.864
10.1	0.864
10.2	0.892
10.3	0.864
10.4	0.861
10.5	0.859
10.6	0.859
10.7	0.864
10.8	0.861
10.9	0.859
11	0.942
11.1	0.861
11.2	0.859
11.3	0.914
11.4	0.865
11.5	0.862

11.6	1.097
11.7	0.869
11.8	0.864
11.9	0.927
12	0.865
12.1	0.918
12.2	0.87
12.3	0.867
12.4	0.879
12.5	0.868
12.6	0.867
12.7	0.871
12.8	0.867
12.9	0.865
13	0.864
13.1	0.869
13.2	0.866
13.3	0.864
13.4	0.869
13.5	0.864
13.6	0.863
13.7	0.863
13.8	0.869
13.9	0.865
14	0.865
14.1	0.869
14.2	0.866
14.3	0.864
14.4	0.952
14.5	0.867
14.6	0.866
14.7	1.013
14.8	0.868
14.9	0.866
15	0.967
15.1	0.87
15.2	0.866
15.3	0.916
15.4	0.866
15.5	0.866

15.6	0.865
15.7	0.917
15.8	0.867
15.9	0.923
16	0.868
16.1	0.866
16.2	0.866
16.3	0.869
16.4	0.868
16.5	0.937
16.6	0.87
16.7	0.865
16.8	0.865
16.9	0.871
17	0.869
17.1	0.94
17.2	0.87
17.3	0.866
17.4	0.988
17.5	0.869
17.6	0.869
17.7	0.979
17.8	0.872
17.9	0.869
18	1.044
18.1	0.873
18.2	0.87
18.3	0.897
18.4	0.869
18.5	0.869
18.6	0.958
18.7	0.87
18.8	0.869
18.9	0.871
19	0.87
19.1	0.869
19.2	0.958
19.3	0.87
19.4	0.869
19.5	0.904

19.6	0.87
19.7	0.869
19.8	0.986
19.9	0.872
20	0.87
20.1	0.888
20.2	0.87
20.3	0.869
20.4	0.977
20.5	0.87
20.6	0.869
20.7	0.874
20.8	0.87
20.9	0.869
21	0.94
21.1	0.87
21.2	0.869
21.3	0.957
21.4	0.87
21.5	0.869
21.6	0.928
21.7	0.869
21.8	0.869
21.9	0.889
22	0.869
22.1	0.869
22.2	0.87
22.3	0.869
22.4	0.869
22.5	0.912
22.6	0.869
22.7	0.869
22.8	0.956
22.9	0.869
23	0.869
23.1	0.879
23.2	0.869
23.3	0.868
23.4	0.878
23.5	0.867

23.6	0.867
23.7	0.947
23.8	0.869
23.9	0.869
24	0.869
24.1	0.87
24.2	0.869
24.3	0.938
24.4	0.869
24.5	0.869
24.6	0.869
24.7	0.873
24.8	0.869
24.9	0.869
25	0.876
25.1	0.873
25.2	0.872
25.3	0.884
25.4	0.874
25.5	0.873
25.6	0.879
25.7	0.874
25.8	0.874
25.9	0.932
26	0.877
26.1	0.874
26.2	0.874
26.3	0.872
26.4	0.87
26.5	0.87
26.6	0.877
26.7	0.873
26.8	0.872
26.9	0.875
27	0.872
27.1	0.872
27.2	0.884
27.3	0.876
27.4	0.874
27.5	0.885



27.6	0.879
27.7	0.921
27.8	0.879
27.9	0.876
28	0.875
28.1	0.885
28.2	0.88
28.3	0.877
28.4	0.885
28.5	0.878
28.6	0.875
28.7	0.924
28.8	0.877
28.9	0.875
29	0.938
29.1	0.879
29.2	0.879
29.3	0.881
29.4	0.878
29.5	0.876
29.6	0.876
29.7	0.874
29.8	0.874
29.9	0.913
30	0.874
30.1	0.874
30.2	0.873
30.3	0.878
30.4	0.875
30.5	0.873
30.6	0.886
30.7	0.878
30.8	0.877
30.9	0.875
31	0.879
31.1	0.879
31.2	0.875
31.3	0.914
31.4	0.878
31.5	0.875

31.6	0.875
31.7	0.878
31.8	0.876
31.9	0.874
32	0.914
32.1	0.876
32.2	0.875
32.3	0.875
32.4	0.923
32.5	0.878
32.6	0.875
32.7	0.955
32.8	0.879
32.9	0.878
33	0.965
33.1	0.882
33.2	0.878
33.3	0.903
33.4	0.879
33.5	0.878
33.6	0.925
33.7	0.878
33.8	0.876
33.9	0.876
34	0.917
34.1	0.88
34.2	0.878
34.3	0.878
34.4	0.917
34.5	0.878
34.6	0.875
34.7	0.875
34.8	0.922
34.9	0.876
35	0.875
35.1	0.875
35.2	0.875
35.3	0.974
35.4	0.88
35.5	0.88

35.6	0.876
35.7	0.876
35.8	0.88
35.9	0.879
36	0.876
36.1	0.882
36.2	0.875
36.3	0.875
36.4	0.875
36.5	0.874