

**Reliability Block Diagram Method for RAM Study of Dehydration
Unit**

By

TENGGU IBRAHIM BIN TENGGU MUHAMMAD

11009

Dissertation

Submitted in partial fulfillment of the
requirements for the
Bachelor of Engineering (Hons)
(Mechanical Engineering)

SEPT 2011

Universiti Teknologi PETRONAS
Bandar Seri Iskandar
31750 Tronoh
Perak Darul Ridzuan

CERTIFICATION OF ORIGINALITY

This is to certify that I am responsible for the work submitted in this project, that the original work is my own except as specified in the references and acknowledgements, and that the original work contained herein have not been undertaken or done by unspecified sources or persons.



TENGGU IBRAHIM BIN TENGKU MUHAMMAD

ABSTRACT

Reliability, Availability and Maintainability (RAM) can make a huge difference in the plant sector. Maintenance with support of good RAM analysis can help in reducing the system unavailability and its effect. For this project, RAM analysis will be done using Reliability Block Diagram (RBD) technique. The data involved will be the time to failure and time to repair data. The analysis can help to identify critical components that can affect the whole system reliability. From that, further planning in terms of maintenance and improvement can be done. With a good modeling and analysis, it is possible to make availability improvement. The research will be based on the Dehydration Unit (DHU) of a Gas Processing Plant (GPP). DHU is essential in a GPP to remove water from then natural gas. If the water is not being removed, it will affect the transmission and the processing of the gas.

ACKNOWLEDGEMENT

In the name of Allah, the Most Gracious, the Most Merciful. Praise to Him the Almighty that in his will and given strength, the author managed to complete this final year project within the time required.

Deepest gratitude to the author's family, who is always giving moral support and encouragement that has been a great inspiration to the author.

Many thanks to the supervisor, Dr. Ainul Akmar binti Mokhtar, for her supervision, support, and advice not only in project matter but also for the future life and employment. She also spends countless hours in sharing knowledge and valuable experiences throughout the supervision. With her guidance, the project can properly be done without a lot of problem.

I am also thankful to PETRONAS Gas Berhad especially to Mr. Ameruddin bin Shahrin for the assistance he gives on the plant operation and equipment. Not to forget the technicians of MTA department for their willingness in teaching all necessary knowledge, procedures and helped me to understand more on gas processing plant. These people are so kind with me and helped me a lot in completing this report. Thanks to all my fellow friends and everyone who have directly or indirectly lent a helping hand here and there.

Last but not least, the author would like to express gratitude to the proposal defense examiner, Dr Aklilu Tesfamichael and Mr Masdi for his advice and concern has helped the author in improving the final year project.

May Allah bless and pay them all.

TABLE OF CONTENT

CERTIFICATION.....	i
ABSTRACT.....	iii
ACKNOWLEDGEMENT.....	iv
LIST OF FIGURES.....	vi
LIST OF TABLES.....	vi
ABBREVIATIONS AND NOMENCLATURE.....	vii
CHAPTER 1: INTRODUCTION.....	1
1.1 Background of study.....	1
1.2 Problem Statement.....	2
1.3 Objective.....	3
1.4 Scope of study.....	3
1.5 Relevancy of the project.....	3
CHAPTER 2: LITERATURE REVIEW.....	4
2.1 Natural gas.....	4
2.2 Gas dehydration.....	6
2.3 Type of dehydration unit.....	7
2.4 Reliability, Availability and Maintainability.....	8
2.5 Reliability Block Diagram.....	14
CHAPTER 3: METHODOLOGY.....	16
3.1 Research methodology.....	17
3.2 Data Analysis.....	19
3.3 Reliability Block Diagram.....	21
3.4 Software.....	24
3.5 Timelines for FYP 1.....	29
3.6 Timelines for FYP 2.....	30
CHAPTER 4: RESULT AND DISCUSSION.....	31
4.1 Reliability Block Diagram.....	31
4.2 Static Reliability.....	32
4.3 OREDA.....	37
CHAPTER 5: CONCLUSION AND RECOMMENDATION.....	49
5.2 Conclusion.....	49
5.1 Recommendation.....	50
REFERENCES.....	51
APPENDICES.....	53

LIST OF FIGURES

Figure 1.1: The Gas Processing Plant.....	1
Figure 2.1: The natural gas used.....	4
Figure 2.2: Natural gas market chain.....	5
Figure 2.3: Bathtub Curve.....	9
Figure 2.4: Flowchart for System Availability Evaluation (Carazas et al. 2009).....	13
Figure 2.5: Series System.....	14
Figure 2.6: Parallel System.....	15
Figure 3.1: Research Methodology Flowchart.....	18
Figure 3.2: Data Analyze Flowchart.....	16
Figure 3.3: DHU Diagram.....	18
Figure 3.4: Input data for static reliability.....	25
Figure 3.5: Selecting exponential distribution in Block-sim.....	25
Figure 3.6: Input data for exponential distribution.....	26
Figure 3.7: Computing the reliability.....	26
Figure 3.8: Generating Graph.....	27
Figure 3.9: Sample graph.....	27
Figure 3.11: Maintainability/Availability simulation.....	28
Figure 3.10: Input data for corrective maintenance.....	28
Figure 3.10: Gantt chart for FYP 1.....	29
Figure 3.11: Gantt chart for FYP 2.....	30
Figure 4.1: First draft of RBD.....	32
Figure 4.2: RBD for DHU.....	33
Figure 4.3: RBD for regeneration system.....	33

LIST OF TABLES

Table 4.1: Static reliability data.....	34
Table 4.2: Static reliability result.....	35
Table 4.3: What-if analysis result for DHU.....	36
Table 4.4: What-if analysis result for regeneration system.....	36
Table 4.5: Data collection (mean failure rate).....	39
Table 4.6: Result for calculation (mean failure rate).....	40
Table 4.7: Data collection (upper failure rate).....	41
Table 4.8: Result for calculation (Upper failure rate).....	42
Table 4.9: Increasing the reliability.....	43
Table 4.10: Optimizing DHU (excluding regeneration system).....	44
Table 4.11: Optimizing DHU (including regeneration system).....	44
Table 4.12: Optimizing regeneration system.....	45
Table 4.13: Repair (manhours).....	46
Table 4.14: System overview.....	46
Table 4.15: Block availability ranking.....	47
Table 4.16: Block downtime ranking.....	48

ABBREVIATIONS AND NOMENCLATURE

DEG	Diethylene Glycol
DHU	Dehydration Unit
GPP	Gas Processing Plant
MTBF	Mean Time Between Failure
MTTF	Mean Time To Failure
MTTFF	Mean Time To First Failure
NGL	Natural Gas Liquid
NOF	Number Of Failure
OREDA	Offshore Reliability Data
PGB	PETRONAS Gas Berhad
RAM	Reliability, Availability and Maintainability
RBD	Reliability Block Diagram
TEG	Triethylene Glycol

1. INTRODUCTION

1.1. Background of Study

This study is focusing on the dehydration unit in the Gas Processing Plant (GPP). GPP consists of 5 units. They are Pre-treatment Unit (PTU), Dehydration Unit (DHU), Low Temperature Separation Unit (LTSU), Product Recovery Unit (PRU) and Acid Gas Removal Unit (AGRU). GPP is used to process natural gas to obtain methane, ethane, propane, and butane. Usually, the gas will contain significant quantities of water and other impurities. The gas will go through PTU, AGRU and DHU in GPP to filter out the unwanted component in the gas. Figure 1.1 represents the 5 units in GPP and the function of each unit. The DHU is located at the last filtering process before the plant started to extract product. After DHU, there will be only pure hydrocarbon gas in the pipeline.

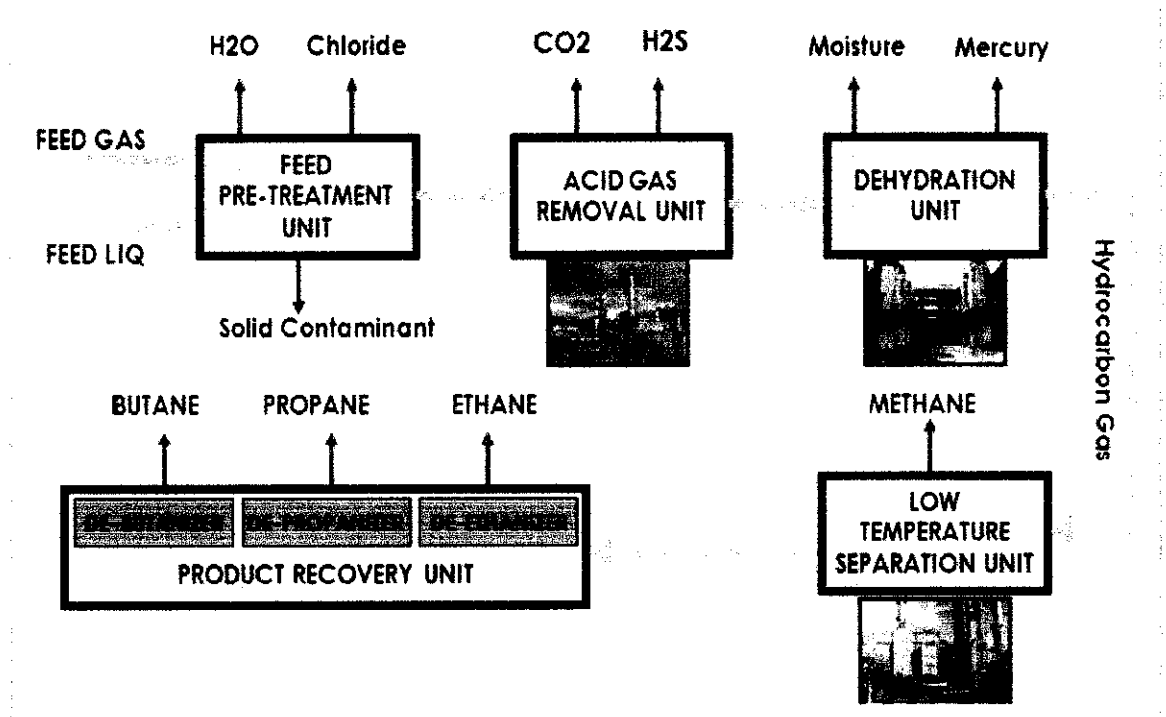

Figure 1.1: The Gas Processing Plant (PETRONAS Gas mechanical note, 2010)

DHU in GPP is used to remove water and mercury from the natural gas. Kidnay and Parrish (2006) suggested that “Water needs to be removed to reduce pipeline corrosion and eliminate line blockage caused by hydrate formation. The water dew point should be below the lowest pipeline temperature to prevent free water formation”.

It is very important to ensure the water is being removed from the natural gas. For that purpose, the equipment in this unit need to continue working in a good condition. Therefore the equipment need to be well maintained throughout the process. An effective maintenance not only keeps the equipment ‘healthy’ but will prolong the lifespan of equipment. Hence this will increase the equipment availability.

Reliability, availability and maintainability (RAM) modeling can be used to evaluate system availability and downtime hence detects the problem that reduces the availability in the system. The Reliability Block Diagram (RBD) of DHU will be constructed. Once the RBD is done, the failure rate, the mean time between failure (MTBF), reliability and availability of the system can be calculated.

1.2. Problem Statement

In this competitive world, failure and its effect are becoming increasingly intolerable. In a big plant such as in PGB, equipment failure will lead to reduction in output. Even a small breakdown can lead to a big lost. In order to prevent that from happen, a good maintenance with reliability engineering technology is needed. The need to understand what causes of the failure and what action need to be taken to prevent it or reduce its effect are the main challenges to the engineer. Having a maintenance strategy to manage assets effectively and optimized preventive maintenance programme will ensure the equipment to operate with minimum downtime throughout the process. Before such strategy being plan, it is important to do research in term of RAM of the equipment and system first. The development of a quantitative RAM model is expected to increase the efficiency and effectiveness of preventive and corrective maintenance actions and hopefully can assist in increase plant reliability and less unexpected output loses. Understanding RAM model of a

system or equipment and the effect of different sub-system configurations is important and can assist in achieving the required goals in the most economical manner.

1.3. Objective

The main objectives of this research

- To assess system reliability and availability for DHU in GPP

The sub-objectives to achieve the main objective

- To identify equipments and their relationship of each other in term of reliability in DHU
- To build reliability-block diagram for DHU
- To work on reliability and availability analysis for DHU

1.4. Scope of study

There are 5 main units in gas processing plant. There are Pre-treatment Unit, Dehydration Unit, Low Temperature Separation Unit, Product Recovery Unit and Acid Gas Removal Unit. This study will be focus on the DHU and the equipments involved in the system. To simplify the research, the piping will not be included in the case study.

1.5. Relevancy of the project

Reliability in the plant has become important issues to this challenging world. A proper RAM analysis can be used to help maintenance process. In addition, this can reduce the frequency of failures, optimize the availability of the system and minimize the effect of unavailability. In the economic point of view, failures and unavailability can reduce plant production. Thus it will automatically reduce the profit gain by the plant.

2. LITERATURE REVIEW

2.1. Natural Gas

Natural gas plays a vital role in the world's supply of energy. For Malaysia, natural gas has become the backbone for the country's electricity. Even though there is other energy source such as hydroelectric and coal, the natural gas still the country's largest supplier for electricity. Besides contributing in energy sector, there are other used for natural gas such as in making various types of plastic and in petrochemical manufacturing, natural gas is used to produce hydrogen, sulfur, carbon black, and ammonia. Natural gas is a combustible mixture of hydrocarbon gases. Natural gas is formed primarily of methane and also includes ethane, propane, butane and condensate. Methane and Ethane are also known as sales gas as they are the hydrocarbon that required in generating electricity while other gas will be the bonus for the plant to gain profit in other products. Figure 2.1 show that the natural gas is largely being used for electricity and industrial purposes.

Natural Gas Use, 2010

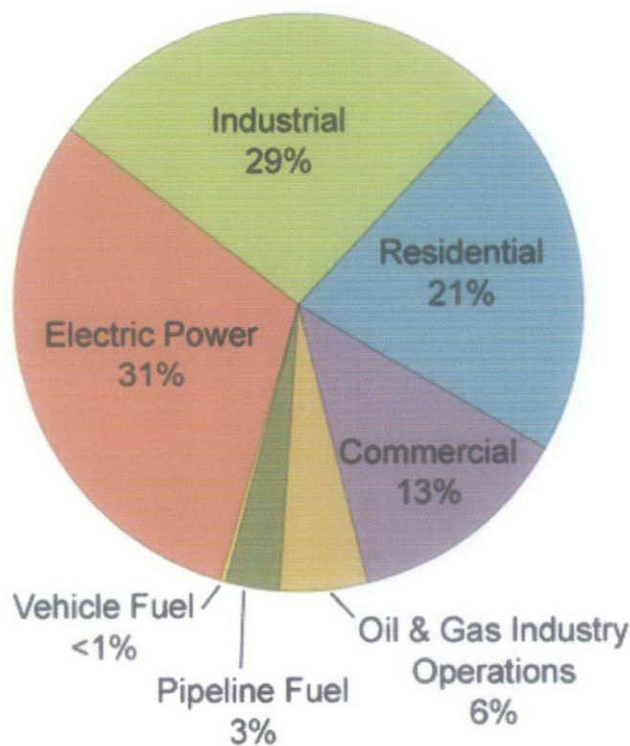

Figure 2.1: The natural gas used (U. S. Energy Information Administration, Natural Gas Monthly, April 2011)

Figure 2.2 illustrates the position and function of natural gas gathering and processing and natural gas liquid (NGL) logistics and marketing within the natural gas market chain.

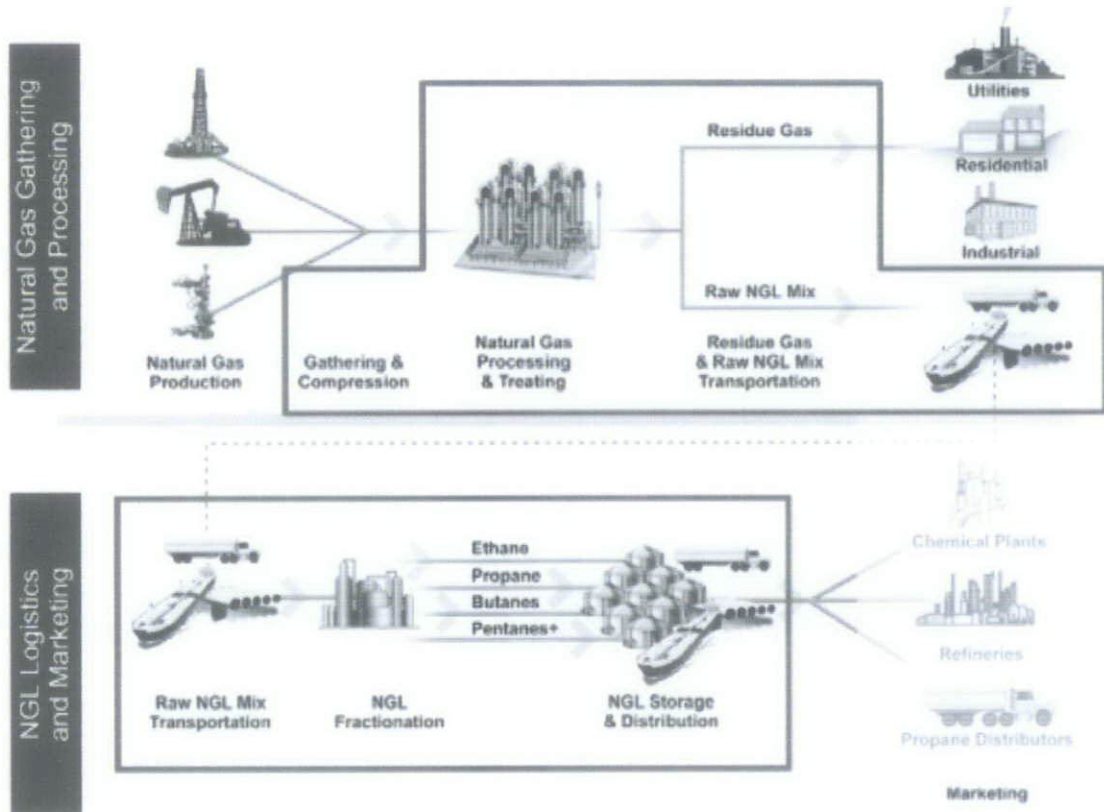

Figure 2.2: Natural gas market chain (TARGA Resources Partners LP, 2010)

Natural gas production is generally associated with crude oil and water. Hence a primary separation is made in the field. The separation is to separate the oil and the natural gas. After the separation, the oil and natural gas will be sent to their respective plant for further process. As for natural gas, it will be sent to the GPP. At GPP, the natural gas will go through various processes before extracting the required product. The process that being use to gain the product is known as the distillation process. Natural gas from the field contains condensable water and hydrocarbons, such as ethane and heavier hydrocarbons (C6+). However the filtering process will not occur at the field hence that the reason the natural gas sent to the GPP.

2.2. Gas Dehydration

Under normal production conditions, the natural gas is saturated with water vapor. It is necessary to prevent the condensation of liquid water and hydrocarbons to ensure trouble-free operation of a natural gas transmission system. Apart from the risk of hydrate formation, the liquids can reduce the volumetric capacity of the system and interfere with the operation of pressure regulators and filters. Condensed liquids accumulated in pipelines, which caused an increase in operating pressures and potential damage to equipment due to liquid carryover. Gandhidasan (2003).

In order to remove the water in the natural gas, dehydration unit has been created in the GPP. It has become one of the main units on the GPP. The natural gas will go through the DHU before getting the product. DHU is very essential for any gas processing plant. Research has proved that it is necessary to remove water in the natural gas. Operating experience and thorough engineering have proved that it is necessary to reduce and control the water content of gas to ensure safe processing and transmission, Mokhatab et al. (2006) has list four major reasons as follow:-

- Natural gas in the right conditions can combine with liquid or free water to form solid hydrates that can plug valves fittings or even pipelines.
- Water can condense in the pipeline, causing slug flow and possible erosion and corrosion.
- Water vapor increases the volume and decreases the heating value of the gas.
- Sales gas contracts and/or pipeline specifications often have to meet the maximum water content of 7 lb H₂O per MMscf.

DHU is not the same for all GPP in the world. It depends on the capacity of the gas that is going to be processed and other aspects. There are several techniques can be used to remove water from natural gas. According to Gandhidasan et al (2001), “two types of dehydration equipment are in current use: they are absorption by liquid desiccants and adsorption by solid desiccants. The unit is called a liquid desiccant dehydrator and a solid desiccant dehydrator respectively.”

2.3. Type of Dehydration Unit

The two methods, liquid desiccants and solid desiccants is widely used in the current GPP. The two methods utilize mass transfer of the water molecule into a liquid solvent or a crystalline structure. However, there is the third method. It is refrigeration (i.e., cooling the gas). Mokhatab et al. (2006) said, “The third method employs cooling to condense the water molecule to the liquid phase with the subsequent injection of inhibitor to prevent hydrate formation. However, the choice of dehydration method is usually between glycol and solid desiccants”. The other unpopular dehydration technologies are membranes, vortex tube, and supersonic processes.

Liquid desiccant uses certain liquid as water absorber. Calcium chloride, lithium chloride and glycols can be used to absorb water in the natural gas. Solid desiccant dehydration is using the principal of adsorption. Adsorbents used include silica gel, alumina, molecular sieve and charcoal. Adsorption involves a form of adhesion between the surface of the solid desiccant and the water vapor in the gas. The water molecules are held to the desiccant surface by forces of attraction. Opposite to liquid desiccant, the solid desiccant does not involve any chemical reaction. It is a pure surface phenomenon.

Nowdays, the method that usually being used by GPP is the liquid desiccants by using Triethylene Glycol (TEG). Mokhatab et al. (2009) said that “design of gas dehydration unit will be usually based on conventional TEG dehydration process”. The reason is that the TEG system is rather cheaper than other methods. Even though DEG is cheaper to buy, but it has a larger carryover loss, offers less dew point depression, and regeneration to high concentration is more difficult compare to TEG. For these reasons, TEG is much preferable rather than other glycol.

2.4. Reliability, Availability and Maintainability

Gupta et al. (2009) stated that “system availability gives a measure of how well a system performs or meets its design objectives. For increasing the productivity, availability and reliability of equipment / subsystems in operation must be maintained at highest order”. The availability analysis is proved to be important to ensure the equipment to continue to work with low failure.

For a gas processing plant, RAM modeling need to be done in order to improve their production. Kawauchi et al. (2004) have done the RAM approach in their project to extend the gas processing plant life. “RAM study was applied to the GPP-1 facilities dedicated to sales gas production only as achieving high availability of sales gas production is a primary objective of GPP-1”. From their study, they can determine which critical equipment need detail inspection, ensure sufficient plant shutdown duration and equipment reliability.

There are several ways to do RAM modeling. Based on Dhillon and Yang (1997), there are many methods available to evaluate reliability of engineering systems. The two widely used methods are the reliability block diagram and Markov processes. As the title for this project, the author will use the reliability block diagram method in doing the analysis.

Cox and Tait (1998) define reliability as the probability that an item will perform its function under stated conditions for a stated period of time. Based on Eti et al. (2007), reliability is the probability of the equipment or process functioning without failure, when operated as prescribed for a given interval of time, under stated conditions. When talking about probability, the value should be between 0 to 1. High reliability mean the equipment can run with a very unlikely to fail for a period of time. All the plant management is targeting to have high reliability of plant system as it can reduce expenditure and maximize the income.

The basic unit to measure reliability is the failure rate. From Heizer and Render (2011), failure rate is measured as the percent of failures among the total number of product tested or a number of failures during a period of time.

$$FR (\%) = \frac{\text{Number of failures}}{\text{Number of unit tested}} \times 100\%$$

$$FR (N) = \frac{\text{Number of failures}}{\text{Number of unit-hours of operation time}}$$

Term that usually used in reliability is the mean time between failures (MTBF) which is reciprocal of FR (N)

$$MTBF = \frac{1}{FR (N)}$$

In general, there are three types of failure rate in term of its trend over time. Figure 2.3 showed the trend of the failure rate.

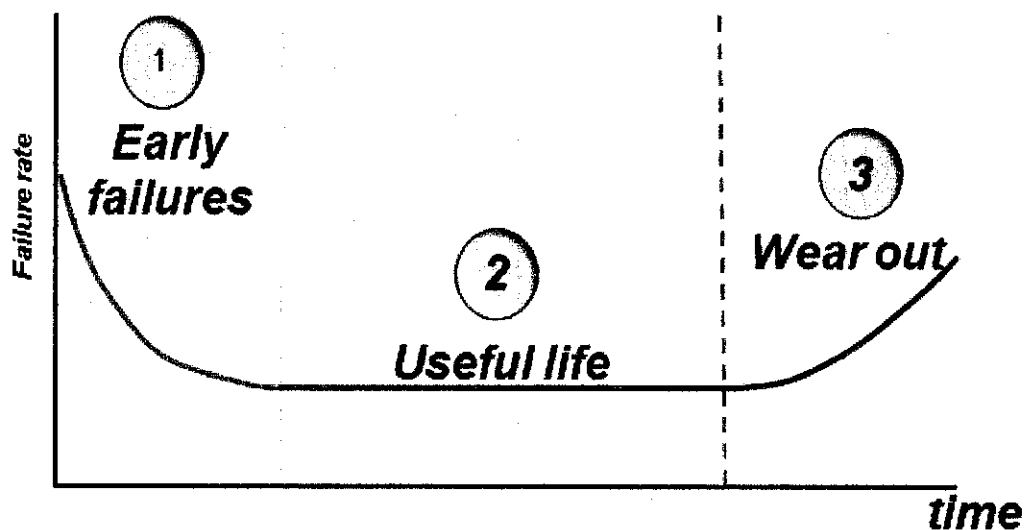

Figure 2.3: Bathtub Curve (Operations Management Notes, UTP, 2011)

1. Early failures also known as infant mortality or burn-in period:
Failure rate is initially higher due to issues such as improper manufacturing, installation and poor materials

2. Useful life: Failure rate is approximately constant. This flat-portion of bathtub is also referred as component's or system's 'normal operating life' where realistically many components or systems spend most of their lifetimes operating
3. Wear out: Increasing failure rate because of degradation phenomena due to wear out. Wear out is generally caused by fatigue, corrosion, creep, friction and other aging factors

Heizer and Render (2011) also stated that there are four important tactics for improving the reliability and maintenance not only of products and equipment but also of the systems that produce them.

Reliability tactics

- Improving individual components
- Providing redundancy

Maintenance tactics

- Implementing or improving preventive maintenance
- Increasing repair capabilities or speed

For this project, the author will focus on improving individual components and providing redundancy if applicable. The analysis will look into what happen to the system reliability if the tactics is being implemented.

Availability means the duration of up-time for the operation. Davidson (1998) stated that there are three factors that will increase the availability.

- Increase the time to failure
- Decreasing down-time due to repair or scheduled maintenance
- Accomplishing the above two in a cost-effective manner

For further understanding on the availability analysis, the author has referred to a journal to make it as the main reference and guideline throughout the research. The journal is availability analysis of gas turbine used in power plants by Carazas et al. (2009). Gas turbine is considered as a complex system. The availability analysis is related with its parts' reliability. Carazas et al. (2009) also mention that maintenance policy not only influence on the parts' repair time but also on the part's reliability that will affect the system degradation and availability as a whole.

Carazas et al. (2009) stated that reliability can be defined as the probability that a system will perform properly for a specified period of time under a given set of operating conditions

The method that has been used is based on the system reliability concepts such as functional tree development, application of failure mode and effects analysis to identify critical components for improvement of system reliability, and reliability and maintainability evaluation based on a historical failure database.

The first step towards the analysis is to create a functional tree. In this functional tree, there will be functional links between the equipment subsystems. From here, the relationship between each component in gas turbine can be seen. Although two systems have the same subsystem there might be differences in term of the technologies used by the manufacturer. So it is necessary to develop specific functional tree for each system. The next step will be the Failure Mode and Effects Analysis (FMEA) for the system in order to define the most critical component in the system.

The third step is known as reliability analysis based on the time to failure data that has been collected throughout the system operation. The data should be base on each subsystem in the system. The reliability of the subsystem then is calculated based on the data. Next after the calculation has been done, the system reliability can be simulated by using a block diagram. The system availability can be evaluated using the block diagram.

For a system, an unexpected component failure will increase the cost. The costs due to the failure are included maintenance, corrective cost and system unavailability cost. System unavailability cost came from the lost of production (profit) that occur when the system is not operating. Carazas et al. (2009) said that “The reliability block diagram analysis allows the prediction of a possible availability improvement considering the application of new maintenance procedures, expressed by the reduction of corrective maintenance repair time”.

Parameter that commonly used in the reliability analysis, Mean Time To Failure

$$MTTF = \int_0^{\infty} R(t) dt$$

Where:

$R(t)$ = reliability at time t

T = time period [h]

The Weibull distribution parameter is widely used in the reliability calculation.

$$R(t) = e^{-\left(\frac{t}{\eta}\right)^{\beta}}$$

Where:

$R(t)$ = reliability at time t

t = time period [h]

β = Weibull distribution shape parameter

η = Weibull distribution characteristic life [h]

The software Weibull++ is being used to get the Weibull distribution parameter. By using Weibull++, lognormal distribution parameters for maintainability modeling also can be assessed.

Maintanability

$$M(t) = \Phi \frac{\ln t - \mu}{\sigma}$$

Where:

- $M(t)$ = maintainability at time t
- μ = lognormal distribution mean value
- σ = lognormal distribution standard deviation
- Φ = standard normal distribution cumulative function

Carazas et al. (2009) then used Monte Carlo simulation method so that the availability can be estimated for an operation time. Refer to Figure 2.4 to see the overall method that being used by Carazas et al. (2009).

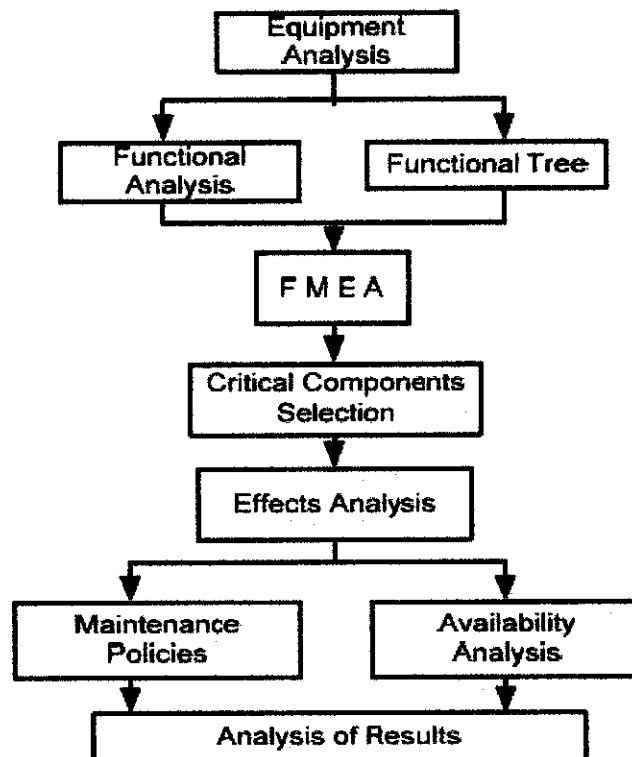

Figure 2.4: Flowchart for System Availability Evaluation (Carazas et al. 2009)

2.5. Reliability Block Diagram

RBD is a graphical representation of the relationship between components in a system. RBD is to perform system reliability and availability analysis of the system. It is represented by a block diagram and consisting series and parallel networks. A block may represent a component or subsystem. The system reliability will be influenced by each block's reliability. Dhillon and Yang (1997) mention that, primary advantage of using RBD is easy to understand and apply. However it is not suitable for degraded states of components and system. For such condition, Markov method is preferable. In general, RBD and Markov will produce similar result.

For the project, the author will use Block-sim software to build and evaluate the reliability of the systems. The software is easier to build the RBD and can easily add block diagram to see the effect of redundancy.

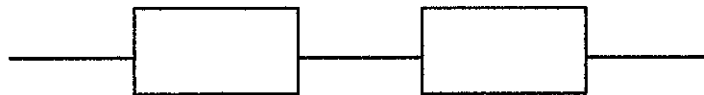

Figure 2.5: Series System

Figure 2.5 represents a series system. In a series system, if one component is fail, then the entire system will be consider as fail. In other words, all components in a system must be function well for the system to succeed

To compute the reliability of a series system is easy. It is simply finding the product of individual blocks.

$$R_s = R_1 \times R_2 \times R_3 \times \dots \times R_n$$

Where R_1 = reliability for component 1

R_2 = reliability for component 2

However, a series system is not too preferable as the number of component in the system increases, the reliability of the system will be decreased. In other words, even all the component in the system is having 99% of reliability, but there are 100 components in the system, the system reliability will be around 37%.

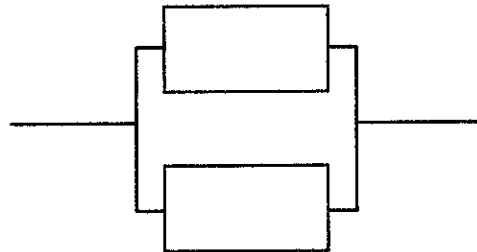

Figure 2.6: Parallel System

Figure 2.6 represents a parallel system. In a parallel system, if one component fails, the system still can continue to work as usual. This is due to 'back up' component that will be on standby mode. In the event of failure, the standby component will be started to operate. This is the common tactics that being used by the plant management to ensure the plant will be continuously produce the output.

$$1 - [(1-R_1) \times (1-R_2) \times \dots \times (1-R_n)]$$

Where R_1 = reliability for component 1

R_2 = reliability for component 2

3. METHODOLOGY

Reliability, Availability and Maintainability (RAM) modeling actually involve a lot of calculation. Having adequate and accurate data and information is essential for RAM engineering. There will be no lab work or fabricating product. It consists of analysis involves with data, formula and using software.

The software that will be going to use are:-

- Weibull ++
- Block-sim

The project will be conducted in two semesters, 14 weeks for each semester. For the 1st semester, the author is focusing on the understanding on the Dehydration Unit and RAM modeling. At the same time, the author will learn and understand on how to use the above mentioned software. The author has seeking assistant from the supervisor and Mr. Messeret, a graduated assistance for more understanding in using the software.

For the 2nd semester, the author has started to develop the RBD of dehydration unit. Since in the dehydration unit consist a subsystem known as regeneration system, so the author has come out with two RBD. This RBD has been verified with the expert. The author is expected to receive the data from PETRONAS Gas Berhad. However, due to some problem and delayed, the data cannot be received within the timeline of the project. So the author used data from OREDA.

3.1. Research Methodology

- Preliminary research
 - Dehydration - the function, components and process flow of DHU.
 - RAM – Study on reliability. Focus more into the RBD
- Data collection
 - The data is expected to be received in term of failure rate, MTBF,MTTR for DHU system
 - If there are delayed with PETRONAS Gas Berhad, then the data will be based on the oreda
- Identify the relationship for each component in DHU (parallel or serial)
- Construct functional block diagram of DHU.
- Analyze data. Calculation based on formula and using Weibull++ to develop required distribution.
- Construction of RBD
 - Using the Block-sim software
- Verify RBD model with expert
- Data input for RBD based on the data and calculation that being made before
- RBD simulation
- Verify the result of simulation with expert.
- Result analysis and discussion
- Report writing.

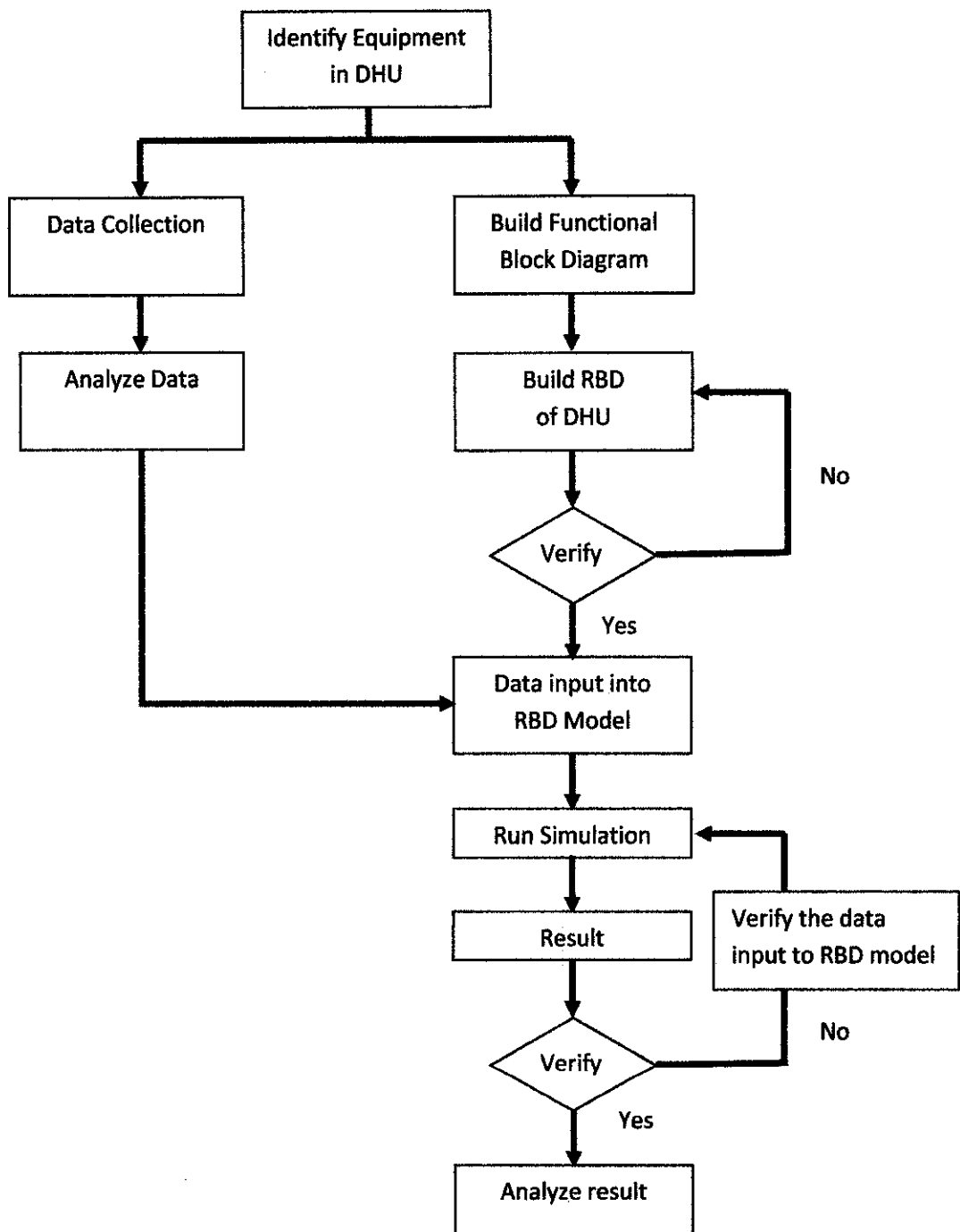

Figure 3.1: Research Methodology Flowchart

Based on the Figure 3.1, there are two routes toward the final result. The 1st route is about data collection and the data analysis, while the other one is about developing the RBD.

3.2. Data Analysis

There are a few step need to be done to analyze data. Figure 3.2 shown the step involve in analyze the data. This step is planned to be used if the real data received from the PGB. However since the author has used the data from OREDA, the Figure 6 step can be skipped. The OREDA will be discussed in the result and discussion section.

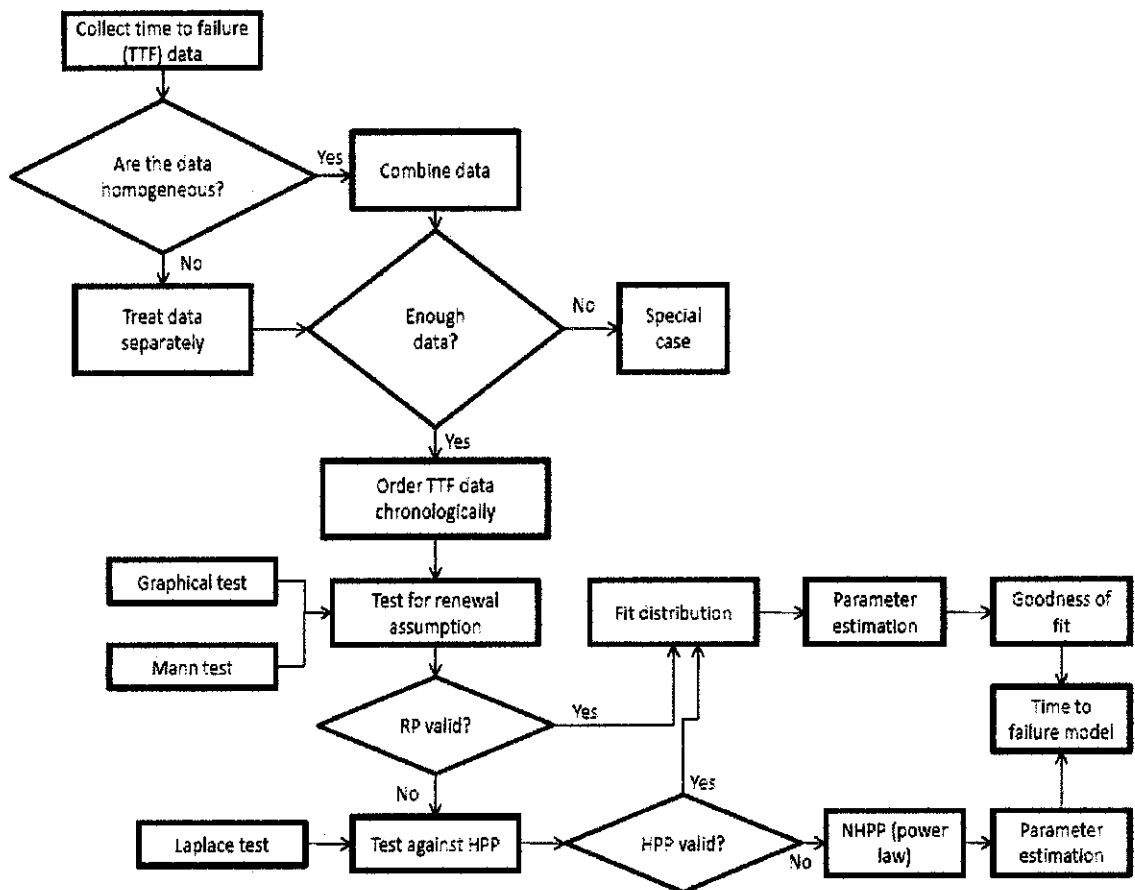

Figure 3.2: Data Analyze Flowchart

3.2.1. Time to Failure Model

Failure data are required to develop forecasting models to be used in reliability assessment. The models are important for showing the characteristic of distribution including the median, mean or extreme value. Different distribution or model can provides different information of the data of the equipment.

3.2.2. Homogeneous Data

It is very important to decide whether the data is homogeneous or not before proceed to next analysis. If an equipment is highly correlated the other (same type) of equipment, the reliability can be observe as a whole. For example, if two pumps have homogeneous data, the data can be combined and analyze together. This will simplify the study and time efficient. However, if the opposite occur, the data needed to be treated separately and more time consuming. Obtaining a perfect homogeneous data is almost impossible

3.2.3. Laplace Test

Laplace Test is important in determining the reliability of a system. The Laplace test is being used to validate the use the constant failure rate (exponential) model. This is crucial because the variable of the interest system is not the lifetime of the system but the times of successive failures of a single system.

3.2.4. Mann Test

The Mann Whitney U test is a nonparametric test that compares two uncorrelated samples. This test can be used to determine the differences such as performance and result between the two samples taken before and after an improvement has been done.

3.2.5. Graphical Test

Based on ReliaSoft Corporation,

Graphical test is the simplest method for obtaining results in both life data and accelerated life testing analyses. The graphical method for estimating the parameters of accelerated life data involves generating two types of plots. First, the life data at each individual stress level are plotted on a probability paper appropriate to the assumed life distribution (i.e. Weibull, exponential, or lognormal). The parameters of the distribution at each stress level are then estimated from the plot. Once these parameters have been estimated at each stress level, the second plot is created on a paper that linearizes the assumed life-stress relationship (i.e. Arrhenius, inverse power law, etc.). The parameters of the life-stress relationship are then estimated from the second plot. The life distribution and life-stress relationship are then combined to provide a single model that describes the accelerated life data.

The Laplace test, Graphical test and Mann test is to verify whether the data taken from the plant is valid or not.

3.3. Reliability Block Diagram

In order to build a RBD, first need to be sure on how the equipment in DHU related together. For this project, only active, critical and main equipment will be considered. Based on Pareto principle, the 80% of effect is due to 20% of causes. So with identifying and improving the (small number) critical equipment might improve the productivity a lot as a whole system. The passive or non-critical component that will not be included is such as pipe, tank, some of valve, and some of the filter (based on their function). Most of the valve is negligible due to less effect to the system in term of reliability and assume that they are very unlikely to fail. Example for important equipment is heat exchanger, mercury removal, gas turbine and compressor.

To construct the RBD, the author began with referring the P&ID and DHU flowchart that received from PGB. This will give the author information of equipment and their function in the DHU. Figure 3.3 showed the diagram of DHU that the author refers to build the 1st draft of RBD. The 1st draft diagram then sent to expert to be verified and adjusted.

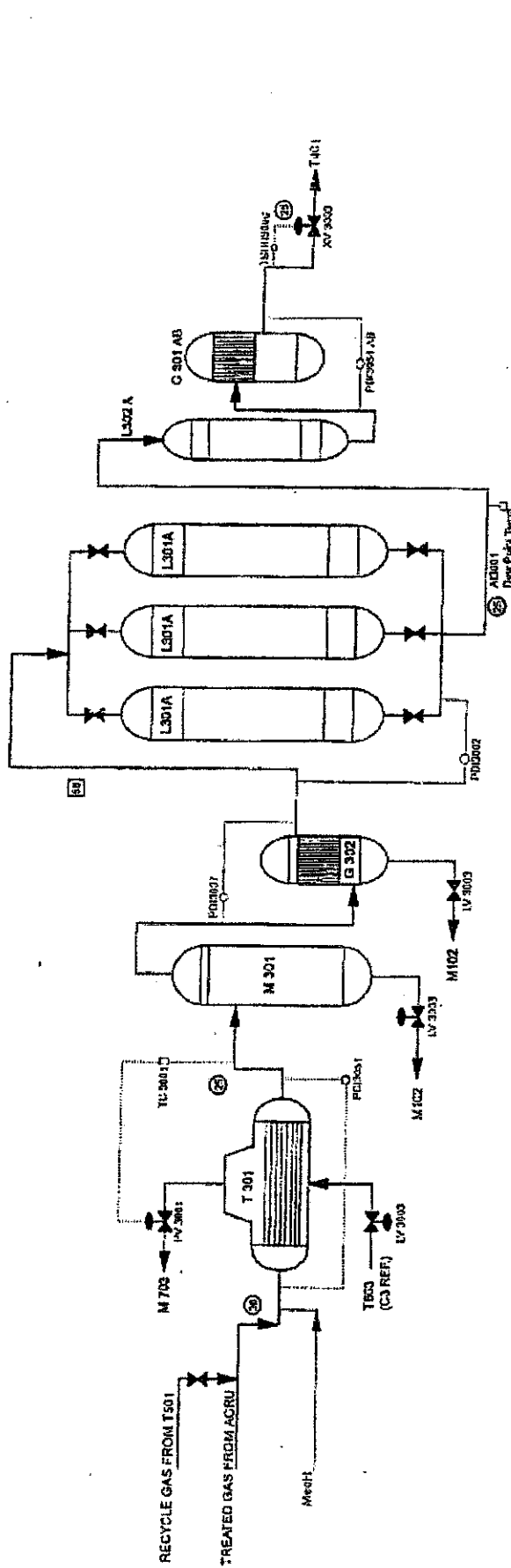

LEGEND
 □ : Pressure in barg
 ○ : Temperature in deg C
 G 301A/B : Mercury Removal Filter
 G 302 : Dryer Inlet Filter Separator
 L 301A/B/C : Feed Gas Dryer
 M 301 : Dryer Inlet Knock Out Drum
 T 301 : Dehydration Inlet Chiller

Figure 3.3: DDU Diagram (PGB, 2011)

The table showed the main equipments in the DHU and their function.

Equipment	Description
T-301 Dehydration inlet chiller	Shell and tube kettle type HE Decrease gas temperature until most of the vapor in gas feed is condensed and remain above hydrate formation temperature
M-301 Dryer inlet K.O drum	Separate liquid (water and condensed hydrocarbon) from the gas then sent to the Decanter drum M-102 Gas sent to G-302
G-302 Filter separator	Filter the liquid droplets that larger than one micron (sent to M-102)
L-301A/B/C Feed gas dryer	Remove water vapor by using molecular sieve beds Two in service, one in standby
L-302A/B Feed gas mercury removal beds	Remove mercury Operated on parallel service with no-standby
G-301A/B Mercury removal	Further removal. Remove any dust or solid particles One in service, one in standby Gas sent to LTSU
XV-3003	Shut off valve

3.4. Software

3.4.1. Block-sim

The block-sim software is used to draw RBD diagram. After the drawing has done, the calculation in finding system reliability can be made by using the same software. Besides that, a various type of graph can be generated to assist in analysis.

The author begins the analysis by using static reliability. In static reliability, the reliability of each component will be assumed and the factor of time is being neglected.

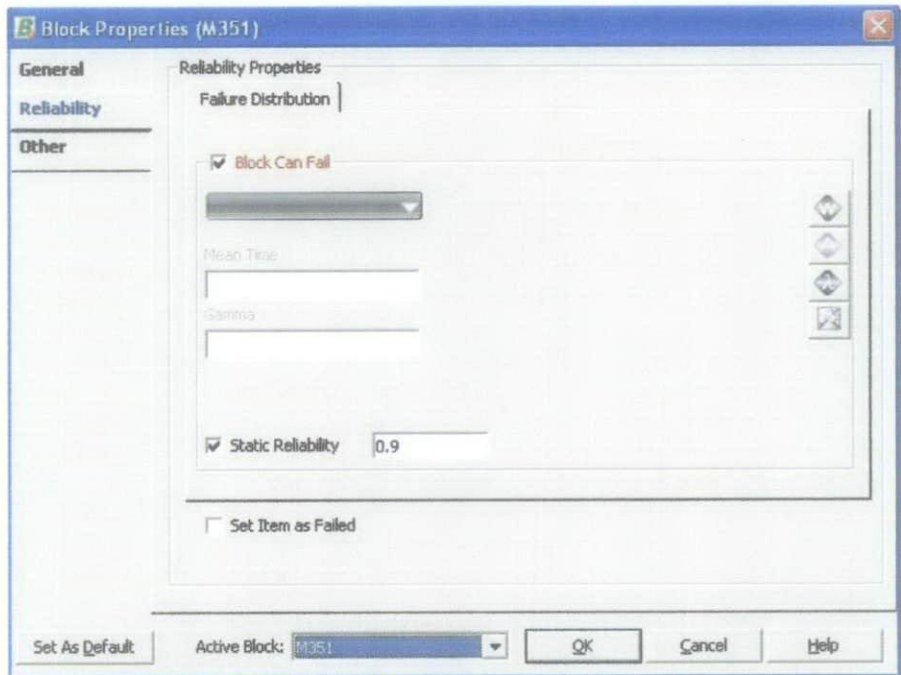

Figure 3.4: Input data for static reliability

Next, the author used data from OREDA Handbook. Since the data is followed the exponential distribution, the author select the exponential distribution in the Block-sim software

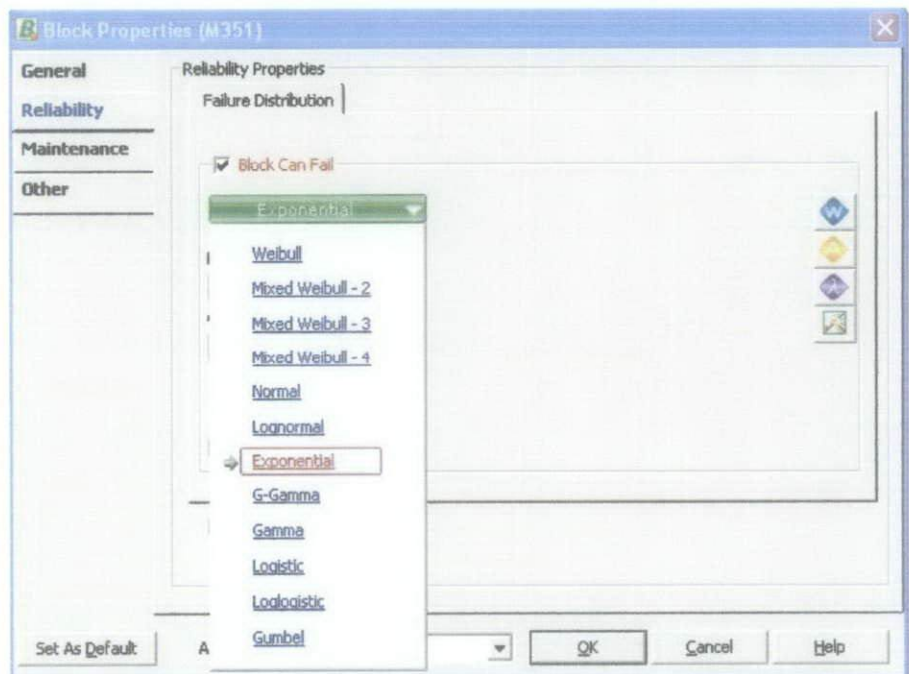

Figure 3.5: Selecting exponential distribution in Block-sim

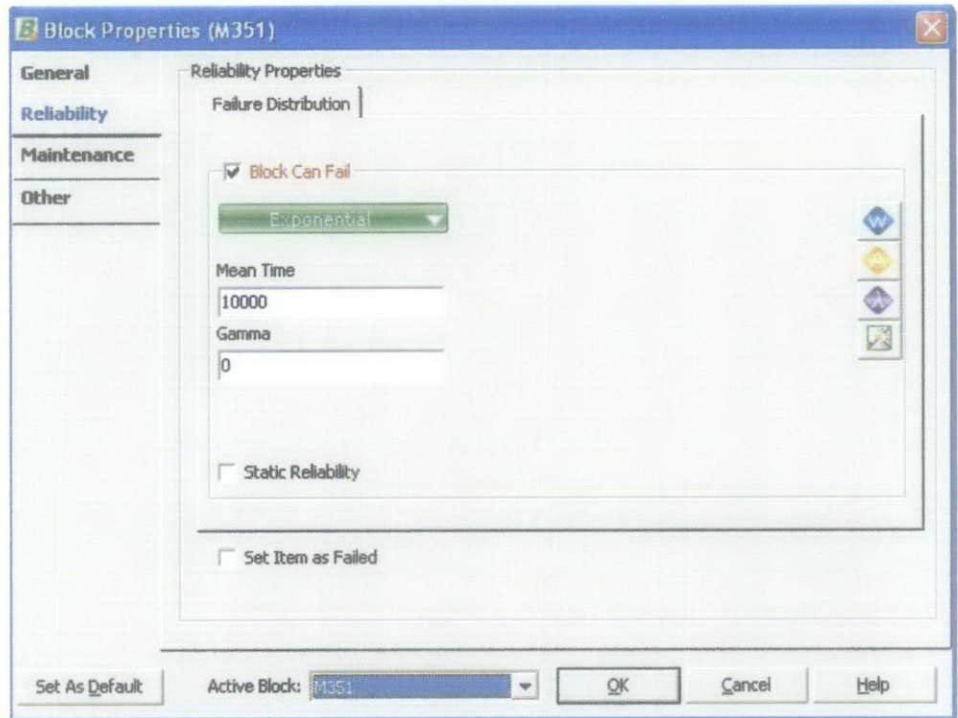

Figure 3.6: Input data for exponential distribution

The failure rate from OREDA will be entered at the mean time blank.

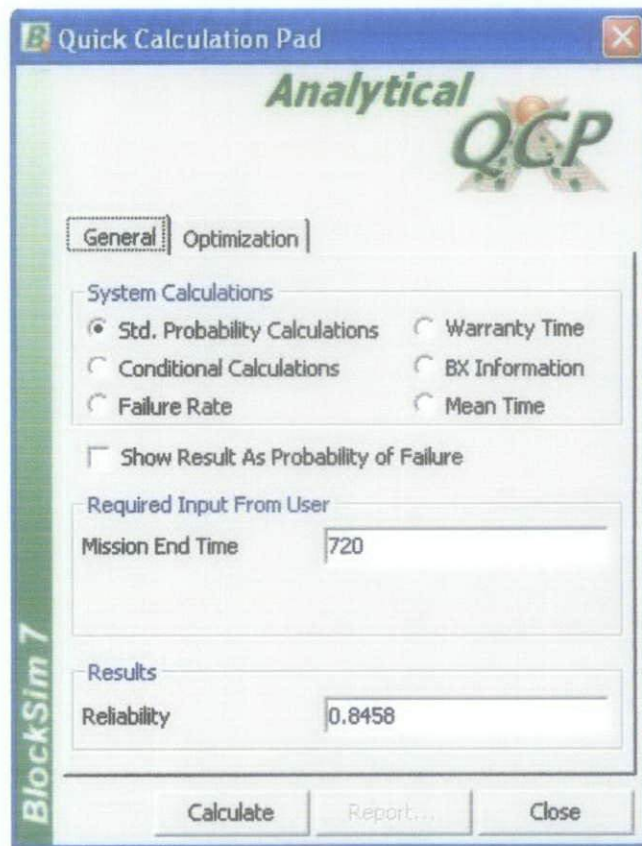

Figure 3.7: Computing the reliability

Then the system reliability at specific time (mission end time) can be calculated. For example, 720 hours will represent one month and 8760 will represent one year. Every component's reliability also can be known by seeing the report of calculation.

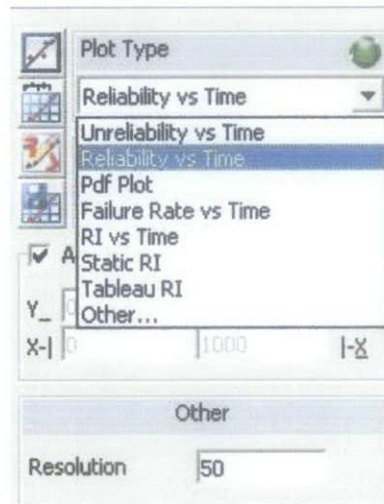

Figure 3.8: Generating graph

In addition, several of graphs can be generated by the Block-sim software to assist in the analysis.

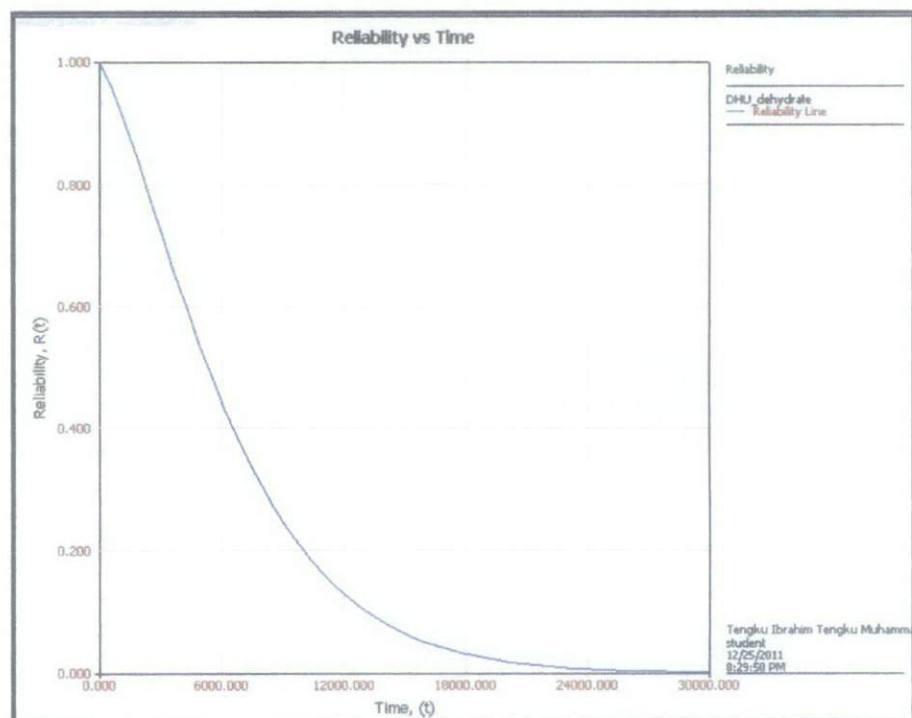

Figure 3.9: Sample of graph

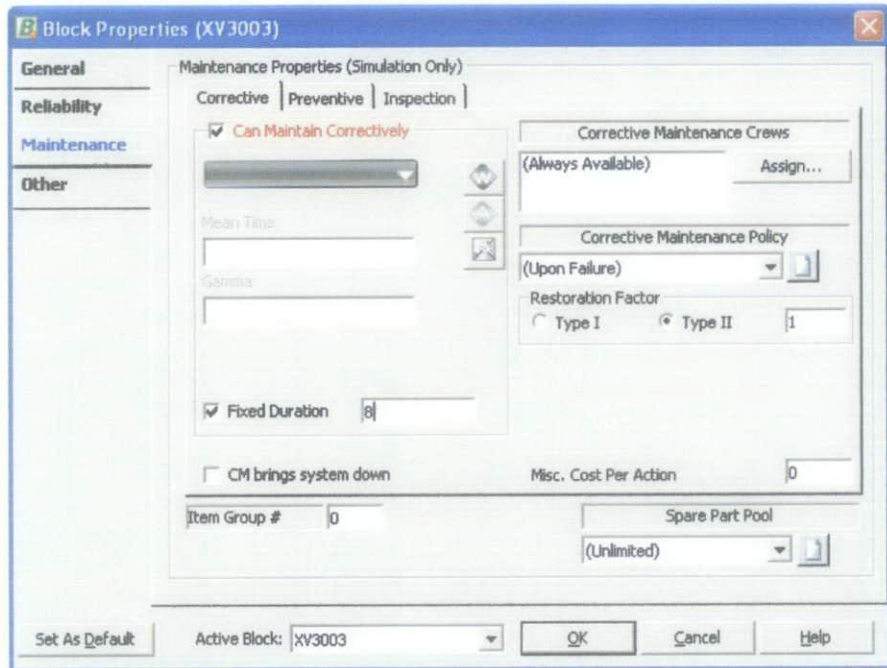

Figure 3.10: Input data for corrective maintenance

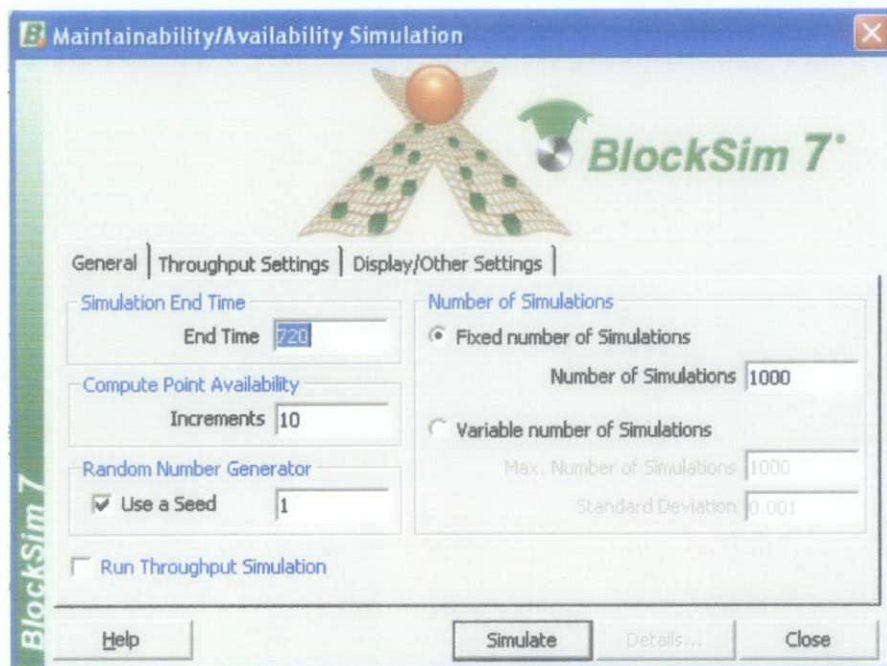

Figure 3.11: Maintainability/Availability simulation

3.4.2. Weibull++

The use of this software is depended on the type of data that are being used. Basically, the Weibull++ will be used to determine some parameter that then will be used in the Block-sim software. So if the data received already can be used straight away in the Block-sim, the Weibull++ will not used

3.5. Timelines for FYP 1

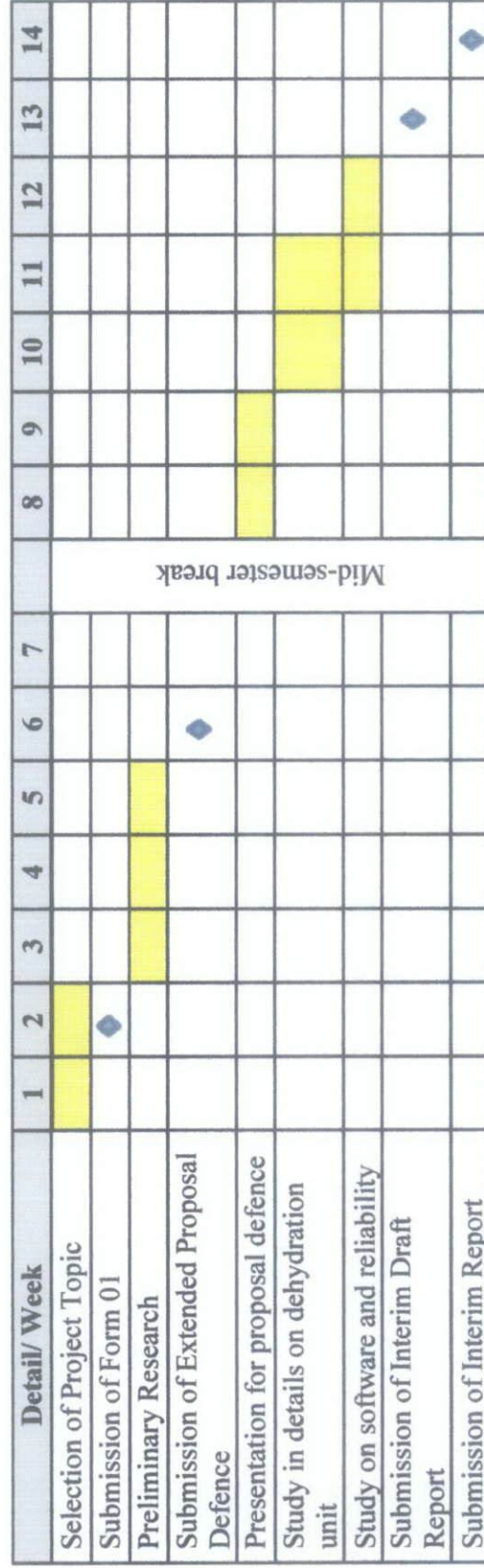

Figure 3.10: Gantt chart for FYP 1

3.6. Timelines for FYP 2

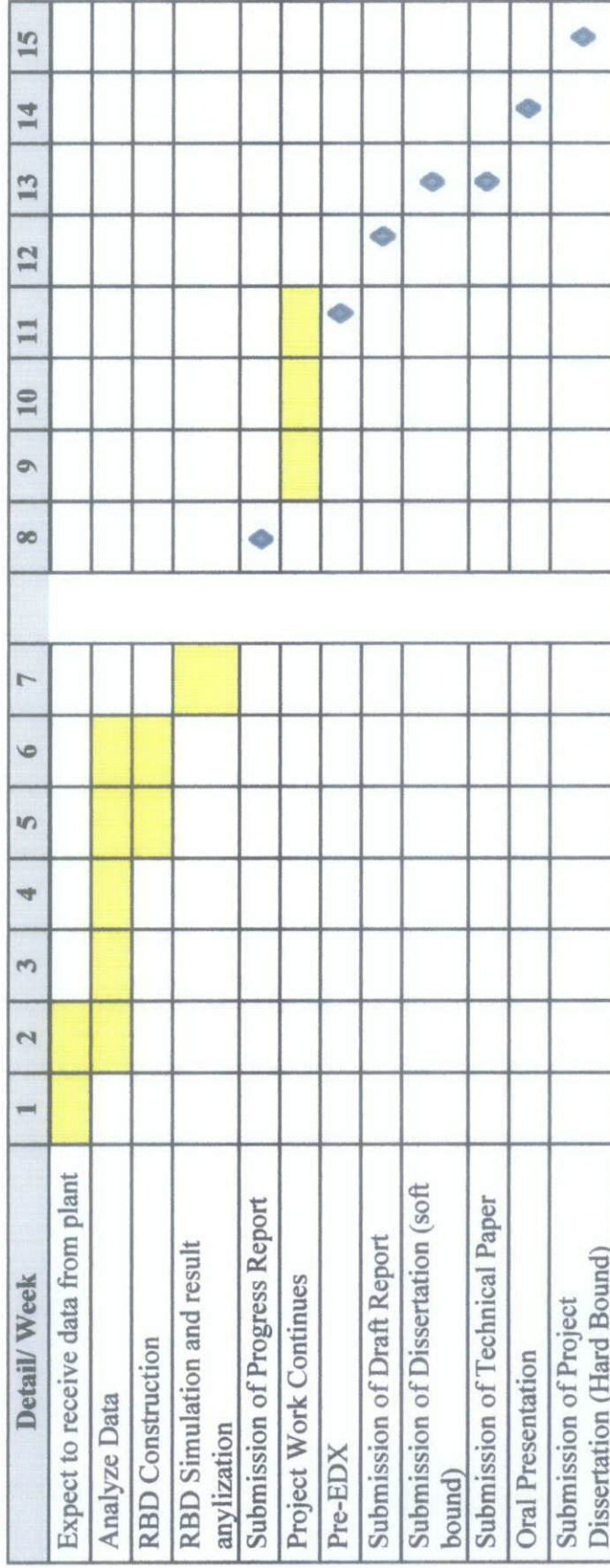

Figure 3.11: Gantt chart for FYP 2

4. RESULT AND DISCUSSION

4.1. Reliability Block Diagram

In developing the RBD, the most important this need to be done is to identify all important equipment in the DHU. The other equipment such as pump, valve, motor and pipe is being ignored to simplify the studies. The 1st draft of RBD is being draw by using Microsoft Word. It is not the finalize RBD and expected to have weakness and adjustment is needed. This is due to lack of knowledge and information of author on how the real DHU in PGB works. The author just draws the RBD by using the DHU diagram and does not sure which component is critical. The author has send the 1st draft of RBD (refer to Figure 4.1) to the engineer in PGB to verify.

After a while, the author received the RBD that has been verified by the engineer. For the DHU diagram, there has been some adjustment. Refer to Figure 4.2. The G-302, filter separator has been removed from the diagram. The filter is assumed to be not critical compared to the other equipment. Hence the filter will not be considered for this project. Another thing that has been added is the regeneration system. Since the regeneration system is a subsystem in the DHU, another RBD has been developed for the regeneration system. Figure 4.3 represent the RBD for the regeneration.

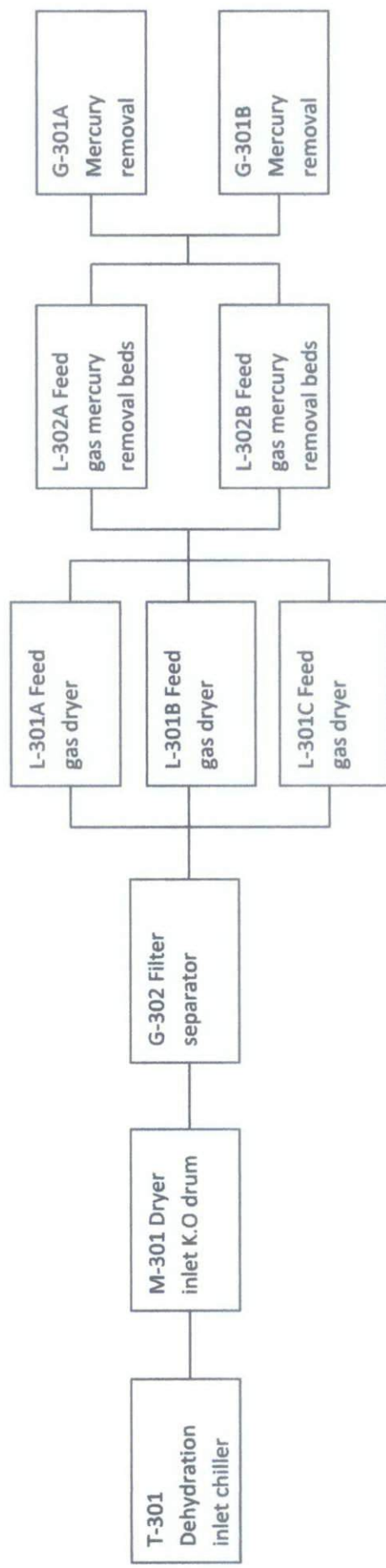

Figure 4.1: First draft of RBD

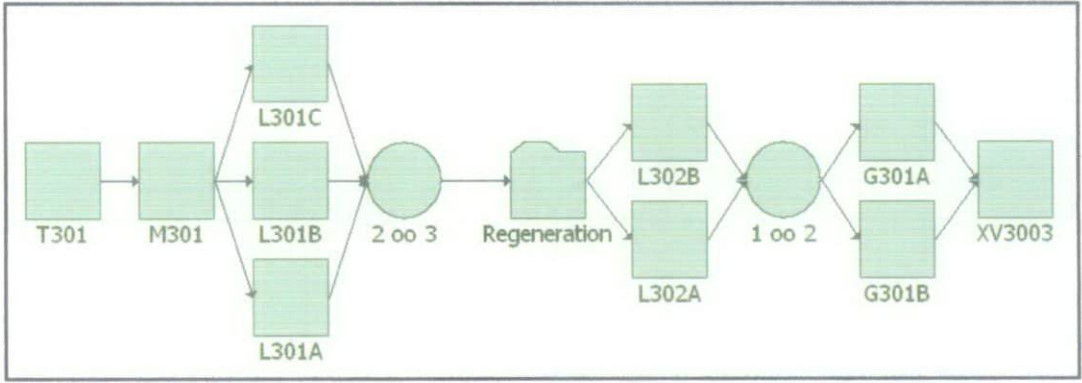

Figure 4.2: RBD for DHU

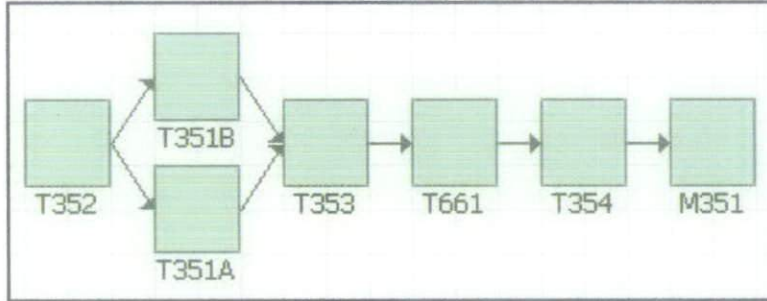

Figure 4.3: RBD for Regeneration system

4.2. Static Reliability

Reliability of a system that being evaluated without considers the time factor is known as static reliability. This type of reliability is usually being used as a form of preliminary analysis. The reliability of each component in the RBD is estimated or assumed to calculate the reliability of whole system. For static reliability, the component reliability does not vary with time. It is assume that the component fail independently.

4.2.1. Static reliability data

First of all, each component in the RBD is assumed as 0.9. Next the system reliability will be calculated by using Block-sim software. Table 4.1 is example by assume all component 0.9 by using regeneration RBD.

Table 4.1: Static reliability data

Block	Reliability	Prob. of Failure
M351	0.9	0.1
T351A	0.9	0.1
T351B	0.9	0.1
T352	0.9	0.1
T353	0.9	0.1
T354	0.9	0.1
T661	0.9	0.1

By using this assumption, the reliability of whole system is 0.5846

4.2.2. Static reliability result

Table 4.2: Static reliability result

Diagram	Reliability of Each Component	Probability of Failure	System Reliability
DHU	0.9	0.1	0.625
	0.92	0.08	0.6944
	0.94	0.06	0.7671
	0.96	0.04	0.8427
	0.98	0.02	0.9205
Regeneration	0.9	0.1	0.5846
	0.92	0.08	0.6549
	0.94	0.06	0.7313
	0.96	0.04	0.8141
	0.98	0.02	0.9036

4.2.3. What-if Analysis for static reliability

What-if analysis is to check which equipment will give high impact on system reliability if the reliability of that equipment is improved. If that kind of equipment is identified, so the plant can focus more on improving the reliability of that equipment rather to focus on all equipment.

For what-if analysis, the author assume all equipment have static reliability of 0.9 where the system reliability for that will be 0.625 (DHU) and 0.5846 (regeneration). Next, one of the equipment will be improve to 0.96 while the other will maintain at 0.9. The system reliability will be calculated. This will be repeated with change the other equipment to 0.96 and maintain the rest of them at 0.9. The result of this analysis is showed at table 4.3 and table 4.4.

Table 4.3: what-if analysis result for DHU

Block	Previous Reliability	Improved Reliability	System Reliability
Regeneration	0.9	0.96	0.6667
M301	0.9	0.96	0.6667
L302B	0.9	0.96	0.6288
L302A	0.9	0.96	0.6288
L301C	0.9	0.96	0.632
L301B	0.9	0.96	0.632
L301A	0.9	0.96	0.632
G301B	0.9	0.96	0.6288
G301A	0.9	0.96	0.6288
XV3003	0.9	0.96	0.6667
T301	0.9	0.96	0.6667

Table 4.4: what-if analysis result for regeneration system

Block	Previous Reliability	Improved Reliability	System Reliability
T351A	0.9	0.96	0.5881
T351B	0.9	0.96	0.5881
T353	0.9	0.96	0.6236
T354	0.9	0.96	0.6236
T661	0.9	0.96	0.6236
M351	0.9	0.96	0.6236
T352	0.9	0.96	0.6236

Based on what-if analysis, the author found out that by improving the reliability of any component in series will have higher impact on the system reliability. By improving the parallel component also will improve the system efficiency however, the impact will not be greater than component in series.

The early conclusion that can be made is that the plant should focus more on improving and maintaining the series equipment rather on the parallel equipment. However, this analysis does not give the clear result as this analysis is neglected the time factor, place or condition of the plant. The plant can't make a decision just only based on the static reliability. If the real data being used, there might some changing in the result and conclusion

The author should receive the data from the PGB. However there is a problem in data collection at the PGB and will not make it in time within the project time line. To continue the project, the author with the advice of supervisor conducts further analysis by using data from OREDA.

4.3. OREDA

OREDA (Offshore Reliability Data) is a data collection programme that has been started since early eighties. Based on Langseth et al. (1998) the reliability data has been collected for 24,000 offshore equipment units comprising approximately 33,000 failures. The project is supported by ten oil companies; AGIP, BP, Elf, Esso, Norsk Hydro, SAGA, Shell, Statoil, and Total.

Langseth et al. (1998) continued that the participating oil companies usually use the data in the development of new oil fields and improving existing facility operation. The reliability data are typically used as input to safety and reliability analysis.

The benefits are:

- Safer operations,
- Increased production availability,
- Optimized maintenance.
- key factors in choosing cost-effective solutions

The data collected in the OREDA handbook basically follow exponential distribution. Exponential distribution means that the equipment will have constant failure rate.

The OREDA database has been classified into four categories. Based on the OREDA handbook, the categories are:-

- **Critical failure:** A failure which causes immediate and complete loss of an equipment unit's capability of providing its input
- **Degraded failure:** A failure which is not critical but it prevents an equipment unit from providing its output within specifications. Such a failure would usually but not necessarily be gradual or partial and may develop into a critical failure in time
- **Incipient failure:** A failure which does not immediately cause loss of a unit's capability of providing its output but if not attended to, could result in critical or degraded failure in near future
- **Unknown:** Failure severity was not recorded or could be deduced.

The degraded, incipient and unknown failures are being categorized as non-critical failure.

4.3.1. OREDA data

For data collection, the author has referred to OREDA handbook 1984 and 2009. The OREDA data can be referred to the appendices. From the data, the author chooses to prioritize the data from critical failures category. If there are no data in critical category, the priority will follow, degraded, incipient then the unknown failures. By definition, the critical failure will cause complete loss to the equipment. As a result of that, it is important to consider the critical failure first before continue to the non-critical failure.

Actually, not all equipment in the DHU or regeneration system can be found in the OREDA. Due to that, the author seeks advice from the supervisor and expert. Referring to their opinion and used engineering judgment, the data will be chosen based on the similarity of the structure, characteristic and function of the equipment.

From the OREDA, the MTTF of each equipment will be calculated.

$$MTTF = \frac{1}{\lambda}$$

λ = constant failure rate, in failures per unit of measurement. (Failure rates per hour)

Table 4.5 showed the data that being collected by referring to the OREDA.

Table 4.5: Data collection (mean failure rate)

Code	Name	MTTF	Remarks
T-301	Dehydration inlet chiller	83857.44235	critical
M-301	Dryer inlet K.O drum	833333.3333	critical
L-301A	Feed gas dryer	14888.70692	incipient
L-301B	Feed gas dryer	14888.70692	incipient
L-301C	Feed gas dryer	14888.70692	incipient
L-302A	Feed gas mercury removal beds	14888.70692	incipient
L-302B	Feed gas mercury removal beds	14888.70692	incipient
G-301A	Mercury removal	83333.33333	critical
G-301B	Mercury removal	83333.33333	critical
XV-3003	Shut off valve	277777.7778	critical
T-352	Heat exchanger	83857.44235	critical
T-351A	Heat exchanger	83857.44235	critical
T-351B	Heat exchanger	83857.44235	critical
T-353	Heat exchanger	83857.44235	critical
T-661	Heat exchanger	83857.44235	critical
T-354	Heat exchanger	83857.44235	critical
M-351	Knock out drum	833333.3333	critical

After all data has been collected, the data will be used in the Block-sim software to calculate the reliability for each equipment and the system reliability. Table 4.6 showed the result of reliability with respect of 720 hours (1 month). Please refer to appendices to observe the reliability over time.

Table 4.6: Result for calculation (mean failure rate)

Diagram	Code	Reliability	System Reliability
Regeneration	T-352	0.9915	0.9653
	T-351A	0.9915	
	T-351B	0.9915	
	T-353	0.9915	
	T-661	0.9915	
	T-354	0.9915	
	M-351	0.9991	
DHU	T-301	0.9915	0.9454
	M-301	0.9991	
	L-301A	0.9528	
	L-301B	0.9528	
	L-301C	0.9528	
	L-301A	0.9528	
	L-302B	0.9528	
	G-301A	0.9914	
	G-301B	0.9914	
	XV-3003	0.9974	
	Regeneration	0.9653	

Based on the table, reliability for all system is above 0.9 and almost reached 1 (perfect reliability, without any failure). Since most of the data is referred to critical category, it can be said that the probability the equipment to fail due to critical failure is very low. Hence the system reliability is very high. So at the 720 hours, the system reliability is still good.

For the above analysis, the author calculated based on mean (average) failure rate. Now the author used the upper failure rate in OREDA. The upper failure rate mean that the highest probability that the equipment will fail due to the specific category.

Table 4.7: Data collection (upper failure rate)

Diagram	Code	Name	MTTF	Remarks
DHU	T-301	Dehydration inlet chiller	17677.21	critical
	M-301	Dryer inlet K.O drum	243902.4	critical
	L-301A	Feed gas dryer	7925.814	incipient
	L-301B	Feed gas dryer	7925.814	incipient
	L-301C	Feed gas dryer	7925.814	incipient
	L-301A	Feed gas mercury removal beds	7925.814	incipient
	L-302B	Feed gas mercury removal beds	7925.814	incipient
	G-301A	Mercury removal	41666.67	critical
	G-301B	Mercury removal	41666.67	critical
	XV-3003	Shut off valve	65595.28	critical
Regeneration	T-352	Heat exchanger	17677.21	critical
	T-351A	Heat exchanger	17677.21	critical
	T-351B	Heat exchanger	17677.21	critical
	T-661	Heat exchanger	17677.21	critical
	T-354	Heat exchanger	17677.21	critical
	M-351	Knock out drum	243902.4	critical

Table 4.8: Result for the calculation (Upper failure rate)

Diagram	Code	Reliability	System Reliability
Regeneration	T-352	0.9601	0.8458
	T-351A	0.9601	
	T-351B	0.9601	
	T-353	0.9601	
	T-661	0.9601	
	T-354	0.9601	
	M-351	0.9971	
DHU	T-301	0.9601	0.7776
	M-301	0.9971	
	L-301A	0.9132	
	L-301B	0.9132	
	L-301C	0.9132	
	L-301A	0.9132	
	L-302B	0.9132	
	G-301A	0.9829	
	G-301B	0.9829	
	XV-3003	0.9891	
	Regeneration	0.8458	

Based on the table, after 720 hours, the reliability for all system is lower 0.9 and lower than the previous calculation. By using the upper value, DHU reliability is lower than the regeneration. However, the lowers reliability component in DHU is the regeneration system. Please refer to appendices to observe reliability over time.

The reliability of equipment in regeneration is already almost 1. So the authors try to focus in improving the equipment in the DHU. As the result above, the lowest reliability value is 0.9132. There is a number of equipment that has the value. To do redundant is one of the solutions to improve the equipment reliability. However, for this project, it is unwise to do redundant to all lower reliability value equipment. In fact, redundancy for one equipment is already expensive.

4.3.2. What-if analysis for OREDA (Upper failure rate at 720 hours)

Now the author tries to increase the reliability of L-301A/B/C and L-302A/B. The author increases the MTTF of respective equipments to 16000 hours (increasing 100% from previous MTTF) to see how it will affect the system reliability.

Table 4.9: Increasing the reliability

Block	Reliability	Prob. of Failure
1 oo 2	1	0
2 oo 3	1	0
Regeneration	0.8458	0.1542
XV3003	0.9891	0.0109
G301B	0.9829	0.0171
G301A	0.9829	0.0171
M301	0.9971	0.0029
T301	0.9601	0.0399
L301C	0.956	0.044
L301B	0.956	0.044
L301A	0.956	0.044
L302B	0.956	0.044
L302A	0.956	0.044

After increasing, those equipments reliability become to 0.956, the new system reliability is 0.7945. Based on analysis, the reliability of DHU has been increased by 0.0169. However the improvement is very small. Since the author is not using the actual data, the equipment like heat exchanger and dryer has been assumed to have same failure rate. So the result might not be accurate.

By using the Block-sim software, the author tries to optimize the reliability for the DHU (not include the regeneration system). Based on the calculation made, without improving the regeneration system, DHU just can be improved up to 0.84 even though all the equipment has been improved to almost 1. The result is showed in the table 4.10

Table 4.10: Optimizing DHU (excluding regeneration system)

Block Name	Reliability(720)	Goal(720)
T301	0.9601	0.9971
XV3003	0.9891	0.9983
M301	0.9971	0.999
L302B	0.9132	0.9888
L301A	0.9132	0.9937
G301A	0.9829	0.9942
L302A	0.9132	0.9888
L301C	0.9132	0.9937
G301B	0.9829	0.9942

Since the highest possible increment for the DHU is up to 0.84, now the author will include regeneration system to optimizing the DHU up to 0.84. Table 4.11 is the result of the calculation.

Table 4.11: Optimizing DHU (including regeneration system)

Block Name	Reliability(720)	Goal(720)
T301	0.9601	0.9601
XV3003	0.9891	0.9891
M301	0.9971	0.9971
L302B	0.9132	0.9132
L301A	0.9132	0.9132
G301A	0.9829	0.9829
Regeneration	0.8458	0.9138
L302A	0.9132	0.9132
L301C	0.9132	0.9132
G301B	0.9829	0.9829

Based on table above, to get 0.84 DHU reliability, just improved the regeneration system up to 0.9138 (without improving other equipment). Which mean that, the regeneration system has significant impacted towards DHU. Besides, this is occurred because the other equipment in DHU is already having high reliability compared to the regeneration system reliability. It is difficult to increase equipment that already has high reliability.

For regeneration system to achieve 0.9138, it is recommended by the Block-sim to improve the equipment (in the regeneration system) based on the table 4.12.

Table 4.12: Optimizing regeneration system

Block Name	Reliability(720)	Goal(720)
T661	0.9601	0.9788
T354	0.9601	0.9788
T353	0.9601	0.9788
T352	0.9601	0.9788
T351A	0.9601	0.9601
M351	0.9971	0.9971
T351B	0.9601	0.9601

Theoretically, adding redundancy will increase reliability. However, at the same time, it will increase the support requirement and costs. Besides the cost increase due to the need to buy the adding component, the additional cost also come from an increase in the total failures within the system. Based on the Department of the Army U. S. A (2007), “if nothing is done to improve the reliability of the individual components in a system, but additional components are added to provide redundancy, the total failure rate of the components will increase. System reliability will improve but more component failures will occur”. In conclusion, the redundancy is not always the best option for improving a system.

4.3.3. Maintainability / Availability

The analysis is continued by entering the repair time in maintainability. The maintenance duration is assumed as fixed and taken from OREDA. The data is as in table 4.13.

Table 4.13: Repair (manhours)

Diagram	Code	Repair (manhours)
Regeneration	T-352	1.5
	T-351A	1.5
	T-351B	1.5
	T-353	1.5
	T-661	1.5
	T-354	1.5
	M-351	3000
DHU	T-301	1.5
	M-301	3000
	L-301A	10
	L-301B	10
	L-301C	10
	L-301A	10
	L-302B	10
	G-301A	11
	G-301B	11
	XV-3003	8

The author wants to analyze the effect of corrective maintenance to the system. The result is in the table 4.14

Table 4.14: System overview

	No maintenance	With maintenance (original)	With maintenance (double)
Availability	0.8951	0.9977	0.9972
Expected Number of Failures	0.219	0.197	0.197
MTTFF	2942.9017	3553.0187	3553.0187
Uptime	644.4955	718.3369	717.9709
Total Downtime	75.5045	1.6631	2.0291

	With maintenance (5 times)	With maintenance (10 times)
Mean Availability (All Events):	0.9956	0.9932
Expected Number of Failures:	0.2	0.217
MTTFF:	3491.825	3259.4603
Uptime:	716.7969	715.0892
Total Downtime:	3.2031	4.9108

With maintenance (original) is using the data in table 4.13 while with maintenance (double) is doubling the value in table 4.13. This study showed that with maintenance, the availability will be increase. However, the sensitivity study shows that system availability change as the repair time changes. The availability of original (0.9977) is decrease to 0.9972 (double), 0.9956 (5 times) and 0.9932 (10 times). This showed that it is important to minimize repair time. Some of the thing that can be done to minimize the repair time is to ensure the labor quality, availability of spare parts and increasing the respond time when a failure occurred.

Note: Using 720 hours and the repair time (original, double, 5 times and 10 times) is based on the study by Yim H. T. et al. (1998)

After looking at the system availability, now the author wants to go through block availability. The result of block availability is showed at table 4.15.

Table 4.15: Block availability ranking

Block availability ranking				
Rank	No maintenance		With maintenance	
	Block	Avai.	Block	Avai.
1	M301	99.88%	T354 {Regeneration}	99.99%
2	M351 {Regeneration}	99.72%	T301	99.99%
3	XV3003	99.62%	T352 {Regeneration}	99.99%
4	G301A	99.32%	T353 {Regeneration}	99.99%
5	G301B	99.12%	T351A {Regeneration}	99.99%
6	T301	98.87%	T661 {Regeneration}	99.99%
7	T351A {Regeneration}	98.75%	T351B {Regeneration}	99.99%
8	T352 {Regeneration}	98.31%	M351 {Regeneration}	99.99%
9	T354 {Regeneration}	98.14%	XV3003	99.99%
10	T353 {Regeneration}	98.00%	G301B	99.98%
11	T661 {Regeneration}	97.87%	G301A	99.97%
12	T351B {Regeneration}	97.77%	L301C	99.88%
13	L301C	96.79%	L301A	99.88%
14	L302B	96.70%	L301B	99.88%
15	L301B	96.12%	L302B	99.87%
16	L302A	95.46%	L302A	99.86%
17	L301A	95.17%	M301	99.83%

Overall, almost all the block availability is increased after maintenance is applied. However, for M301, the availability is reduced a bit. This is occurred due to the time taken to do corrective maintenance. Sometime, the equipment need to stop operate to do maintenance. So there will be some loses in availability. However, as the table showed, it is proof that maintenance within optimal time can improve availability. Without maintenance, the L301A has the lowest availability hence showed that the equipment is critical and need to be pay attention to improve the availability.

Next, the author looks into the downtime of blocks. In a plant, it is very crucial to reduce the downtime of equipment. Correct maintenance strategy can help to reduce the downtime. The effect on downtime with and without maintenance is showed in the table 4.16. Downtime mean that the time that equipment fail to perform its function (unavailability time). It is usually occur because of unplanned event, equipment fail or routine maintenance.

Table 4.16: Block downtime ranking

Block downtime ranking				
Rank	No maintenance		With maintenance	
	Block	Time	Block	Time
1	L301A	34.788	M301	1.2076
2	L302A	32.6695	L302A	0.99
3	L301B	27.9702	L302B	0.9592
4	L302B	23.7378	L301B	0.8505
5	L301C	23.1206	L301A	0.8368
6	T351B {Regeneration}	16.0652	L301C	0.8339
7	T661 {Regeneration}	15.31	G301A	0.1945
8	T353 {Regeneration}	14.3958	G301B	0.154
9	T354 {Regeneration}	13.3643	XV3003	0.096
10	T352 {Regeneration}	12.1457	M351 {Regeneration}	0.088
11	T351A {Regeneration}	8.987	T351B {Regeneration}	0.063
12	T301	8.1686	T661 {Regeneration}	0.0615
13	G301B	6.323	T351A {Regeneration}	0.0585
14	G301A	4.9053	T353 {Regeneration}	0.057
15	XV3003	2.7276	T352 {Regeneration}	0.054
16	M351 {Regeneration}	2.0113	T301	0.051
17	M301	0.8469	T354 {Regeneration}	0.048

5. CONCLUSION AND RECOMMENDATION

5.1. Conclusion

A RBD is a graphical representation of how the components of a system are reliability-wise connected. This method can provide a clear and concise diagram for the system. The method can provide prediction of system reliability and can easily change the value for equipment for sensitivity analysis.

From the diagram, the critical equipment can be detected. The plant should focus to improve the reliability of the lowest reliability/availability value in the diagram. They can improve the preventive maintenance for the equipment, do redundancy (parallel) or try to find the root cause of the equipment's problem. The redundancy might be very expensive as the plant will need to buy new equipment and install as a parallel unit in the system. Redundancy surely will improve the reliability of the system. However, doesn't mean that it will be good too in term of cost benefit wise. Thorough investigation will be needed before making that decision.

The RAM field is very wide. If a complete RAM can be done, it can help the maintenance and improvement in various ways. There are several other method and analysis to develop RAM. It will be nice if all method can be done and the result can be compared to gain more accurate analysis. In a nut shell, RAM is an interesting area. A good RAM can be a huge different in term production of a plant with the other.

5.2. Recommendation

In the beginning of the project, the author is suppose to come up with a RBD and assessed the reliability of DHU at PGB. With the help of expert, the author has success in building a RBD of DHU. However, this project cannot be continued by using actual failure data from PGB since they are not able to provide the necessary data on time. To cope with this problem, the author with the advice of supervisor and expert has decided to continue the project by using assumption (for static reliability) and use OREDA handbook as real data. Using the static reliability cannot determine the real reliability of the DHU. Static reliability neglected the effect of time hence in the real situation, time play a major role as equipment reliability will get lower over time.

On the other hand, OREDA too is not quite reliable to be used in determining the reliability of DHU at PGB. The OREDA is based on the real equipment and real conditioning. However, OREDA can be very general. The operating condition, temperature, pressure and working fluid might be different than DHU in PGB. So the DHU in PGB might have better or lower reliability compare to the OREDA. The location too can affect the reliability. For example, the PGB is located near a beach. The equipments there will easily corrode compare to the other places.

Based on the entire problem encounter during doing the project, the author would like to suggest that, it would be great if the analysis done by using the actual data received from PGB. By using the actual data, some other analysis can be done such as to validate the data, to find the distribution that fit the data, what is the effect if using the other distribution, and the analysis can be extend to assess availability of the system. Another suggestion is to send the author to the PGB and meet the reliability engineer there. As a result of that, the author can have more understanding on the plant and reliability analysis that being used at PGB.

6. REFERENCES

- Carazas, F. J. G. and Souza, G. F. M. (2009). Availability analysis of gas turbine used in power plants, *International Journal of Thermodynamics Vol. 12 (No. 1)*, 28-37
- Cox, S. and Tait, R. (1998). *Safety, Reliability and Risk Management: an integrated approach 2nd edition*. UK: Butterworth-Heinemann.
- Davidson, J (1998). *The reliability of mechanical system*. London: Mechanical Engineering Publications Limited, IMechE
- Department of the Army (2007). *Technical Manual – Reliability/Availability of Electrical & Mechanical System for Command, Control, Communications, Computer, Intelligence, Surveillance and Reconnaissance (C4ISR) Facilities*
- Dhillon, B. S. and Yang, N. (1997). Comparisons of Block Diagram and Markov Method System Reliability and Mean Time To Failure Results for Constant and Non-constant Unit Failure Rates in Microelectron. *Reliability Vol. 37, No. 3*. 505-509.
- Eti, M. Ogaji, S. and Probert, S. (2007). Integrating reliability, availability, maintainability and supportability with risk analysis for improved operation of the Afam thermal power-station. *Applied Energy 84*, 202-221.
- Gandhidasan, P. (2003). Parametric analysis of natural gas dehydration by a Triethylene Glycol solution. *Energy Sources*, 25:189–201,
- Gandhidasan, P. Al-Farayedhi, A. A. Al-Mubarak, A. A. (2001). Dehydration of natural gas using solid desiccants, *Energy 26*, 855–868,
- Gupta, S. Tewari, P. C. and Sharma, A. K. (2011). Development of simulation model for performance evaluation of feed water system in a typical thermal power plant, *in J. Ind. Eng. Int.* 7 (12), 1-9

- Heizer, J. and Render, B. (2011). *Operations Management Tenth Edition*. New Jersey: Pearson Education inc.
- Kawauchi, Y. Yamaji, K. Sato, H. Kee, C. K. and Saad, S. (2004). A Plant Life Extension Project On Gas Processing Plant-1 (GPP-1) In Malaysia
- Kidnay, A. J. and Parrish, W. R. (2006). *Fundamental of Natural Gas Processing*, Boca Ranton: Taylor and Francis group.
- Langseth, H., Haugen, K. and Sandtory, H. (1998). Analysis of OREDA DATA for Maintenane Optimisation. SINTEF Industrial Management Safety and Reliability.
- Mokhatab, S. and Meyer, P. (2009). Selecting Best Technology Lineup for Designing Gas Processing Units in GPA Europe Sour Gas Processing Conference, Sitges, Spain 13th -15th May
- Mokhatab, S. Poe, W. A and Speight, J. G (2006). *Handbook of Natural Gas Transmission and Processing*, U.S.A & UK: Elsevier Inc.
- Offshore Reliability Data Handbook 1st Edition (1984)*
- Offshore Reliability Data Handbook Volume 1- Topside Equipment, 5th Edition (2009).*
- ReliaSoft Corporation. Graphical Method. Retrieved December 01, 2011 from http://www.weibull.com/AccelTestWeb/graphical_method.htm.
- Yang, G. (2007) *Life Cycle Reliability Engineering*, New Jersey: John Wiley & Sons Inc
- Yim, H. T., Park, C. K., Kim, Y. J. and Ah, S.H (1998). Reliability/Availability Study for a Gas Processing Plant, *Chemical Industry and technology vol. 16 No. 6*, 568-575
- Younger, A. H. (2004). *Natural Gas Processing Principle and Technology – Part II*, University of Calgary. 17-1 -17-8

APPENDICES

Appendix 1: DHU reliability vs time (mean failure rate)	54
Appendix 2: DHU Probability Density Function (mean failure rate)	55
Appendix 3: DHU reliability vs time (upper failure rate)	56
Appendix 4: DHU Probability Density Function (upper failure rate)	57
Appendix 5: Regeneration reliability vs time (mean failure rate)	58
Appendix 6: Regeneration Probability Density Function (mean failure rate)	59
Appendix 7: Regeneration reliability vs time (upper failure rate)	60
Appendix 8: Regeneration Probability Density Function (upper failure rate)	61
Appendix 9: What-if analysis trials	62
Appendix 10: OREDA – Heat exchanger	63
Appendix 11: OREDA – Knock out drums	64
Appendix 12: OREDA – Dryer	65
Appendix 13: OREDA – Filters	66
Appendix 14: OREDA – Shut off valve	67
Appendix 15: Block Failures Ranking	68

Appendix 1: DHU reliability vs time (mean failure rate)

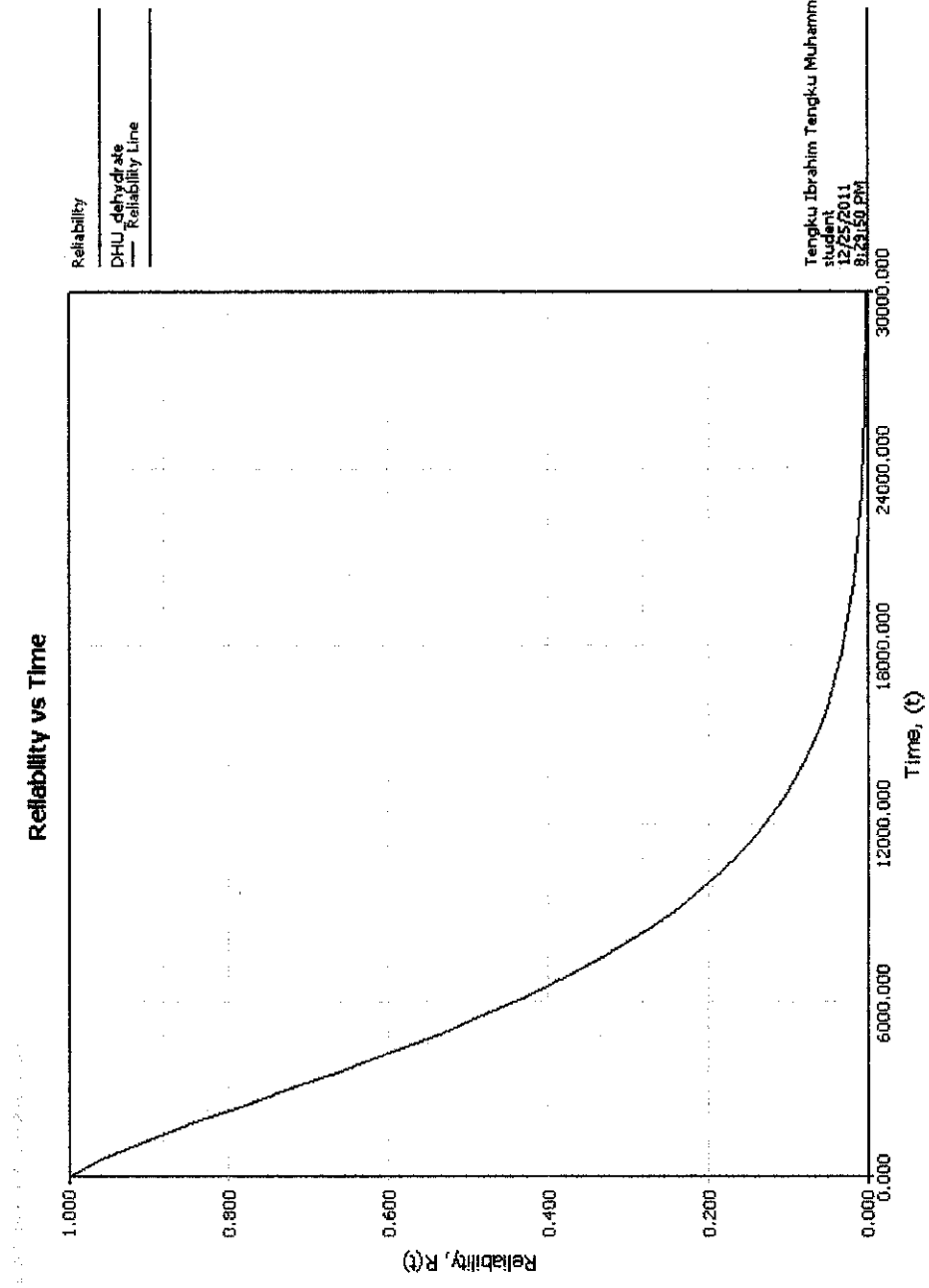

Appendix 2: DHU Probability Density Function (mean failure rate)

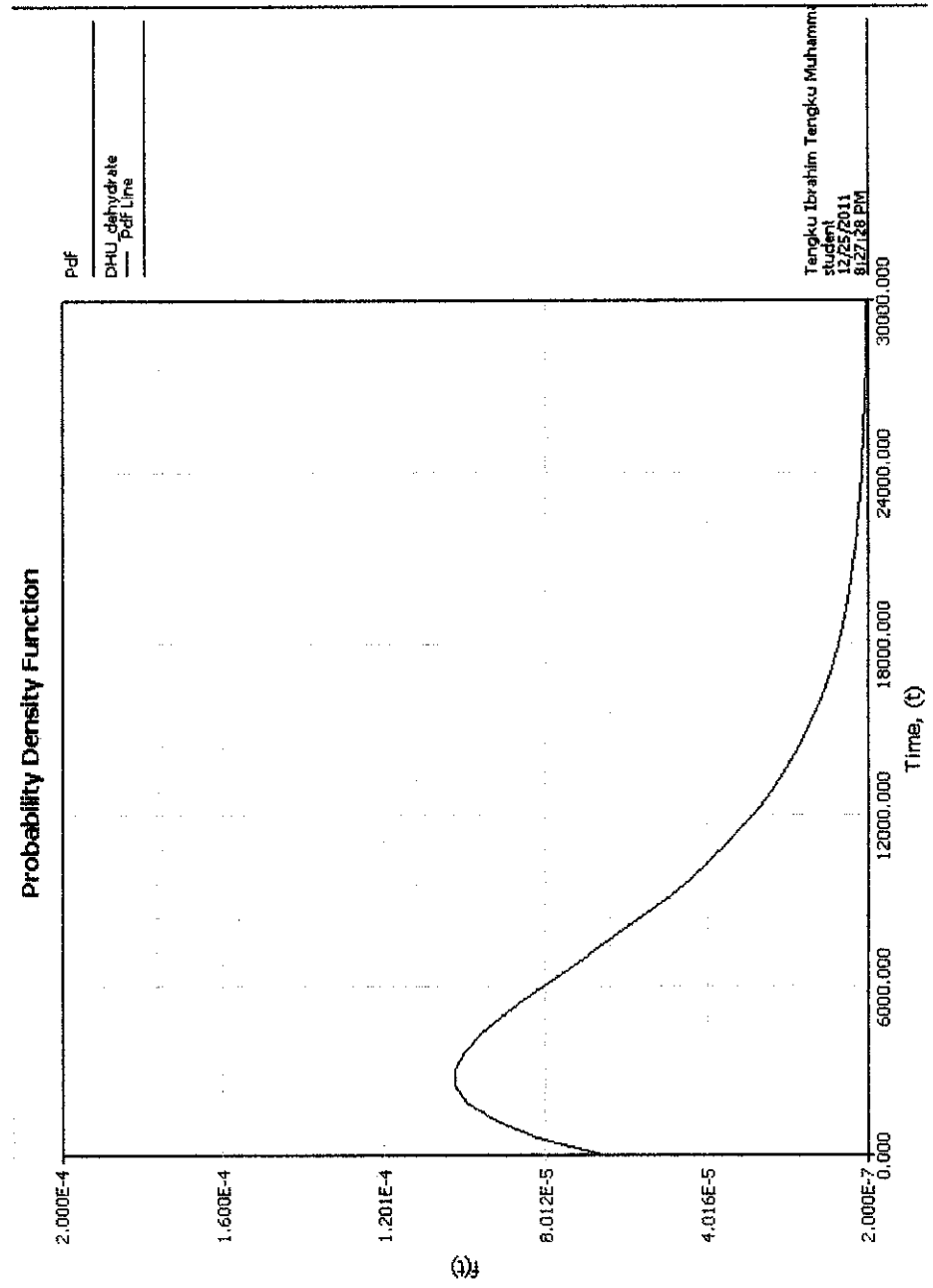

Tengku Ibrahim Tengku Muhamad
student
12/25/2011
8:27:38 PM

Appendix 3: DHU reliability vs time (upper failure rate)

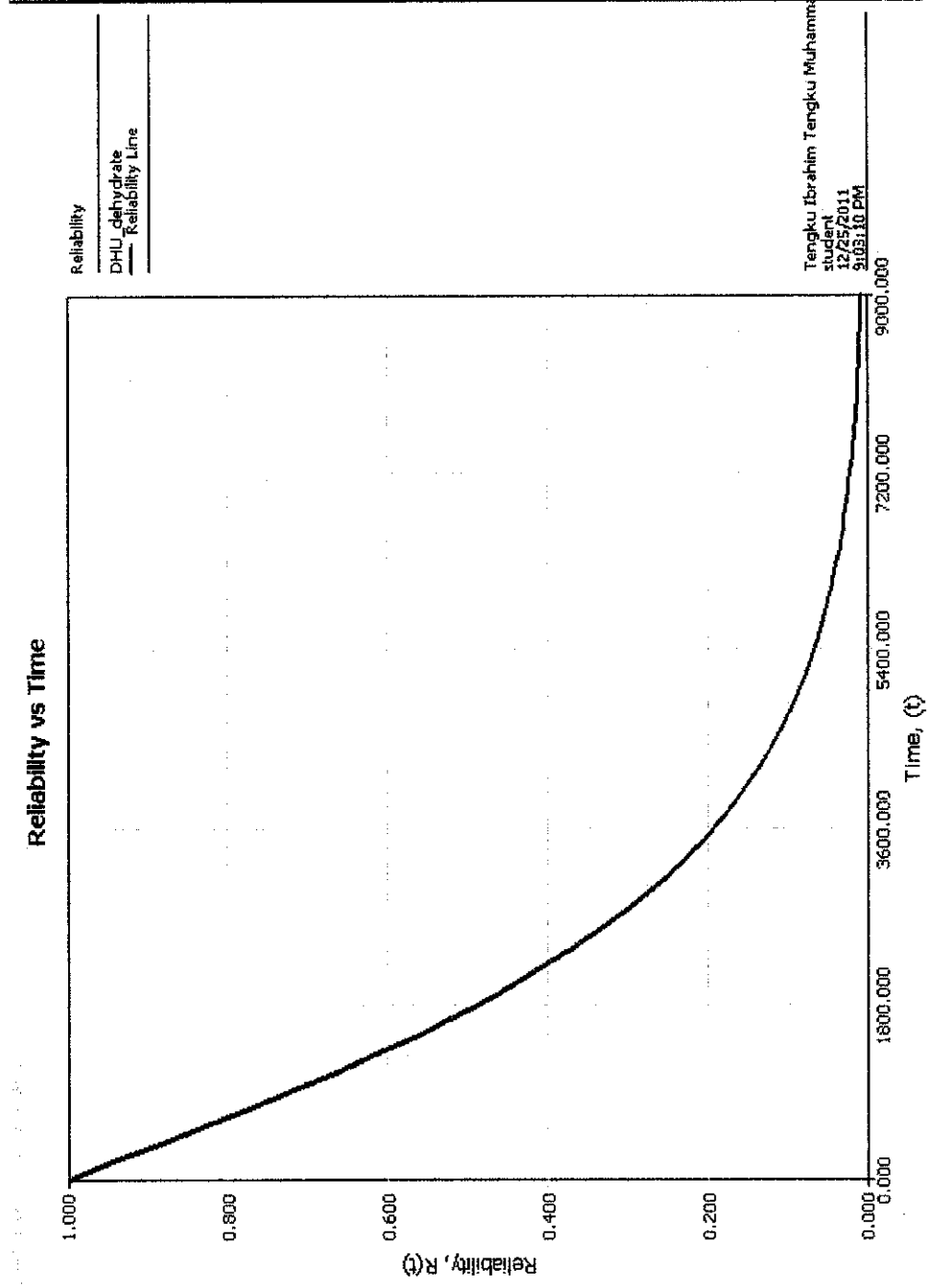

Appendix 4: DHU Probability Density Function (upper failure rate)

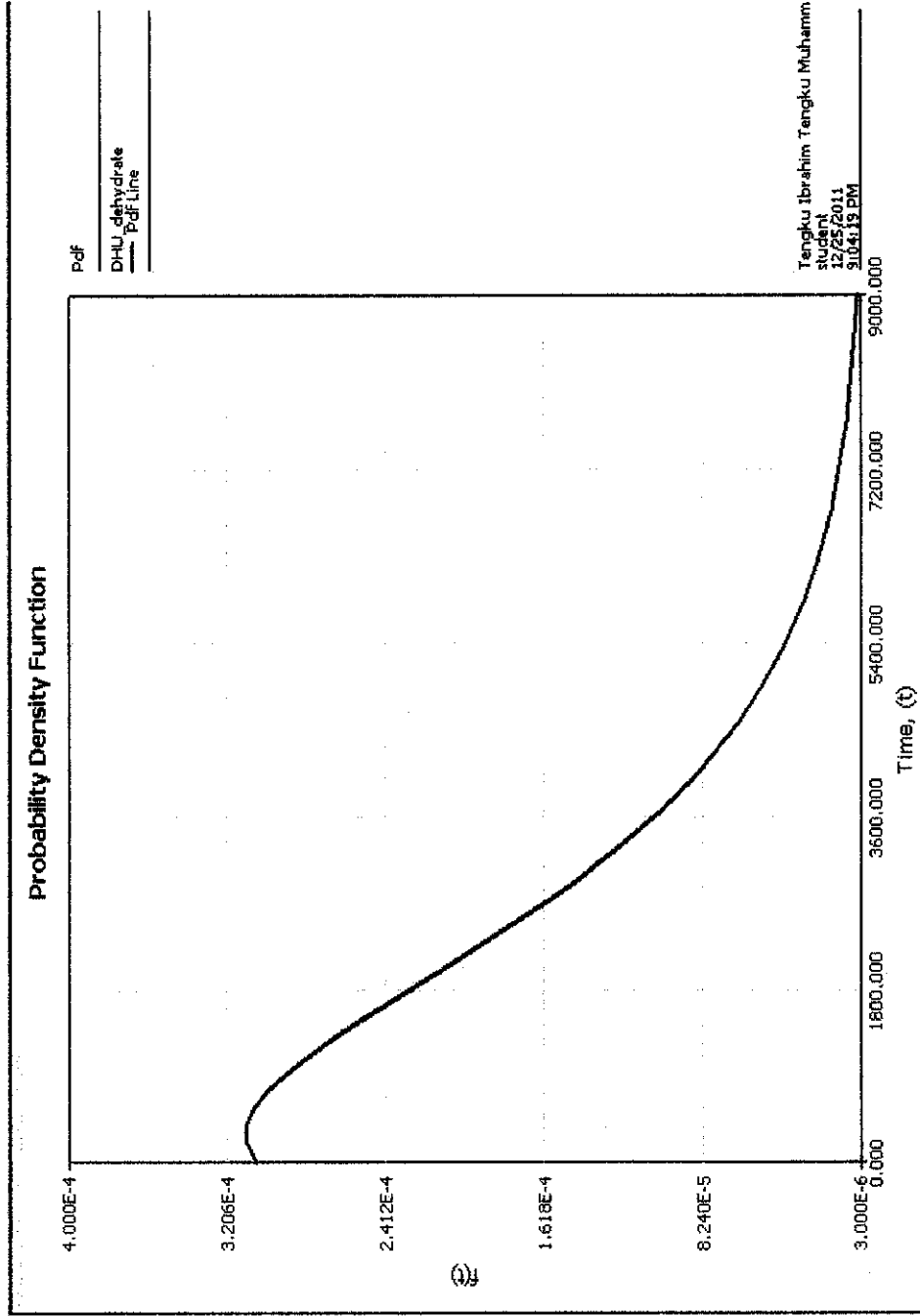

Appendix 5: Regeneration system reliability vs time (mean failure rate)

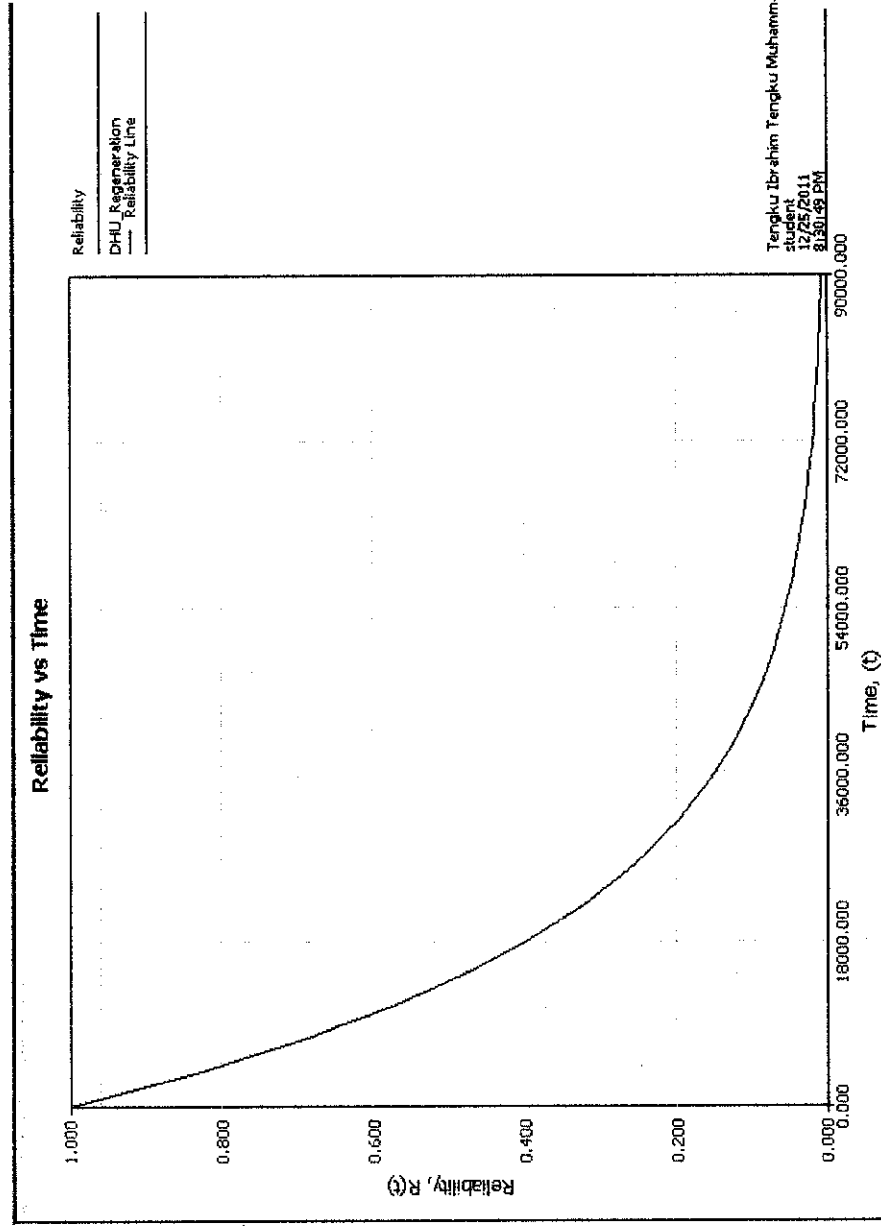

Tengku Ibrahim Tengku Muhammm.
student
12/25/2011
8:30:49 PM

Appendix 6: Regeneration system Probability Density Function (mean failure rate)

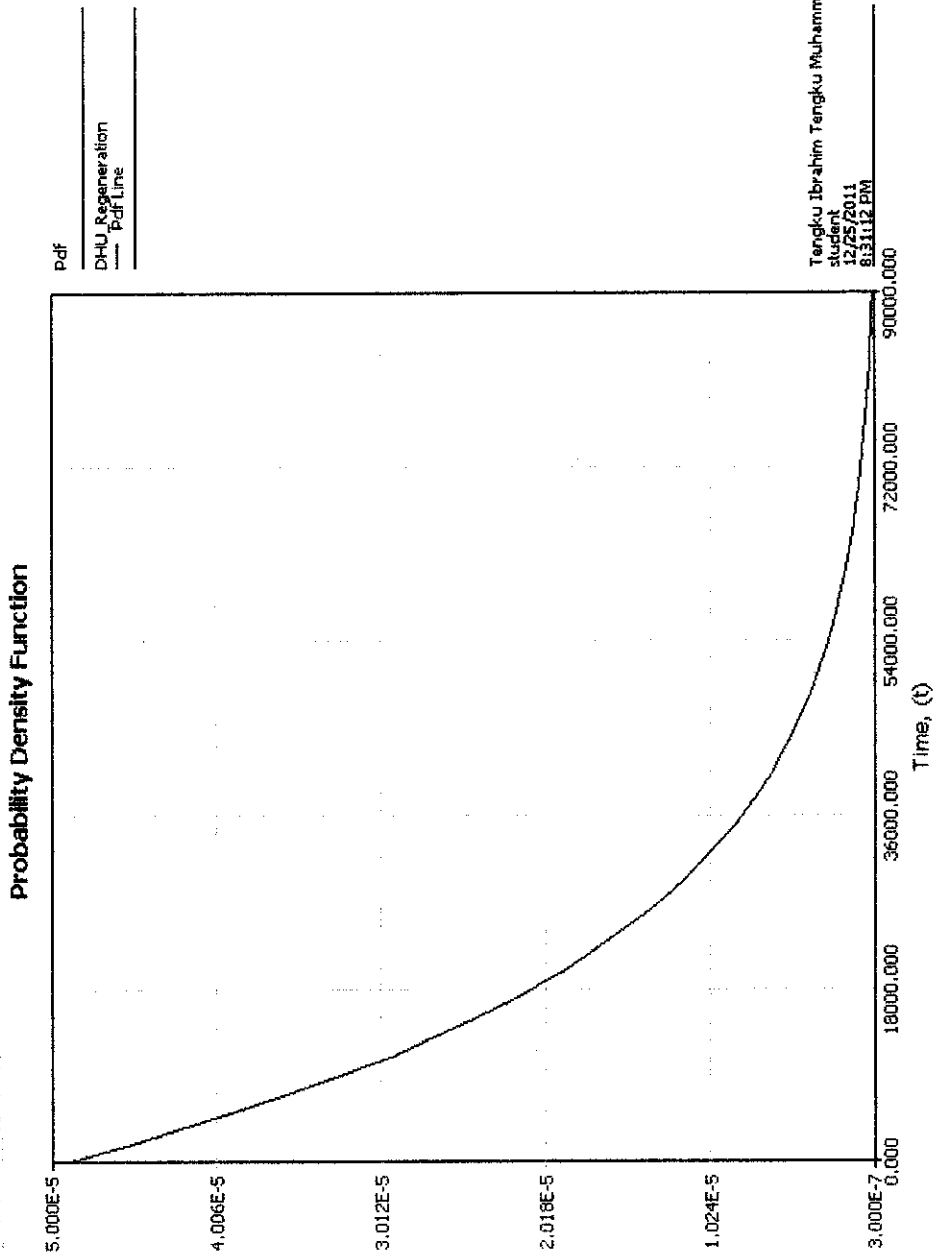

Tengku Ibrahim Tengku Muhammm
student
12/25/2011
8:31:12 PM

Appendix 7: Regeneration system reliability vs time (upper failure rate)

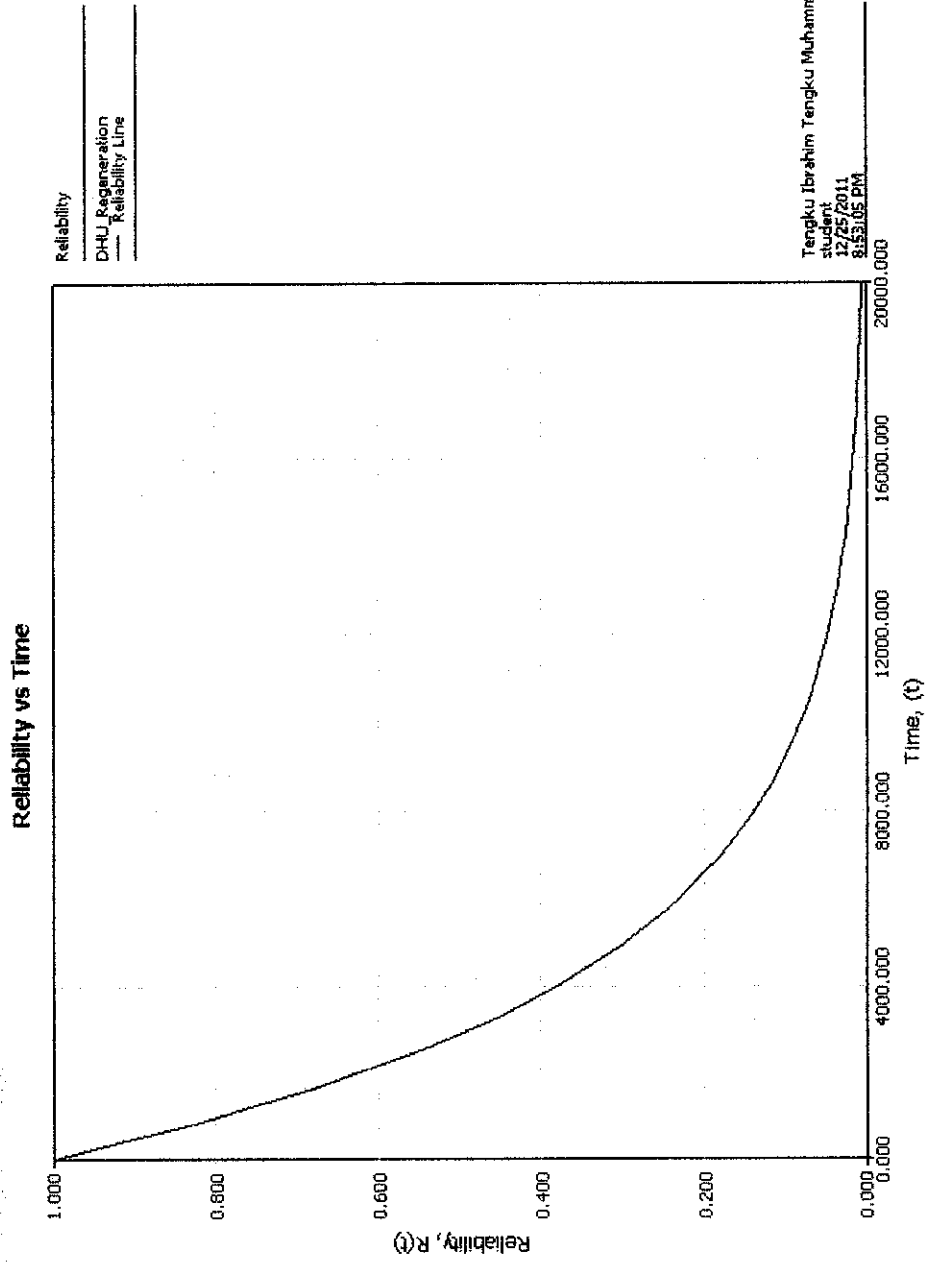

Tengku Ibrahim Tengku Muhamad
student
12/25/2011
8:53:05 PM

Appendix 8: Regeneration system Probability Density Function (upper failure rate)

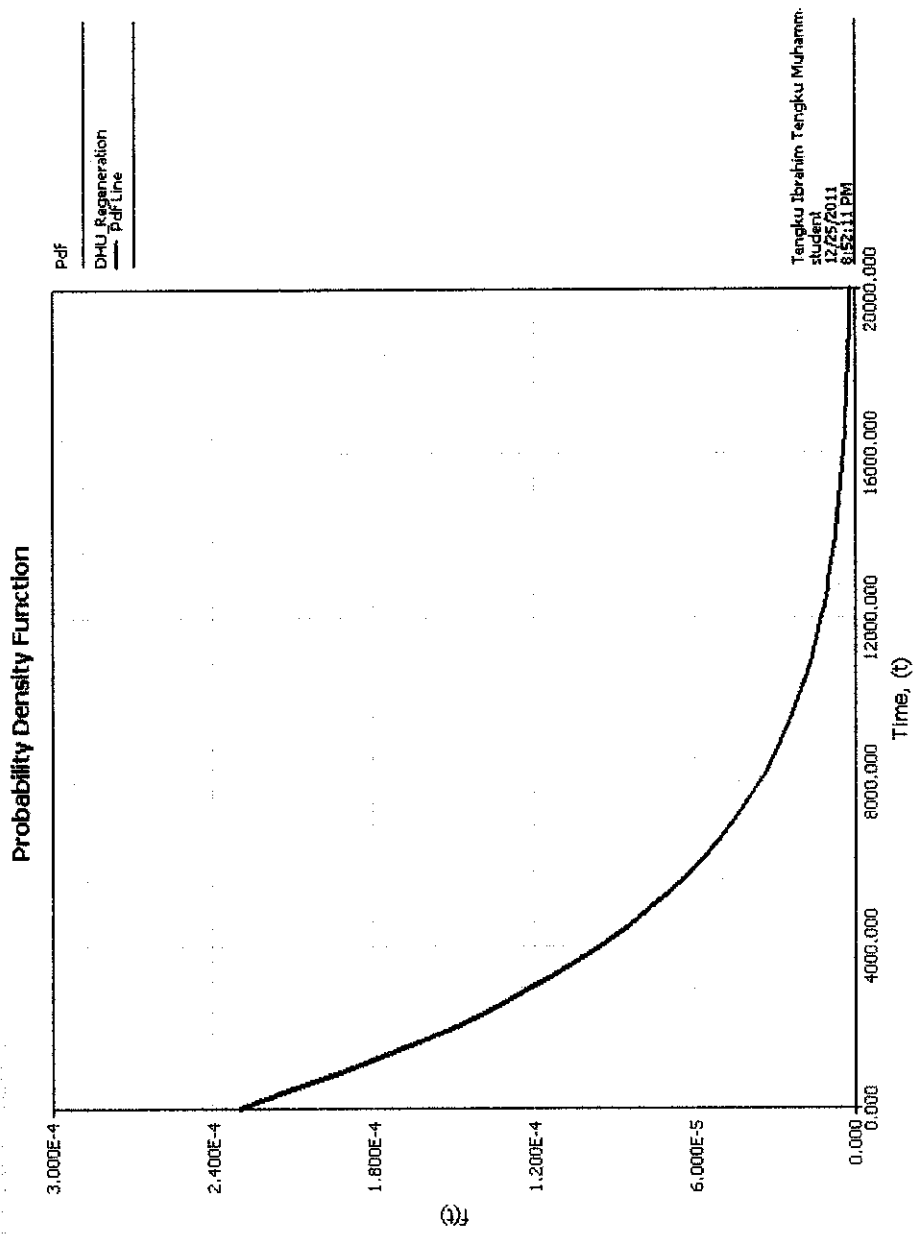

Tengku Ibrahim Tengku Muhamad
student
17/25/2011
8:52:11 PM

Appendix 9: What-if analysis trials

Block	Reliability	Prob. of Failure	Remarks
1 00 2	1	0	
2 00 3	1	0	
Regeneration	0.8458	0.1542	
XV3003	0.9891	0.0109	
G301B	0.9829	0.0171	
G301A	0.9829	0.0171	
M301	0.9971	0.0029	
T301	0.9601	0.0399	
L302B	0.9646	0.0354	20000mttf
L302A	0.9646	0.0354	20000mttf
L301C	0.9646	0.0354	20000mttf
L301B	0.9646	0.0354	20000mttf
L301A	0.9646	0.0354	20000mttf

Reliability = 0.7966

Block	Reliability	Prob. of Failure	Remarks
1 00 2	1	0	
2 00 3	1	0	
Regeneration	0.8458	0.1542	
XV3003	0.9891	0.0109	
G301B	0.9829	0.0171	
G301A	0.9829	0.0171	
M301	0.9971	0.0029	
L302B	0.9132	0.0868	
L302A	0.9132	0.0868	
L301C	0.9132	0.0868	
L301B	0.9132	0.0868	
L301A	0.9132	0.0868	
T301	0.9646	0.0354	20000mttf

Reliability = 0.7813

Block	Reliability	Prob. of Failure	Remarks
1 00 2	1	0	
2 00 3	1	0	
Regeneration	0.8458	0.1542	
XV3003	0.9891	0.0109	
G301B	0.9829	0.0171	
G301A	0.9829	0.0171	
M301	0.9971	0.0029	
L302B	0.9132	0.0868	
L302A	0.9132	0.0868	
L301C	0.9132	0.0868	
L301B	0.9132	0.0868	
L301A	0.9132	0.0868	
T301	0.9716	0.0284	25000mttf

Reliability = 0.7869

Appendix 10: OREDA – Heat exchanger

Taxonomy no 3.1.4		Item Mechanical Equipment Heat Exchangers Shell and tube									
Population 2	Installations 1	Aggregated time in service (10 ⁶ hours)					No of demands				
		Calendar time ^a 0.0985		Operational time ^T 0.0730			Active rep. hrs		Manhours		
Failure mode	No of failures	Failure rate (per 10 ⁶ hours)					Active rep. hrs		Manhours		
		Lower	Mean	Upper	SD	n / r	Mean	Max	Mean	Max	
Incipient	1*	0.51	10.15	48.15	10.15	10.15	1.5	1.5*	1.5	1.5*	
Abnormal instrument reading	1†	0.68	13.70	64.99	13.70	13.70					
	1*	0.51	10.15	48.15	10.15	10.15	1.5	1.5*	1.5	1.5*	
	1†	0.68	13.70	64.99	13.70	13.70					
All modes	1*	0.51	10.15	48.15	10.15	10.15	1.5	1.5*	1.5	1.5*	
Comments	1†	0.68	13.70	64.99	13.70	13.70					

Appendix 11: OREDA – Knock out drums

OREDA-84

143

OREDA-84

Taxonomy no 2.1.1		Item Process Systems Vessels Separators/FWKO (Free Water Knock Out) Drums						
Population 89	Samples 10	Aggregated time in service (10 ⁶ hours)			Active repair (hours)	No of demands		
		Calendar time † 1 7061		Operational time † 1 6025		Min	Mean	Max
Failure mode	No of failures	Failure rate (per 10 ⁶ hrs)			Repair (manhours)	Min	Mean	Max
		Lower	Mean	Upper				
Critical	2 *	0.049	1.2	4.0	-	-	3000	-
	2 †	0.050	1.2	4.2	-	-	-	-
Major leakage	1 *	0.030	0.59	2.8	-	-	5900	-
	1 †	0.032	0.62	3.0	-	-	-	-
Break, breach or puncture	1 *	0.030	0.59	2.8	-	-	41	-
	1 †	0.032	0.62	3.0	-	-	-	-
Degraded	171 *	62	95	130	-	-	5.5	-
	171 †	68	100	130	-	-	-	-
Failed transmitter or controller	163 *	53	89	130	-	1	5	20
	163 †	56	90	130	-	-	-	-
Cracked	7 *	0	5.2	14	-	-	12	-
	7 †	0	8.9	21	-	-	-	-
Unknown	1 *	0.030	0.59	2.8	-	-	12	-
	1 †	0.032	0.62	3.0	-	-	-	-
Incipient	84 *	29	54	81	-	-	15	-
	84 †	31	69	110	-	-	-	-
Minor leakage	24 *	5.8	16	27	-	1	10	36
	24 †	6.5	20	35	-	-	-	-
Eroded/corroded	4 *	0.80	2.3	5.4	-	4	71	100
	4 †	0.85	2.5	5.7	-	-	-	-
Faulty weld	3 *	0	1.7	5.3	-	-	98	-
	3 †	0	1.7	5.5	-	-	-	-
Unknown	53 *	16	34	53	-	1	8	32
	53 †	18	45	73	-	-	-	-
Unknown	6 *	0.29	4.0	9.2	-	-	170	-
	6 †	0.42	5.9	13	-	-	-	-
Failed	6 *	0.29	4.0	9.2	-	54	170	290
	6 †	0.42	5.9	13	-	-	-	-
All modes	263 *	120	150	190	-	-	33	-
	263 †	130	180	220	-	-	-	-
Comments								
<p>Note: The estimates were in some cases based on different subsets of samples for the different failure modes. This results from tests of statistical consistence among samples, see sect 3.4.</p>								

Appendix 12: OREDA - Dryer

L301

OREDA-2009

365

Volume 1 – Topside Equipment

Taxonomy no 3.2.6		Item Mechanical Equipment Vessels Mol sieve dryer								
Population 6	Installations 1	Aggregated time in service (10 ⁶ hours)					No of demands			
		Calendar time * 0.1053			Operational time † 0.1032		Active rep. hrs		Manhours	
Failure mode	No of failures	Failure rate (per 10 ⁶ hours)					Mean	Max	Mean	Max
		Lower	Mean	Upper	SD	n/t				
Incipient	7*	31.21	66.50	124.92	25.13	66.50	-	-	10	37*
	7†	31.83	67.83	127.42	25.64	67.83	-	-		
Abnormal instrument reading	1*	0.47	9.50	45.08	9.50	9.50	-	-	3.0	3.0*
	1†	0.48	9.69	45.98	9.69	9.69	-	-		
External leakage - Process medium	5*	18.71	47.50	99.89	21.24	47.50	-	-	6.2	20*
	5†	19.09	48.45	101.89	21.67	48.45	-	-		
Structural deficiency	1*	0.47	9.50	45.08	9.50	9.50	-	-	37	37*
	1†	0.48	9.69	45.98	9.69	9.69	-	-		
All modes	7*	31.21	66.50	124.92	25.13	66.50	-	-	10	37*
	7†	31.83	67.83	127.42	25.64	67.83	-	-		
Comments										

Appendix 13: OREDA - Filters

Taxonomy no		Item						
4.2.3		Utility Systems Ventilation and Heating Systems Filters						
Population	Samples	Aggregated time in service (10 ⁶ hours)				No of demands		
		Calendar time [†]		Operational time [†]				
46	4	5030						
Failure mode	No of failures	Failure rate (per 10 ⁶ hrs)			Active repair (hours)	Repair (manhours)		
		Lower	Mean	Upper		Min	Mean	Max
Critical	6 *	5.2	12	24	-	-	-	-
Clogged	5 *	3.9	9.9	21	-	-	11	-
Ruptured	1 *	0.10	2.0	9.4	-	4	11	23
Degraded	8 *	8.0	16	29	-	-	14	-
Partially clogged	7 *	6.5	14	26	-	-	15	-
Internal leakage	1 *	0.10	2.0	9.4	-	6	15	40
						-	11	-
All modes	14 *	17	28	44	-	-	13	-
Comments								

Note: The estimates were in some cases based on different subsets of samples for the different failure modes. This results from tests of statistical consistence among samples, see sect 3.4.

Appendix 14: OREDA – Shut off valve

Taxonomy no 4.4.14		Item Valves Valves described by application Shut-off								
Population 50	Installations 5	Aggregated time in service (10 ⁶ hours)					No of demands			
		Calendar time * 0.8467		Operational time † 0.8404			Active rep. hrs		Demand hrs	
Failure mode	No of failures	Failure rate (per 10 ⁶ hours)					Active rep. hrs		Demand hrs	
		Lower	Mean	Upper	SD	n/τ	Mean	Max	Mean	Max
Critical	1*	2E-3	3.59	15.20	5.85	1.18	8.0	8.0*	8.0	8.0*
	1†	2E-3	3.61	15.29	5.88	1.19				
External leakage - Utility medium	1*	2E-3	3.59	15.20	5.85	1.18	8.0	8.0*	8.0	8.0*
	1†	2E-3	3.61	15.29	5.88	1.19				
Degraded	14*	0.34	22.74	71.93	25.82	16.53	4.1	11*	13	40
	14†	0.33	23.43	74.44	26.80	16.66				
External leakage - Process medium	2*	1E-3	4.36	19.22	7.55	2.36	-	-	1.0	2.0*
	2†	1E-3	4.53	19.96	7.83	2.38				
External leakage - Utility medium	1*	2E-3	3.59	15.20	5.85	1.18	11	11*	11	11*
	1†	2E-3	3.61	15.29	5.88	1.19				
Minor in-service problems	3*	0.05	2.75	8.60	3.06	3.54	2.0	2.0*	40	40*
	3†	0.05	2.78	8.64	3.06	3.57				
Structural deficiency	1*	1E-3	1.96	8.23	3.16	1.18	-	-	6.0	6.0*
	1†	1E-3	2.03	8.61	3.31	1.19				
Valve leakage in closed position	3*	0.05	2.75	8.60	3.06	3.54	4.0	6.0*	12	12*
	3†	0.05	2.78	8.64	3.06	3.57				
Other	4*	1E-3	9.00	40.73	16.19	4.72	-	-	2.0	2.0*
	4†	1E-3	9.38	42.21	16.74	4.76				
Incipient	1*	0.01	1.03	3.28	1.18	1.18	4.0	4.0*	12	12*
	1†	0.01	1.04	3.30	1.19	1.19				
Internal leakage	1*	0.01	1.03	3.28	1.18	1.18	4.0	4.0*	12	12*
	1†	0.01	1.04	3.30	1.19	1.19				
All modes	16*	1.50	27.02	80.04	26.64	18.90	4.6	11*	13	40
	16†	1.46	27.77	82.71	27.58	19.04				
Comments										

Appendix 15: Block Failures Ranking

Block Failures Ranking				
Rank	No maintenance		With maintenance	
	Block	Expected NOF	Block	Expected NOF
1	L302A	0.091	L302A	0.1
2	L301A	0.084	L302B	0.096
3	L301B	0.08	L301B	0.086
4	L302B	0.065	L301C	0.084
5	L301C	0.059	L301A	0.084
6	T351B {Regeneration}	0.043	T351B {Regeneration}	0.042
7	T354 {Regeneration}	0.039	T661 {Regeneration}	0.041
8	T353 {Regeneration}	0.039	T351A {Regeneration}	0.039
9	T661 {Regeneration}	0.037	T353 {Regeneration}	0.038
10	T352 {Regeneration}	0.035	T352 {Regeneration}	0.036
11	T351A {Regeneration}	0.027	T301	0.034
12	T301	0.024	T354 {Regeneration}	0.032
13	G301B	0.017	G301A	0.018
14	G301A	0.012	G301B	0.014
15	XV3003	0.011	XV3003	0.012
16	M351 {Regeneration}	0.005	M301	0.003
17	M301	0.003	M351 {Regeneration}	0.001