

**CERTIFICATION OF APPROVAL**

**Determination of Soluble Water Content in Organic Oil Study**

By

Farahani Irna Nazari

A project dissertation submitted to the  
Chemical Engineering Programme  
University Teknologi PETRONAS  
in partial fulfillment of the requirements for the  
**BACHELOR OF ENGINEERING (Hons)**  
**(CHEMICAL ENGINEERING)**

Approved by,

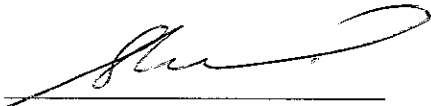

Dr. Shuhaimi Mahadzir,  
Project Supervisor.

**UNIVERSITI TEKNOLOGI PETRONAS**

**TRONOH, PERAK**

**January 2009**

## **CERTIFICATION OF ORIGINALITY**

This is to certify that I am responsible for the work submitted in this project, that the original work is my own except as specified in the references and acknowledgements, and that the original work contained herein have not been undertaken or done by unspecified sources or persons.



---

**(FARAHANI IRNA NAZARI)**

## **ACKNOWLEDGEMENT**

Throughout the progress of my Final Year Project, I would like to express my most heartfelt gratitude to my supervisor, Dr Shuhaimi Mahadzir for his tremendous job in monitoring and guiding me fully and for his patience with me all the way. He gave me a lot of input, ideas, perspective and feedbacks which helped me to improve my work outcome. Without him, this project can never be completed to this level.

I am also thankful to Final Year Research Project Coordinator, Mr Tazli Azizan for his tireless efforts and on-going support, advice as well as guidance. Without him also, this project would not have been done successfully.

Plus, I would like to thank my family members and friends for always being understanding and putting up with me whenever I was down in completing this project.

Also, to everyone who had been involved formally or informally in helping me making this project a success such as my examiners for my previous presentations for their time and ideas contributed, and to lab technicians for guiding me in laboratories all the way.

Finally, I hope that this report will give the readers some insight on this study. For whomever who will continue this project, all the best and hopefully this report can be beneficial for your project.

Thank you.

## TABLE OF CONTENTS

CERTIFICATION.....	i
CERTIFICATION OF ORIGINALITY.....	ii
ACKNOWLEDGEMENT.....	iii
1.0 ABSTRACT.....	1
2.0 INTRODUCTION.....	2
2.1 Background of Study.....	2
2.2 Problem Statement.....	4
2.3 Objectives and Scope of Study.....	4
3.0 LITERATURE REVIEW.....	5
3.2 Spectroscopic Methods.....	5
3.3 Thermal Analysis.....	11
4.0 METHODOLOGY.....	24
5.0 EXPERIMENTAL PROCEDURES.....	27
5.1 UV/ VIS Spectrometry.....	27
6.0 RESULTS AND DISCUSSION.....	33
6.1 Water as Base.....	33
6.2 Acetone as Base.....	33
6.3 No Base.....	35
7.0 CONCLUSIONS AND RECOMMENDATIONS.....	40
8.0 REFERENCES.....	42

## APPENDICES

UV-Visible Test Results

## LIST OF TABLES

Table 1: Standards for Karl Fischer Titration	10
Table 2: Sample size for different sample water content	10
Table 3: Processes amenable to study in TGA	14
Table 4: Possible processes giving enthalpic peaks in DSC	22
Table 5: Project Activities and Key Milestones	26
Table 6: Standard Samples Concentration	31
Table 23: Wavelength Selection for Water as Base	33
Table 24: Wavelength Selection for Acetonitrile as Base	33
Table 25: Wavelength Selection for No Base	35
Table 26: Properties of Bio-oil from Various Feedstocks	37
Table 27: Properties of Acetonitrile	38
Table 28: Spectral Data of Acetonitrile	38

### Appendix:

Table 8: Peak pick for 100% Acetone (Water Base)	
Table 9: Peak pick for 10% Acetone (Water Base)	
Table 10: Peak pick for 20% Acetone (Water Base)	
Table 11: Peak pick for 40% Acetone (Water Base)	
Table 12: Peak pick for 60% Acetone (Water Base)	
Table 13: Peak pick for 80% Acetone (Water Base)	
Table 14: Peak pick for 20% Water (Acetone Base)	
Table 15: Peak pick for 40% Water (Acetone Base)	
Table 16: Peak pick for 60% Water (Acetone Base)	
Table 17: Peak pick for 80% Water (Acetone Base)	
Table 18: Peak pick for 90% Water (Acetone Base)	
Table 19: Peak pick for 20% Water (No Base)	
Table 20: Peak pick for 40% Water (No Base)	
Table 21: Peak pick for 60% Water (No Base)	
Table 22: Peak pick for 80% Water (No Base)	59

## **1.0 ABSTRACT**

The objective of this project is to determine soluble water content in organic crude oil. Generally, water needs to be taken out from crude as it has several effects such as:

- Cost of production will increase as water will have to be removed by de-emulsification.
- Refineries do not accept crude with water content more than certain limit.
- Chances of corrosion of production facilities will increase.
- Production rate may be affected.
- Lifting cost will increase as water is also to be lifted.
- May lead to early requirement of artificial lift.
- Viscosity of produced fluid will increase, leading to higher pressure draw down.
- Degree of API of oil will be affected resulting in its selling price.

A few methods on how to determine the water content in miscible organic substance will be searched and will be tested as to see whether they are suitable to be used as a method for determination of soluble water content on organic crude oil.

Thus, the collection of technical details and data regarding the methods on water content determination in organic medium will be done. At the end of this study it is planned to test all the methods found by using any suitable and easy-to-get organic substance sample as before testing the organic crude to compare the results. It is to make better understanding and clarity of this study. Later, all the methods will be differentiated in terms of simplicity, costs and accuracy to choose the best method in determining soluble water content in organic crude oil.

Three methods which the equipments are available in UTP laboratories are searched through; Thermogravimetry (TGA), Differential Scanning Calorimetry (DSC) and UV-Visible Spectroscopy, besides the earlier suggested; Karl-Fischer as its titrator is not available in UTP.

## 2.0 INTRODUCTION

### 2.1 Background of Study

One of the organic crude oil produced in Malaysia is Genting Bio-Oil where its first pilot plant in Ayer Itam, Johor. Genting Bio-Oil is made from waste generated from oil palm plantations, such as empty fruit bunches. It can be used in a wide variety of applications, including direct co-combustion at power plants and boilers for heat and electricity generation. Combustion trials were undertaken in Japan and Europe during the year.

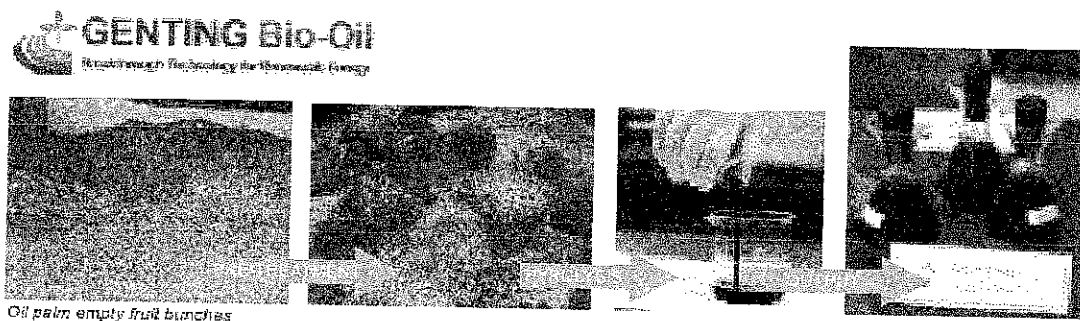

**Figure 1: Process development of Genting Bio-Oil**

#### 2.1.1 Biomass

Biomass refers to living and recently dead biological material that can be used as fuel or for industrial production. Most commonly, biomass refers to plant matter grown for use as biofuel, but it also includes plant or animal matter used for production of fibers, chemicals or heat. Biomass may also include biodegradable wastes that can be burnt as fuel. It excludes organic material which has been transformed by geological processes into substances such as coal or petroleum.

Biomass is grown from several plants, including miscanthus, switchgrass, hemp, corn, poplar, willow, sugarcane, and oil palm (palm oil). The particular plant used is usually not very important to the end products, but it does affect the processing of the raw

material. Production of biomass is a growing industry as interest in sustainable fuel sources is growing.

### **2.1.2 Pyrolysis**

Pyrolysis is the chemical decomposition of organic materials by heating in the absence of oxygen or any other reagents, except possibly steam.

It is used in chemical analysis to break down complex matter into simpler molecules for identification, for example by pyrolysis gas chromatography mass spectrometry.

#### **Processes for biomass pyrolysis**

Fast pyrolysis of biomass feedstocks is required to achieve high yields of liquids. It is characterized by rapid heating of the biomass particles and a short residence time of product vapors (0.5 to 2 s). Rapid heating means that the biomass must be ground into fine particles and that the insulating char layer that forms at the surface of the reacting particles must be continuously removed.

Since pyrolysis is slightly endothermic, various methods have been proposed to provide heat to the reacting biomass particles:

- Partial combustion of the biomass products through air injection. This results in poor-quality products.
- Direct heat transfer with a hot gas, ideally product gas that is reheated and recycled. The problem is to provide enough heat with reasonable gas flow-rates.
- Indirect heat transfer with exchange surfaces (wall, tubes). It is difficult to achieve good heat transfer on both sides of the heat exchange surface.
- Direct heat transfer with circulating solids: Solids transfer heat between a burner and a pyrolysis reactor. This is an effective but complex technology.



## **2.2 Problem Statement**

Organic crude oil is processed from batch process with slow reaction rate where hydrocarbon molecules are oxidized and form water; thus the results of soluble water content in organic crude oil. The water needs to be removed but in order to do that, water content needs to be determined. Unlike mineral crude, organic crude oil is highly unstable. Thus, any water content determination methods which involve applying heat to the organic crude can not be used. Other alternatives to measure the water content need to be find out and tested whether they are suitable for water content determination in organic crude oil or not.

## **2.3 Objective and Scope of Study**

The objectives of this study are originally to investigate and predict water content determination in organic crude oil and to compare the results from all those methods tested in order to choose the best method in terms of simplicity, costs and accuracy. In order to achieve these, a few tasks and research need to be carried out by collecting all technical details regarding the water content determination in organic solvents. Experimental procedures for all those methods will be created and conducted in the laboratory by using any suitable organic substance for calibration purposes, followed with using the real organic crude oil. However, organic oil was unable to be obtained. Yet, this studies is still proceed even without the usage of organic oil which replaced by an organic substance, acetonitrile. From this study, the effect of different concentration of soluble water content in an organic substance (acetonitrile) will be observed in the place of organic oil by using suitable and appropriate analytical procedures. The relationship between different concentration of water and the results from the tests conducted will be observed.

A few recommendations are to be made based on the findings of this study towards the end of this report.

### 3.0 LITERATURE REVIEW

A few methods for determination of water content in organic solvent systems that were studied in this project include:

- i) Volumetric Karl-Fischer Titration
- ii) Coulometric Karl Fischer Titration
- iii) Spectroscopic Absorption
- iv) Thermogravimetric Analysis (TGA)
- v) Differential Scanning Calorimetry (DSC)
- vi) UV-Visible Spectrometer

Among all those methods above, only 3 methods are available in UTP's laboratory.

#### 3.2 Spectroscopic Methods

Spectroscopic methods utilize the interaction of electromagnetic radiation with materials to obtain information about their composition, e.g., X-rays, UV-visible, NMR, microwaves and IR.

The spectroscopic methods developed to measure the moisture content are based on the fact that water absorbs electromagnetic radiation at characteristic wavelengths that are different from the other components in the substance matrix. The most widely used physical methods are based on measurements of the absorption of microwave or infrared energy by substance. Microwave and infrared radiation are absorbed by materials due to their ability to promote the vibration and/or rotation of molecules. The analysis is carried out at a wavelength where the water molecules absorb radiation, but none of the other components in the substance do. A measurement of the absorption of radiation at this wavelength can then be used to determine the moisture content: the higher the moisture content, the greater the absorption.

Instruments based on this principle are commercially available and can be used to determine the moisture content in a few minutes or less. It is important not to confuse infrared and microwave absorption methods with infrared lamp and microwave evaporation methods. The former use low energy waves that cause no physical or chemical changes in the substance, whereas the latter use high-energy waves to evaporate the water. The major advantage of these methods is that they are capable of rapidly determining the moisture content of a substance with little or no sample preparation and are therefore particularly useful for quality control purposes or rapid measurements of many samples.

### **Water Absorption**

Water absorption is a phenomenon in the transmission of electromagnetic radiation through a medium containing water molecules. Water molecules are excited by radiation at certain wavelengths and tend to selectively absorb portions of the spectrum while allowing the balance of the spectrum to be transmitted with minimal effect.

Strong water vapor absorption bands occur at wavelengths around 2500, 1950 and 1450 nanometers (nm), with weaker absorption around 1200 and 970 nm, and three additional sets of water-vapor absorption lines near 930, 820, and 730 nm, all in the infrared spectrum. Water has a complex absorption spectrum — the 2007 HITRAN spectroscopy database update lists more than 64,000 spectral lines corresponding to significant transitions of water vapor ranging from the microwave region to the visible spectrum.

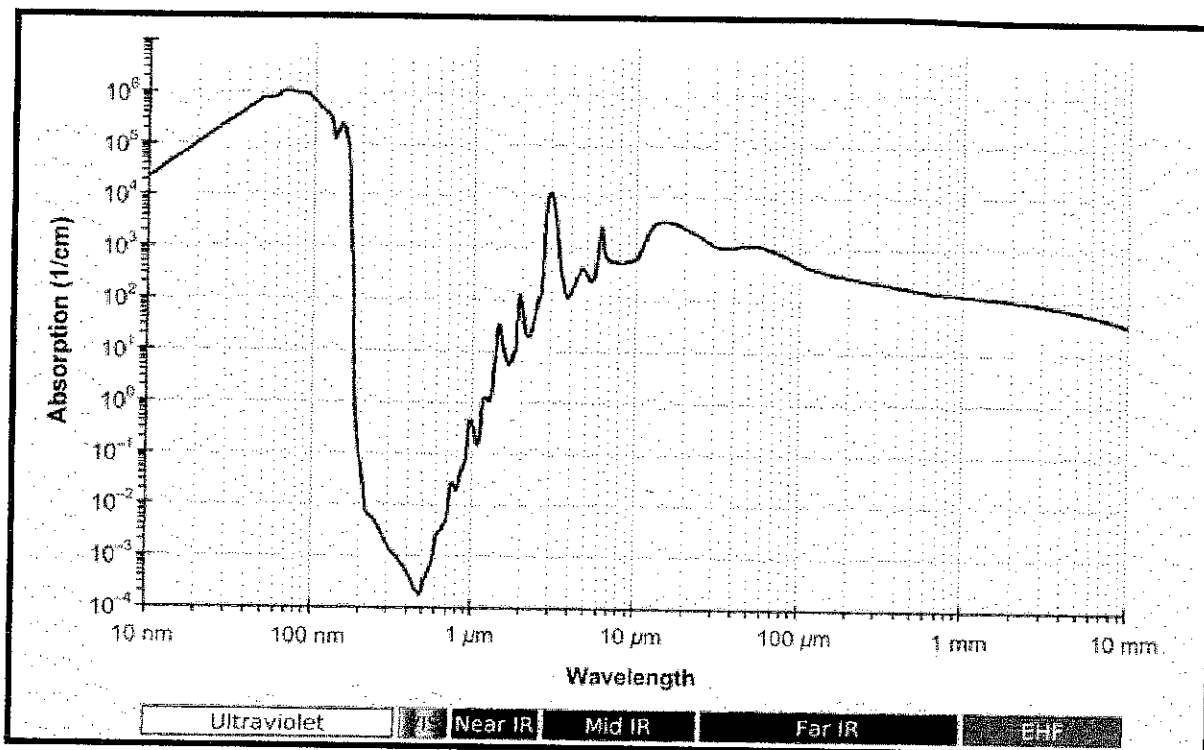

**Figure 2: Water absorption spectrum across a wide wavelength range.**

### Absorption Spectroscopy

Absorption spectroscopy refers to a range of techniques employing the interaction of electromagnetic radiation with matter. (Spectroscopy is a word that has come to denote an even wider variety of techniques used in physics and chemistry.) In absorption spectroscopy, the intensity of a beam of light measured before and after interaction with a sample is compared. When combined with the word spectroscopy, the words transmission and remission refer to the direction of travel of the beam measured after absorption to that before. The descriptions of the experimental arrangement usually assume that there is a unique direction of light incident upon the sample, and that a plane perpendicular to this direction passes through the sample. Light that is scattered from the sample toward a detector on the opposite side of the sample is said to be detected in transmission and treated according to the theory of transmission spectroscopy. Light that is scattered from the sample toward a detector on the same side of the sample is said to be

detected in remission and it is this light that is the subject of remission spectroscopy. The remitted radiation may be composed of two kinds of radiation referred to as specular reflection (when the angle of reflection is equal to the angle of incidence) and diffuse reflection (at all other angles).

Another descriptor associated with absorption spectroscopy is the wavelength range of the radiation being used in the incident beam. Infrared spectroscopy, near infrared spectroscopy, microwave spectroscopy, all are examples of absorption spectroscopy.

### **Spectroscopy as an analytical tool**

Often it is of interest to know not only the chemical composition of a given sample, but also the relative concentrations of the several compositing compounds. To do this, a scale, or calibration curve, must be constructed using several known concentrations for each compound of interest. The resulting plot of concentration vs. absorbance is fit either by hand or using appropriate curve-fitting software, yielding a mathematical formula to determine the concentration in the sample. Repeating this process for each compound in a sample gives a model of several absorption spectra added together to reproduce the observed absorption. In this way it is possible, for instance, to measure the chemical composition of comets without actually bringing samples back to Earth.

A simple example: a cyanide standard at 200 parts per million gives an absorbance with an arbitrary value of 1540. An unknown sample gives a value of 834. The math could be stated as: "if 200 give you 1540, what gives you 834?" Since this is a linear relation and goes through the origin, the unknown is easily calculated to be 108 parts per million. Note the beauty of the ratio method in that it is not necessary to know the values of the governing coefficients, or chromophores, or the experimental cell length - it all divides out.

In practice, use of a calibration curve rather than a single point of comparison reduces uncertainty in the final measurement by excluding random interference (noise) in the preparation of the standards.

---

### 3.2.1 Ultraviolet-visible Spectroscopy (UV-Visible)

**Ultraviolet-visible spectroscopy** or **ultraviolet-visible spectrophotometry (UV/ VIS)** involves the spectroscopy of photons in the UV-visible region. It uses light in the visible and adjacent near ultraviolet (UV) and near infrared (NIR) ranges. In this region of the electromagnetic spectrum, molecules undergo electronic transitions. This technique is complementary to fluorescence spectroscopy, in that fluorescence deals with transitions from the excited state to the ground state, while absorption measures transitions from the ground state to the excited state.

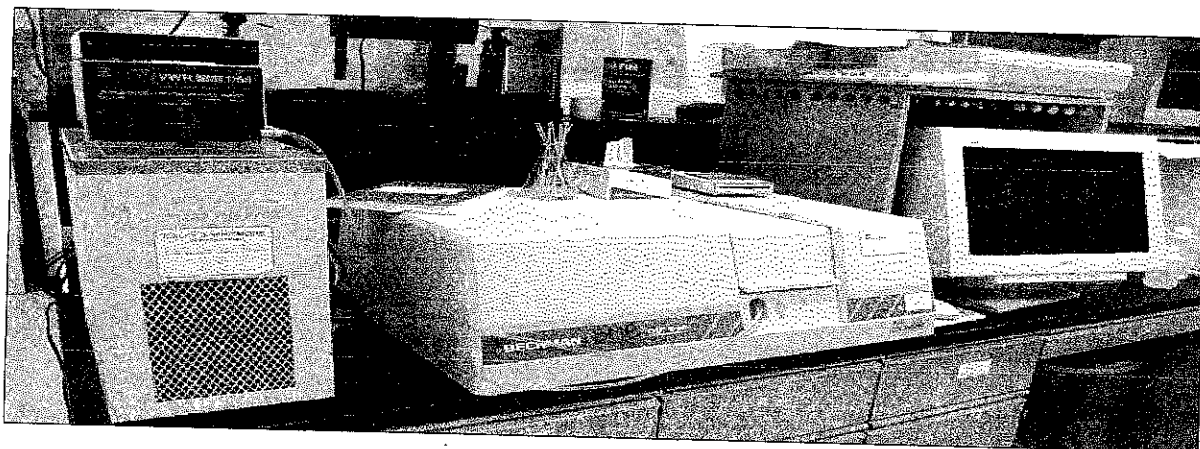

**Figure 3: DU640 spectrophotometer**

#### **Applications**

UV/Vis spectroscopy is routinely used in the quantitative determination of solutions of transition metal ions and highly conjugated organic compounds.

- Solutions of transition metal ions can be colored (i.e., absorb visible light) because d electrons within the metal atoms can be excited from one electronic state to another. The color of metal ion solutions is strongly affected by the

presence of other species, such as certain anions or ligands. For instance, the color of a dilute solution of copper sulfate is a very light blue; adding ammonia intensifies the color and changes the wavelength of maximum absorption ( $\lambda_{max}$ ).

- Organic compounds, especially those with a high degree of conjugation, also absorb light in the UV or visible regions of the electromagnetic spectrum. The solvents for these determinations are often water for water soluble compounds, or ethanol for organic-soluble compounds. (Organic solvents may have significant UV absorption; not all solvents are suitable for use in UV spectroscopy. Ethanol absorbs very weakly at most wavelengths.) Solvent polarity and pH can effect the absorption spectrum of an organic compound. Tyrosine, for example, increases in absorption maxima and molar extinction coefficient when pH increases from 6 to 13 or when solvent polarity decreases.
- While charge transfer complexes also give rise to colors, the colors are often too intense to be used for quantitative measurement.

The Beer-Lambert law states that the absorbance of a solution is directly proportional to the solution's concentration. Thus UV/VIS spectroscopy can be used to determine the concentration of a solution. It is necessary to know how quickly the absorbance changes with concentration. This can be taken from references (tables of molar extinction coefficients), or more accurately, determined from a calibration curve.

A UV/Vis spectrophotometer may be used as a detector for High-performance liquid chromatography (HPLC). The presence of an analyte gives a response which can be assumed to be proportional to the concentration. For accurate results, the instrument's response to the analyte in the unknown should be compared with the response to a standard; this is very similar to the use of calibration curves. The response (e.g., peak height) for a particular concentration is known as the response factor.

### **Beer-Lambert law**

The method is most often used in a quantitative way to determine concentrations of an absorbing species in solution, using the Beer-Lambert law:

$$A = -\log_{10}(I/I_0) = \epsilon \cdot c \cdot L,$$

where A is the measured absorbance,  $I_0$  is the intensity of the incident light at a given wavelength, I is the transmitted intensity, L the pathlength through the sample, and c the concentration of the absorbing species. For each species and wavelength,  $\epsilon$  is a constant known as the molar absorptivity or extinction coefficient. This constant is a fundamental molecular property in a given solvent, at a particular temperature and pressure, and has units of  $l / M \cdot cm$  or often AU / M \* cm.

The absorbance and extinction  $\epsilon$  are sometimes defined in terms of the natural logarithm instead of the base-10 logarithm.

The Beer-Lambert Law is useful for characterizing many compounds but does not hold as a universal relationship for the concentration and absorption of all substances. A 2nd order polynomial relationship between absorption and concentration is sometimes encountered for very large, complex molecules such as organic dyes (Xylenol Orange or Neutral Red, for example).

---

### 3.3 Thermal Analysis

Thermal analysis is a branch of materials science where the properties of materials are studied as they change with temperature.

Among all of the techniques available, Thermogravimetric Analysis (TGA) and Differential Scanning Calorimetry (DSC) are two of thermal analysis that has been chosen as their instruments are available in UTP's laboratories facilities. These two are available in Material (Mechanical) Laboratory.

#### 3.3.1 Thermogravimetric Analysis (TGA)

**Thermogravimetric Analysis** or **TGA** is a type of testing that is performed on samples to determine changes in weight in relation to change in temperature. Such analysis relies



on a high degree of precision in three measurements: weight, temperature, and temperature change. As many weight loss curves look similar, the weight loss curve may require transformation before results may be interpreted. A derivative weight loss curve can be used to tell the point at which weight loss is most apparent. Again, interpretation is limited without further modifications and deconvolution of the overlapping peaks may be required.

TGA is commonly employed in research and testing to determine characteristics of materials such as polymers, to determine degradation temperatures, *absorbed moisture content of materials*, the level of inorganic and organic components in materials, decomposition points of explosives, and solvent residues. It is also often used to estimate the corrosion kinetics in high temperature oxidation.

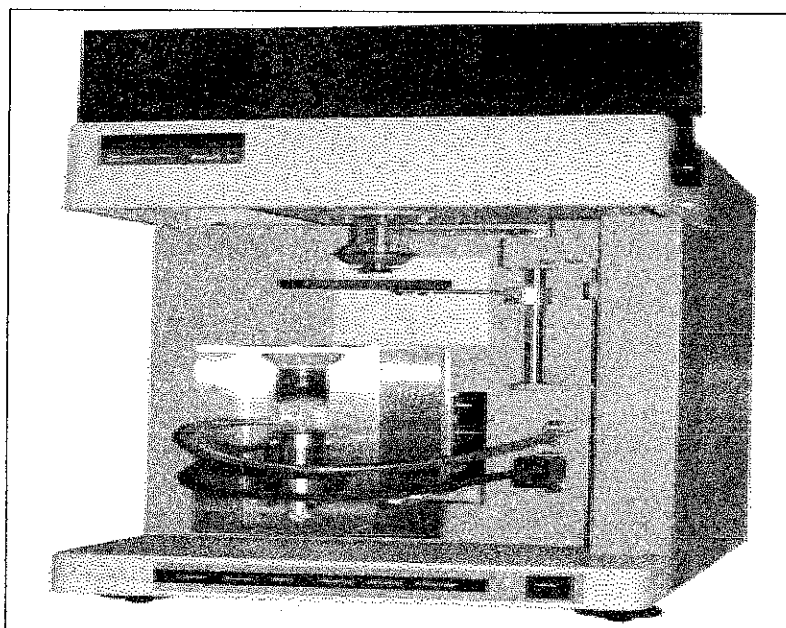

**Figure 4: Example of Thermogravimetric analyser**

### **Analyzer**

The analyzer usually consists of a high-precision balance with a pan (generally platinum) loaded with the sample. The pan is placed in a small electrically heated oven with a

thermocouple to accurately measure the temperature. The atmosphere may be purged with an inert gas to prevent oxidation or other undesired reactions. A computer is used to control the instrument.

Analysis is carried out by raising the temperature gradually and plotting weight against temperature. The temperature in many testing methods routinely reaches 1000°C or greater, but the oven is so greatly insulated that an operator would not be aware of any change in temperature even if standing directly in front of the device. After the data is obtained, curve smoothing and other operations may be done such as to find the exact points of inflection.

A method known as hi-res TGA is often employed to obtain greater accuracy in areas where the derivative curve peaks. In this method, temperature increase slows as weight loss increases. This is done so that the exact temperature at which a peak occurs can be more accurately identified. Several modern TGA devices can vent burnoff to a fourier-transform infrared spectrophotometer to analyze composition.

From Introduction to *Thermal Analysis* by Michael E. Brown;

Thermogravimetry is a measurement of changes in sample mass with temperature which is made using a thermobalance (or thermogravimetric analyzer). (Note that mass is a measure of the amount of matter in a sample, whereas weight refers to the effect of the gravitational force on a mass and thus varies from one geographical location another).

A thermobalance is a combination of a suitable electronic microbalance with a furnace, a temperature programmer and a computer for control that allows the sample to be simultaneously weighed and heated or cooled in a controlled manner, and the mass, time, temperature data to be captured.

The balance should be in a suitably enclosed system so that the nature and pressure of the atmosphere of the atmosphere surrounding the sample can be controlled.

### **The sample**

Although solid samples may be nominally of the same chemical composition, there may be considerable differences in their behavior on heating which arise from structural differences in the solid, such as the defect content, the porosity and the surface properties, which are dependent on the way in which the sample is prepared and treated after preparation.

In another reference found from anasys Methods Consultancy website:

### **Introduction to Thermogravimetry**

In this technique (TG or TGA), changes in the mass of a sample are studied while the sample is subjected to a controlled temperature programme. The temperature programme is most often a linear increase in temperature, but isothermal studies can also be carried out, when the changes in sample mass with time are followed. (There is also a family of newer control techniques - i.e. Controlled Rate methods, and Hi-Res™ TG, described elsewhere.)

The main processes amenable to study are listed below.

**Table 3: Processes amenable to study in TGA**

Process	Weight gain	Weight loss
Ad- or absorption	*	
Desorption		*
Dehydration/desolvation		*
Sublimation		*
Vaporization		*
Decomposition		*
Solid-solid reactions		*
Solid-gas reactions	*	*

TG is inherently quantitative, and therefore an extremely powerful thermal technique, but gives no direct chemical information. The ability to analyse the volatile products during a weight loss is of great value.

## Factors affecting the TG curve

Many factors influence the form of the TG curve, both sample- and instrument-related, some of which are interactive. The primary factors are heating rate and sample size, an increase in either of which tends to increase the temperature at which sample decomposition occurs, and to decrease the resolution between successive mass losses. The particle size of the sample material, the way in which it is packed, the crucible shape, and the gas flow rate can also affect the progress of the reaction. Careful attention to consistency in experimental details normally results in good repeatability. On the other hand, studying the effect of deliberate alterations in such factors as the heating rate can give valuable insights into the nature of the observed reactions.

TG has been applied extensively to studying analytical precipitates for gravimetric analysis. One example is that of calcium oxalate monohydrate, as shown below. This material has become popular for demonstrating thermobalance performance, as it gives three distinct weight losses over a wide temperature range.

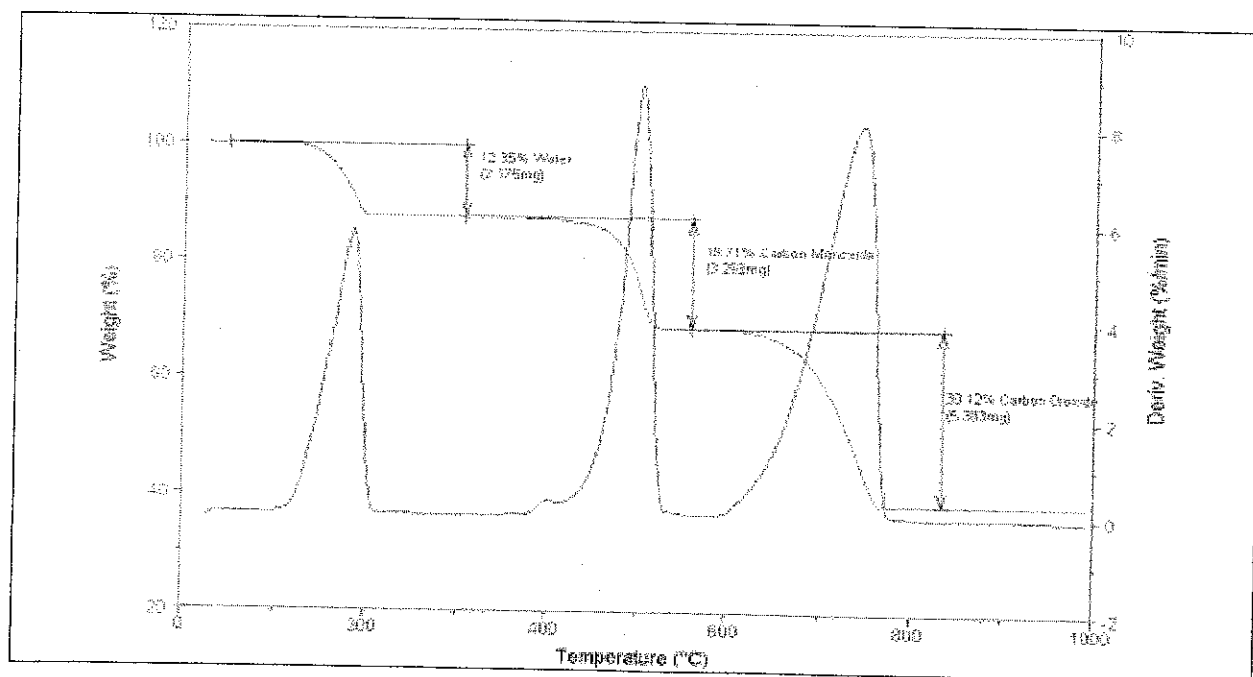

Figure 5: Example of TGA Plot

The plot also shows the derivative of the TG curve, or the DTG curve, which is often useful in revealing extra detail, such as the small event around 400°C, which would not have been seen on the TG curve itself. The DTG curve is sometimes used to determine inflection points on the TG curve, to provide reference points for weight change measurements in systems where the weight losses are not completely resolved.

### **Applications**

The ability of TG to generate fundamental quantitative data from almost any class of materials, has led to its widespread use in every field of science and technology. One of the key application areas which may be related to determination of water content in organic crude oil:

- **Compositional analysis:** by careful choice of temperature programming and gaseous environment, many complex materials or mixtures may be analyzed by selectively decomposing or removing their components. This approach is regularly used to analyze e.g. filler content in polymers; carbon black in oils; ash and carbon in coals, and the moisture content of many substances.

### **3.3.2 Differential Scanning Calorimetry**

**Differential scanning calorimetry** or **DSC** is a thermoanalytical technique in which the difference in the amount of heat required to increase the temperature of a sample and reference are measured as a function of temperature. Both the sample and reference are maintained at nearly the same temperature throughout the experiment. Generally, the temperature program for a DSC analysis is designed such that the sample holder temperature increases linearly as a function of time. The reference sample should have a well-defined heat capacity over the range of temperatures to be scanned.

The main application of DSC is in studying phase transitions, such as melting, glass transitions, or exothermic decompositions. These transitions involve energy changes or heat capacity changes that can be detected by DSC with great sensitivity.

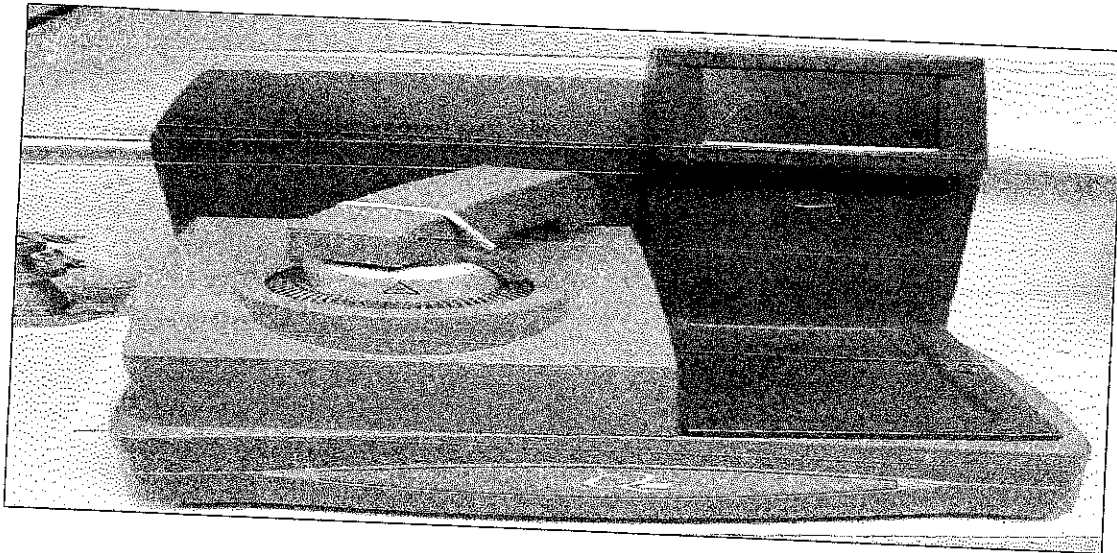

**Figure 6: Example of Differential Scanning Calorimeter**

### **Detection of phase transitions**

The basic principle underlying this technique is that, when the sample undergoes a physical transformation such as phase transitions, more or less heat will need to flow to it than the reference to maintain both at the same temperature. Whether more or less heat must flow to the sample depends on whether the process is exothermic or endothermic.

For example, as a solid sample melts to a liquid it will require more heat flowing to the sample to increase its temperature at the same rate as the reference. This is due to the absorption of heat by the sample as it undergoes the endothermic phase transition from solid to liquid. Likewise, as the sample undergoes exothermic processes (such as crystallization) less heat is required to raise the sample temperature. By observing the difference in heat flow between the sample and reference, differential scanning calorimeters are able to measure the amount of heat absorbed or released during such transitions. DSC may also be used to observe more subtle phase changes, such as glass transitions. DSC is widely used in industrial settings as a quality control instrument due to its applicability in evaluating sample purity and for studying polymer curing.

## DSC curves

The result of a DSC experiment is a curve of heat flux versus temperature or versus time. There are two different conventions: exothermic reactions in the sample shown with a positive or negative peak; it depends by the different kind of technology used by the instrumentation to make the experiment. This curve can be used to calculate enthalpies of transitions. This is done by integrating the peak corresponding to a given transition. It can be shown that the enthalpy of transition can be expressed using the following equation:

$$\Delta H = KA$$

where  $\Delta H$  is the enthalpy of transition,  $K$  is the calorimetric constant, and  $A$  is the area under the curve. The calorimetric constant will vary from instrument to instrument, and can be determined by analyzing a well-characterized sample with known enthalpies of transition.

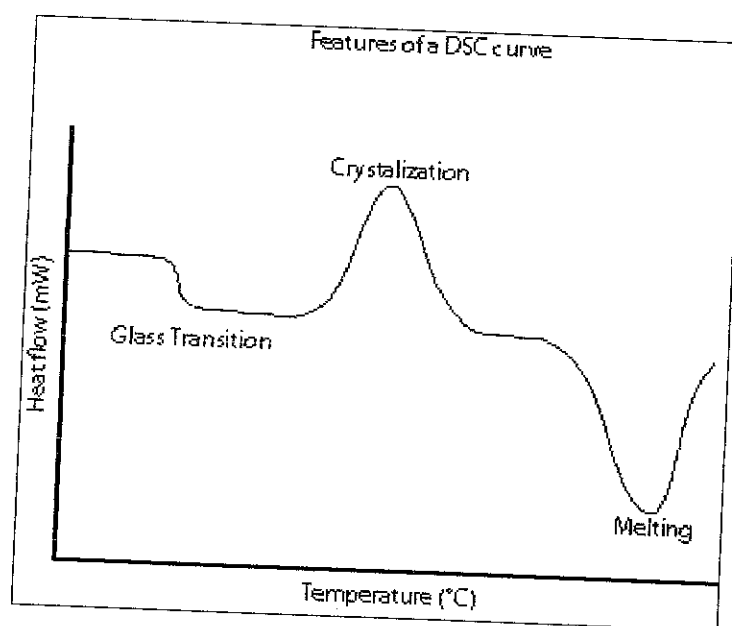

**Figure 7: A schematic DSC curve demonstrating the appearance of several common features**

From Introduction to *Thermal Analysis* by Michael E. Brown;

The aim of DSC is to maintain sample and a reference material at the same temperature ( $\Delta T = T_s - T_r = 0$ ) throughout the controlled temperature program where  $T_s$  is sample temperature while  $T_r$  is reference temperature. Difference in the independent supplies of power to sample and reference recorded against programmed (reference) temperature.

In another reference found from analysis Methods Consultancy website:

Most DSC instruments are of the heat-flux design, a schematic of which is shown below. There is another type of instrument, "power-compensated DSC", which is discussed in standard texts, and for most practical purposes gives equivalent results to good heat-flux designs. The figure most closely resembles the TA Instruments design of cell, but the features are common to most. Small, flat samples are contained in shallow pans, with the aim of making a good thermal contact between sample, pan and heat flux plate. Symmetrical heating of the cell, and therefore **S** and **R**, is achieved by constructing the furnace from a metal of high thermal conductivity - silver in the case of the TA Instruments design. Note the provision for establishing a gas flow through the cell, to sweep away volatiles, provide the required atmosphere, and to assist in heat transfer.

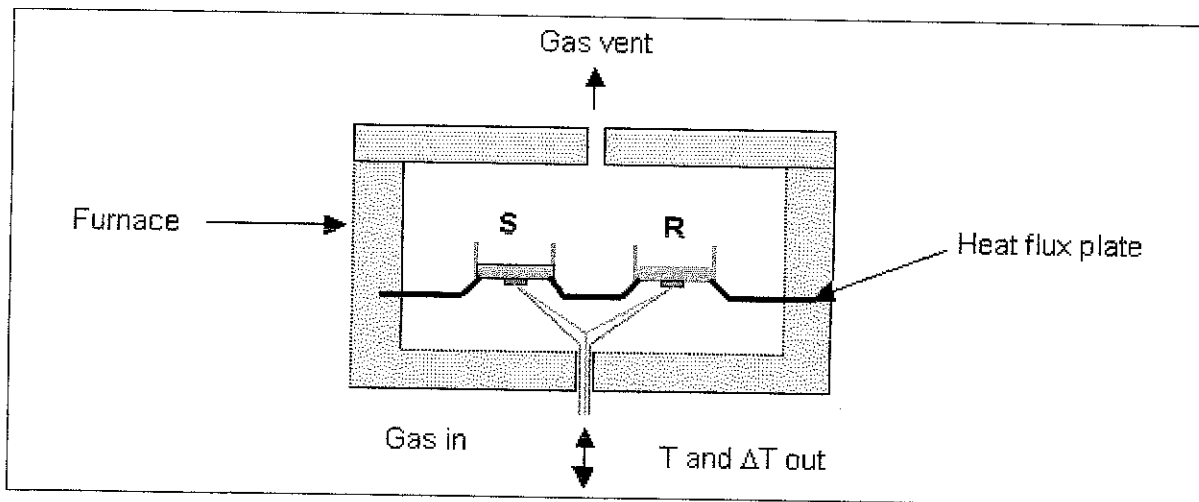

**Figure 8: DSC Apparatus (S=sample;R=reference)**

The control of the furnace, signal acquisition, and data storage and analysis are of course handled by a computer.



Temperature calibration is carried out by running standard materials, usually very pure metals with accurately known melting points. Energy calibration may be carried out by using either known heats of fusion for metals, commonly indium, or known heat capacities. Synthetic sapphire (corundum, or aluminium oxide) is readily available as a heat capacity standard, and the values for this have been accurately determined over a wide temperature range. The absolute accuracy for measurements of heat capacity and transformation enthalpies are more often limited by the lack of appropriate standards, and difficulties in assigning a baseline construction, than by limitations of the instrument itself.

Typical purge gases are air and nitrogen, though helium is useful for efficient heat transfer and removal of volatiles. Argon is preferred as an inert purge when examining samples that can react with nitrogen. The experiment can also be carried out under vacuum or under high pressure using instruments of the appropriate design.

### DSC Curve

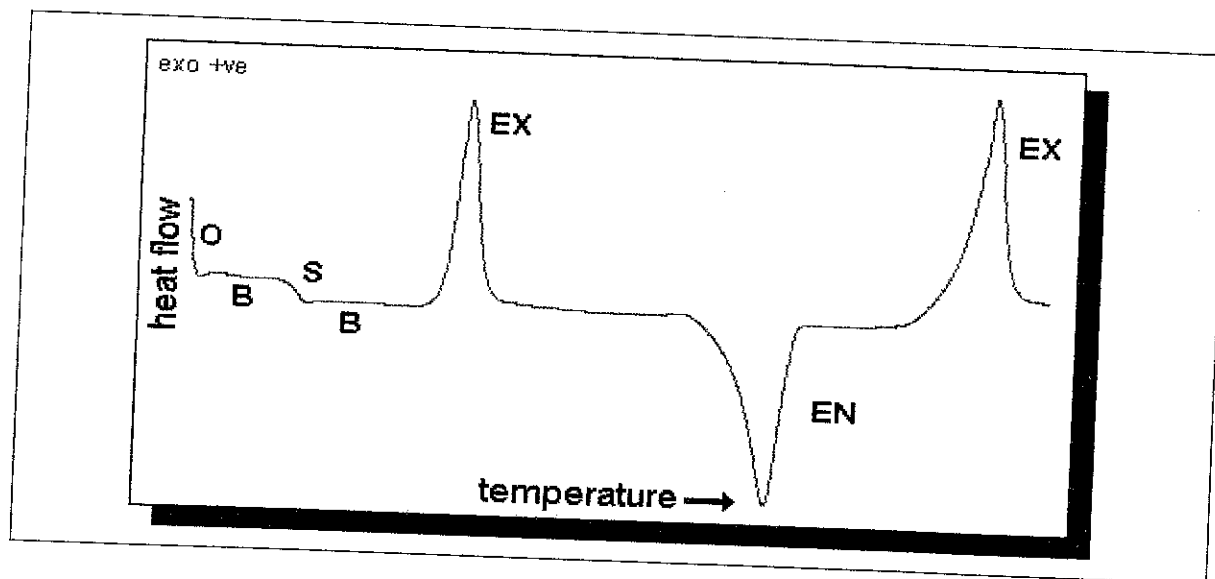

**Figure 9: DSC Curve**

The DSC curve above shows most of the general features likely to be encountered. At the start of heating, an offset, **O**, is usually apparent, which is due to an imbalance in the thermal capacities of the sample pan and its contents, and the reference pan and contents.

## **Heat Capacity Measurements**

In the absence of any discrete physical or chemical transformations, the baseline signal, as at **B** above, is related to the heat capacity of the sample. DSC allows this parameter to be determined with good accuracy over a wide temperature range. The conventional approach is to compare the signal obtained for the sample above that given by an empty pan, with the signal obtained for a standard material, usually sapphire, under the same conditions. Careful experimental technique is required to obtain accurate results, but heat capacities can be routinely measured to accuracies better than  $\pm 1\%$ .

Other techniques are available for heat capacity measurement by DSC. Accurate data can be obtained in narrow temperature intervals by using a non-equilibrium pulse technique, which is particularly useful when measurements need to be made in a region constrained by adjacent complicating transitions. Less time-consuming experiments than those described above can generate data more rapidly, but at the expense of accuracy and precision, which may be adequate for a given purpose. Modulated Temperature Differential Scanning Calorimetry (MTDSC), a recent enhancement of DSC, routinely generates  $C_p$  data from a standard experiment, and can in fact measure this in a nominally isothermal condition. The classical method above however is recommended for the best quality results.

## **Second Order Transitions**

The DSC/DTA curve may show a step change, as at **S** in the curve, reflecting a change in heat capacity not accompanied by a discrete enthalpy change. The most common example, and a major application area of DSC, is the glass transition ( $T_g$ ) seen in amorphous polymers. This important region, in which the material changes from a rigid glassy state to a rubber, or very viscous liquid state, may be analysed to give a wealth of information about the material.

The temperature  $T_g$  may be used to identify polymers, as it varies over a wide range for commonly used materials. The amount or effectiveness of a plasticiser may be judged by how much it reduces  $T_g$  or affects the shape of the transition. Examination of the

transitions in polymer blends gives information as to their compatibility. Curing reactions result in an increase in  $T_g$  and measurements can be used to monitor the extent of cure.  $T_g$  also varies with chain length for a related group of polymers. Additional features occurring in the glass transition region, often a superimposed endothermic peak, are related to the aging undergone by the material in the glassy state, and can sometimes obscure the transition, making precise temperature measurement difficult or futile. MTDSC offers considerable benefits in this respect, being able to separate the two effects.

A standardized technique is important for  $T_g$  measurements, as the measured values depend on the thermal history of the material. The  $T_g$  changes with the rate of cooling from the melt, and is therefore not a fixed value. For comparison purposes, it is common to record the event on first heating, melt the sample, cool at a chosen standard rate, and then reheat through the transition.

### **Enthalpy Changes**

The DSC/DTA curve may show an exothermic or endothermic peak, as at **EX** and **EN** in the curve above. The enthalpy changes associated with the events occurring are given by the area under the peaks. In general, the heat capacity will also change over the region, and problems may arise in the correct assignment of the baseline. In many cases the change is small, and techniques have been developed for reproducible measurements in specific systems.

Peaks may be characterized by:

1. Position (i.e., start, end, extrapolated onset and peak temperatures)
2. Size (related to the amount of material and energy of the reaction)
3. Shape (which can be related to the kinetics of the process)

Some possible processes giving enthalpic peaks are listed below.

**Table 4: Possible processes giving enthalpic peaks in DSC**

Process	Exotherm	Endotherm
Solid-solid transition	*	*
Crystallisation	*	
Melting		*
Vaporisation		*
Sublimation		*
Adsorption	*	
Desorption		*
Desolvation (drying)		*
Decomposition	*	*
Solid-solid reaction	*	*
Solid-gas reaction	*	*
Curing	*	
Polymerisation	*	
Catalytic reactions	*	

All of the methods mentioned above will be further discussed with lab technician whether it would be possible to use in determining water content in organic crude oil.

However, the first five test methods could not be done in UTP laboratories due to:

- UTP laboratories are not equipped with the instrument of Karl-Fischer Titrator.
- Fourier Transform Infrared Spectroscopy (FTIR) is not available for liquid sample; only for solid sample.
- The instrument for DSC broke down and still under maintenance. That is the only DSC instrument available here.
- TGA instrument is not feasible for usage of aqueous solution and the test is not recommended by lab technician, for the water content in the sample might damage the pan and lid.

Only UV-Visible Spectrometer is available for spectroscopy method. Thus only this test method is done

#### 4.0 METHODOLOGY

A thorough search was made through the internet and from the libraries to collect all available information on the methods for better understanding in order to come out with the suitable experimental procedures and to make sure the equipments and chemicals are available and easy to get. As mentioned, only UV-Visible Test is available.

Originally, the method suggested, an organic substance sample (acetonitrile) will be used first before the organic crude oil. The organic substance will be added with 7 different ratios of water and the results from all those ratios will be used to prepare the calibration curves. Later, the organic crude oil will be tested with all those methods and the water content can be obtained from the calibration curves from each method. But in the absence of organic oil, results of the analysis will be discussed whether the test is suitable for further studies in determining soluble water content in organic oil or not.

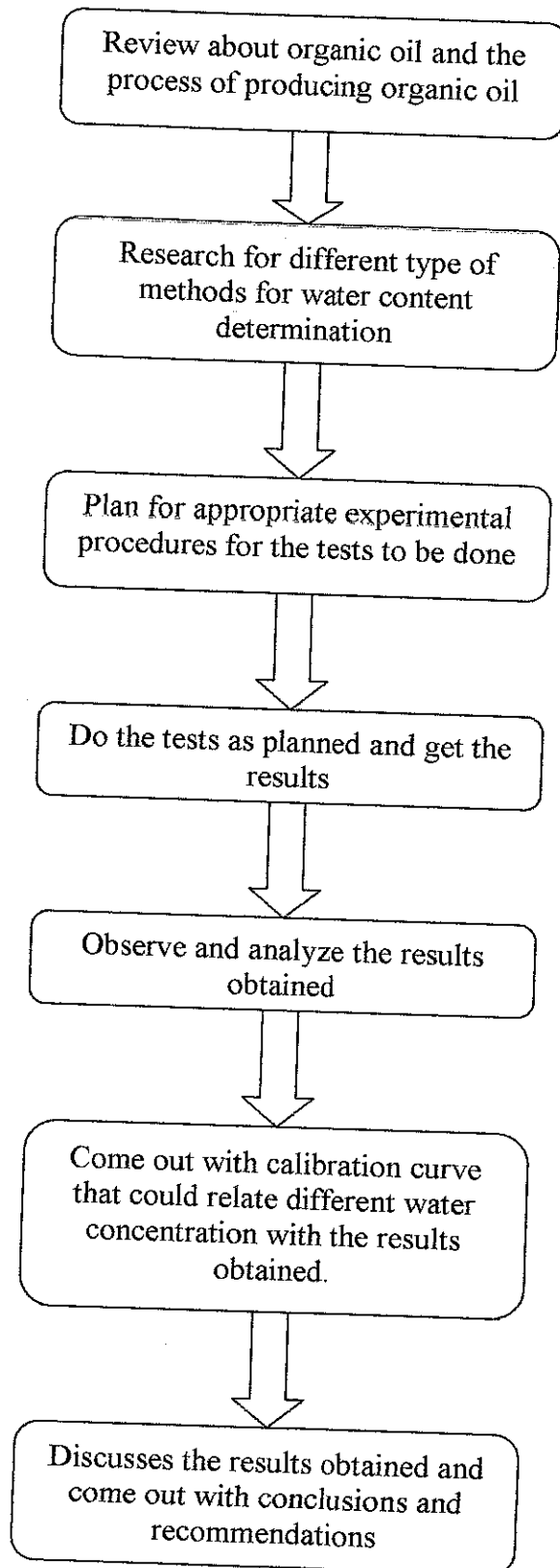

**Figure 10: Flow of Project Activities**



## 5.0 EXPERIMENTAL PROCEDURES

### 5.1 UV/ VIS Spectrometry Method

#### 5.1.1 Basic experimental procedures:

The instrument used in UV/ VIS spectroscopy is called a UV/ VIS **spectrophotometer**. Generally, to obtain absorption information:

1. A sample is placed in the spectrophotometer and ultraviolet and/or visible light at a certain wavelength (or range of wavelengths) is shined through the sample.
2. The spectrophotometer measures how much of the light is absorbed by the sample. The intensity of light before going into a certain sample is symbolized by  $I_0$ . The intensity of light remaining after it has gone through the sample is symbolized by  $I$ .
3. The fraction of light transmittance is  $I/ I_0$ , which is usually expressed as a percent Transmittance (%T). From this information, the absorbance of the sample is determined for that wavelength or as a function for a range of wavelengths. Sophisticated UV/ Vis spectrophotometers often do this automatically.
4. Although the samples could be solid (or even gaseous), they are usually liquid. A transparent cell, often called a *cuvette*, is used to hold a liquid sample in the spectrophotometer.
5. The pathlength  $L$  through the sample is then the width of the cell through which the light passes through. Simple (economic) spectrophotometers may use cuvettes shaped like cylindrical test tubes, but more sophisticated ones use rectangular cuvettes, commonly 1 cm in width. For just visible spectroscopy, ordinary glass cuvettes may be used, but ultraviolet spectroscopy requires special cuvettes made of a UV-transparent material such as quartz.



### 5.1.2 How UV-Visible Works

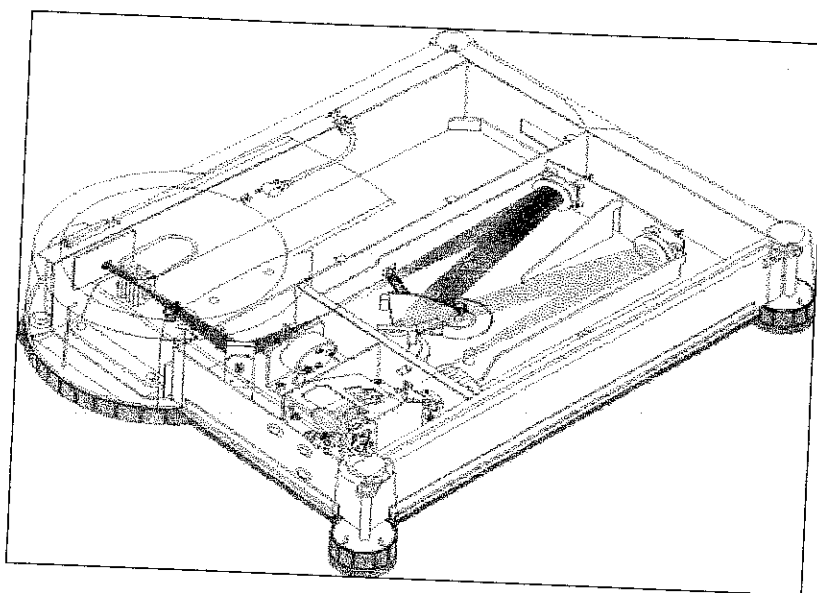

**Figure 11: Diagram of a UV/Visible spectrometer**

Ultraviolet spectrometers consist of a light source, reference and sample beams, a monochromator and a detector. The ultraviolet spectrum for a compound is obtained by exposing a sample of the compound to ultraviolet light from a light source, such as a Xenon lamp.

The reference beam in the spectrometer travels from the light source to the detector without interacting with the sample. The sample beam interacts with the sample exposing it to ultraviolet light of continuously changing wavelength. When the emitted wavelength corresponds to the energy level which promotes an electron to a higher molecular orbital, energy is absorbed. The detector records the ratio between reference and sample beam intensities ( $I_0/I$ ). At the wavelength where the sample absorbs a large amount of light, the detector receives a very weak sample beam. Once intensity data has been collected by the spectrometer, it is sent to the computer as a ratio of reference beam and sample beam intensities. The computer determines at what wavelength the sample absorbed a large amount of ultraviolet light by scanning for the largest gap between the two beams.

When a large gap between intensities is found, where the sample beam intensity is significantly weaker than the reference beam, the computer plots this wavelength as having the highest ultraviolet light absorbance when it prepares the ultraviolet absorbance spectrum.

### 5.1.3 Beer-Lambert Law

The method is used in a quantitative way to determine concentrations of an absorbing species in solution, using the Beer-Lambert law:

$$A = -\log_{10}(I/I_0) = \epsilon \cdot c \cdot L$$

where  $A$  is the measured absorbance,  $I/I_0$  is the intensity of the incident light at a given wavelength,  $I$  is the transmitted intensity,  $L$  the pathlength through the sample, and  $c$  the concentration of the absorbing species. For each species and wavelength,  $\epsilon$  is a constant known as the extinction coefficient.

The absorbance  $A$  and extinction  $\epsilon$  are sometimes defined in terms of the natural logarithm instead of the base-10 logarithm.

Below are the assumed experimental procedures for UV-Visible Spectrometry Method based from the 'experimental procedures for UV-visible spectrometer to explore and identify the concentration of metal ions in solution'.

### 5.1.5 Essential Components of a UV-visible Spectrometer

A UV-visible spectrometer is a device that detects how much light is absorbed by an ion (or molecule) of interest. Notice that in the space below are three rectangular boxes in a linear row. Label below the **first** rectangle "Light Source", below the **second** rectangle "Sample Compartment" and below the **third** rectangle "Detector". When the light source is turned on, light travels from the light source through the sample compartment to the detector.

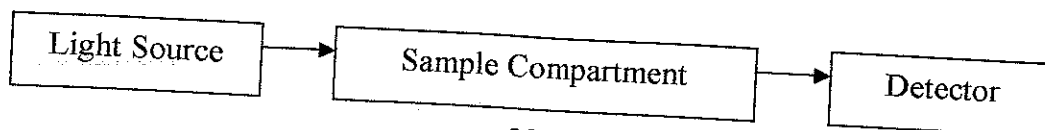

### 5.1.6 Taking an instrumental blank.

Typically, a glass or plastic container called a cuvet is used to hold a solution that contains one or more types ions (or molecules) of interest. Polystyrene, quartz, and borosilicate (Pyrex) cells are the most currently used as the cuvetts. UV light is absorbed by most glasses and plastics, so quartz cells are used. Since the cuvet and solvent are not of interest, a cuvet with just solvent is placed in the sample compartment and the amount of light arriving at the detector is determined. This is called taking an instrumental blank and it is used to establish a baseline for how much light passes through the sample compartment without a sample being present.

### 5.1.7 Taking a UV-visible spectroscopy scan.

The instrumental blank is electronically stored by the instrument and is then subtracted whenever a sample is introduced into the cuvet and a SCAN is taken by the instrument. If after an instrumental blank is taken, and immediately a SCAN is taken without introducing any ions (or molecules) into the cuvet, the light getting to the detector minus the instrumental blank would basically give zero response (there would however be some noise).

Now the rectangles below in the same fashion as in part a, but added inside the second rectangle the word "Sample". **If the sample absorbed light, what would happen to the amount of light getting to the detector compared to the instrumental blank?**

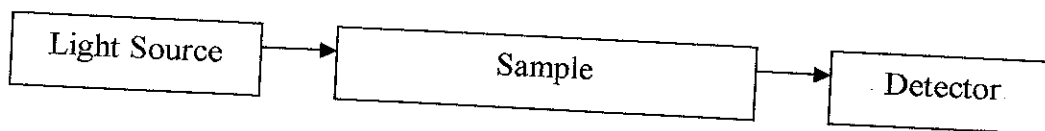

For example, consider the UV-visible spectrum below of a metal ion. The two peaks observed in the spectrum are the result of absorption of light at two different

wavelengths (around 250 nm and around 400 nm). Because of the absorption of light by the metal ion, the amount of light getting to the detector **decreases**, yet the absorbances are shown in the graph **increases** (shown as positive peaks).

### Why?

According to absorption spectroscopy theory, the intensity of a beam of light measured before and after interaction with a sample is compared. When combined with the word spectroscopy, the words transmission and remission refer to the direction of travel of the beam measured after absorption to that before. The descriptions of the experimental arrangement usually assume that there is a unique direction of light incident upon the sample, and that a plane perpendicular to this direction passes through the sample. Light that is scattered from the sample toward a detector on the opposite side of the sample is said to be detected in transmission and treated according to the theory of transmission spectroscopy. Light that is scattered from the sample toward a detector on the same side of the sample is said to be detected in remission and it is this light that is the subject of remission spectroscopy. The remitted radiation may be composed of two kinds of radiation referred to as specular reflection (when the angle of reflection is equal to the angle of incidence) and diffuse reflection (at all other angles).

### 5.1.8 Standard Samples Preparation

Prepare 7 samples of acetonitrile with different with different soluble water content; different concentration with 20 ml basis for each sample:

**Table 6: Standard Samples Concentration**

Acetone concentration (vol%)	100	90	80	60	40	20	10
Label	A	B	C	D	E	F	G

<b>Acetone(ml)</b>	20	18	16	12	8	4	2
<b>Water(ml)</b>	0	2	4	8	12	16	18

### Procedures for UV-Visible

6. For start-up:
  - i. Turn on the instrument (UV-Vis NIR Spectrophotometer).
  - ii. Turn on the PC which is connected to the instrument and open UV-Probe program.
  - iii. Clicks connect at the bottom of the panel and a window test will pop up.
  - iv. Do baseline test where both of the cuvet (plastic or glass container used to hold a solution) empty from samples with wavelength ( $\lambda$ ) range from 190nm to 800nm. This is also called instrumental blank.
  
2. Use distilled water as reference or base and put it in the reference cuvet and do autozero test.
  
3. Do spectrum check to confirm at which wavelength range the sample would absorb. Set the range from 190nm to 800nm which is the minimum and maximum range for the instrument used. This step is unnecessary if the range is known.
  
4. Insert sample to be test in the sample cuvet and click start.
  
5. The instrument will come out with the absorbance vs. wavelength curve and the data for each peak will be shown in 'peak pick table'
  
7. Repeat step 4 for each samples and look for pick the suitable peak for all samples.

## 6.0 RESULTS AND DISCUSSION

### UV-VISIBLE TEST

For the full results of UV-Visible test, refer to Appendix.

#### Selection of wavelength for calibration curves

From the results obtained for all three tests with different bases, supposedly wavelength maxima (wavelength with the highest absorbance value) will be chosen. But in this study, since for all different tests, they are different wavelengths maxima for each test, thus a wavelength which have one of the picks situated there for each test is selected in order to make calibration curve which can relate the difference of water content in organic substance with absorbance value at a certain wavelength.

#### i) Water as base:

**Table 23: Wavelength Selection for Water as Base**

Sample(s)	Wavelength	Abs
E	234.5	1.556
D	234.9	1.981
C	237.2	0.099

From the above table, only these three samples have pick at an almost similar wavelength. Thus, this *result is ignored*.

#### ii) Acetonitrile as base:

**Table 24: Selection for Acetonitrile as Base at Wavelength=320 nm**

Sample(s)	Wavelength	Abs
B	320.0	-0.004
C	320.0	-0.006

<b>D</b>	320.0	-0.013
<b>E</b>	320.0	-0.016
<b>F</b>	320.0	-0.019
<b>G</b>	320.0	-0.020

Since all 5 samples tested give absorbance value at almost similar value of wavelength, calibration curve is plotted such as below:

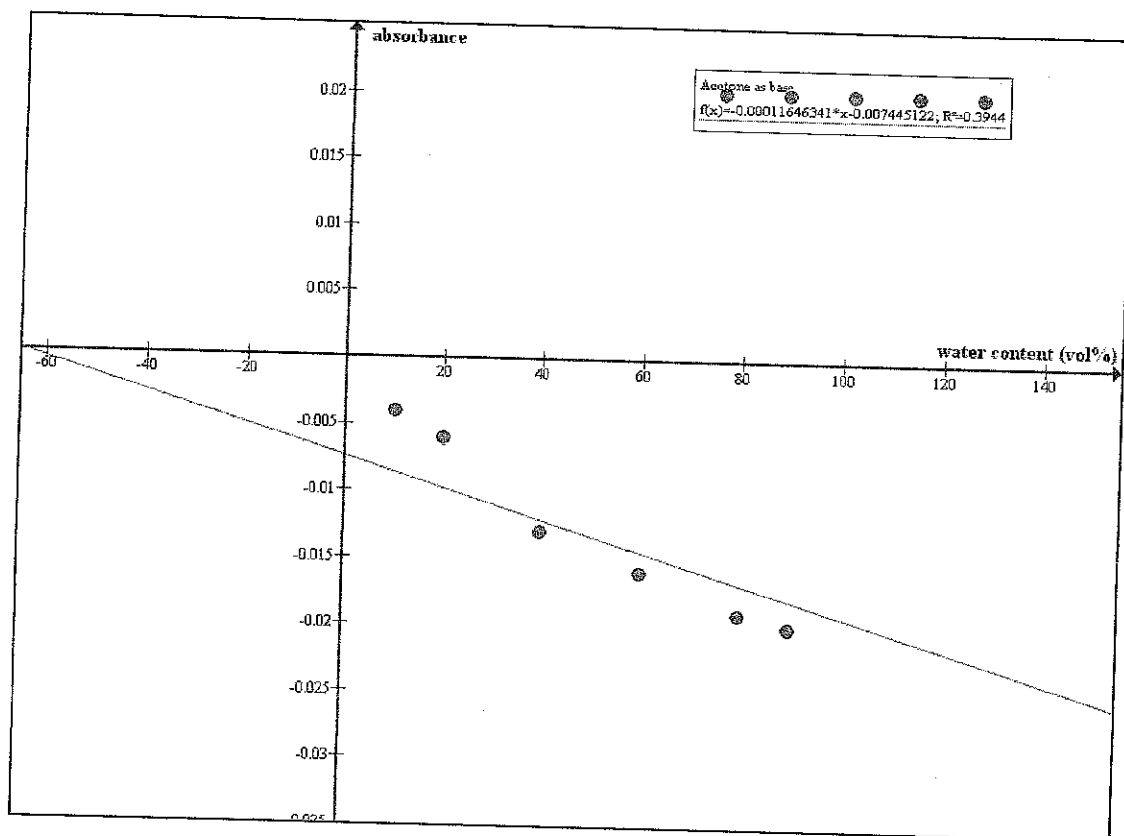

**Figure 29: Absorbance Vs Water Content (Vol %) At ~320 Nm of Wavelength (Acetonitrile as Base)**

Supposedly, absorbance value increases with concentration but the graph has negative slope since the absorbance value decreases along with the decrease in the concentration of acetonitrile (increase in water content). The negative value of the absorbance is resulted from the usage of 100% acetonitrile as the base. From Beer-Lambert Law,

$$\text{Absorbance} = -\log(I/I_0)$$

where  $I_0$  is the intensity of reference beam which is at the lowest since we have the concentration of the reference at the highest (high concentration; high absorbance). Thus when the test is done with the samples which have lower concentration, and resulting in lower absorbance; higher intensity of sample beam,  $I$ .

Mathematically the resulting  $(I/I_0)$  would be larger than one, thus negative log for  $(I/I_0) > 1$  will give negative value of absorbance.

iii) No base

**Table 25: Selection for No Base at Wavelength =260nm.**

Sample(s)	Wavelength	Abs
B	260.0	0.184
C	260.0	0.145
D	260.0	0.141
E	260.0	0.114
F	260.0	0.104
G	260.0	0.095



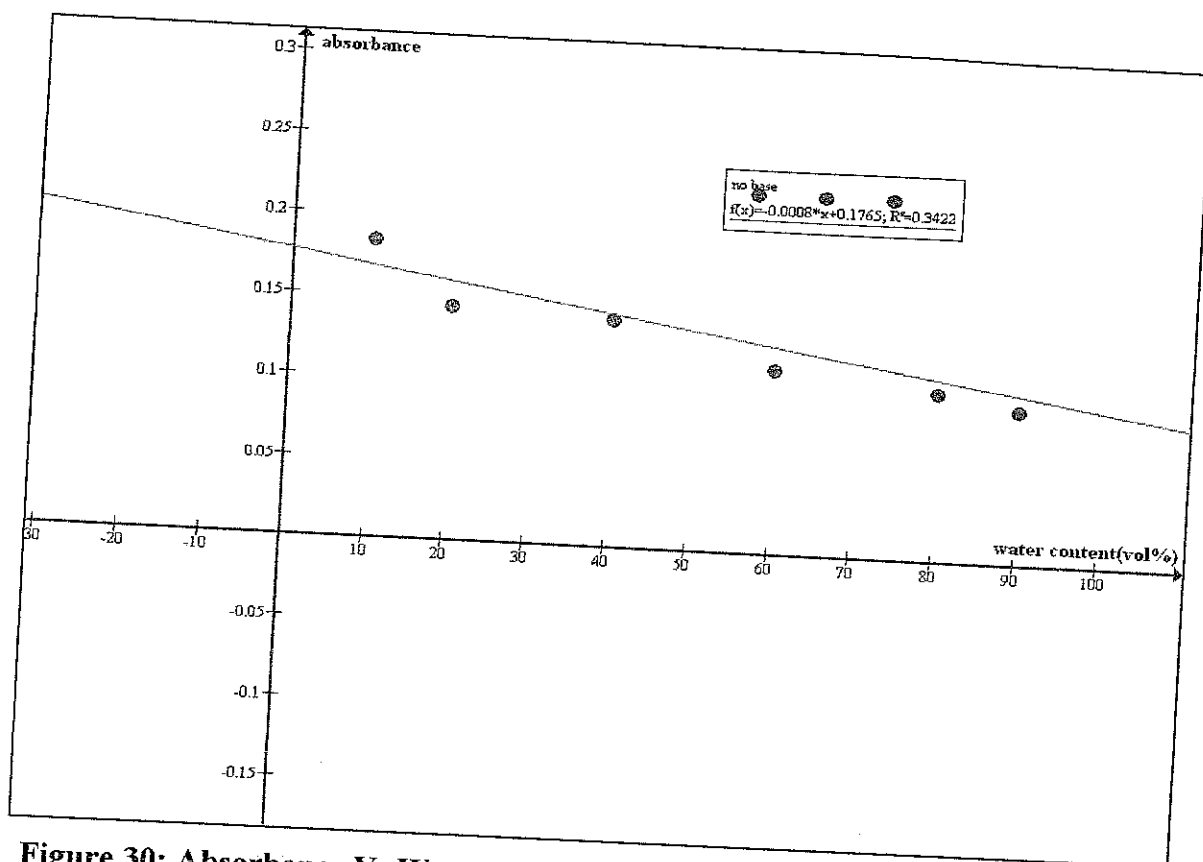

**Figure 30: Absorbance Vs Water Content (Vol %) At ~260 Nm of Wavelength (No Base)**

The graph above also has negative slope since the absorbance value decreases along with the decrease in the concentration of acetonitrile (increase in water content). Plus, water has no absorbance over the entire wavelength range from 1100 to 200 nm (good solvent for UV-visible) and acetone does not absorb at wavelength shorter than 220nm. While the instrument captures data from wavelength range between 200 nm and 800 nm, thus the absorbance values are solely from acetonitrile.

Thus in order to confirm the above assumption, the test with no base is done and it can be observed that the gradient of the line is negative, only that it gives positive values of absorbance. This is because the absorbance values solely from the samples tested, not from being compared to any base sample.

When using organic oil with unknown concentration, the result will differ since organic oil has different kind substances in it such as shown in the table below:

**Table 26: Properties of Bio-oil from Various Feedstocks**

Property	Birch	Pine	Poplar	Various
Solids (wt%)	0.06	0.03	0.045	0.01-1
PH	2.5	2.4	2.8	2.0-3.7
Water (wt%)	18.9	17.0	16.8	15-30
Density (kg/m <sup>3</sup> )	1.25	1.24	1.20	1.2-1.3
Viscosity, cSt @ 50°C	28	28	13.5	13-80
LHV (MJ/kg)	16.5	17.2	17.3	13-18
Ash (wt%)	0.004	0.03	0.007	0.004-0.3
CCR (wt%)	20	16	N/M	14-23
C (wt%)	44.0	45.7	48.1	32-49
H (wt%)	6.9	7.0	5.3	6.9-8.6
N (wt%)	<0.1	<0.1	0.14	0.0-0.2
S (wt%)	0.00	0.02	0.04	0.0-0.05
O (wt%)	49.0	47.0	46.1	44-60
Na + K (ppm)	29	22	2	5-500
Ca (ppm)	50	23	1	4-600
Mg (ppm)	12	5	0.7	N/M
Flash Point (°C)	62	95	64	50-100
Pour Point (°C)	-24	-19	N/M	-36 -9

Compared to acetonitrile, the difference that will most probably affect the absorbance results would be the appearance. Acetonitrile is a colorless liquid while organic oil is black in color. Other main properties of acetonitrile are listed as below:

**Table 27: Properties of Acetonitrile**

Properties	
Molecular formula	CH <sub>3</sub> CN
Molar mass	41.05 g/mol
Appearance	colorless liquid
Density	0.786 g/mL liquid
Melting point	-45 °C
Boiling point	82 °C
Solubility in water	miscible
Solubility	organic solvents
Acidity(pK <sub>a</sub> )	25

Acetonitrile is chosen for this project mainly because it is the easiest organic substance obtained in UTP. Plus, water is miscible in acetonitrile. It is not easy to get organic substance which is black in color and water miscible at the same time.

In addition, this project does not focus mainly on the results, but to investigate the applicability of the method used, which will be further studied to confirm whether the method would be suitable for soluble water content in organic oil or not.

Other than UV-Visible, spectroscopic method can also be done by other instrument. This is to see the difference in absorbance values obtained in different range of wavelength for different type of instruments for spectroscopy. The results can be compared with spectral data in the table below:

**Table 28: Spectral Data of Acetonitrile**

UV-Vis	
$\lambda_{\max}$	280 nm
Extinction coefficient, $\epsilon$	12.4 L/(mol·cm) @ 280 nm

**IR**

(liquid film)

**Wave number Transmittance**

Major absorption bands <sup>[4]</sup>	3414 cm <sup>-1</sup>	78%
	3005 cm <sup>-1</sup>	66%
	2966 cm <sup>-1</sup>	74%
	2925 cm <sup>-1</sup>	77%
	1749 cm <sup>-1</sup>	52%
	1715 cm <sup>-1</sup>	4%
	1434 cm <sup>-1</sup>	49%
	1421 cm <sup>-1</sup>	47%
	1363 cm <sup>-1</sup>	13%
	1223 cm <sup>-1</sup>	12%
	1093 cm <sup>-1</sup>	68%
	903 cm <sup>-1</sup>	81%
531 cm <sup>-1</sup>	36%	

## 7.0 CONCLUSION AND RECOMMENDATION

### 7.1 Conclusion

- Absorbance value decreases with higher water content -differ in absorption spectrum with organic oil.
- Possible to use this method by using standard samples with the most similar properties with organic oil.
- This project does not focus mainly on the results, but to investigate the applicability of the method used, which will be further studied to confirm whether the method would be suitable for soluble water content in organic oil or not.

The results obtained for UV-Visible Method shows that the absorbance value decreases with water content since absorbance decreases with the decrease in acetone concentration. But, if the test is done using organic oil, the result might differ since there are other components exist in it which might affect the absorbance values. Thus, it is possible to measure water content with this method by using calibration curve of standard organic samples with the most similar properties with organic oil.

Acetonitrile is chosen for this project mainly because it is the easiest organic substance obtained in UTP. Plus, water is miscible in acetonitrile .It is not easy to get organic substance which is black in color and water miscible at the same time.

In addition, this project does not focus mainly on the results, but to investigate the applicability of the method used, which will be further studied to confirm whether the method would be suitable for soluble water content in organic oil or not.

### 7.2 Suggestion Future Work for Expansion and Continuation

Due to limitation of analytical instruments (listed in Chapter 3.0) available for liquid sample in UTP and absence of organic oil sample itself, this project is only managed to be finished up to the calibration curve for UV-Visible Method.

However, other properties that might be affected from different concentration of water in organic substance and possible to be investigated but could not be done due to limitation of time are listed below:

- Electrical Conductivity
- Energy- with DSC (when the instrument is available)
- Polarity- Polarimetric Method
- Differential Index of Refraction

Other spectroscopic method can also be studied such as FTIR when the instrument is readily available again.

The studies should also be expanded by including bio-oil, thus the sample should be readied at earlier stage.

## 8.0 REFERENCES

### 8.1 Websites

- [1] <http://genting.listedcompany.com/misc/arGenting2006/ar200600041.html>
- [2] [http://en.wikipedia.org/wiki/Karl\\_Fischer\\_titration](http://en.wikipedia.org/wiki/Karl_Fischer_titration)
- [3] [http://en.wikipedia.org/wiki/Water\\_absorption](http://en.wikipedia.org/wiki/Water_absorption)
- [4] [http://en.wikipedia.org/wiki/Absorption\\_spectroscopy](http://en.wikipedia.org/wiki/Absorption_spectroscopy)
- [5] <http://www.anasys.co.uk/library/macrotta.htm>
- [6] [http://en.wikipedia.org/wiki/UV/VIS\\_spectroscopy](http://en.wikipedia.org/wiki/UV/VIS_spectroscopy)
- [7] [http://en.wikipedia.org/wiki/Thermal\\_analysis](http://en.wikipedia.org/wiki/Thermal_analysis)
- [8] [http://en.wikipedia.org/wiki/Differential\\_scanning\\_calorimetry](http://en.wikipedia.org/wiki/Differential_scanning_calorimetry)
- [9] [http://en.wikipedia.org/wiki/Thermogravimetric\\_analysis](http://en.wikipedia.org/wiki/Thermogravimetric_analysis)
- [10] <http://foodeng.wisc.edu/mamual/DSC%20instruction.pdf>
- [11] [UV/VIS spectroscopy - Facts, Information, and Encyclopedia Reference article](#)
- [12] [An Introduction to Ultraviolet-visible \(UV-vis\) Spectroscopy](#)
- [13] <http://www.umassd.edu/engineering/mtx/research/downloads/dsc.doc>
- [14] <http://linkinghub.elsevier.com/retrieve/pii/S0040603103003642>
- [15] <http://www.liebertonline.com/doi/pdf/10.1089/cpt.2006.9991>
- [16] <http://www.iop.org/EJ/article/0953-8984/12/44/311/c04411.ps.gz>
- [17] [http://www.jimmyhe.com/ne2201/exp\\_2.pdf](http://www.jimmyhe.com/ne2201/exp_2.pdf)
- [18] [[http://www.fisk.edu/~aburger/Published03\\_06/Measurement\\_Thermal/DSC\\_TGA/dsc\\_tga.html](http://www.fisk.edu/~aburger/Published03_06/Measurement_Thermal/DSC_TGA/dsc_tga.html)]
- [19] [[http://www.aist.go.jp/RIODB/SDBS/cgi-bin/cre\\_index.cgi](http://www.aist.go.jp/RIODB/SDBS/cgi-bin/cre_index.cgi) "Spectral Database for Organic Compounds"] (Queryable database). Advanced Industrial Science and Technology. [http://www.aist.go.jp/RIODB/SDBS/cgi-bin/cre\\_index.cgi](http://www.aist.go.jp/RIODB/SDBS/cgi-bin/cre_index.cgi). Retrieved on 7 June 2007.

### 8.2 Journals

- [1] Michael E. Brown, Second Edition, *Introduction to Thermal Analysis; Techniques and Applications*.

- [2] Jun Soo Kim, Myung Gil Choi, Youn Huh, Mi Hee Kim, So Hee Kim, Se Yeon Wang and Suk-Kyu Chang, *Determination of Water Content in Aprotic Organic Solvents Using 8-Hydroxyquinoline Based Fluorescent Probe*, Department of Chemistry, Chung Ang University, Seoul Korea.
- [3] M. Ringer, V. Putsche, and J. Scahill, November 2006, *Large-Scale Pyrolysis Oil Production: A Technology Assessment and Economic Analysis*, A national laboratory of the U.S. Department of Energy Office of Energy Efficiency & Renewable Energy.



## APPENDIX

### UV-Visible Test Results

#### 6.1 Water as base:

##### 6.1.1 100% Acetone (A)

Table 8: Peak pick for 100% Acetone (Water Base)

No.	P/V	Wavelength nm.	Abs.
1	☉	728.50	-0.032
2	☉	690.50	-0.027
3	☉	531.00	-0.021
4	☉	490.00	-0.020
5	☉	459.00	-0.018
6	☉	431.00	-0.017
7	☉	403.50	-0.015
8	☉	382.50	-0.014
9	☉	359.50	-0.013
10	☉	341.50	-0.011
11	☉	325.50	-0.007
12	☉	287.00	0.023
13	☉	788.50	-0.036
14	☉	553.50	-0.024
15	☉	477.00	-0.022
16	☉	445.00	-0.020
17	☉	394.00	-0.018
18	☉	372.00	-0.017
19	☉	355.50	-0.016
20	☉	336.00	-0.013
21	☉	253.00	0.002

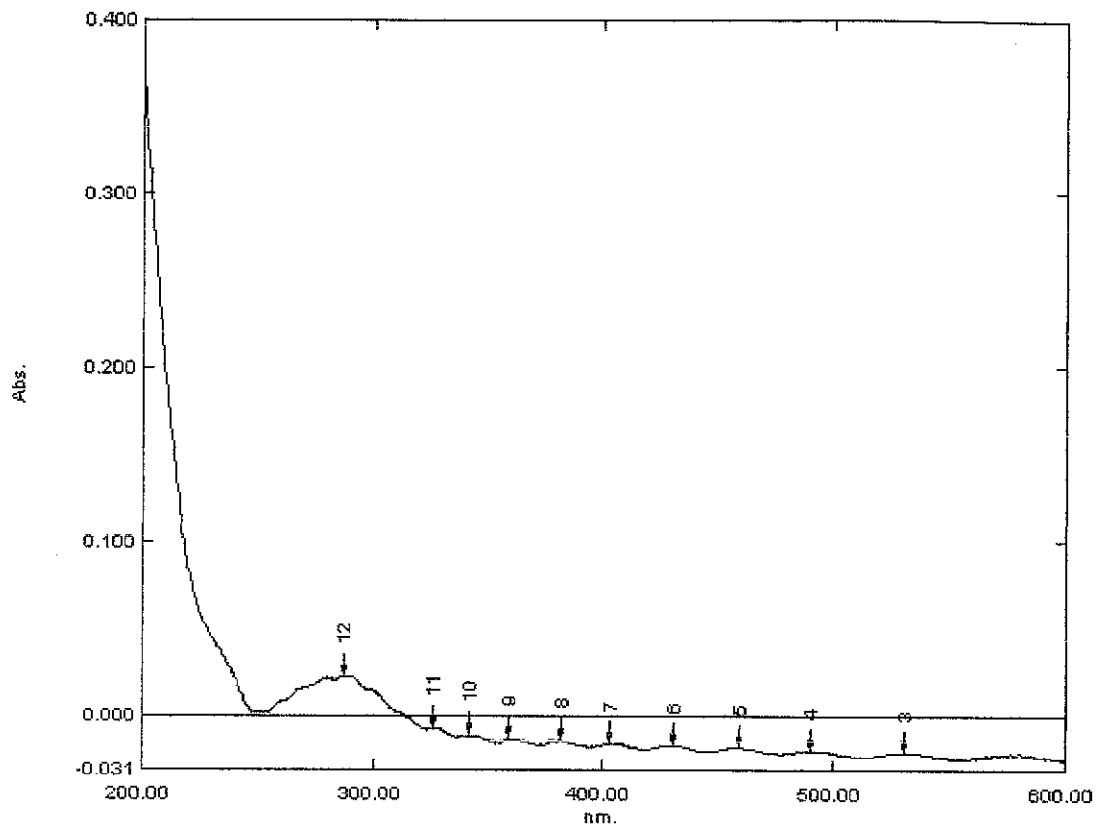
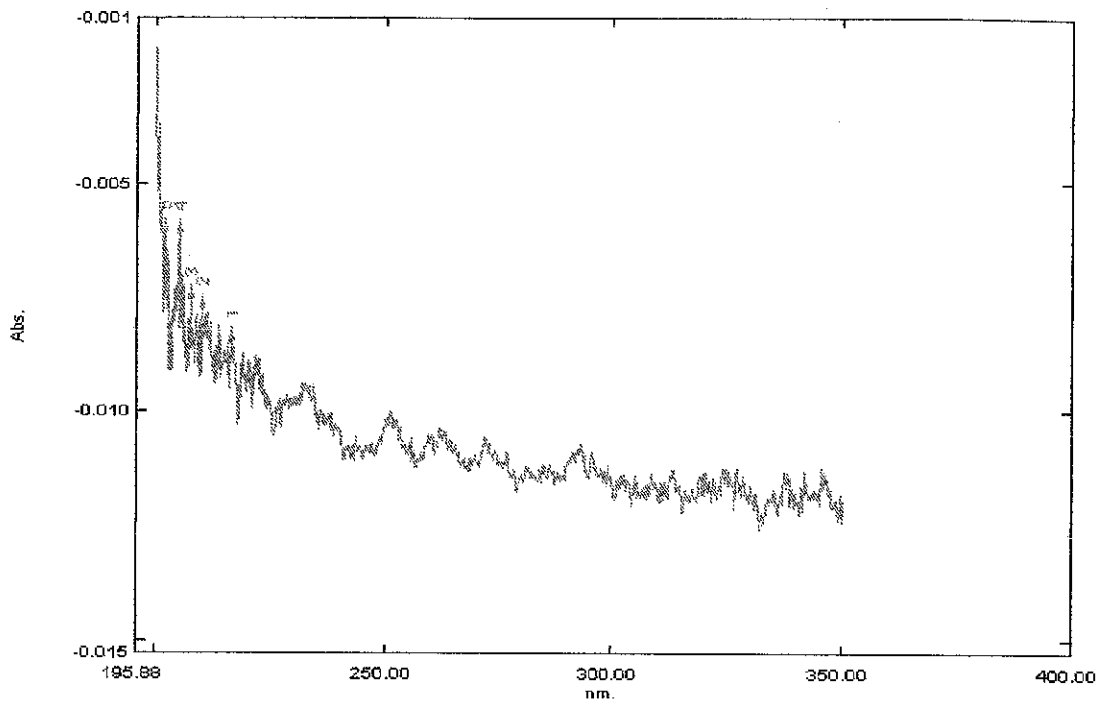

**Figure 14: Resulting curve for 100% Acetone (Water Base)**

**6.1.2 10% Acetone(G)**

**Table 9: Peak pick for 10% Acetone (Water Base)**

Peak Pick			
No.	P/V	Wavelength nm.	Abs.
1	⊗	216.30	-0.009
2	⊗	210.10	-0.008
3	⊗	207.50	-0.008
4	⊗	205.00	-0.006
5	⊗	202.00	-0.006
6	⊗	217.80	-0.010
7	⊗	209.70	-0.009
8	⊗	206.60	-0.009
9	⊗	203.40	-0.009
10	⊗	201.60	-0.008

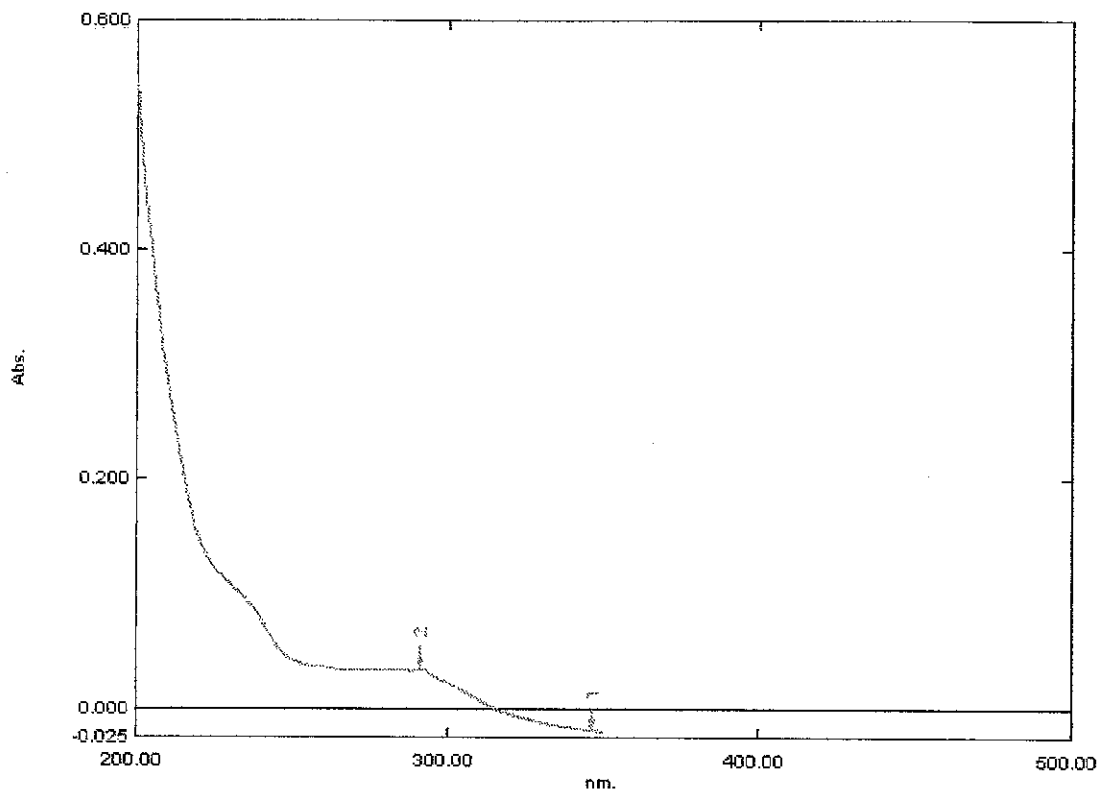

**Figure 15: Resulting curve for 10% Acetone (Water Base)**

### 6.1.3 20% Acetone(F)

**Table 10: Peak pick for 20% Acetone (Water Base)**

Peak Pick			
No.	P/V	Wavelength nm.	Abs.
1	⊗	346.40	-0.018
2	⊗	290.70	0.034
3	⊗	323.30	-0.008

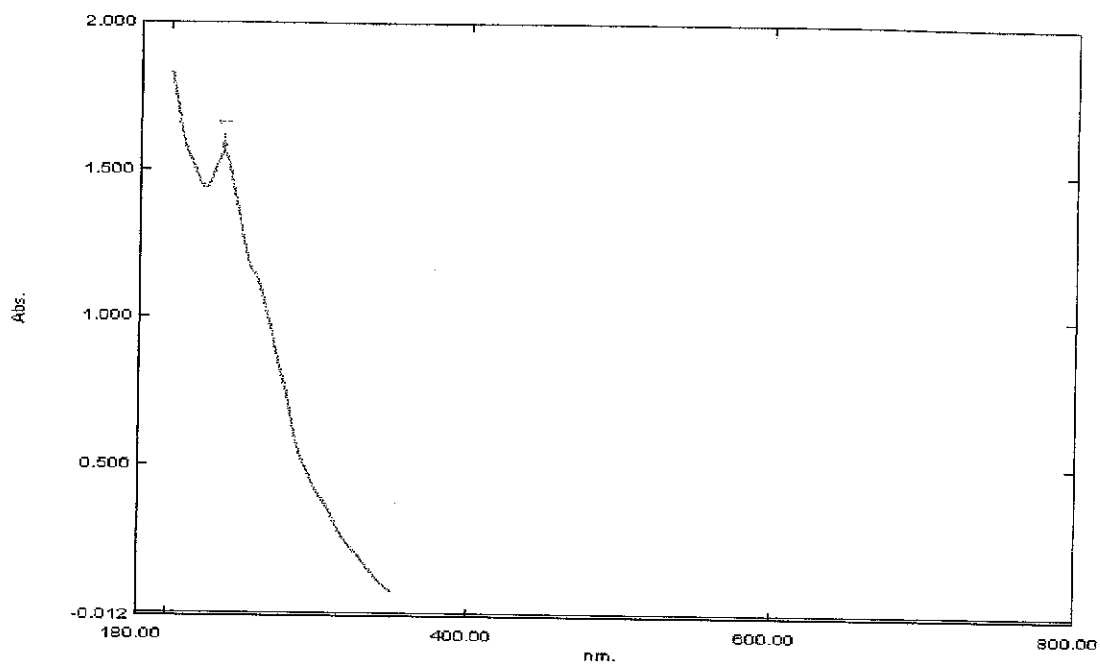

**Figure 16: Resulting curve for 20% Acetone (Water Base)**

### 6.1.3 40% Acetone(E)

**Table 11: Peak pick for 40% Acetone (Water Base)**

No.	P/V	Wavelength nm.	Abs.
1	⊕	234.50	1.556
2	⊕	222.50	1.438

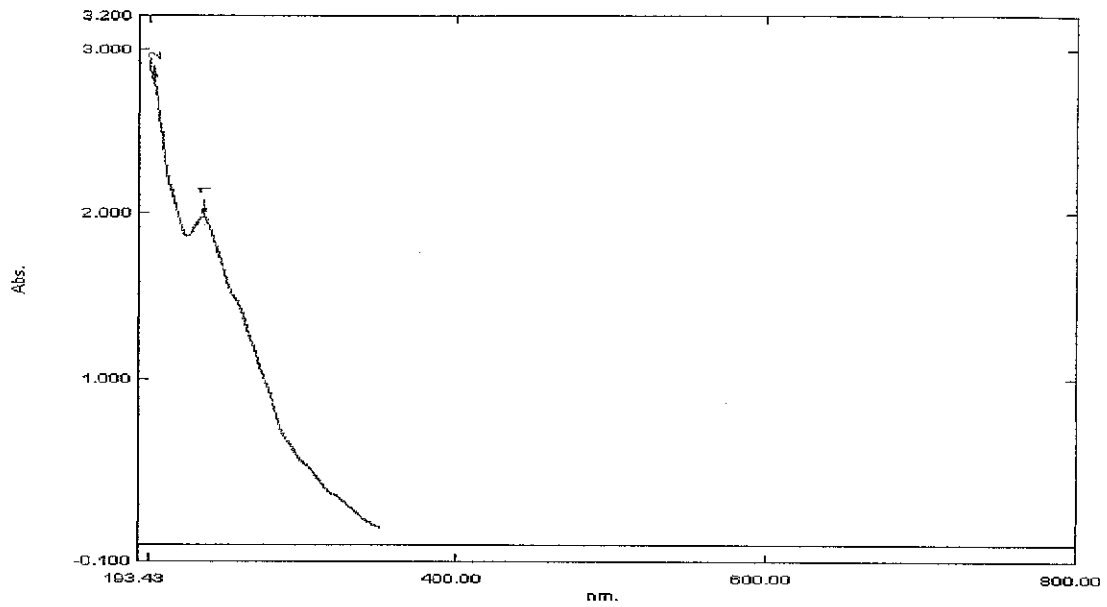

**Figure 17: Resulting curve for 40% Acetone (Water Base)**

**6.1.4 60% Acetone(D)**

**Table 12: Peak pick for 60% Acetone (Water Base)**

Peak Pick			
No.	P/V	Wavelength nm.	Abs.
1	⊕	234.90	1.981
2	⊕	203.30	2.790
3	⊖	225.40	1.866
4	⊖	202.90	2.782

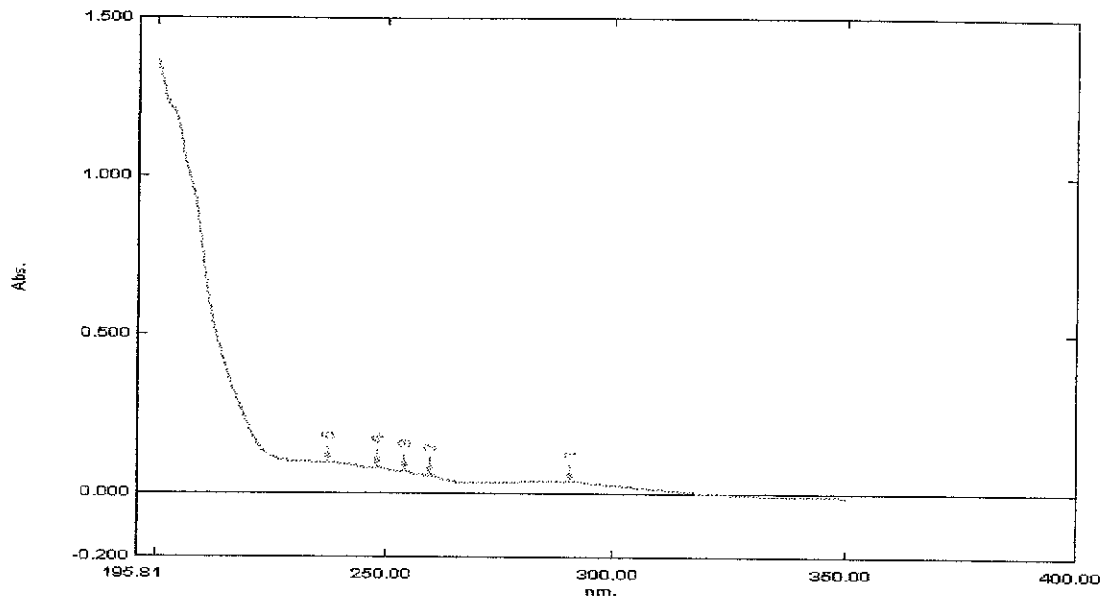

**Figure 18: Resulting curve for 60% Acetone (Water Base)**

**6.1.5 80% Acetone (C)**

**Table 13: Peak pick for 80% Acetone (Water Base)**

Peak Pick			
No.	P/V	Wavelength nm.	Abs.
1	⊕	290.80	0.040
2	⊕	259.80	0.059
3	⊕	254.00	0.072
4	⊕	248.10	0.084
5	⊕	237.20	0.099
6	⊖	267.20	0.035
7	⊖	258.70	0.058
8	⊖	252.70	0.070
9	⊖	246.50	0.080
10	⊖	235.60	0.098

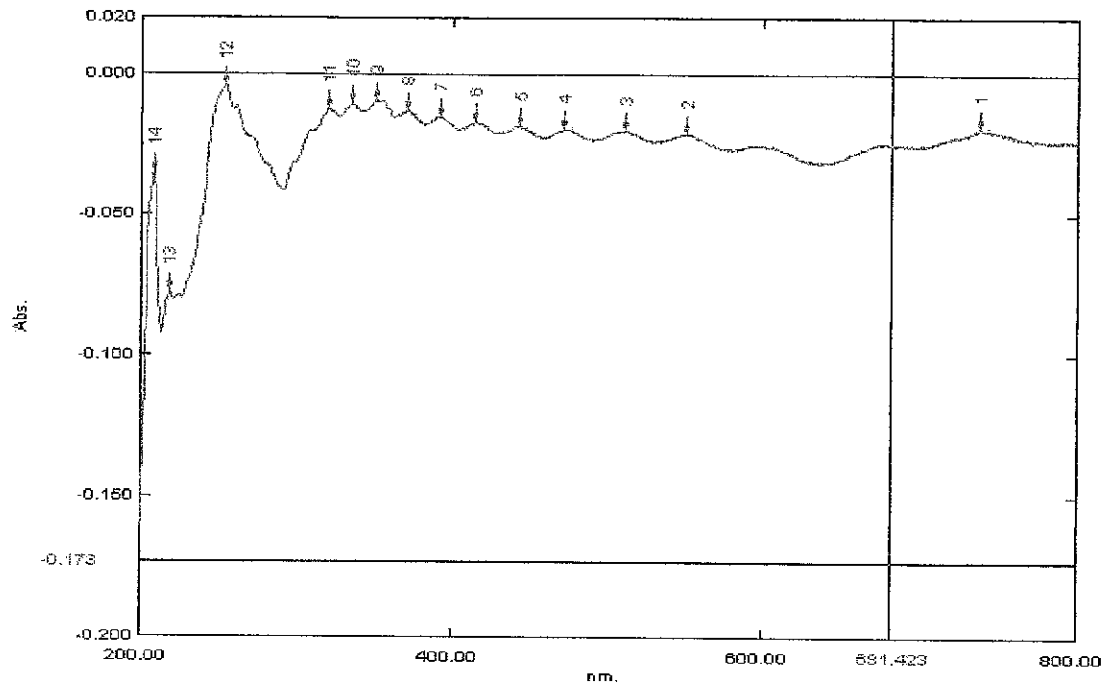

**Figure 19: Resulting curve for 80% Acetone (Water Base)**

**6.2 Acetone as base:**

**6.2.1 20% Water (C)**

**Table 14: Peak pick for 20% Water (Acetone Base)**



**Figure 20: Resulting curve for 20% Water (Acetone Base)**

**6.2.2 40% Water (D)**

**Table 15: Peak pick for 40% Water (Acetone Base)**



Peak Pick			
No.	P/V	Wavelength nm.	Abs.
1	⊗	600.50	-0.024
2	⊗	550.00	-0.020
3	⊗	512.50	-0.019
4	⊗	474.00	-0.019
5	⊗	442.00	-0.018
6	⊗	416.50	-0.017
7	⊗	392.50	-0.015
8	⊗	370.00	-0.012
9	⊗	354.00	-0.007
10	⊗	350.00	-0.007
11	⊗	335.00	-0.006
12	⊗	320.00	-0.006
13	⊗	308.00	-0.010
14	⊗	253.50	0.035
15	⊗	459.00	-0.022
16	⊗	430.00	-0.020
17	⊗	403.50	-0.019
18	⊗	383.50	-0.017
19	⊗	362.50	-0.014
20	⊗	342.00	-0.010
21	⊗	328.00	-0.009
22	⊗	311.50	-0.012
23	⊗	291.00	-0.028

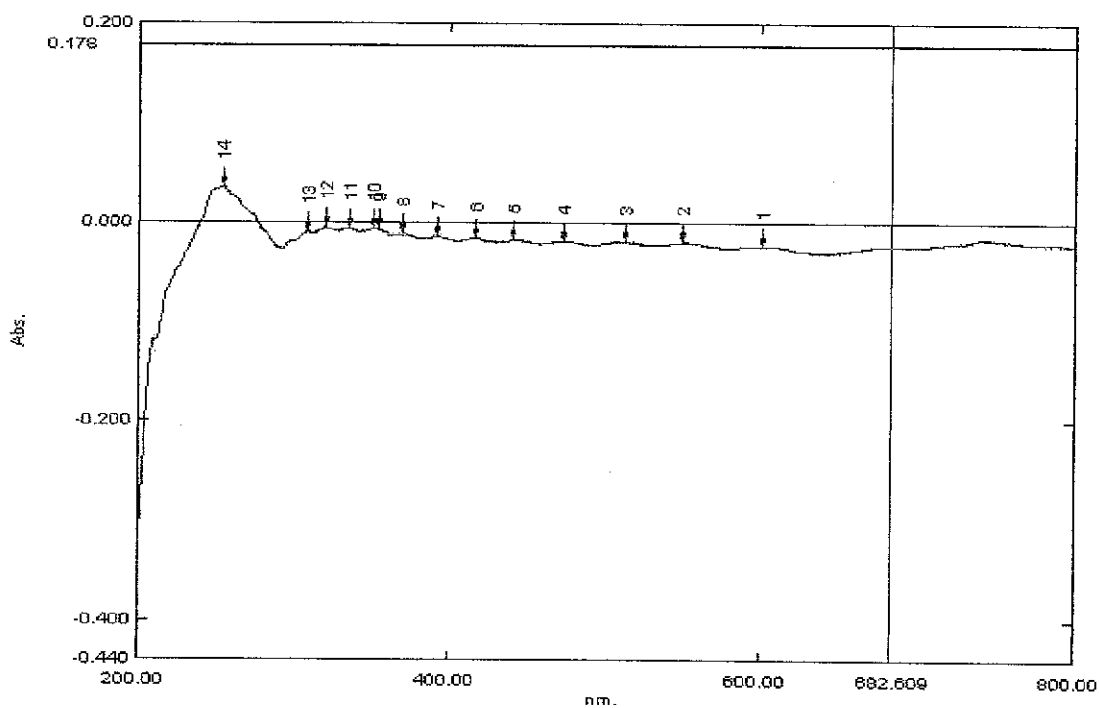

Figure 21: Resulting curve for 40% Water (Acetone Base)

#### 6.2.4 60% Water(E)

Table 16: Peak pick for 60% Water (Acetone Base)

Peak Pick			
No.	P/W	Wavelength nm.	Abs.
1	⊗	600.00	-0.025
2	⊗	444.50	-0.019
3	⊗	416.00	-0.018
4	⊗	392.00	-0.017
5	⊗	370.00	-0.016
6	⊗	355.00	-0.013
7	⊗	334.50	-0.016
8	⊗	320.50	-0.019
9	⊗	262.50	-0.033
10	⊗	253.50	-0.034
11	⊗	724.50	-0.019
12	⊗	491.50	-0.024
13	⊗	459.00	-0.023
14	⊗	428.00	-0.022
15	⊗	403.00	-0.021
16	⊗	382.50	-0.020
17	⊗	361.50	-0.018
18	⊗	341.00	-0.018
19	⊗	326.00	-0.021
20	⊗	291.00	-0.055
21	⊗	258.00	-0.038

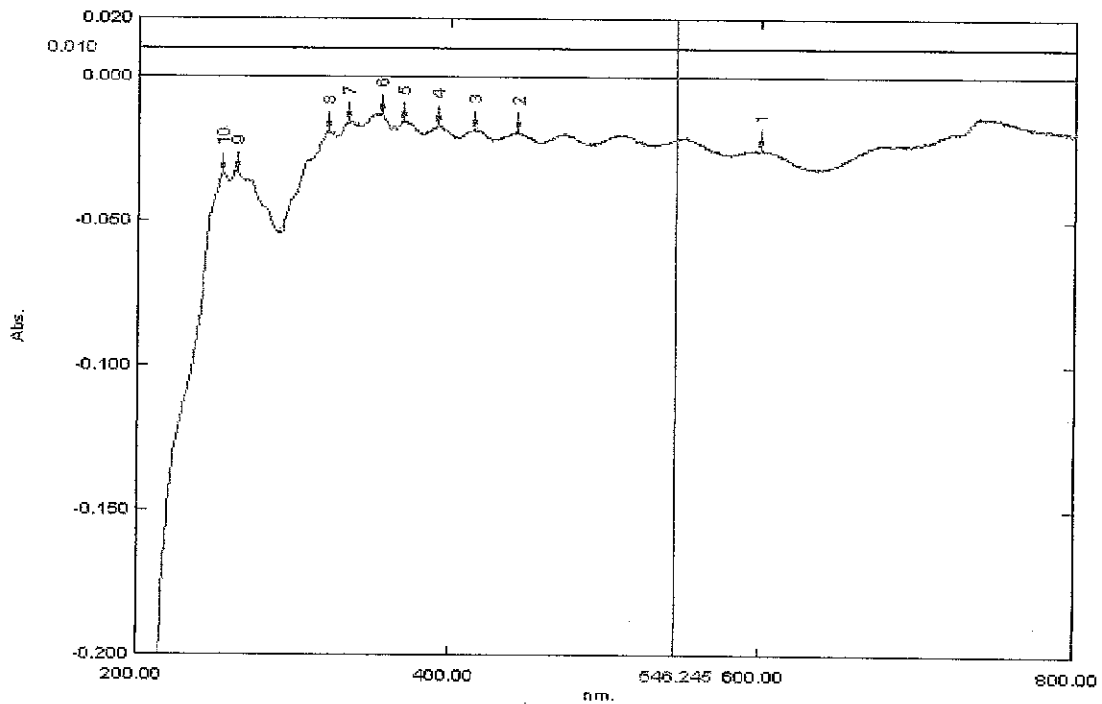

Figure 22: Resulting curve for 60% Water (Acetone Base)

### 6.2.5 80% Water(F)

Table 17: Peak pick for 80% Water (Acetone Base)

Peak Pick			
No.	P/V	Wavelength nm.	Abs.
1		474.50	-0.022
2		444.00	-0.021
3		416.50	-0.020
4		392.50	-0.019
5		370.50	-0.018
6		353.50	-0.015
7		334.50	-0.017
8		320.50	-0.018
9		308.00	-0.025
10		281.50	-0.040
11		272.00	-0.034
12		262.50	-0.032
13		253.50	-0.033
14		728.00	-0.020
15		458.50	-0.025
16		428.00	-0.024
17		404.00	-0.023
18		382.00	-0.022
19		362.00	-0.020
20		341.00	-0.019
21		327.00	-0.022
22		310.50	-0.026
23		289.50	-0.046
24		279.50	-0.041
25		267.00	-0.035

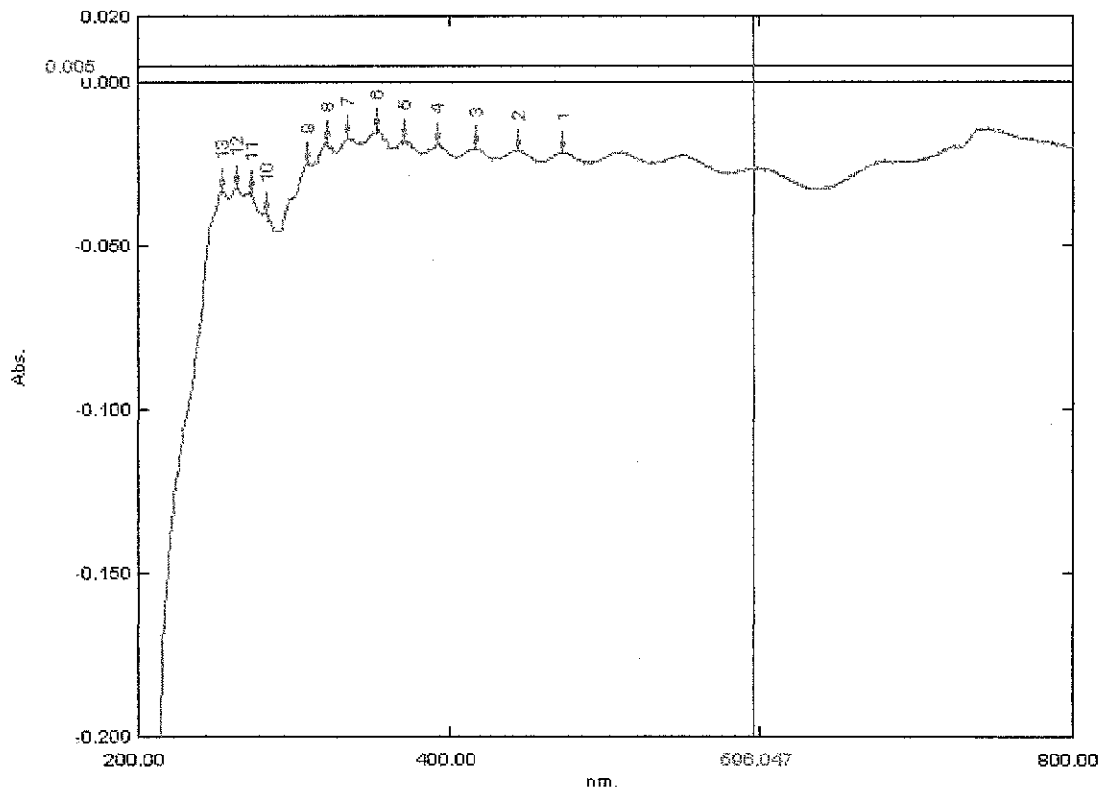
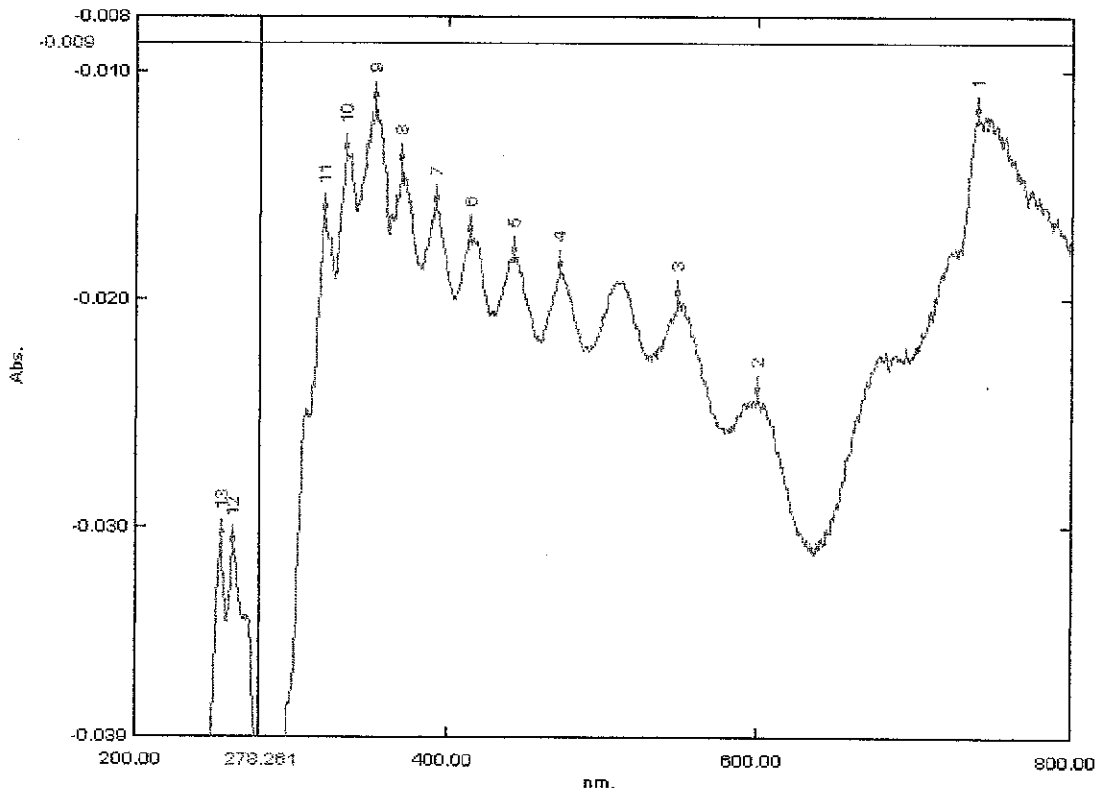

Figure 23: Resulting curve for 80% Water (Acetone Base)

### 6.2.6 90% Water(G)

**Table 18: Peak pick for 90% Water (Acetone Base)**

Peak Pick			
No.	P/V	Wavelength nm.	Abs.
1	⊗	740.00	-0.012
2	⊗	600.00	-0.024
3	⊗	549.00	-0.020
4	⊗	473.00	-0.019
5	⊗	442.50	-0.018
6	⊗	414.50	-0.017
7	⊗	392.00	-0.016
8	⊗	370.00	-0.014
9	⊗	353.50	-0.011
10	⊗	334.50	-0.014
11	⊗	320.00	-0.016
12	⊗	262.00	-0.031
13	⊗	254.00	-0.031
14	⊗	696.50	-0.023
15	⊗	636.50	-0.031
16	⊗	532.00	-0.023
17	⊗	492.00	-0.022
18	⊗	427.50	-0.021
19	⊗	404.00	-0.020
20	⊗	383.00	-0.019
21	⊗	362.00	-0.017
22	⊗	341.00	-0.016
23	⊗	327.00	-0.019
24	⊗	291.00	-0.049
25	⊗	258.00	-0.034



**Figure 24: Resulting curve for 90% Water (Acetone Base)**

### 6.3 No base:

#### 6.3.1 20% Water(C)

Table 19: Peak pick for 20% Water (No Base)

Peak Pick			
No.	P/V	Wavelength nm:	Abs.
1		291.80	0.148
2		281.80	0.146
3		272.30	0.139
4		260.60	0.142
5		254.30	0.140
6		275.40	0.138
7		265.90	0.133
8		256.10	0.137
9		249.80	0.135

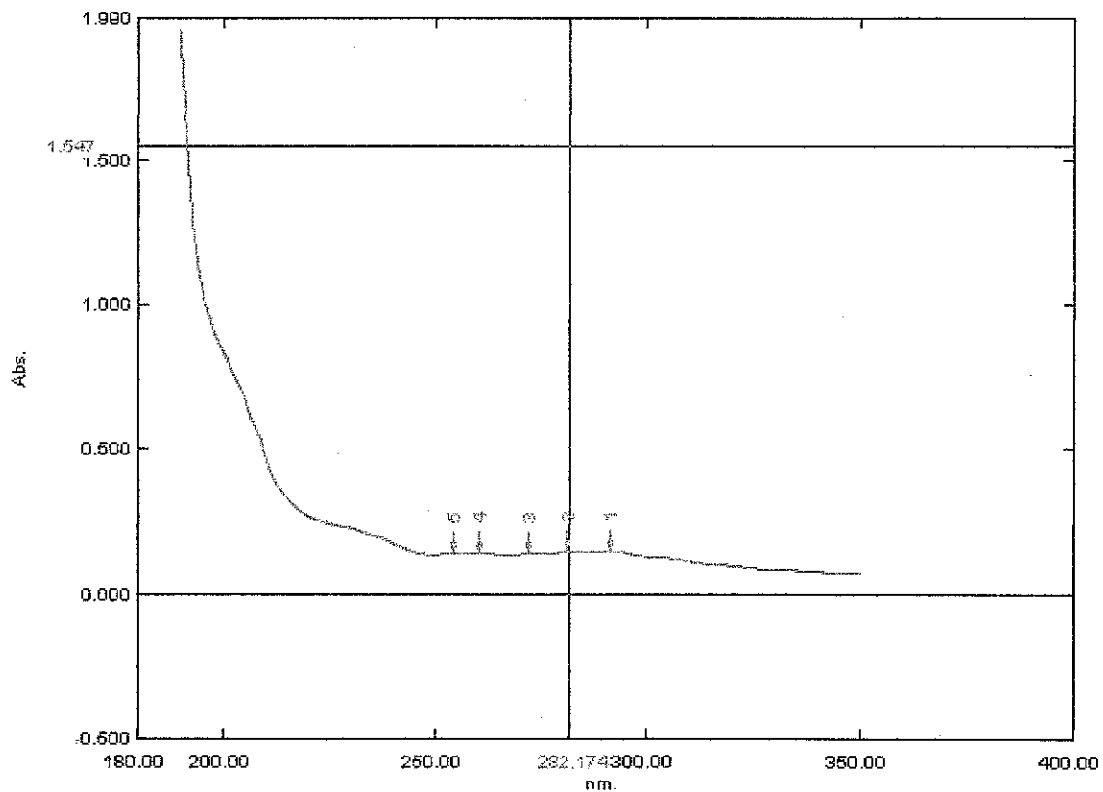
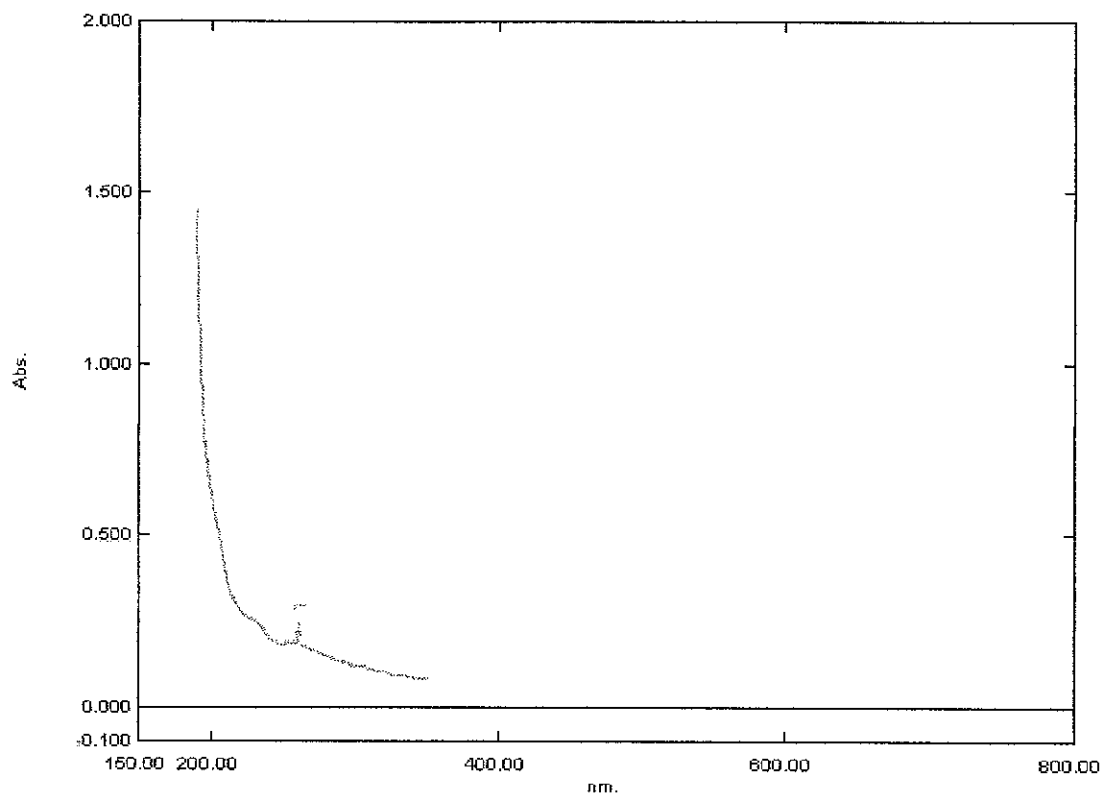

Figure 25: Resulting curve for 20% Water (Acetone Base)

#### 6.3.2 40% Water(D)

**Table 20: Peak pick for 40% Water (No Base)**

Peak Pick			
No.	P/W	Wavelength nm.	Abs.
1	⊕	260.30	0.184
2	⊖	347.30	0.080

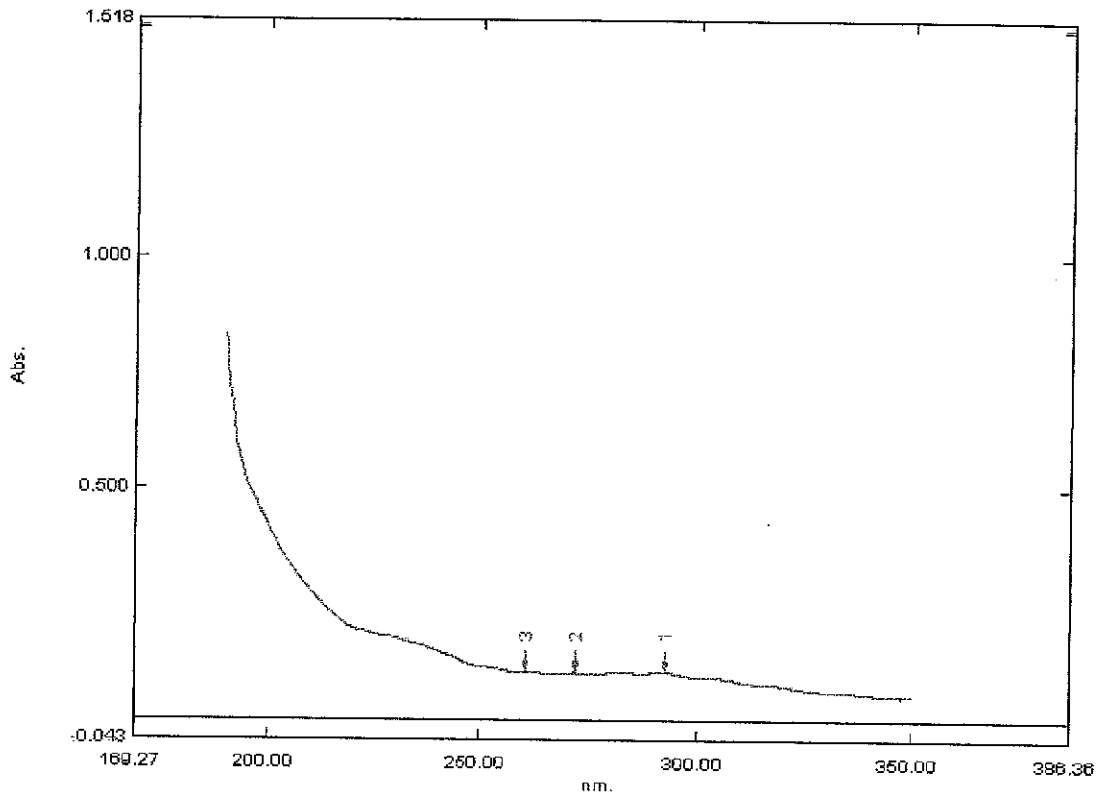

**Figure 26: Resulting curve for 40% Water (Acetone Base)**

### 6.3.3 60% Water(E)

**Table 21: Peak pick for 60% Water (No Base)**

Peak Pick			
No.	P/V	Wavelength nm.	Abs.
1	⊕	292.70	0.104
2	⊕	272.10	0.102
3	⊕	260.80	0.105
4	⊕	276.60	0.099
5	⊕	257.80	0.104

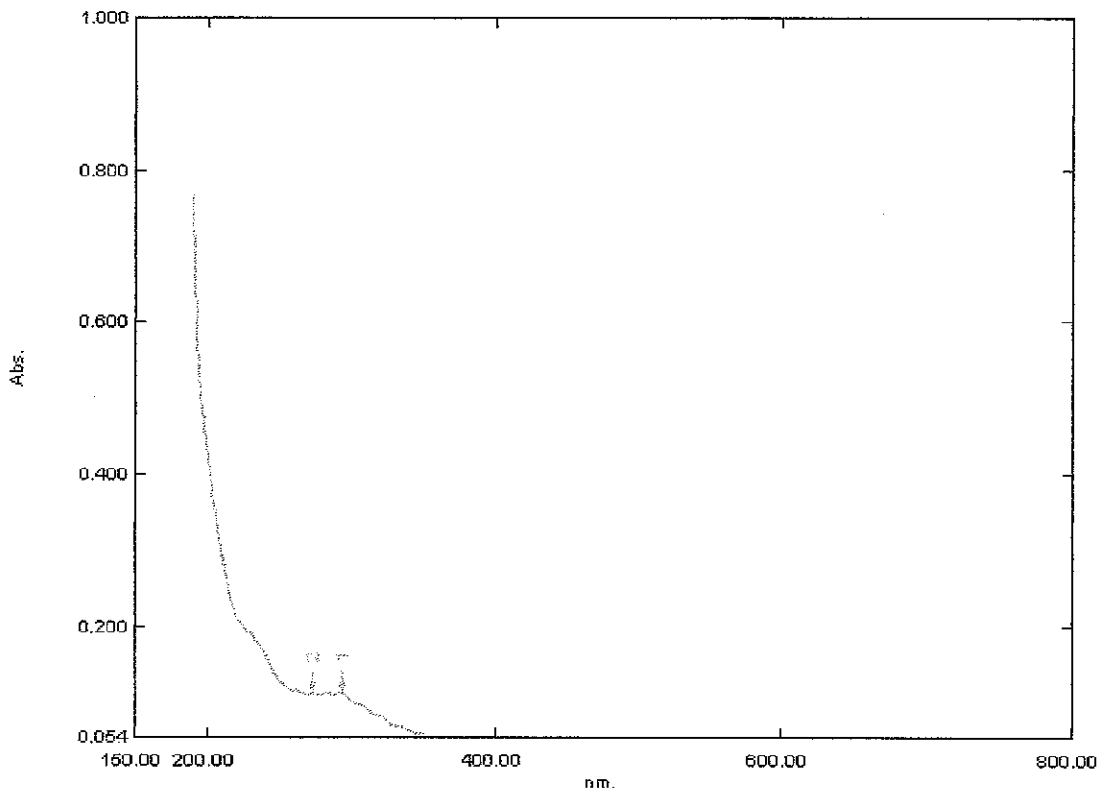

**Figure 27: Resulting curve for 60% Water (Acetone Base)**

#### 6.3.4 80% Water(F)

**Table 22: Peak pick for 80% Water (No Base)**

Peak Pick			
No.	P/V	Wavelength nm.	Abs.
1	⊕	292.20	0.112
2	⊕	271.90	0.113
3	⊕	258.50	0.115



**Figure 28: Resulting curve for 80% Water (Acetone Base)**