

**DESIGN HARNESSING HOT SPRING'S ENERGY SYSTEM FOR COCOA
BEANS DRYING**

By

Muhamad Izdan Zul Izzi b. Mahamad Rezali

Dissertation Report submitted in fulfillment of
the requirements for the
Bachelor of Engineering (Hons)
(Mechanical Engineering)

JANUARY 2009

Universiti Teknologi PETRONAS
Bandar Seri Iskandar
31750 Tronoh
Perak Darul Ridzuan

t
TJ
230.7
-M952
2009

D Geothermal engineering

CERTIFICATION OF APPROVAL

DESIGN HARNESSING HOT SPRING'S ENERGY SYSTEM FOR COCOA BEANS DRYING

by

Muhamad Izdan Zul Izzi b. Mahamad Rezali

A project dissertation submitted to the
Mechanical Engineering Programme
Universiti Teknologi PETRONAS
in partial fulfilment of the requirement for the
BACHELOR OF ENGINEERING (Hons)
(MECHANICAL ENGINEERING)

Approved:

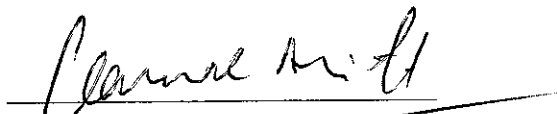
(Tn. Hj. Kamal Ariff b. Zainal Abidin)

UNIVERSITI TEKNOLOGI PETRONAS
TRONOH, PERAK
January 2009

CERTIFICATION OF ORIGINALITY

This is to certify that I am responsible for the work submitted in this project, that the original work is my own except as specified in the references and acknowledgements, and that the original work contained herein have not been undertaken or done by unspecified sources or persons.

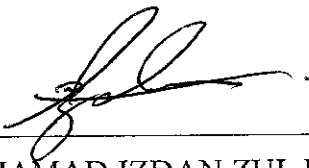

MUHAMAD IZDAN ZUL IZZI B. MAHAMAD REZALI

ABSTRACT

Geothermal energy is a one type source of alternative energy. Countries like United Stated, Australia, New Zealand, China, Canada and Turkey have used this energy for some applications such as for electricity generation, space and district heating, air conditioning, greenhouse heating and others. The presence of volcanoes, hot springs and other thermal phenomena lead people to explore and study energy produced inside earth. In Malaysia, there are also some places have the hot springs in Tambun, Sungkai, Pengkalan Hulu, Manong and others and currently use for recreation and tourism. For this project, the author wants to study and understanding this one type of alternative energy and design suitable system to harness hot spring's energy and used for cocoa beans drying (industrial application). The problems that are being created from energy price hiking and our equator climate lead the author to find the solutions. The target is to design a suitable system which can harness hot spring's energy and applied it on cocoa beans drying process. Since the energy is free and continuously produced inside the earth, the author wants to find the way how to commercial the energy. The important elements that need to be determine before starts the design is the behaviour of cocoa beans while drying and the unknowns related to the design that must being determine using the experiment and engineering calculations. The design must be in details for future works. This project can solve the problems of inconsistently weather condition and high price for fuel and gas that being used for artificial drying. This project also can make improvement with maximizing the quantity of the dried cocoa beans without affecting the quality.

ACKNOWLEDGEMENTS

Bless to God for giving the author strength and chance to complete the Final Year Project (FYP) and this dissertation report. The author would like to extend his greatest gratitude to many individuals who contributed to this project. The first thank goes to his UTP Supervisor, Tn. HJ. Kamal Ariff b. Zainal Abidin for the supervision, information and advises plus giving freedom to learn throughout the project. This project could not complete without extensive assistance provide by Tn. Hj. Kamal Ariff b. Zainal Abidin The author also indebted with UTP Mechanical Engineering Lecturer, Prof Dr. Vijay R. Raghavan who spending his time with author giving technical expertise advises, explanations, knowledge and experiences as well. Thank you for your help. To all lecturers from Mechanical Engineering Department of University Technology of PETRONAS, thanks for giving the author cooperation and support in undergoing this project.

The author also wants to thank Mr. Dzazali Ayub from Mineral & Geosciences Department Malaysia, Dr. Lee Choon Hoi and Mrs Hajjah Faridah from Malaysia Cocoa Board who are really help him by giving information and advises during his visit. Last but not least, thank you to all friends and family who help author in making this project possible to finish, including the support, advice, encouragement and praying.

Thank you.

The Author,

Muhamad Izdan Zul Izzi b. Mahamad Rezali
Mechanical Engineering Student, UTP

TABLE OF CONTENTS

Certification of Approval	ii
Certification of Originality	iii
Abstract	iv
Acknowledgement	v
Table of Contents	vi
List of Illustrations	viii
CHAPTER INTRODUCTION	1
1 1.1 Background Studies	1
1.2 Problem Statement	2
1.3 Objectives	3
1.4 Scope of Study	3
1.5 Significance of the Project	4
CHAPTER LITERATURE REVIEW	5
2 2.1 Theory Energy from Earth	5
2.2 Direct Use of Geothermal Energy	8
2.3 Tapping the Resource	9
2.4 Cocoa Beans Drying Process	10
2.5 Moisture of Cocoa Beans	13
2.6 Sungai Klah Hot Springs	15
CHAPTER METHODOLOGY	16
3 3.1 Start the Project	18
3.2 Literature Review	18
3.3 Visit Mineral & Geosciences Department	18
3.4 Design Standard and Specifications	18
3.5 Pre-Designing the System	19
3.6 Visit Malaysia Cocoa Board	19
3.7 Experiment Drying Fermented Cocoa Beans	19

	3.8 Calculations Related to the Design	19
	3.8.1 Length of Steel Pipe	19
	3.8.2 Heat Transfer in the System	19
	3.8.3 Time of Drying	20
	3.9 Designing the System	20
CHAPTER	RESULTS AND DISCUSSIONS	21
4	4.1 Location selected	21
	4.2 Data Gathering	21
	4.3 Visit Mineral & Geosciences Department	21
	4.4 Design Standard and Specifications	21
	4.4.1 Alternative Solution	23
	4.5 Pre-Designing the System	23
	4.5.1 Drying House Process Flow	24
	4.6 Visit Malaysia Cocoa Board	26
	4.7 Experiment Cocoa Beans Drying	26
	4.8 Engineering Calculations Related to the Design	29
	4.8.1 Length of Steel Pipe	30
	4.8.2 Heat Transfer in the System	31
	4.8.3 Drying Time for the System	32
	4.9 Design of the System	33
	4.10 Discussions Regarding the Design	37
	4.11 Corrosion Prevention	37
CHAPTER	CONCLUSIONS AND RECOMMENDATIONS	38
5	5.1 Conclusions	38
	5.2 Recommendations	39
	REFERENCES	40
	APPENDIX A: SUN DRYING METHOD	41
	APPENDIX B: LOCATION OF SUNGAI KLAH, PERAK	42
	APPENDIX C: CONDUCTIVE ZONE AT SUNGAI KLAH	43
	APPENDIX D: PROCEDURE COCOA BEANS DRYING EXPERIMENT	44
	APPENDIX E: EXPERIMENT DRYING COCOA BEANS	46

LIST OF ILLUSTRATIONS

Figures

Figure 2.1: How Hot Water Produced Inside Earth	6
Figure 2.2: Natural Conditions of Water Cycle	6
Figure 2.3: Greenhouse	9
Figure 2.4: Cocoa Beans Dying Process Flow	11
Figure 2.5: Moisture Indicator	13
Figure 2.6: Electromagnetic SIROTEM	15
Figure 3.1: Flow Chart of the Project	17
Figure 4.1: Pre-Designing Harnessing System for Cocoa Beans Drying	25
Figure 4.2: Graph of Reduction Water versus Time	27
Figure 4.3: Graph Moisture of Content versus Time	28
Figure 4.4: Wall Thickness of Steel Pipe	29
Figure 4.5: Resistance in the System	29
Figure 4.6: Orthographic View of Rack	32
Figure 4.7: Orthographic View of Meshed Tray	34
Figure 4.8: Positions Trays on Rack	34
Figure 4.9: Orthographic View of Drying House	35
Figure 4.10: Design of the System	36

Tables

Table 4.1: Comparison with All Types of Cocoa Beans Drying System	23
Table 4.2: Result for Cocoa Beans Drying Experiment at 50 °C	26

CHAPTER 1

INTRODUCTION

1.0 INTRODUCTION

1.1 Background of Study

Basically geothermal energy has attracted many countries since after the Second World War. This is because this energy considers being economically competitive compare with other forms of energy. This energy no needs to be imported and available locally. This energy continuously produces in the earth and absolutely free. There are over 20 countries have used this geothermal energy for their alternative source of energy and being used for some applications such as electricity generation, heating system and others. The presence of the volcanoes, hot springs and other thermal phenomena led people to explore and study what energy from earth produce. In Malaysia, especially in Perak, there are also some places have the hot springs in Tambun, Sungkai, Pengkalan Hulu, Manong and others. The temperature of those hot springs are high enough even eggs can be boil into it. Those places currently use for recreation and tourism.

The target in this project is to design suitable system to harness hot spring's energy which can use the energy in cocoa beans drying. The author choose cocoa beans for this project since cocoa is being list top plantations that being produce in Malaysia and needs to be dry before can be process to become chocolate. For information, Malaysia is the 3rd largest producer of cocoa in the world and Perak is the 3rd largest producer in Malaysia. There are several places in Perak where people involve in cocoa plantations such as in Lahat, Parit Buntar, Selekoh, Sungkai and Tanjung Malim. Since in Perak also has several hot springs, the author want to design a system that can harness that energy applied the energy for cocoa beans drying. Basically the energy that being harness from hot spring will be going to use to replace fuel that currently used by the

people in that area for artificial drying (alternative ways of sun drying). People used fuel during the raining day. Since this energy is free and continuously produced inside the earth, the author wants to try to design suitable system that can harness energy from earth and use it for cocoa beans drying.

1.2 Problem Statement

As you can see current energy such as oil and gas have the higher price in market. Example crude oil price for one barrel is \$130 and consider high since all countries have high demand on oil. For alternative, we want to find other types energy which is more reliable to reduce life cost for citizens. In Malaysia, we have several places which have hot springs that being formed from ground water that come out to the earth like in Perak and Kedah. Basically these places are being use for recreation and tourism. The heat inside the earth makes the water hot. If possible, the author wants to study on how to harness hot spring's energy and then applied it on cocoa beans drying process for industrial application. The author want to design suitable system that can harness another alternative energy for our country and overcome the problem that currently happened in all regions in the world.

For information, Malaysia is the 3rd largest producer of cocoa n the world. Sabah is the largest producer of cocoa in our country, followed by Pahang and Perak. Basically our climate is equator climate which is not consistent, either wet or dry. This weather climate creates problem for those who are involves in plantation drying especially cocoa beans. To overcome this problem, the author wants to propose the design of the system that can harness energy inside the earth and make sure the cocoa beans can be dry at any time (24 hours working) with the minimum cost of energy. This system basically will be operating with the hot water that we take from reservoir and heat will be transfer in the system and dry the products which are cocoa beans. Hopefully this system can overcome the problems that being facing in cocoa beans farmer and producer.

1.3 Objectives

Objective of this project is to design harnessing hot springs energy system for cocoa beans drying. It includes the calculations to determine the unknowns and also the details design regarding this project in order to overcome the problems that have been facing by people involved in cocoa plantations.

1.4 Scope of Study

In order to accomplish this project, the scopes of study are:

- i. To understand the current applications using hot spring's energy.

In order to achieve the understanding of applications using energy from earth, the author needs to do research on several applications such as vegetable dehydration, aquaculture and greenhouse that have been doing by other countries. The author also needs to determine how this energy produce inside the earth and benefits that being will get when using this kind of energy. This project also covered potential places in Malaysia which has hot springs and cocoa plantation nearby. The research also needs to be done in order to determine whether this energy can give negative and big impact to environmental or not.

- ii. To determine the behaviour on cocoa beans while drying.

The behaviours of cocoa beans while drying can be determine using the experiment. The drying curve can be generated from this experiment and the explanations regarding the curve can be made. The drying curve is the basic fundamental in heat transfer applications and need to understand before starts the design. The pattern of behaviour while drying the plantation products also can be proved with the drying curve.

- iii. To design harnessing hot spring's energy system

Pre-design of the system can give the rough idea how the system works. In order to design the system that can being used for cocoa beans drying, some engineering calculations need to be done by the author in order to determine the unknowns regarding the design. The design must have the dimensions, the function of equipments used and also how the process flows in the system.

1.5 Significance of Project

The significance of this project is that in the future, people who involved in cocoa plantations especially in cocoa drying can use the system and reduce the cost of the energy that they currently used if the system being able to implement. This project helps people to apply new source of alternative energy and new system which can help them to reduce the price, process cost, maintenances and manpower that they are going to pay for fuel and others things that they used for the combustion in artificial drying when the raining season come. The target if the system can be implement is using hot water from reservoir, maximize the energy can be supply from hot water and used sufficient temperature during cocoa beans drying so it can produced more dried cocoa beans without affecting the quality. The drying process will be more efficient using this system since it can overcome the problems energy price hiking in the market and also inconsistently weather condition.

CHAPTER 2

LITERATURE REVIEW

2.0 LITERATURE REVIEW

2.1 Theory Energy from Earth

The word **geothermal** comes from the Greek words *geo* (earth) and *therme* (heat). So, geothermal energy is heat from within the earth. We can use the steam and hot water produced inside the earth to heat buildings, generate electricity and others. Geothermal energy is a **renewable** energy source because the water is replenished by rainfall and the heat is continuously produced inside the earth. Geothermal energy is generated in the earth's core, about 4,000 miles below the surface. Temperatures hotter than the sun's surface are continuously produced inside the earth by the slow decay of radioactive particles, a process that happens in all rocks. The earth has a number of different layers as shown below [10]:

- The core itself has two layers: a **solid iron core** and an outer core made of very hot melted rock, called **magma**.
- The **mantle** which surrounds the core and is about 1,800 miles thick. It is made up of magma and rock.
- The **crust** is the outermost layer of the earth, the land that forms the continents and ocean floors. It can be three to five miles thick under the oceans and 15 to 35 miles thick on the continents.

Basically, the rainfall will be accepted at the forest (reception area) and then the water will be absorbed by the ground. The ground water will be heated by the rocks inside the ground. The rock inside the ground already been heated by the heat continuously produced inside the earth. The difference in pressure causes the hot water to go up to the surface through the crack inside the ground. This hot water that comes out

from the ground will form the hot springs. Since the water came from the ground after being heated by the hot rocks, there will be some minerals inside the water and in our case is sulphur. Figure 2.1 shows how hot water being produced inside earth. Figure 2.2 shows the natural conditions of water cycle and also ground water flow direction.

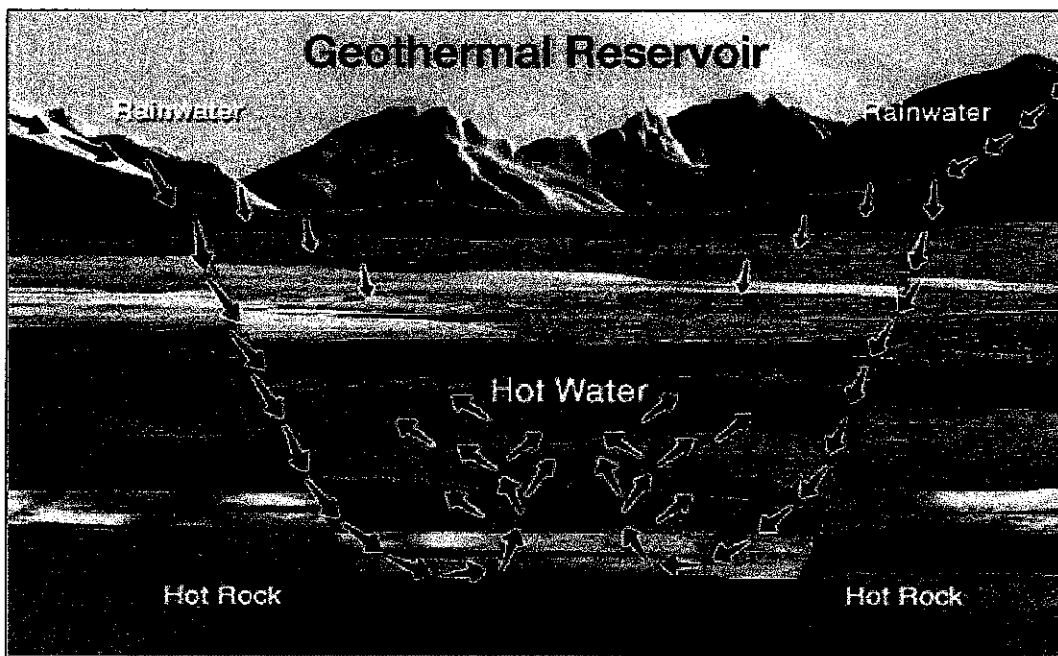

Figure 2.1: How hot water produced inside earth

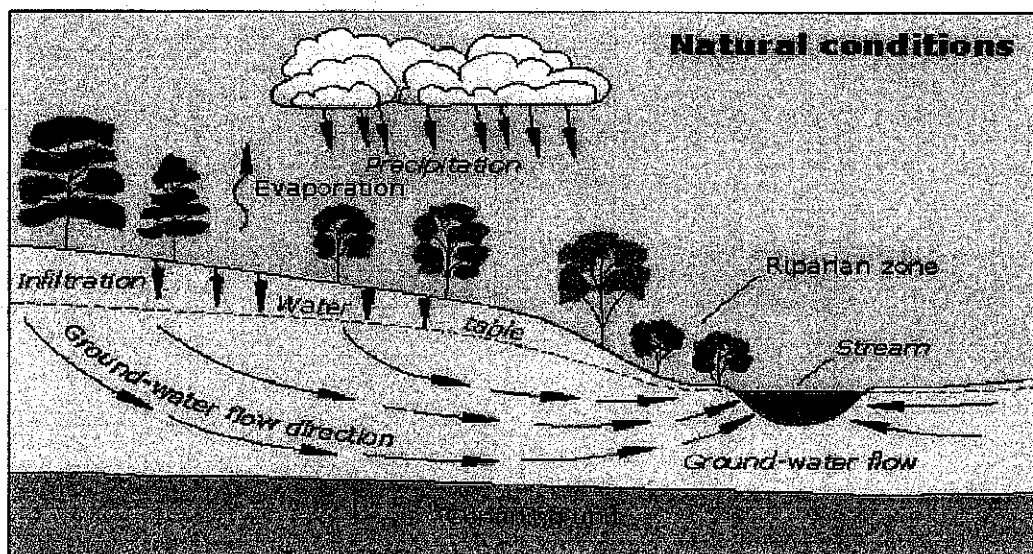

Figure 2.2: Natural conditions of water cycle

Some **applications** of geothermal energy use the earth's temperatures near the surface, while others require drilling miles into the earth. The three main uses of geothermal energy are:

- **Direct Use and District Heating Systems** which use hot water from springs or reservoirs near the surface.
- **Electricity generation** in a power plant requires water or steam at very high temperature (300 to 700 degrees Fahrenheit). Geothermal power plants are generally built where geothermal reservoirs are located within a mile or two of the surface.
- **Geothermal heat pumps** use stable ground or water temperatures near the earth's surface to control building temperatures above ground.

The **advantages** of this energy are:

- Geothermal power plants **work continuously**, day and night, making them base load power plants and.
- This energy offers a **degree of scalability**: a large geothermal plant can power entire cities while smaller power plants can supply more remote sites such as rural villages.
- It is also nearly **sustainable** because the heat extraction is small compared to the size of the heat reservoir, which may also receive some heat replenishment from greater depths.
- From an economic view, geothermal energy is extremely **price competitive** in some areas and reduces reliance on fossil fuels and their inherent price unpredictability.

The **disadvantages** of geothermal energy are:

- Geothermal fluid is corrosive, and worse, is at a relatively low temperature (compared to steam from boilers), which by the laws of thermodynamics limits the efficiency of heat engines in extracting useful energy as in the generation of electricity.
- Much of the heat energy is lost, unless there is also a local use for low-temperature heat, such as greenhouses or timber mills or district heating, etc.
- Dry steam and flash steam power plants also emit low levels of carbon dioxide, nitric oxide, and sulfur, although at roughly 5% of the levels emitted by fossil fuel power plants.
- Hot water from geothermal sources will contain trace amounts of dangerous elements such as mercury, arsenic, antimony, etc. which if disposed of into rivers can render their water unsafe to drink.

2.2 Direct Use of Geothermal Energy

In this project, I've chosen direct use system for implement in the system that will be developing. In this chapter, there are further explanations about direct use of geothermal energy.

Geothermal reservoirs of low-to moderate-temperature water – 68°F to 302°F (20°C to 150°C) – provide direct heat for residential, industrial, and commercial uses. The primary uses of low-temperature geothermal resources are in district and space heating, greenhouses, and aquaculture facilities. A 1996 survey found that these applications were using nearly 5.8 billion mega joules of geothermal energy each year – the energy equivalent of nearly 1.6 million barrels of oil. This resource is widespread around the world, and is used to heat homes and offices, commercial greenhouses, fish farms, food processing facilities, gold mining operations, and a variety of other applications. Spent fluids from geothermal electric plants can be subsequently used for direct use applications in so-called "cascaded" operation. Figure 2.3 shows that one of the example (greenhouse) using direct use of the geothermal energy.

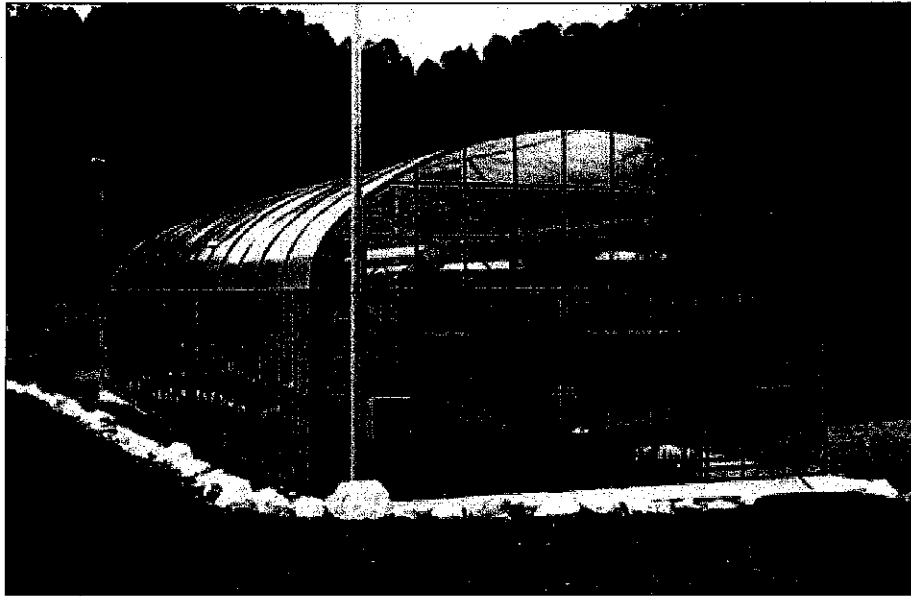

Figure 2.3: Greenhouse (Direct use applications)

Direct use of geothermal energy in homes and commercial operations is much less expensive than using traditional fuels. Savings can be as much as 80% over fossil fuels. Direct use is also very clean, producing only a small percentage (and in many cases none) of the air pollutants emitted by burning fossil fuels. This form of energy considered importance in many countries and that there are favourable condition to increase the direct use of geothermal energy in the region of all countries.

2.3 Tapping the Resource

Basically, there are several components when to use direct-use systems. There are three major components which are:

- A production facility – usually a well – to bring the hot water to the surface;
- A mechanical system – piping, heat exchanger, controls – to deliver the heat to the space or process
- A disposal system – injection well or storage pond – to receive the cooled geothermal fluid.

These systems can be bought off-the-shelf and can further be modified to suit specific sites. Geothermal projects require one time capital investment and the annual operational cost is minimize. While in the case of conventional projects, the capital cost includes the cost of the boiler and distribution lines and a large annual operational cost which is continuous and fluctuates depending on the cost of (ever increasing cost of oil, gas and low ash coal) fuel. Depending on the available resources, direct-use projects can operate for over 20 years with low down-time period. At present, nearly 70% of India's power production is based on coal due to the availability of huge coal reserves in the country. Excessive use of this source, without the use of strategies to mitigate its effects, will have deteriorating effect on the quality of human life.

2.4 Cocoa Bean Drying Process

After cocoa has been taken from the trees, farmers or persons involved in this industry will dry the cocoa bean before been selling to traders and manufacturer. Fresh cocoa bean has 50 – 60% moisture content and the target to reduce the moisture is about 7 – 8%. Basically, cocoa bean drying is the most important stages for farmers to produce good quality of the cocoa. The main reason cocoa bean being drying is because to slow down reaction of enzyme hydrolytic (enzyme inside cocoa beans) which can actively help spore to grow. The second reason is to reduce the moisture from the cocoa beans as a technique to avoid cocoa beans from becomes smelly and also to keep the aroma of the cocoa beans. From the studies of expertise, the drying temperature of cocoa bean must not exceed 60 °C to avoid case hardening to happen which is only outside been dry but not the inside. If the temperature exceeding 60 °C, it also can cause negative effect on the aroma development because of fast reducing sugar and also diminished acetic acid volatilization. Drying process is also ensuring a complete hydrolysis of sucrose into glucose and fructose. High concentration of glucose and fructose ensures a good aroma yield during roasting process. The cocoa beans drying process has been summarized in the figure 2.4.



Cocoa fruit taken from the trees after reach the matured level.

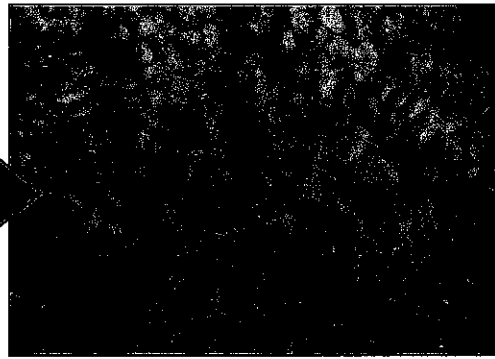

Cocoa beans will be removed from its shells (75% wet basis).

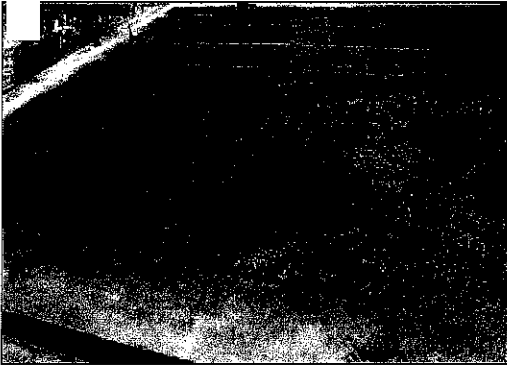

Fermented cocoa beans will be placed on the floor and using sun as drying medium.

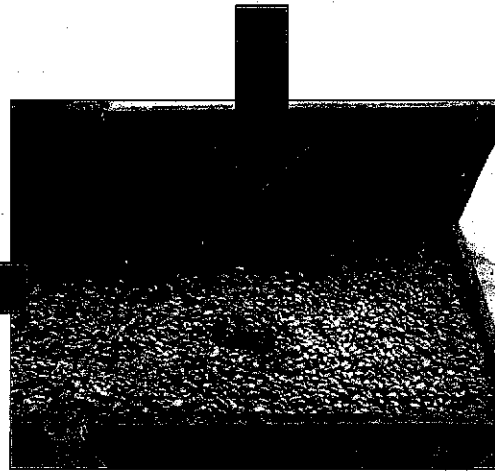

Cocoa beans will be keeping for fermentation (50 – 60% wet basis).

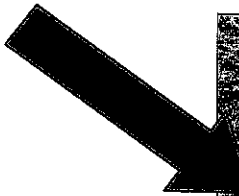

Cocoa beans after drying process finished.

Figure 2.4: Cocoa Beans Drying Process Flow

There are 3 ways of cocoa bean drying process have been applied. The ways are:

a) Sun drying

The cocoa beans will be spread out in the open air (See Appendix A), on racks or directly on the ground. Many farmers are using this method to dry their cocoa beans. This is the best method of drying cocoa beans it is simple, easy to set up and low cost. From the research about this method, the most efficient way is sun drying with cocoa beans on the concrete floor. The cocoa beans must be dried 36 hours non-stops on daily. Although this method is ideal way of drying but the process takes a long time for 3 to 4 days. This method also needs more manpower to make sure the uniform drying of cocoa beans and also to observe the drying process. If there is suddenly rain or cloud rains block the sun, there is the big problem for the cocoa bean drying process.

b) Drying using sun cabinet

This way has been introduced after the research by expertise to avoid the uncontrolled whether condition. Cocoa beans will be put into the box (made from transparent plastic) and the box will be placed under the sun. This technique can avoid the rain problem because the box will prevent the water from going to the cocoa beans. The heat in that box will be quite similar with heat from sun drying and the temperature is about 40°C. The disadvantage is the drying process cannot be done during raining.

c) Artificial hot air drying

This method has been introduced to overcome the whether condition. This process is using such as petroleum, gases or woods as a heat source. The cocoa beans will be placed onto the heat source. While more controllable this method carries a risk on tainting the beans with a smoky beacon flavour, insufficient browning and higher acidity because smoke from heat source directly contact with the cocoa beans. The price of the heat sources also become the problem for the farmers.

There are several steps that need to be control to produce good quality of the cocoa beans and maintain the aroma while drying process. The steps are:

- The temperature while drying the process must not exceed 60°C.
- The maximum thickness of the cocoa beans has been spread out for sun drying is 5 cm and for artificial hot air drying is 10 cm.
- The cocoa beans must be spread out again after 8 hours of drying especially for cocoa beans that have been attached while drying process.
- The cocoa beans must be mixed up again every 2 hours to get the uniform drying process.

2.5 Moisture of the cocoa bean

As mentioned before, fresh cocoa bean from trees has 50 – 60% moisture content. The purpose of the drying process is to reduce the moisture content of cocoa beans to 7 – 8%. The safe moisture content as indicated in Malaysia Dried Cocoa Standard is 7.5%. Drying process will helped to achieve the moisture content target and produce good quality and aroma of cocoa beans.

Figure 2.5 shows people use moisture indicator to determine present of water in the cocoa beans



Figure 2.5: Moisture indicator

There is also formula to determine moisture content in cocoa beans. The formula is:

$$V = [a - b / c] \times 100 \quad (\text{Eq. 2.1})$$

where:

- a = dish mass with sample before drying (kg)
- b = dish mass with sample after drying (kg)
- c = mass of the sample taken for analysis (kg)
- V = water content in percentage %

We also can calculate sample moisture of cocoa beans. The formula is:

$$X = \frac{m_t - m_{d.m}}{m_o - m_{d.m}} = \frac{M_t}{M_o} \quad (\text{Eq. 2.2})$$

where:

- X = sample moisture (kg_{w.} / kg_{total w.})
- m_t = mass of the sample in time (kg)
- m_{d.m} = dry matter mass of the sample (kg)
- m_o = mass of the sample before drying (kg)

Velocity of drying also can be calculated. The formula is:

$$N = dX / dt \quad (\text{Eq. 3})$$

where:

- N = drying velocity (kg_{w.} / kg_{total w.} h)

2.6 Sungai Klah Hot Springs

Sungai Klah Hot Springs is located at Sungkai, Perak (See Appendix B). Currently this place used for tourism and recreation. Many visitors from Malaysia and other countries came to this place to enjoy natural hot water here. This hot springs existed by the ground water being heated by the hot rock and the hot water come out to the surface by the difference of the pressure. In Sungai Klah Hot Springs, there is more than 100 sources of hot water. The conductive zone (See Appendix C) has been marked by the Mineral and Geosciences Department Malaysia by using geophysics technique. The equipment that they used to detect the conductive zone around Sungai Klah Hot Springs is EM (Electromagnetic SIROTEM) as in Figure 2.6 and software SURFER version 7.

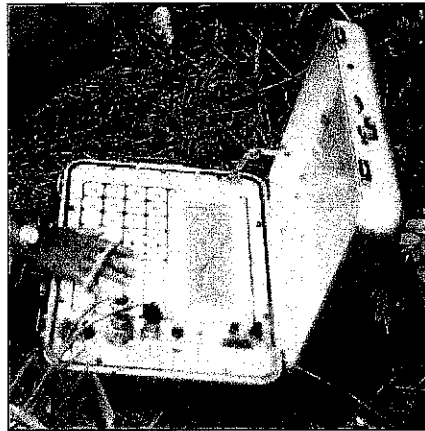

Figure 2.6: Electromagnetic SIROTEM

The average temperature for most of the pond there is 40 - 50°C. The source of hot water in every pond there comes from one reservoir where the temperature of hot water at the reservoir is 90 - 105°C. Basically people will have their activities such as bathing and reflexology in various types of pond. People even can boil eggs in those certain areas since the water is hot and the time taken is about 5 – 7 minutes. This hot springs also located highest places compare with other hot springs in Malaysia which is 200ft from sea level. This hot springs also have the lowest sulphur quantity compare with others which is about 0.005.

CHAPTER 3

METHODOLOGY

3.0 METHODOLOGY

The project basically is designing the harnessing hot spring's energy system for cocoa beans drying. The design of the system will equipped with meshed trays, drying house and also the piping in order to dry the cocoa beans. For completing the project, there are several methodologies need to be done. The project will start with literature review, visiting Mineral and Geosciences Department Malaysia, gathering design standard and specifications, pre-designing the hot spring's energy harnessing system, visiting Cocoa Board Malaysia, drying experiment on the fermented cocoa beans, calculation related to the design and lastly designing the system.

Softwares used for this project are AutoCAD, Microsoft Word and Microsoft Excel. Equipments used for the experiment are meshed bowl, drying oven, stop watch and weight indicator. Figure 3.1 will illustrate the flow chart of the project.

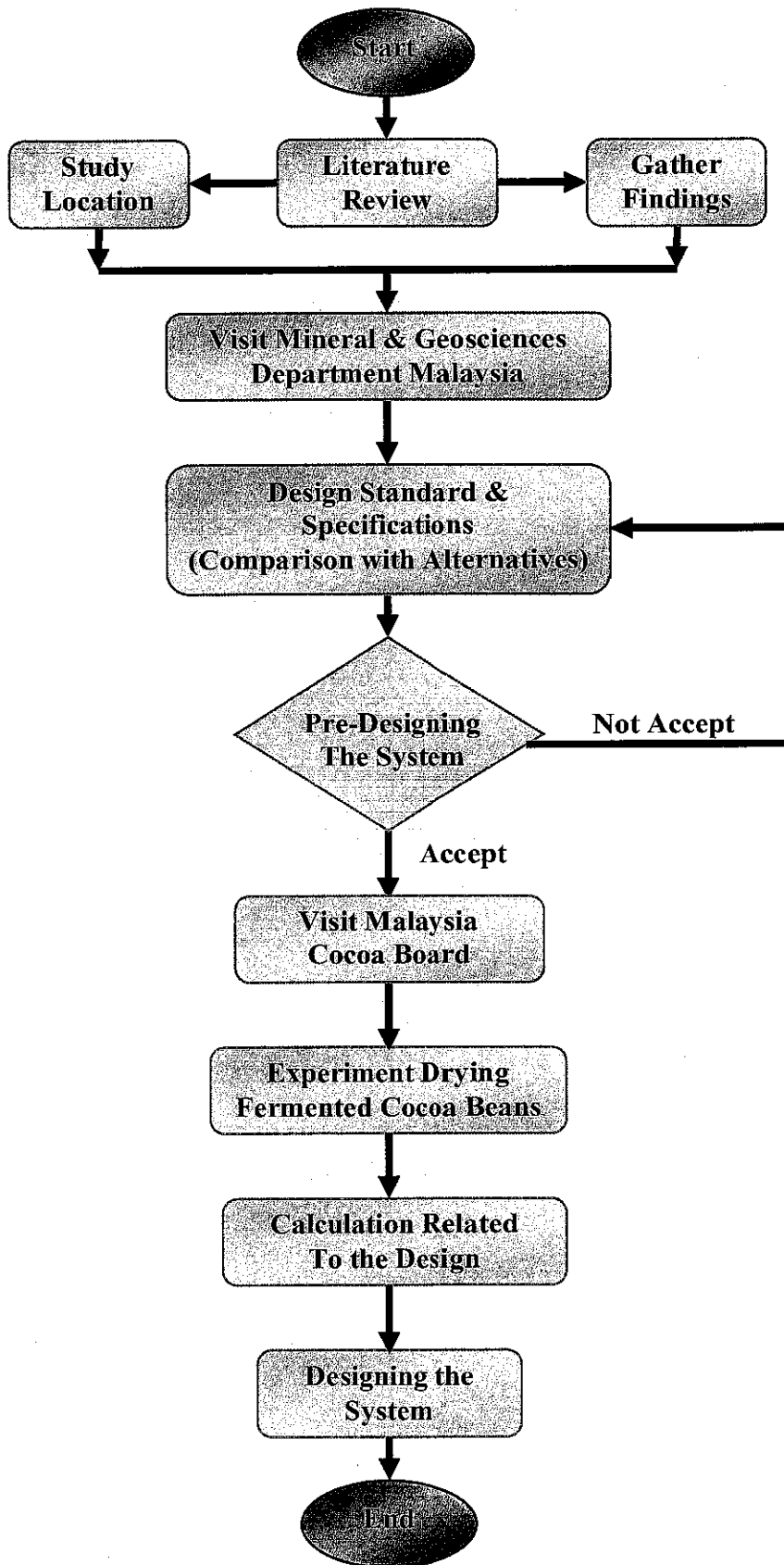

Figure 3.1: Flow chart of the project

3.1 Start the Project

The project will start with the proposal to the supervisor. Rough idea of this project is to design system that can harness hot water from hot springs and then used it for industrial application. The focus of this project is to come out with the design that can harness hot springs energy for cocoa beans drying. The calculation need to be done in order to determine the estimation value for the design.

3.2 Literature Review

First of all, understands the current applications that are using energy from earth (geothermal). Studied the potential places in Malaysia which have potential hot spring's energy and decided the location according to the nearest distance between cocoa farm and hot springs. Journal, engineering books anything relevant to the project are reviewed.

3.3 Visit Mineral and Geosciences Department

In order to have more understanding regarding hot springs selected, the visit has been done to Mineral and Geosciences Department Malaysia. Explanations regarding the selected hot springs are given by one of their officer.

3.4 Design Standard and Specifications

Before started the pre-designing, design standard and specifications for drying cocoa beans must be determined. Alternative solutions are being determined in this stage. These standards have been gathered by using published standards engineering books, experiences and experts. The standards are:

- i. Location for the project
- ii. Moisture content
- iii. Temperature of the hot water and drying house
- iv. Drying house requirements
- v. Drying procedure
- vi. Drying rates
- vii. Heat transfer
- viii. Material selection

3.5 Pre-Designing the System

Pre-designing the system shows the draft on the system and also how the system work. The unknowns in the design must be determining using the calculations.

3.6 Visit Malaysia Cocoa Board

In order to have more understanding on drying cocoa beans process, the visit has been done to Malaysia Cocoa Board. The fresh and fermented cocoa beans been taken from them in order to do the experiment regarding the drying process.

3.7 Experiment Drying Fermented Cocoa Beans

This experiment is being done in order to determine the drying curve and drying rate curve for cocoa beans at specified temperature. The procedure of this experiment is in the Appendix D. Discussion has been made after the graph of the experiment being plotted.

3.8 Calculation Related to the Design

There are several calculations must being done to determine the unknown in the system. The calculations involved are length of the steel piping inside the drying house, heat transfer in the system and also time of drying.

3.8.1 Length of Steel Pipe

Length of pipe must be determined before designing the system. The volumetric and mass flow rate being calculated and then using the two equations of heat transfer we can determine the length needed.

3.8.2 Heat Transfer in the System

Heat transfer can be determining by calculated the total resistance in the system using heat transfer coefficient and thermal conductivity of the steel. The difference in temperature will be dividing with the total resistance in the system.

3.8.3 Time of drying

The drying time can be calculated using the heat transfer value that we get from previous calculation, reduction mass of water and also latent heat of water at specific temperature.

3.9 Designing the System

Using the value from the calculations, the author now can design the system. The technical drawing of racks, meshed trays, drying house and overall system being made using AutoCAD. The function of equipment and how the system operated also being explain.

3.10 End of Project

As the end of the project, the final report of Design Harnessing Hot Spring's Energy for Cocoa Beans Drying is completed. For future study, there are some recommendations that have been made.

CHAPTER 4

RESULTS AND DISCUSSIONS

4.0 RESULTS AND DISCUSSIONS

4.1 Location Selected

After done the research regarding hot springs in Malaysia, the author has selected Sungai Klah Hot Springs as location for this project. The details regarding this hot spring are in Chapter 2.6 (Literature Review). For additional information, Malaysia is the 4th largest producer of cocoa in the world while Perak is the 3rd largest producer in Malaysia after Sabah and Pahang. That's the reason the author selected Sungai Klah Hot Springs for this project since the location near to the several cocoa farms in that area and doesn't need cost for transportation.

4.2 Data Gathering

All of the search and findings that related to this project are stated in Chapter 2 (Literature Review).

4.3 Visiting Mineral and Geosciences Department Malaysia

In order to have more understanding regarding location project, the author has done the interview with Mr. Dzazali b. Ayub, officer from Mineral and Geosciences Department, Perak, Malaysia. During the visit, he explained how the Sungai Klah Hot Springs formed, the temperature for hot water in that area and also advises to protect the resources. The details also stated in Chapter 2.6 (Literature Review).

4.4 Design Standard and Specifications

Before starts with standard, the problems have been identified which are the time taken for cocoa beans to dried is about 40 hours using sun drying which means 4 days taken sun from 8 a.m. until 6 p.m. The second problems are weather condition is

uncontrollable. The third problem is the cost of energy for fuel and gases for artificial drying used by the farmer who want to maximize their products are too high. For the design standard and specifications, the author has summarized the details as below.

i. Location of the project

From all those hot springs phenomenon appears in our country, Sungai Klah Hot Springs has been chosen as a location for the project.

ii. Moisture content

Details about moisture content in Chapter 2.5 (Literature Review). Target for the final moisture content of cocoa beans after drying is from 50 – 60% moisture content to 7.5 %.

iii. Temperature of hot water and drying house.

Temperature of hot water that has been taken from the reservoir is 70 °C and the target temperature inside drying house is 50 °C.

iv. Drying house requirements

There are several requirements for the drying house which are:

- Trays for cocoa beans for drying process must be meshed in order for uniform drying.
- Air ventilation system to remove hot air that being used for drying.
- Thermometer to detect temperature inside drying house.
- Piping inside drying house with good thermal conductivity.

v. Drying procedure

Fermented cocoa beans will be placed on the meshed trays. Hot water will flow inside piping and the fan will be used to circulate the dry air.

vi. Drying rates

Drying rates related to time need for each drying. The details are in Chapter 4.8.3 (Engineering Calculations).

vii. Heat transfer

Heat transfer related to the heat needed for each drying. The details are in Chapter 4.8.2 (Engineering Calculations)

viii. Material selection

The most important material that must be selected is piping inside the drying house. The selection must consider the thermal conductivity, cost of material and availability in the market. In this project, the author selected steel for his first estimation calculation with thermal conductivity 46 W/m.K.

4.4.1 Alternative solution

There are several ways for cocoa beans drying process (Chapter 2.4 Literature Review). The comparison between alternative ways of drying and the hot springs drying system has been made by analysis with the problems that have been facing. Table 4.1 shows the comparison between all alternative drying and the capability of the system that will be design in this project.

Types of drying	Effectted by weather	24 hours working	Additional energy cost	Time of drying more than 30 hours	Product effected by combustion
Sun Drying	Yes	No	No	Yes	No
Sun Cabinet Drying	Yes	No	No	Yes	No
Artificial Drying	No	Yes	Yes	No	Yes
Hot Springs Drying	No	Yes	No	No	No

Table 4.1: Comparison with all types of cocoa beans drying system

4.5 Pre-Designing the system

In order to pre-design the hot springs harnessing system for cocoa beans drying, there are several equipments that need to be included in the system. The equipments are:

- i. Hot spring borehole - Place for piping to collect hot waters from reservoir
- ii. Hot water pump - To pump hot water through the system
- iii. Outside piping - Hot water route (outside)
- iv. Control system - Meter reading temperature (drying house) and switch to activate air ventilation system
- v. Connection valve - To control hot water volume inside drying house
- vi. Steel piping - Route hot water flow inside drying house.
- vii. Thermometer sensor - To read temperature inside drying house.
- viii. Air ventilation system - To remove drying air when temperature inside drying house exceeding limit
- ix. Drying house - Place to distributed drying air to the product
- x. Meshed tray - Place for cocoa beans in drying house.
- xi. Re-injection pipe - To inject circulated hot water into injection well
- xii. Fan - Circulating hot air through the cocoa beans

4.5.1 Drying house process flow

The hot springs harnessing system for cocoa beans drying is shown in Figure 4.1. Basically the hot water will be pumped using hot water pump. Then, the hot water will flow through outside piping and control system. The control system will give reading the temperature of the hot water. Connection valve will be open and hot water will flow inside steel pipe. Hot water will remove the heat through the pipe and then fan will be used to circulate drying air to dry the cocoa beans. Thermometer inside drying house will measure temperature in drying house. The air ventilation system will be open automatically to remove air inside drying house if temperature exceeding the limit. Hot water will be stop supply from outside. The hot water will flow out through re-injection pipe and going to re-injection well.

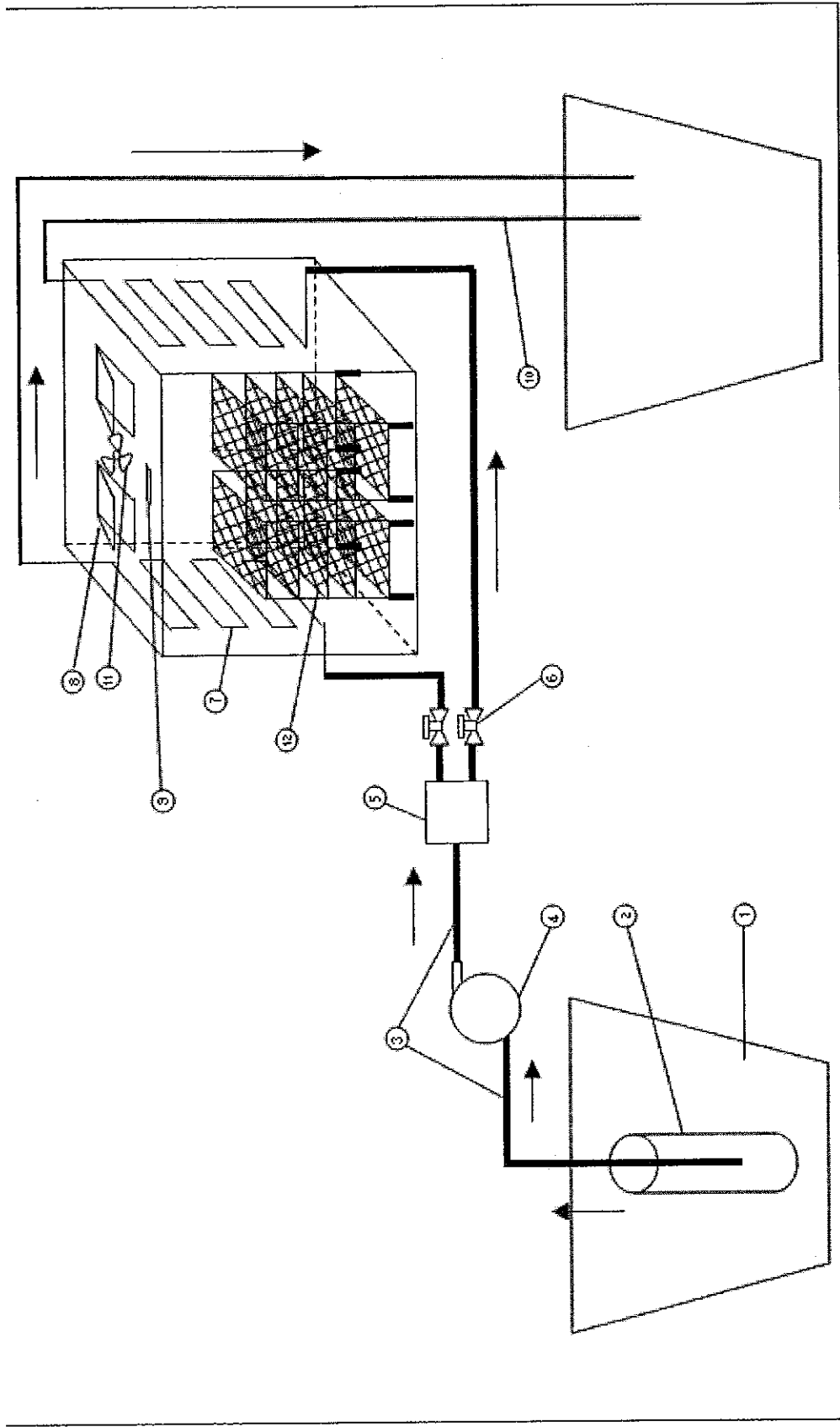

- | | | |
|-------------------------|-------------------------------|----------------------------|
| 1. Reservoir | 5. Control system | 9. Thermometer |
| 2. Hot Springs Borehole | 6. Connection Valve | 10. Re-injection Pipe |
| 3. Outside Piping | 7. Inside Piping (Steel Pipe) | 11. Fan |
| 4. Hot Water Pump | 8. Air Ventilation System | 12. Racks and Meshed Trays |

Figure 4.1: Pre-designing Hot Springs Harnessing System for Cocoa Beans Drying

4.6 Visiting Malaysia Cocoa Board

Author has done the visit to Malaysia Cocoa Board in order to get sample of cocoa beans and also want to have more understanding regarding cocoa beans drying process. The author has been given explanations by Dr. Lee and Mrs. Hajjah Faridah. The process of cocoa beans drying has been explained as stated in Chapter 2.4 (Literature Review). The sample of fresh cocoa fruits also been taken from there in order for the author to do the experiment in determining the drying curve for cocoa beans.

4.7 Experiment Cocoa Beans Drying

The experiment on cocoa beans drying process (Appendix E) has been done by the author in order to determine the drying curve and drying rate curve of cocoa beans. The experiment has been done according to the procedure in Appendix C. The result for that experiment is stated in Table 4.2 and the graph reduction water against time in Figure 4.2.

Mass meshed bowl, w_0 = 117.525 g

Mass bowl + wet fermented cocoa beans, w_1 = 267.525 g

Temperature of the oven = 50 °C

No. of hours	Mass while drying, w_2 (g)	Weight of cocoa beans (g)	Reduction of water (%)	Moisture content (%)
1	247.927	130.402	13.065	13.07
2	232.509	114.984	11.823	23.344
3	221.394	103.869	9.667	30.754
4	214.475	96.950	6.662	35.367
5	209.491	91.966	5.141	36.689
6	205.581	88.056	4.252	41.296
7	202.538	85.013	3.456	43.325
8	199.900	82.264	3.234	45.157
9	198.835	79.701	3.115	46.866
10	198.158	77.495	3.018	48.337

Table 4.2: Results for cocoa beans drying experiment at 50 °C

For reduction of water and moisture content, the calculations as stated below:

$$\text{Reduction of water (\%)} = \frac{W_n - W_{n+1}}{W_n - W_0} \times 100 \quad (\text{Eq. 4.1})$$

$$\text{Moisture Content (\%)} = \frac{W_n - W_{n+1}}{150} \times 100 \quad (\text{Eq. 4.2})$$

The data has been calculated and 2 graphs can be plotted to show the relation of reduction of water and moisture content against time.

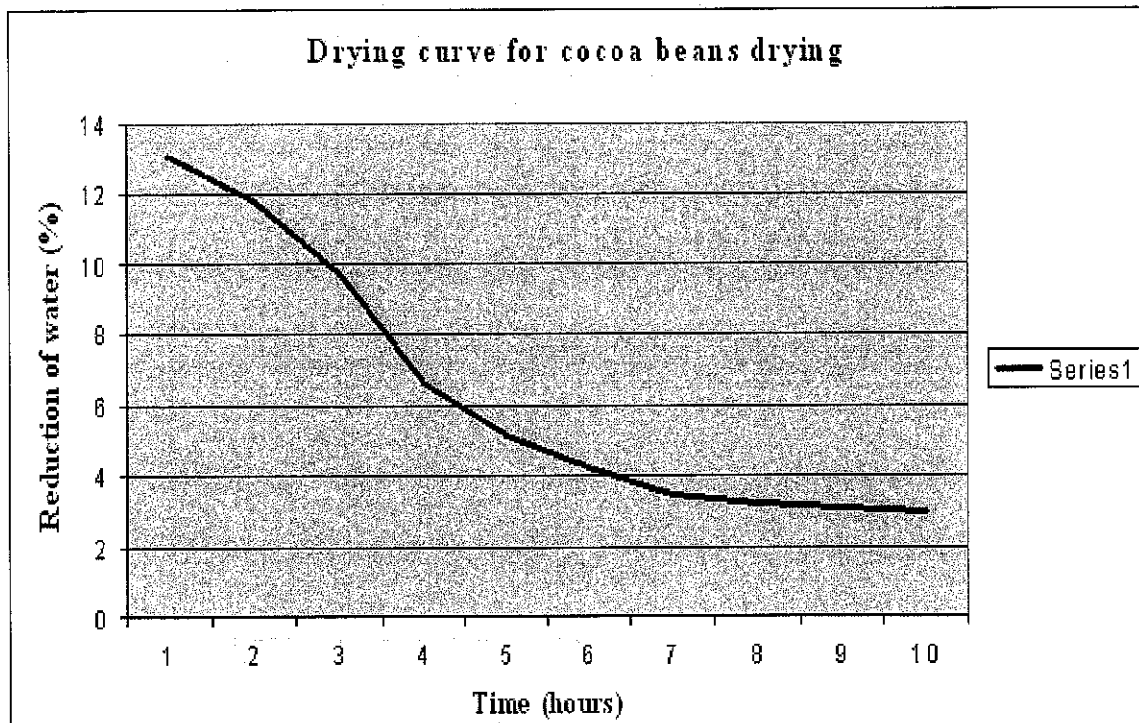

Figure 4.2: Graph reduction of water versus time

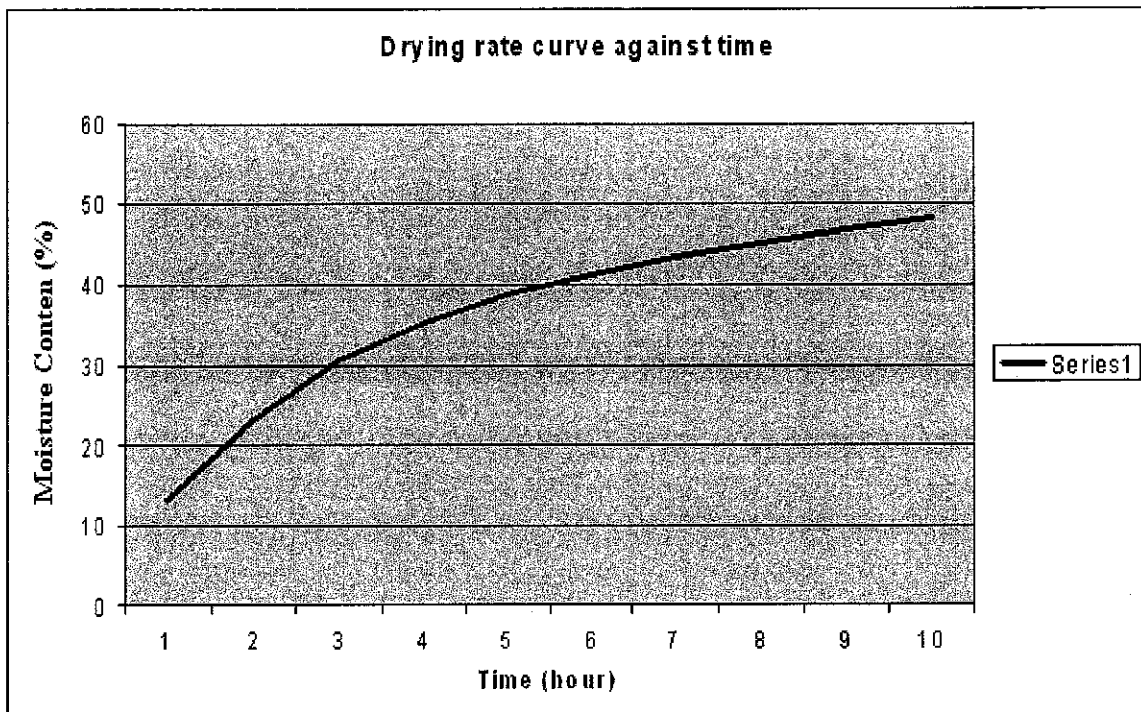

Figure 4.3: Graph moisture of content of water versus time

From the Figure 4.2, there are big differences between reduction of water on the first and last 4 hours for the experiment. For the first 4 hours of experiment, rate reduction of water inside the fermented cocoa beans is so fast. This is because the water in the layer close to surface comes out first. The rate become slower after that and at the last 4 hours in the experiment, the rate reduction of water becomes almost constant. This is because the water from the inside cocoa beans have difficulties to pass through the layer on cocoa beans.

For Figure 4.3, the moisture content increase greatly in initial 5 hours but the rate increase slowly after that and almost become constant. The higher moisture content been reduced in initial experiment also depends on the water easily come out from layer near to the surface. The lower moisture content being reduced since the water need to pass through before come out.

4.8 Engineering Calculations Related to the Design

There are several unknowns that need to be known before the author can continue working on the design. In order to determine the unknowns, the author used the engineering calculations as the solutions for all unknowns in this project. Basically with these calculations, the value of unknowns is just first estimation of the project, not the actual value.

Before the author start the calculations, the author makes the figure 4.4 and 4.5 in order for him do the first estimation.

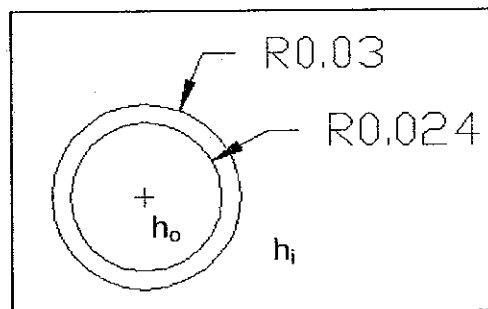

Figure 4.4: Wall thickness of steel pipe

This figure shows the radius for steel pipe that going to use in this project. Inner radius is 0.024 m, the outer radius is 0.03 m, h_o is heat transfer coefficient inside the pipe and h_i heat transfer coefficient outside the pipe.

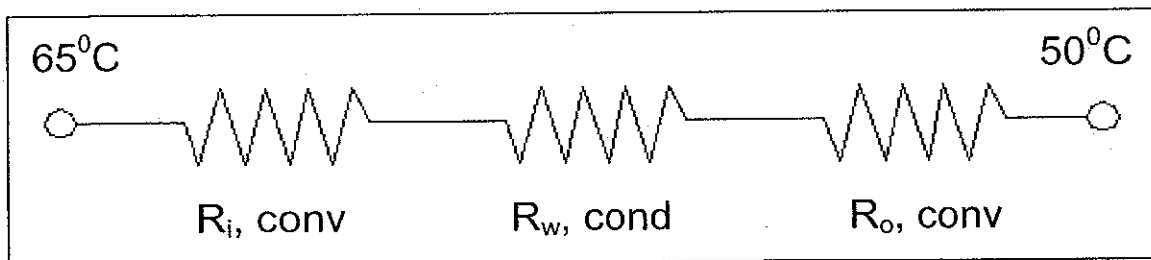

Figure 4.5: Resistance in the system

This figure shows the total resistance in the system. First resistance is between the hot water itself which is natural convection, second resistance is the between hot water and steel pipe which is conduction and the last resistance is between hot dry air which is the forced convection. All the resistances are in series and the initial temperature is 65 °C while the final temperature is the temperature inside drying house which are 50 °C.

4.8.1 Length of the steel pipe

Hot water will flow in the steel pipe with velocity, $v = 0.2 \text{ m/s}$.

Volumetric flow rate of hot water, V

$$\begin{aligned} V &= v.A \\ &= 0.2 \times (\pi r^2) \\ &= 0.2 \text{ m/s} [\pi \cdot (0.03 \text{ m})^2] \\ &= 5.655 \times 10^{-4} \text{ m}^3/\text{s} \end{aligned}$$

Mass flow rate of hot water, m_w

$$\begin{aligned} m_w &= \rho.V \\ &= 998.2 \text{ kg/m}^3 \times 5.655 \times 10^{-4} \text{ m}^3/\text{s} \\ &= 0.5646 \text{ kg/s} \end{aligned}$$

To determine length of steel pipe used below information and equation heat transfer for convection,

$$q_{\text{conv}} = m_w.c_p.(\Delta T) \text{ ----- (1)}$$

$$q_{\text{conv}} = h_i.A.(\Delta T) \text{ ----- (2)}$$

$$(1) = (2)$$

$$\cancel{m_w.c_p.(\Delta T)} = \cancel{h_i.A.(\Delta T)}$$

$$0.5646 \text{ kg/s} \times (4181 \text{ J/kg.K}) = 20 \text{ W/m}^2\text{K} \times 2\pi.(0.03\text{m})L$$

$$L = 62.6 \text{ m} \approx \mathbf{63 \text{ m}}$$

4.8.2 Heat Transfer in the System

To calculate total resistance in the system used below information.

$$\text{Heat transfer coefficient of hot water, } h_0 = 5000 \text{ W/m}^2\cdot\text{K}$$

$$\text{Heat transfer coefficient of drying air, } h_1 = 20 \text{ W/m}^2\cdot\text{K}$$

$$\text{Thermal conductivity of steel pipe, } K = 46 \text{ W/m}\cdot\text{K}$$

$$\text{Inner radius of steel pipe, } r_0 = 0.024 \text{ m}$$

$$\text{Outer radius of steel pipe, } r_1 = 0.030 \text{ m}$$

$$\sum R_{th} = \frac{1}{h_0 \cdot A_0} + \frac{\ln\left(\frac{r_0}{r_1}\right)}{2\pi K L} + \frac{1}{h_1 \cdot A_1}$$

$$\sum R_{th} = \frac{1}{5000[2\pi(0.024)(63)]} + \frac{\ln\left(\frac{0.03}{0.024}\right)}{2\pi(46)(63)} + \frac{1}{20[2\pi(0.03)(63)]}$$

$$\sum R_{th} = 4.24331 \times 10^{-3} (\text{W} / \text{K})^{-1}$$

Heat transfer in the system,

$$q_{total} = \frac{\Delta T}{\sum R_{th}} = \frac{338 - 323}{4.24331 \times 10^{-3}}$$

$$= \frac{338 - 323}{4.24331 \times 10^{-3}}$$

$$q_{total} = 3534.98 \text{ W}$$

4.8.3 Drying Time for the System

To calculate drying time, we must calculate reduction of water in the system. The fermented cocoa beans have 60% water content and we want to reduce it to 8% water content (residual).

Wet mass of fermented cocoa beans	= 200 kg
Mass of water inside cocoa beans (initial)	= 120 kg
Mass of water inside cocoa beans (final)	= 16 kg
Reduction of water, m	= 104 kg
Final mass of dried cocoa beans	= 96 kg
Latent heat of water at 50 ⁰ C, q_L	= 2378 kJ/kg

$$q_{total} = \frac{m \times q_L \times 1000}{time(s)}$$

$$3534.98 = \frac{104 \times 2378 \times 1000}{time(s)}$$

$$time(s) = \frac{69961.36s}{3600s}$$

$$time = 19.43hours$$

Time of drying \approx **19.5 hours**

All the values for unknowns that have been determined using all the calculations are just first estimations of this project. In order to have the actual data, the experiment of drying cocoa beans must be done and the data regarding reduction of moisture content for every minute must be taken.

4.9 Design of the System

The length of steel pipe, heat transfer involved in the system and also drying time needed using this system has been determined. The designs have been made using the AutoCAD. Figure 4.6 shows the orthographic view of the racks, figure 4.7 shows orthographic view of meshed tray and figure 4.8 shows how the meshed tray being placed on the rack, figure 4.9 shows orthographic view of drying house and figure 4.10 shows the system. Units for dimension are in meter (m).

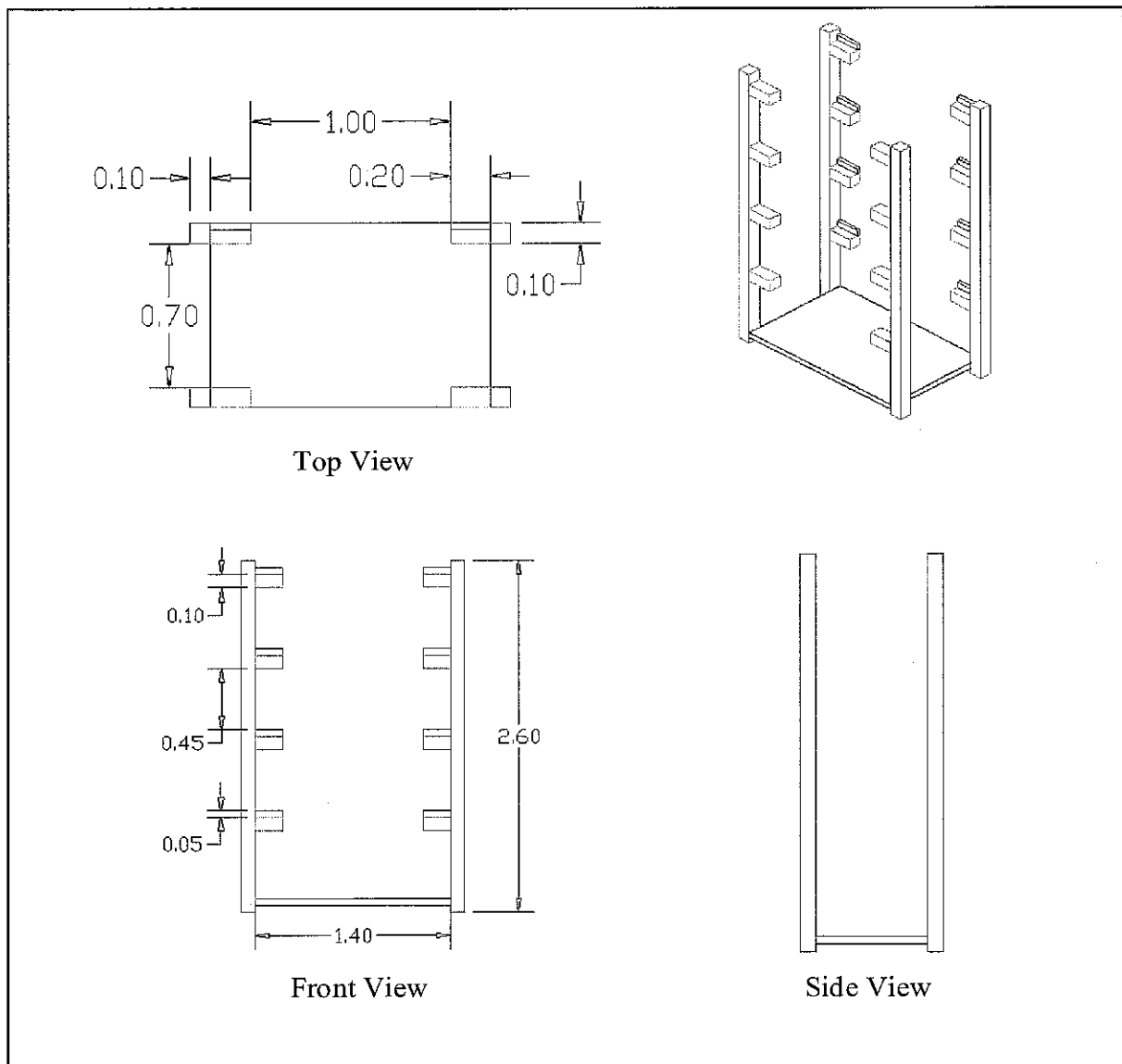

Figure 4.6: Orthographic View of Rack

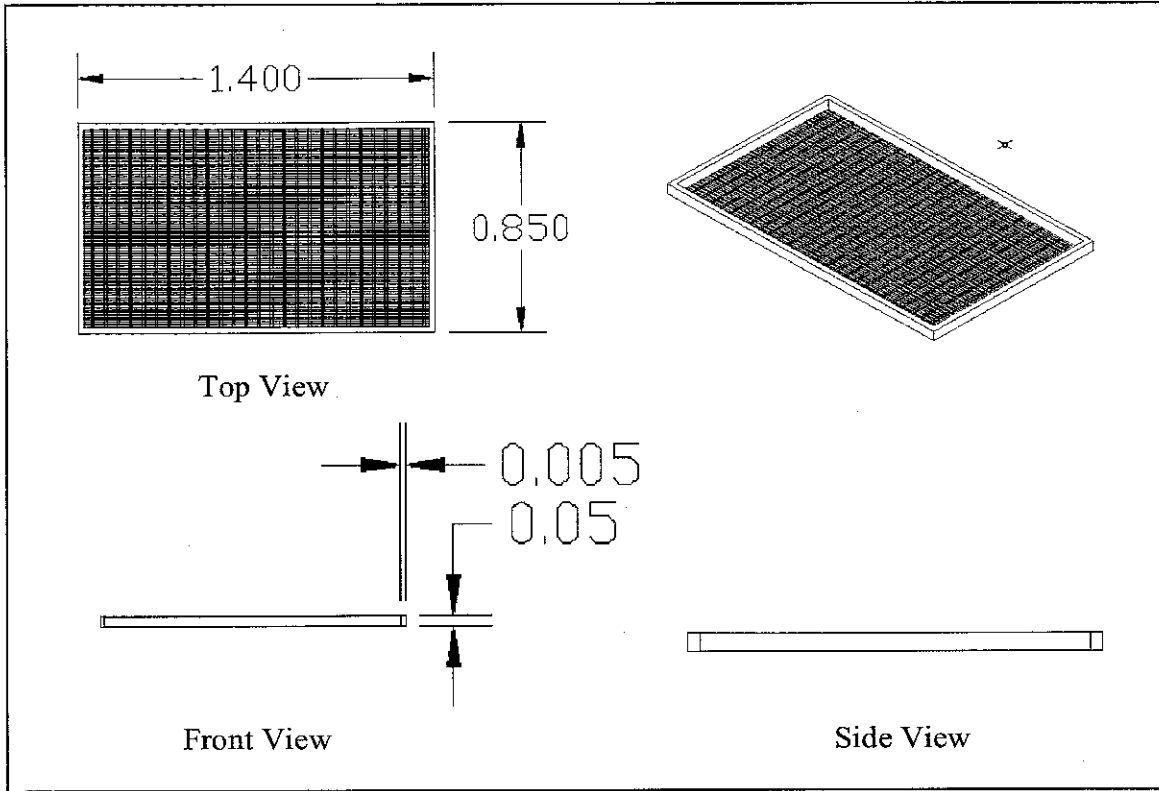

Figure 4.7: Orthographic View of Meshed Tray

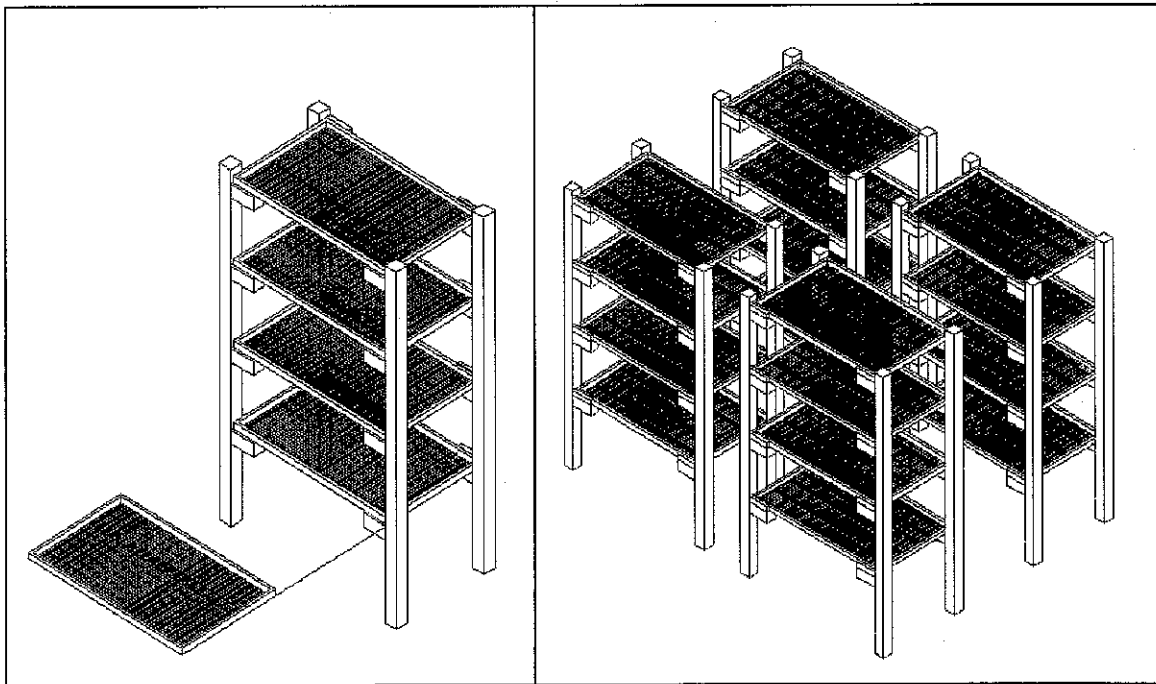

Figure 4.8: Position trays on the rack

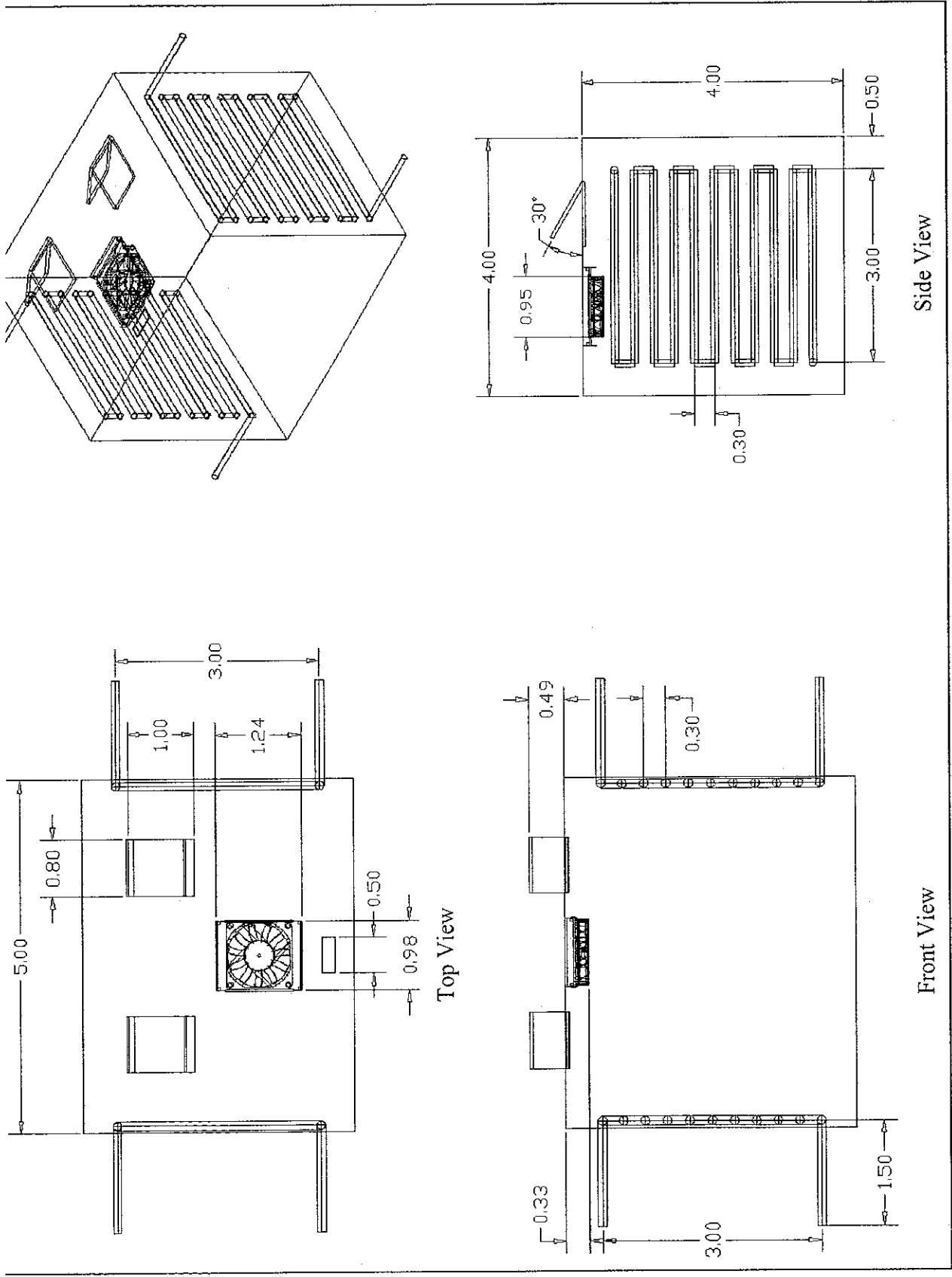

Figure 4.9: Orthographic View of Drying House

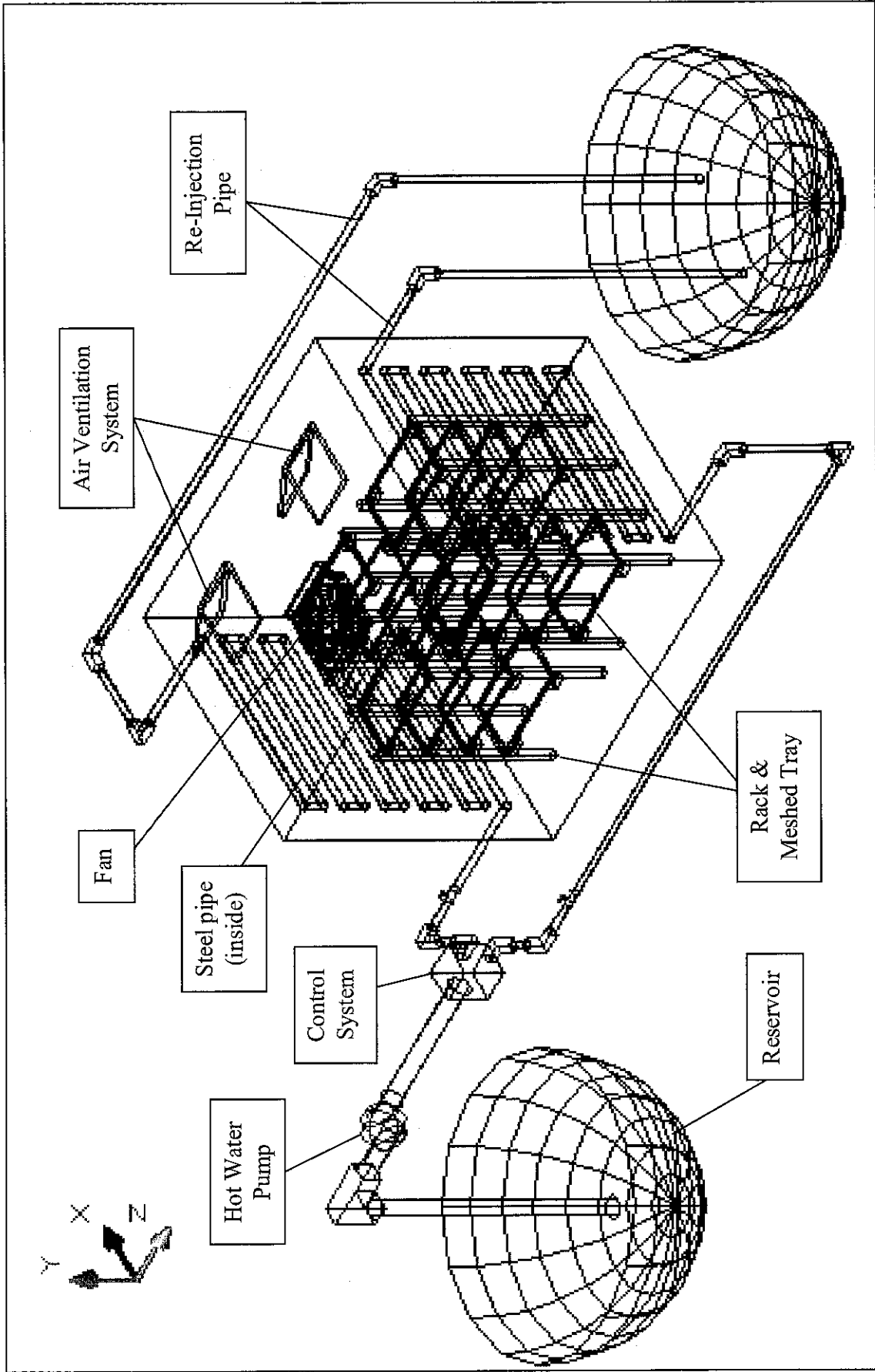

Figure 4.10: Design of the System

4.10 Discussions Regarding the Design

The process flow of this design is same as in Drying House Process Flow (Chapter 4.5.1). Hot water will be taken from the reservoir and then flow from insulated pipe outside the drying house and then continue flowing through the steel pipe. The hot water will transfer the heat into the drying house through the steel pipe in order to get the temperature needed which is 50 °C. The fan will be used to circulate the hot dry air from bottom to top for drying the cocoa beans. If the temperature in the drying house exceeding limit after thermometer gets the reading, the air ventilation system will be open and hot water stop supply from the outside. The dimensions of the designs (in meter) which are for racks, meshed trays and drying house also have been mentioned give the details about the equipment used in the system (Chapter 4.9).

The first estimation values of length steel pipe, heat transfer needed and time of drying has been using in order to make the design for this system. The value is not the actual one since further experiment need to be done to get the actual value.

4.11 Corrosion Prevention

One of the major problems that being identified is the potential for steel pipe to corrode. This is because there is sulphur in the hot water that can assist to the corrosion. Below are the several suggestions that have been finding in order to protect the pipe from corrosion.

- i. Alloying the steel with alloy element (e.g. 2% Mn) to increase the resistance of the steel from corroded.
- ii. Reduce acidity for the hot water with injecting corrosion inhibitors.
- iii. Reduce diffusions of ions in hot water pipe by adding chemical substance that can slow the corrosion process.
- iv. Apply cathode protection by using other active metal (e.g. Aluminium) connected to the steel pipe and apply current between pipelines and another active metal.

CHAPTER 5

CONCLUSIONS AND RECOMMENDATIONS

5.1 CONCLUSIONS

The main objective of this project is to design the harnessing hot spring's energy system for cocoa beans drying. This project basically can help people who are involve in cocoa industries such as farmers, middlemen and traders to reduce cost in operation, maintenance and also manpower since the energy price is hiking very much right now. This project also can solve the weather problems and then help to maximize the quantity of dried cocoa beans. The time of drying for cocoa beans can be reduced with this system since it can operate in 24 hours without affecting the quality of the cocoa beans.

The methodologies are being done in order to achieve the main objective of this project. The methodologies start with pre-design of the system and then experiment. The experiment of drying cocoa beans in oven with the temperature 50°C is being doing in order to determine the drying curve of cocoa beans. It is proved that the longer time taken for cocoa beans to dry compare from initial experiment since the water inside the cocoa beans need to pass through the shell before can completely dry.

The calculations have been made in order to determine the length of steel pipe, heat transfer and time of drying. The values are just for first estimations of the design. The design of the system have been made using the AutoCAD and also with the dimensions. Hopefully this design will help for implementing this system.

5.2 RECOMMENDATIONS

In the future, these are the future works that will be helped this system success to be implementing:

- Determining the actual unknowns in this project by doing further experiment.
- Experiment on drying cocoa beans with consistently taking the reading (15 minutes per reading) in order to determine the drying curve and behaviour while drying process.
- Material selection with the proper economic analysis.
- Problems determination when implementing this system and how to overcome it.
- Make the corrosion prevention in order to protect the steel pipe from corrode.

These are the some future works that being recommend by the author to continue this project. The system also can be improved using other types of alternative energy which are low cost. Hopefully this project will be implemented in the future to overcome the problems that have been facing by individual involved in cocoa industries.

REFERENCES

- 1] Geothermal Power Plants. Ronald DiPippo (2005). Elsevier Advances Technology, The Boulevard, Langford Lane, Kidlington, Oxford OX5 1GB, UK.
- 2] Geothermal Energy Utilization and Technology. Mary H. Dickson and Mario Fanelli (2003). Earthscan, 8-12 Camden High Street, London, NW1 0JH, UK.
- 3] Design and Optimization of Thermal Systems. Yogesh Jaluria (1998). McGraw- Hill series in mechanical engineering ISBN 0-07-032388.
- 4] Elements of Heat and Mass Transfer. Vijay Gupta (2005). New Age International (P) Limited, 4835/24, Ansari Road, Daryaganj, New Delhi.
- 5] Laporan Siasatan Transient Electromagnetic (TEM) Kajian Air Panas Sungai Klah, Perak. Dzazali Ayub (2005) Mineral and Geosciences Dept, Jln Sultan Azlan Shah, Ipoh, Perak.
- 6] Article modelling using a new thin layer drying model and product quality of cocoa, Journal of Food Engineering, Volume 90, Issue 2, January 2009, Pages 191-198.
- 7] Journal of Engineering Science & Technology, Vol. 3, No 1 (2008) 1-10. School of Engineering, Taylor's University College.
- 8] Journal of Cocoa Product Drying from University of Zagreb, Faculty of Food Technology and Biotechnology, Pierottijeva 6, 10000 Zagreb, Croatia
- 9] Heat and Mass Transfer. Dr.-Ing. Hans Dieter Baehr and Dr.-Ing. Karl Stephan (2006) University of Stuttgart, 70550 Stuttgart Germany
- [10] http://en.wikipedia.org/wiki/Geothermal_power
- [11] <http://www.energyquest.ca.gov/story/chapter11.htm>

APPENDICES
APPENDIX A
SUN DRYING METHOD



Appendix A (i): Sun Drying Method (on map)



Appendix A (ii): Sun Drying Method (on ground)

APPENDIX B

LOCATION OF SUNGAI KLAH, PERAK

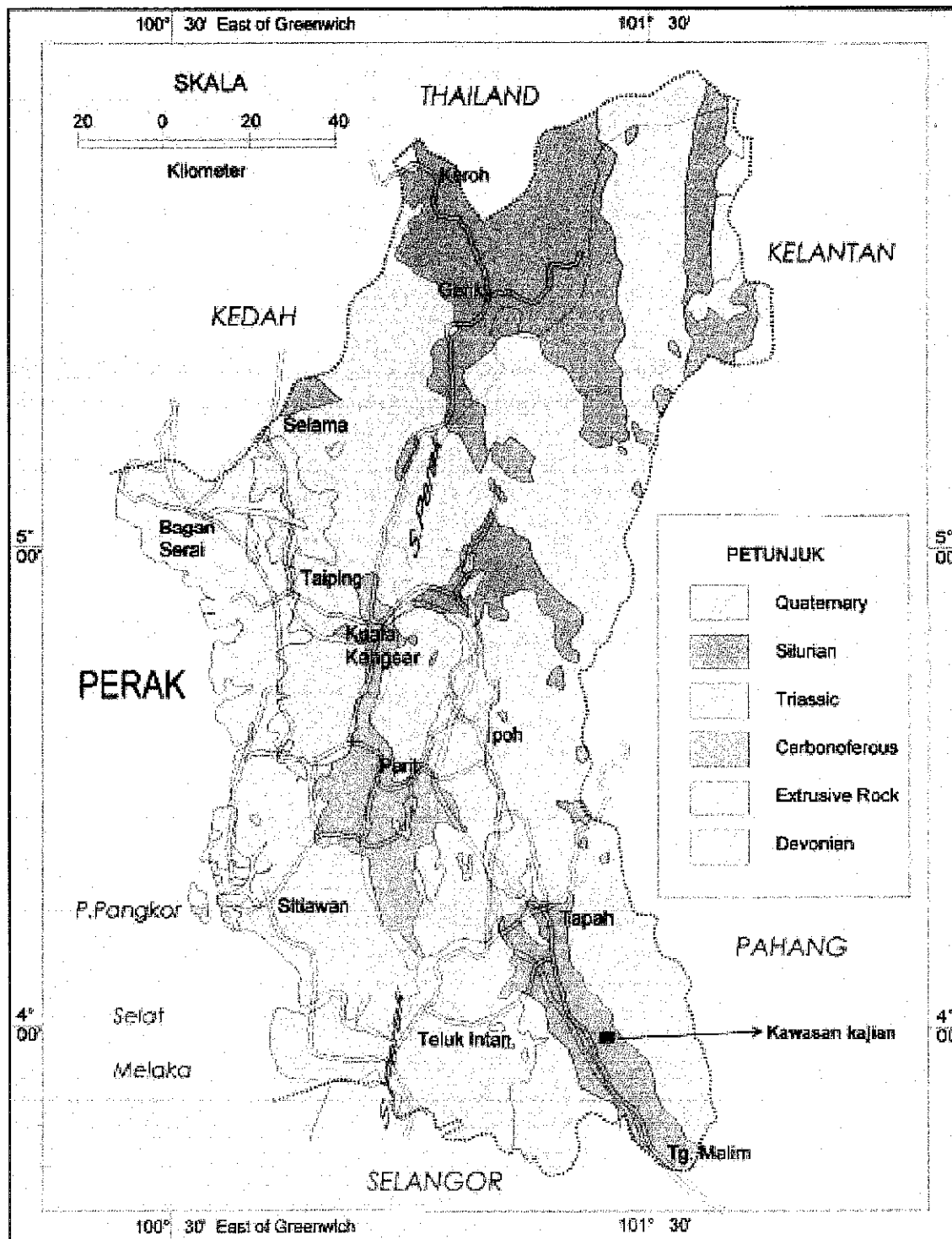

APPENDIX C

CONDUCTIVE ZONE AT SUNGAI KLAH

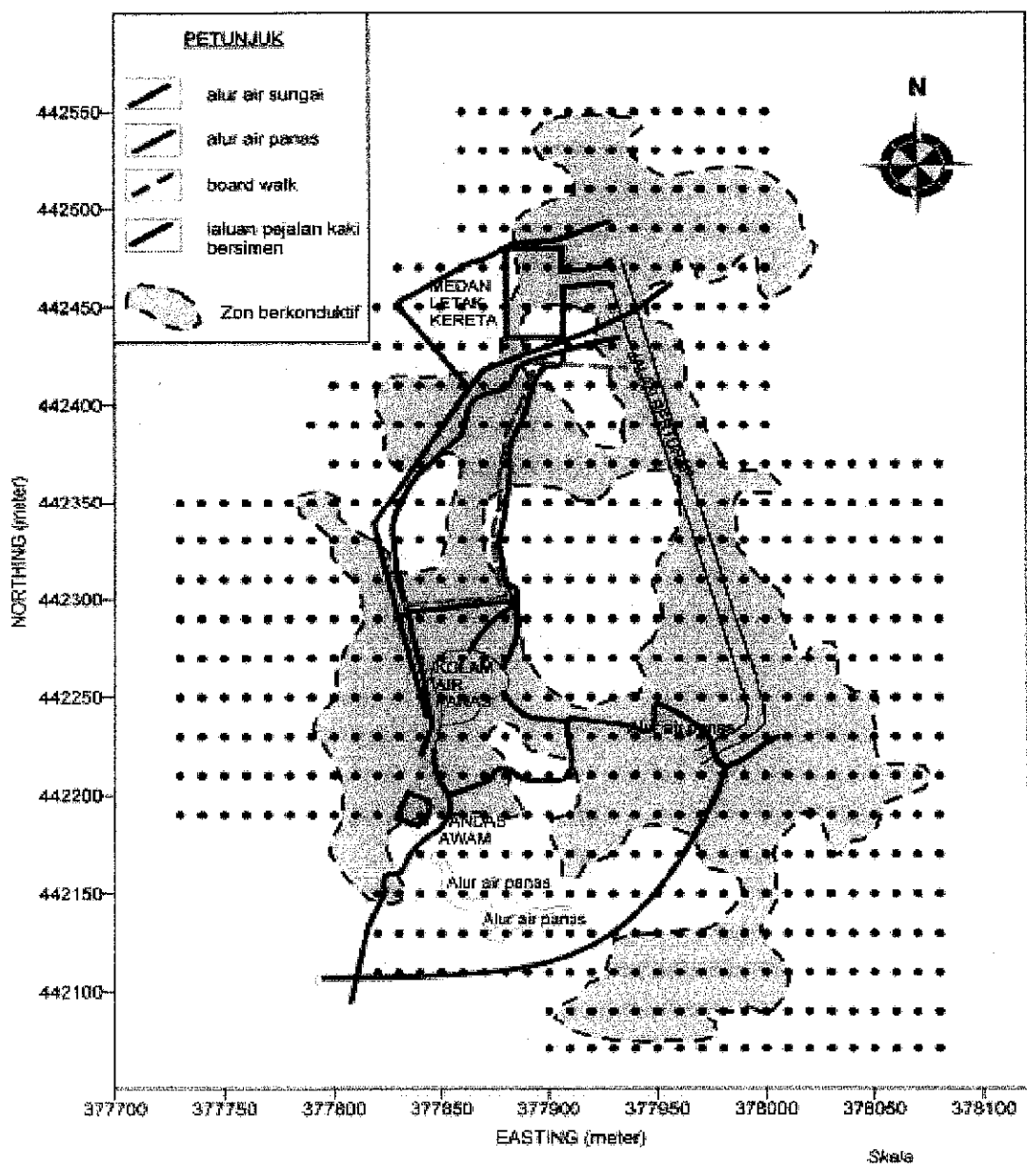

APPENDIX D

PROCEDURE FOR COCOA BEANS DRYING EXPERIMENT

The purpose of this experiment is to determine the drying curve of fresh cocoa beans. Basically there are 2 ways to determine the drying rate which are:

- Experimental at specific temperature
- Calculations using effective diffusivity at different kind of temperature

Fermented cocoa beans weight 150gram will be use. The equipment needed for this experiment:

- Oven
- Meshed bowl
- Weight measuring device
- Stop watch

After all the equipments have prepared, the experiment start with this following procedures:

- 1) Cocoa beans removed from its shell, and being kept in the dry place 2 days for fermentation.
- 2) Weight the meshed bowl, w_0 and take the reading. Put the fermented cocoa beans into the bowl and then weight again, w_1 . Take the reading.
- 3) The temperature of the oven set up to 50°C .
- 4) Put the weighted fermented cocoa beans and meshed bowl into oven and starts the stop watch. Close the oven.
- 5) After 1 hour, remove the bowl from the oven and the weight the bowl, w_2 and take the reading.
- 6) Put back again the meshed bowl with cocoa beans into ovens. Repeat again step (4) to step (6) for 10 hours.
- 7) After finished the experiment, calculate the new weight of cocoa beans for every hour by using this equation. Take the reading.

New weight of cocoa beans for every hour, $m = (w_1 - w_2) - w_0$

- 8) Then, to calculate the reduction of water for every hour, use the equation below.

$$\% \text{reduction} = \frac{m_{at1} - m_{at2}}{m_{at1}} \times 100$$

- 9) Continue calculate by replacing m_{at1} with m_{at2} and m_{at2} with m_{at3} into the equation above and tabulate the result.
- 10) Plot the graph between the reductions of water against time.

APPENDIX E
EXPERIMENT DRYING COCOA BEANS

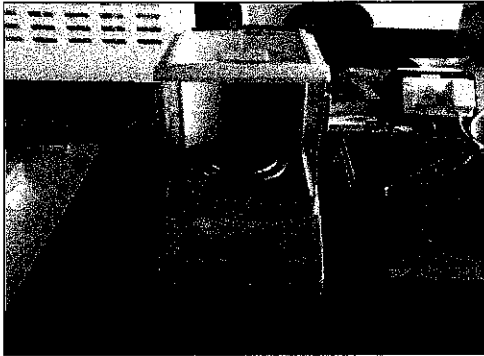

Weight Measuring Device

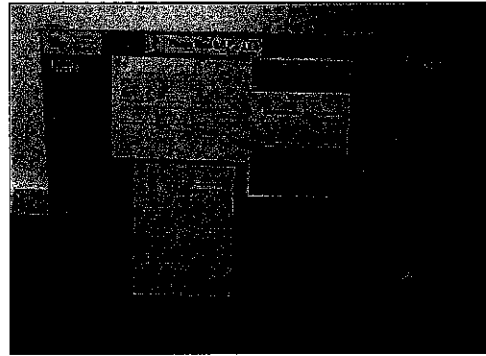

Drying Oven

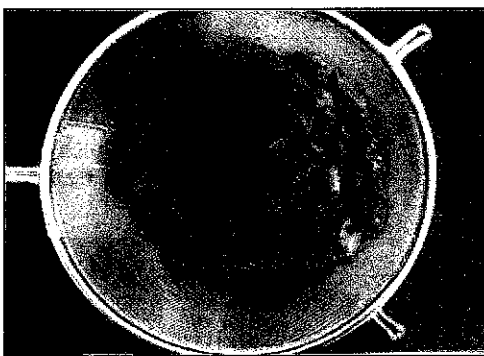

Wet fermented cocoa beans in meshed bowl (Initial condition)

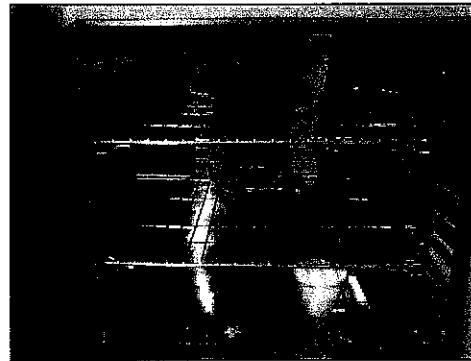

Meshed bowl in the oven with cocoa beans

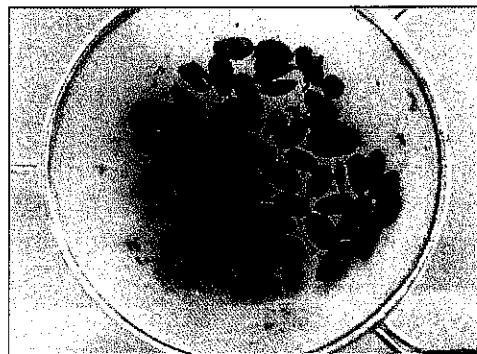

Dried cocoa beans