

**Design of Contactor Vessel for CO₂ absorption from Natural Gas at Reserves
using FLUENT**

by

Norkaramina Binti Ab Ilah

Dissertation submitted in partial fulfillment of
the requirements for the
Bachelor of Engineering (Hons)
(Chemical Engineering)

JUNE 2010

University Teknologi PETRONAS

Bandar Seri Iskandar

31750 Tronoh

Perak Darul Ridzuan

CERTIFICATION OF APPROVAL

**Design of Contactor Vessel for CO₂ absorption from Natural Gas at Reserves using
FLUENT**

by

Norkaramina Binti Ab Ilah

A project dissertation submitted to the

Chemical Engineering Programme

Universiti Teknologi PETRONAS

in partial fulfillment of the requirement for the

BACHELOR OF ENGINEERING (Hons)

(CHEMICAL ENGINEERING)

Approved by,

(Dr. Murni Melati Binti Ahmad)

UNIVERSITI TEKNOLOGI PETRONAS

TRONOH, PERAK

June 2010

CERTIFICATION OF ORIGINILITY

This is to certify that I am responsible for the work submitted in this project, that the original work is my own except as specified in the references and acknowledgments, and that the original work contained herein have not been undertaken or done by unspecified sources or persons.

NORKARAMINA BINTI AB LLAH

ABSTRACT

Natural gas (NG) is the most important energy source in various sectors and industries not only for power generation, but also as a primary feedstock for chemicals, plastics and fertilizers. Due to high demand of natural gas as an energy source, the explorations of natural gas that contain more than 30 percent of CO₂ become necessary. As CO₂ has been the major global warming contributor to the earth which also degrades the quality of natural gas and causing corrosion in refinery, this project aims to propose a new absorption system that uses methyethanolamine (MEA) to pre-treat at the source and lower the CO₂ content before it enters the refinery. CO₂ is treated with MEA along the height of contactor vessel and the absorption rate is measured at temperature of 30°C with the pressure range from 1 to 80 atm. This new absorption system is developed to remove 6 to 10 percent of CO₂ from natural gas stream i.e. the CO₂ content is reduced to 20% before transporting the natural gas to the amine treating unit. The work investigates the effect of operation pressure and gas and solvent velocities on CO₂ concentration. The pressures used are 1, 10, 50 and 80atm and the velocity of gas are 6 and 28m/s with solvent superficial velocity of 0.016 and 0.055m/s. Studies shows that with the increase in operation pressure and solvent velocity directly increases the CO₂ removal efficiency. This work introduces a feasible integration of an absorption system to remove CO₂ at the NG reserves.

Keyword: computational fluid dynamic (CFD), reactive absorption, immobilized aminated resin, contactor design, CO₂ absorption

ACKNOWLEDGEMENT

Throughout the progress of my Final Year Project, I would like to acknowledge my family for always being there to provide moral support to me as well as my Final Year Project supervisor which is Dr. Murni Melati and Miss Athirah, Postgraduate student. During the progress of the FYP, Dr. Murni and Miss Athirah provided lots of feedback that is related to the project as well as provided their valuable experience on the subject. They also introduced to me the aspects needed to do my FYP and the methods which are to be used to analyze the project so that the needed result can be obtained. Besides that, Dr. Murni always encouraged to do the best and that the project can be solved by multiple methods and that it is important that we do not stray from the main topic and that it is better to provide more alternatives for the project so that with more choices, chances that a better alternative can be found.

TABLE OF CONTENT

ABSTRACT	i
ACKNOWLEDGEMENT	ii
CHAPTER 1	1
1.1. Natural Gas as Fuel	1
1.2. Natural Gas Global Demand	2
1.3. CO₂ Content in Natural Gas	2
1.4. Techniques for CO₂ absorption	4
1.5. Problem Statement	5
1.6. Objective	6
1.7. Scope of Work	6
CHAPTER 2	8
2.1. Specially Design Solvent	8
2.2. Contactor Vessel Design	10
2.2.1. Bubble column	10
2.2.2. Spray column	11
2.3. Column Internals	11
2.3.1. Gas Chamber	12
2.3.2. Gas Distributor	12
2.3.3. Deflecting Plates	14
2.4. Computational Fluid Dynamics	15
2.4.1. Mathematical modeling	15
2.5. Factorial Method of Cost Estimation	17
CHAPTER 3	18
3.1. Research Methodology	18
3.2. Gantt Chart	22
3.3. Software Required	27
CHAPTER 4	28
4.1. 3D Gambit Drawing	28
4.2. Effects of operating pressure	29
4.3. Effects of superficial natural gas and specially designed velocity	31

4.4. Temperature Profile	35
4.5. Distribution of CO₂ concentration	36
4.6. Contactor vessel cost estimation	39
CHAPTER 5	40
5.1. Conclusion	40
5.2. Recommendations	41
REFERENCES	42
APPENDIX	46

LIST OF FIGURES

Figure 1: Natural Gas used by Electric Power Sector, Industrial Sector, Commercial Sector, Residential Sector, and Vehicle Fuel	1
Figure 2: Natural Gas demand outlook by residential and commercial, industry, power generation and others sector in Europe.	2
Figure 3: The average of CO ₂ content in Peninsular Malaysia and Sarawak	3
Figure 4: Schematic diagram of gas chamber and bubble column [15].....	12
Figure 5: Eight types of gas distributor configuration [18].....	13
Figure 6: Deflecting system [19]	15
Figure 7: Process Flowchart for FYP execution	20
Figure 8: Dimension and geometry of contactor vessel.....	21
Figure 9: Gambit 3D of Absorption Column	29
Figure 10: Effects of Operating Pressure at constant superficial velocity of specially designed solvent and natural gas.....	30
Figure 11: Influence of superficial velocity of specially designed solvent at 0.016m/s and natural gas of 6m/s	32
Figure 12: Influence of superficial velocity of specially designed solvent at 0.055m/s and natural gas of 6m/s	32
Figure 13: Influence of superficial velocity of specially designed solvent at 0.016m/s and natural gas of 28m/s	33
Figure 14: Influence of superficial velocity of specially designed solvent at 0.055m/s and natural gas of 28m/s	33
Figure 15: Total pressure drop with respect to column height at different natural gas superficial velocity of (a) 6 m/s, and (b) 28 m/s	34
Figure 16: Temperature profile calculate by the model	36
Figure 17: CO ₂ concentration in absorption system (a) 80 atm and (b) 10 atm.....	38

LIST OF TABLES

Table 1: Typical Composition of Natural Gas	4
Table 2: Physical and chemical properties of aqueous MEA solutions at temperature of 25°C, a total pressure of 1 atm [12]	9
Table 3: Summary of previous geometrical bubble column	10
Table 4: Specification of spray nozzles [16].....	11
Table 5: Estimation of bubble diameter and interfacial area for different types of sparger configuration [18].....	14
Table 6: Gantt chart for FYP 1.....	24
Table 7: Gantt chart for FYP 2.....	25
Table 8: Parameters used in the simulations	29
Table 9: Pressure drop correlation at different natural gas superficial velocity	35

CHAPTER 1

INTRODUCTION

1.1. Natural Gas as Fuel

Natural gas has been use as fuel to keep warm, to provide electricity to light their homes and to run industries, and to move about using cars, buses, boats, trains and airplanes for many centuries. According to the Energy Information Administration (EIA) 23 percent of energy consumes in United States is from natural gas [1]. Natural gas is used for residential, commercial, industrial, electrical power, commercial as well as vehicle fuel. The chart below shows the proportion of natural gas per sector. The use of natural gas in commercial sector is similarly to residential sector including public and private enterprises. It is mainly used in space heating, water heating and cooling, and cooking facilities. The transportation sector has taking the loop into natural gas vehicle (NGV) which is cheaper than petroleum due to increase of petroleum price crisis in 2008. The beneficial values of natural gas used in vehicles are based on fuel cost savings, maintenance (oil change intervals), and extremely smooth engine performance [2]. Hence, natural gas has become the main fuel consumption to its consumers.

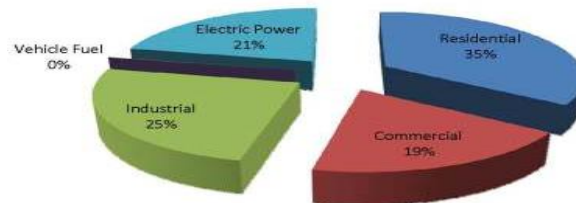

Figure 1: Natural Gas used by Electric Power Sector, Industrial Sector, Commercial Sector, Residential Sector, and Vehicle Fuel

1.2. Natural Gas Global Demand

According to the IEO2009, International Energy Outlook reference case, the total natural gas consumption is increases by an average of 1.6 percent per year from 104 trillion cubic feet in 2006 to 153 trillion cubic feet in 2030 [3].

Figure 2 is the natural gas demand outlook that being predicted by the Eurogas. These predictions are reviewed from the oil and gas prices remaining at high level, increased environmental awareness in politics and among consumers. The choice of using natural gas as fuel is increasing and has been an important role in sustains energy [4].

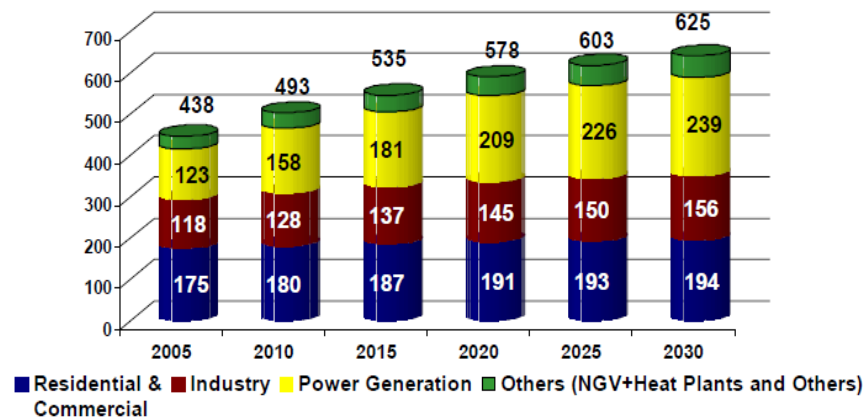

Figure 2: Natural Gas demand outlook by residential and commercial, industry, power generation and others sector in Europe.

In Malaysia, PETRONAS estimates the demand for natural gas in Peninsular Malaysia has increased by 97 percent since 1997 [5] which has put strain on supply facilities. The offshore production facilities and the Peninsular Gas Utilisation (PGU) system are running at full capacity to meet increasing demand. The demand may outstrip to 4900 MMSCFD per day by 2027. Meanwhile, gas supply from offshore Terengganu can only be sustained at 2000 MMSCFD.

1.3. CO₂ Content in Natural Gas

It is being reported that most of the natural gas reserves in Terengganu offshore contains excessive amount of CO₂ up to 87 percent. Currently, PETRONAS encounter problems in reducing the amount of CO₂ as their amine

technology can only cater up to 20 percent of CO₂ content which is more suitable for onshore plant rather than offshore platform. According to the report from PETRONAS, the individual natural gas reserves CO₂ content ranges from 28 percent to 87 percent [6]. From the exploration report, there is average of CO₂ content at Peninsular and Sarawak at 46 percent and 72 percent, respectively.

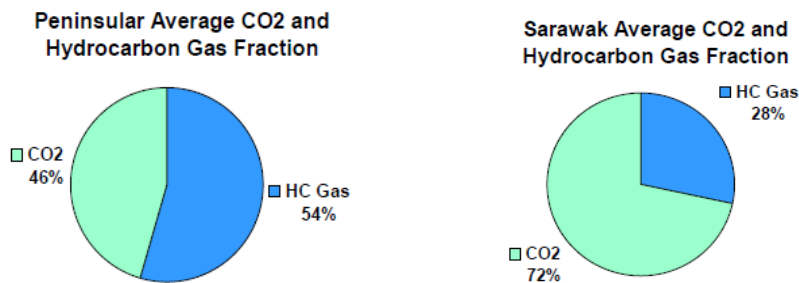

Figure 3: The average of CO₂ content in Peninsular Malaysia and Sarawak

Natural gas is a naturally gas mixture, containing mainly of methane. The quality of natural gas can be downgraded by the high content of CO₂. Significantly, the present of CO₂ will route to corrosion problem, reducing natural gas heating values and in advantage of enhancing the oil recovery. Table 1 outlines the typical components of natural gas and the typical ranges for each of the components [7]. The compositions of natural gas may vary at every location and region and the system average heating values depend on the mix of gas supplies and therefore can vary from the typical value listed below in Table 1. With this amount of CO₂, it is sufficient to be treated through amine absorption system.

Researchers are dealing with complication in reducing the high content of CO₂ before transporting the natural gas to onshore platform as per requirement in the onshore amine treating system. Thus, an effective absorption system located at the offshore platform is required to sustain the market demand and meet the standard composition of CO₂ content in natural gas. This paper will represents the new contactor vessel that can operates at pressure upto 80 atm and reduce the CO₂ amount to 20 percent.

Table 1: Typical Composition of Natural Gas

Composition in Natural Gas	Mole Percentage (%)
Methane	70 – 90
Ethane	0 – 20
Propane	0 – 20
Butane	0 – 20
Carbon dioxide	0 – 8
Oxygen	0 – 0.2
Nitrogen	0 – 5
Hydrogen sulphide	0 – 5

1.4. Techniques for CO₂ absorption

Researchers has developed various types of technologies for CO₂ absorption for petrochemical and oil and gas industries such as gas absorption, cryogenic separation, membrane separation and adsorption system with the presence of alkanolamines as the physical solvent to absorb CO₂. Many types of gas absorption from time to time to enhance the recovery of natural gas including packed bed, fluidized bed, different types of sparger or gas distributor designs, enhancement of the structured packing designs and its catalysts and multiple types of trays. In contrast to absorption, an improved pressure swing adsorption and temperature swing adsorption is providing CO₂ absorption from natural gas by scrubbing the gas through amine solvent. The use of membrane to absorb CO₂ has also been applied and limited by current available membranes. Yet it is not applicable for high pressure system as membrane is easy to tear. The disadvantage of cryogenic processes as it is not reliable for CO₂ capture because of the physical and chemical properties. To conclude the techniques for absorbing CO₂, absorption-based is the best option for CO₂ absorption at the present time [8].

Other than influences from the geometry and the internals of the column as well as the type of physical solvents used, the operating parameters shall be taken into account. The gas flow rate and liquid flow rate distribution and its direction of flow have given an impact to the equipment design and mass transfer. In designing of chemical process equipment the design parameters which are required for the system are mixing time, heat and mass transfer coefficient, drag coefficient, and multiparticle homogeneous or heterogeneous dispersion. Conversely, it depends on the model used and CFD solver.

One of the most commercial physical solvent uses in CO₂ absorption is alkanolamines. Researchers are developing a cost-effective and energy efficient of CO₂ absorption system by improving the performances of amine solutions. The most common amine solution being used for the processes are monoethanolamine (MEA), diethanolamine (DEA), diisopropanolamine (DIPA), methyldiethanolamine (MDEA), and 2-amino-2methyl-1-propanol (AMP). In consequences of using these alkanolamines, plants experience operating difficulties in foaming, failure to meet gas specification, high solvent losses, corrosion, fouling of equipment, and contamination of the amine solutions [9]. Additionally, the higher content of amine in the solution requires high energy requirement for solvent regeneration.

1.5.Problem Statement

With the current amine treating technology, the ratio of capturing amine solution is 0 to 0.5 mole CO₂/mole amine [10]. The amine solution can capture CO₂ content up to 20 mole percent where as the natural gas in Malaysia contains amount of above 30 mole percent of CO₂. This paper represents the investigation on the absorption of CO₂ from high CO₂ content hydrocarbon containing streams using methyethanolamine (MEA) in a contactor vessel. Modification to the internal contactors and the geometry of contactor vessel is been made to maximize the caption of CO₂ content. The analysis of mass transfer of CO₂ through MEA in a reactive absorption process is simulate to captures the maximize amount of CO₂. The reaction occurs on the surface of solid, thus,

modification shall be made to avoid disturbance to the mass transfer process at the best operating parameters. Hence to complement the existing amine system that removes CO₂ at refineries, an offshore unit is proposed to be installed at natural gas reserves to reduce CO₂ content to 20 percent, the feasible concentration to the existing amine system. The system is chosen to be located at the gas reserves to complement the limitation of the existing treatment unit at refinery and to reduce additional cost of pumping large amount of CO₂ content in natural gas streams as CO₂ gas dominates the composition of natural gas. To propose such unit, a study on mass transfer is required using FLUENT, a computational approach. This absorption unit uses MEA to capture CO₂.

1.6. Objective

- a. To design a contactor vessel for CO₂ to be installed at natural gas reserves to reduce CO₂ content from 70 percent to 20 percent using a MEA.
- b. To study the behavior of mass transfer via simulation approach in FLUENT.
- c. To identify the best operating parameters for the contactor vessel.
- d. To perform cost evaluation for the contactor vessel.

1.7. Scope of Work

The high pressure of CO₂ from the natural gas reserves is investigated to maintain the quality of the product and reduce the amount of CO₂ content from 70 to 20 percent. A new design of contactor vessel is evaluated at pressure range from 1 to 80 atm at temperature of 30°C. Different type of geometries and internals of contactor vessel is assessed to increase the interfacial area of gas and liquid. The types of internals of contactor vessel are gas spargers and baffles. The behaviors of the molecules are observed along the height of the contactor vessel using computational approach. The design is to improve the effectiveness of the mass transfer and the system. The composition of natural gas that will be evaluated is 30:70 of methane and carbon dioxide, respectively. There are several operating parameters which will be varied such as the gas flow rate, liquid flow rate, and natural gas pressure. The best operating parameter is identified to

maximize the amount of CO₂ captures. The configuration of the contactor vessel will be further improved from the estimation of gas holdup, liquid holdup, rate of diffusion of CO₂, formation of solid suspensions and contacting time of solvent and CO₂ by FLUENT. The cost of constructing the contactor vessel and its material is estimated.

CHAPTER 2

LITERATURE REVIEW

2.1. Specially Design Solvent

The most wide solvent use in CO₂ absorption is alkanolamine solvent. Researches invent a new specially design solvent where the aminated resin have a chemical reaction during the process. The advantageous of using the aminated resin as there are the combination of physical solvent of the tertiary amines with the high absorption rates achievable with primary and secondary amine which are methyldiethanolamine (MEA) and diethanolamine (DEA) [11]. These aminated resins enhance the mass transfer of the gas phase and liquid phase. The absorption of CO₂ is by chemical and physical reaction which leaving the column in the liquid stream shall be removed in the desorption contactor. The diameter of the aminated resin is in a range of 0.5 mm to 1mm and has a density of 1092 kg/m³ [11].

With the different concentration of MEA in the physical solvent, it affects the amount of CO₂ being absorbed through the resin. The result of the MEA concentration yield to increase in CO₂ absorption rate and decrease in liquid phase transfer efficiency. Since, 30 wt% of MEA have higher viscosity causes the solution to flow slowly which offers longer residence time in the column at constant liquid flow rate. The physical and chemical properties of MEA solution being used in the previous paper is tabulated as below [12].

This specially design solvent are tested at different flow configurations which are vertical upward (VU), vertical downward (VD) and horizontal (H) where as the natural gas shall be feed at the bottom of the contactor vessel. These flow configurations will affect the pressure drop in the contactor vessel and interfacial area between the gas phase and liquid phase.

Table 2: Physical and chemical properties of aqueous MEA solutions at temperature of 25°C, a total pressure of 1 atm [12]

Property	Unit	15 wt% MEA solution	30 wt% MEA solution
Density	kg/m ³	1003	1010
Viscosity	mPa.s	1.45	2.41
Surface tension	mN/m	59.1	55.1
Physical solubility of CO ₂	kg/m ³	0.119	-
Overall solubility of CO ₂	kg/m ³	64.9	127.6
Diffusivity of CO ₂	m ² /s	1.42 x 10 ⁻⁹	-
Reaction rate constant	m ³ /mol-MEA.s	5.40	-

Larger pressure drop in a contactor vessel disintegrate the energy use for the system and also affects the efficiency of the contactor vessel. It is also influence by the concentration of the fluid, liquid and gas flow rates and internal geometry. Flow configurations from horizontal and vertical downward gives lesser amount of pressure drop due to gravitational effects. This is because flow configurations from vertical downward does not induce much pressure drop due to it positive gravitational effect still there is slightly pressure drop for the horizontal flow because gravitational effects make more difficult the establishment of a dispersed spray [13].

The interfacial area between the gas phase and the liquid phase is the most important factor in designing the absorption system as the diffusivity of these phases are depending on the mass transfer coefficient. Among all the flow configurations, vertical downward flow gives higher interfacial area than horizontal flow due to its positive gravitational effects. The horizontal flow constitutes a brake flow [13]. In vertical upward flow, it results in higher interfacial area as the liquid phase because of overcome the gravitational force which increase the agitation in the contactor. The interfacial area is influence by the superficial velocity of liquid and gas. The increase of superficial velocity will increase the liquid velocity, pressure drop and interfacial area. In spite of this, the

superficial velocity of liquid does not give much effect to the mass transfer. The vertical downward configuration is the best flow configuration as it gives lower pressure drop; lesser energy consumption and good mass transfer coefficient which also depending on the geometrical design of contactor vessel.

2.2. Contactor Vessel Design

The contactor vessel efficiency of gas absorption through specially design solvent is strongly depending on the geometrical and hydrodynamic design of the gas-liquid contactor other than the type of solvent being used.

2.2.1. Bubble column

Bubble column reactor is the most significant gas-liquid contactor that being used for CO₂ absorption [14]. Bubble column is a choice of a gas-liquid contactor because of its simplicity in terms of construction and operation. It provides best degree of liquid phase mixing, heat and mass transfer between the fluids and column wall that can be observed from FLUENT. Bubble column consists of a vertical cylindrical contactor with height-to-diameter ratio in the range of 3 to 10 [15]. The performance of the bubble column is determine by many parameters such as the diameter of bubble column, superficial gas velocity, gas distributor design and the height of the liquid phase in the column. Natural gas shall be introduced through a sparger at the bottom of the contactor vessel through gas distributor. There are several types of sparger that being put to practice in gas-liquid absorption which include sieve plate, ring, spider, radial sparger, ejector and injector. From the previous papers, various geometrical of bubble column being tested to improve the efficiency of an absorption system as tabulated below.

Table 3: Summary of previous geometrical bubble column

Author	Height (m)	Diameter (m)
Krishna and Van Baten	3.0	0.380
Pfleger and Becker	2.6	0.288

Kulkarni et al.	1.0	0.150
Kuntz and Aroonwilas	0.55	0.100

2.2.2. Spray column

Spray column is one of the gas-liquid contactor that has been used for CO₂ absorption system other than bubble column. Previous literature describes the comparison on various types of nozzles and their performance using MEA solution. In evaluating the effectiveness and the capacity of nozzles, it will be operated at different range of liquid flow rates and pressures so the nozzles will be fully utilized. The specifications of spray nozzles in the previous paper are tabulated in Table 4. The interfacial area of the solvent will be increases with the increase of the nozzle size as it increases the amount of liquids droplets for mass transfer at optimal operating condition. As the liquid flow rate increases, it produces smaller liquid droplets that results in higher mass transfer coefficient [16]. The tower pressure of spray column is held between 70 atm upto 73 atm with ten theoretical trays [17].

Table 4: Specification of spray nozzles [16]

Types of spray nozzle	P-20	P-28	P-40
Orifice diameter (mm)	0.508	0.711	1.02
Spray angle (degree)	90	90	90
Liquid flow rate at 1 bar (L/min)	0.153	0.296	0.638
Liquid flow rate at 5 bar (L/min)	0.341	0.662	1.43

2.3.Column Internals

The most important characteristic in the design and operation of a bubble column is the gas and liquid deflecting system. These deflecting system and gas distribution controls the bubble size distribution and the hold-up profile which manipulate the flow pattern, effective interfacial area, rates of mass transfer, heat

transfer and mixing. All this behavior behaviors cause an impact to the residence time distribution, and the contactor vessel performance

2.3.1. Gas Chamber

Consecutively, to attain a uniform gas distribution along the contactor it is crucial to understand the flow pattern of the upstream and downstream on the gas distributor sites to avoid larger pressure drop as this is strongly depends on the gas chamber design. Gas chamber can be position at two different locations which are 0.2 and 2.5 [15] below the bubble column as per Figure 4. In order to design the best gas chamber shall include the inlet nozzle position and its size. At these different location of gas chamber shall affects the velocity distribution of gas through the gas distributor.

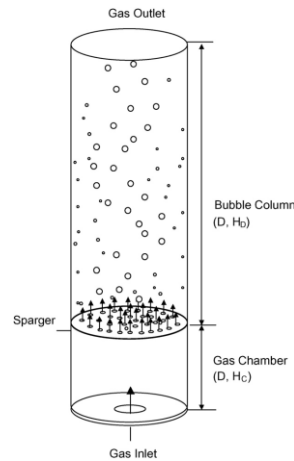

Figure 4: Schematic diagram of gas chamber and bubble column [15]

2.3.2. Gas Distributor

Previous paper represents the effects of eight types of gas distributor configuration towards gas hold-up distribution, the liquid velocities within the bubble column, flow patterns, mixing time with turbulence and bubble size. Figure 4 signify the eight different multi-pipe gas distributors. Gas distributor A has one gas sparger pipe at the center of a circular plate. In the case of gas distributor B, it consist of two symmetrical gas sparger pipe with the ration of the ring to bubble column diameter is 0.5. Three gas sparging

pipe distributed in a ring with ring to bubble column diameter ratio of 0.5. For gas distributor E and F, both have four sparger in a ring with ring to bubble column diameter of 0.5 and 0.3 respectively. This gas sparger pipe is adjacently 90° from the center of the bubble column. The gas distributor G has the same gas distributor configuration of gas distributor E with an addition of one centered gas distributor pipe allocated on the circular plate. Gas distributor H is a sintered plate [18].

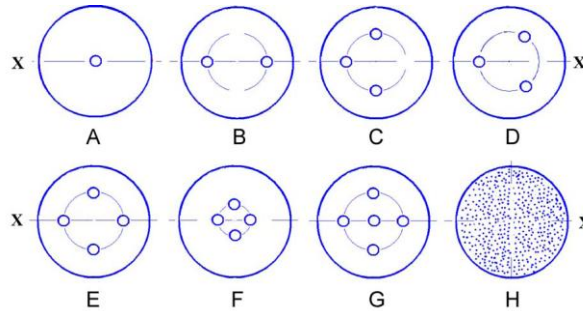

Figure 5: Eight types of gas distributor configuration [18]

The flow pattern in the bubble column for all types of gas distributors is heterogeneous. Gas hold-up effects directly to the interfacial mass. Single pipe gas sparger gives the poorest gas phase dispersion as it creates large circulation vortices causes poor entrainment of the bubble around vortices. The simulation shows that the increase of gas sparger pipe will increase the overall gas holdup where the local gas holdup and liquid velocities are narrowed with respect to the gas sparger pipes. The change are not noticeable with the number of gas sparger pipe more than three However, it also depends on the ring to bubble column diameter ratio as larger ring has achieve higher gas dispersion than smaller ring. There is an oscillation shows the influence of height-to-diameter ratio of less than one which shows the instability of the system. The average bubble diameter and interfacial area for different gas distributors are estimated and tabulated as in Table 5. The use of gas distributor D is the best sparger to use as it promotes higher interfacial area through the overall gas holdup which is beneficial to the mass transfer between phases. Besides that, the configuration of the gas distributor shall be optimizing as the liquid flow regime and bubble dispersion also affects the

mixing. Smaller ring to diameter ratio reduce the mixing time, bubble size and increase the liquid flow in the bubble column.

Table 5: Estimation of bubble diameter and interfacial area for different types of sparger configuration [18]

Gas Distributor	A	B	C	D	E	F	G	H
Bubble diameter (mm)	5.36	5.83	6.33	5.7	6.34	5.93	6.17	6.41
Interfacial Area (m^{-1})	159.0	198.6	161.4	224.4	206.4	190.2	207.0	222.0

2.3.3. Deflecting Plates

The gas distributor shall be equipped with deflecting system which is baffles. This deflecting system will circulate the gaseous or liquid flowing through the contactor vessel to direct the liquid phase and improves the outflow and mass transfer between both gas and liquid phase. With the deflecting, it will overcome the gas or droplets being carried away by the liquid through impact effect. Hence, there will be greater contacts for mass transfer for both phases. Figure 5 shows the contactor consist a liquid pathway, SD and gas pathway, SAA. The The deflecting plates (1,2,3,4,5) are located on the gas distributor is tilted from vertical. These baffles have a main bottom part and a shorter bent top to canalize and distribute the gas phase over the whole pathway section available to gas. The deflecting system shall be implement at least one at the gas distributor and add it when necessary to optimize the rate of CO₂ absorption [19].

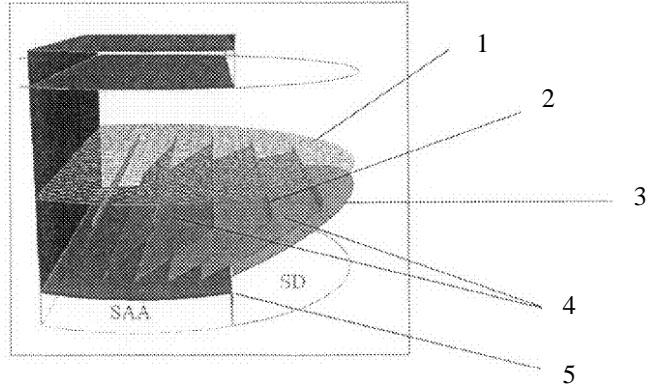

Figure 6: Deflecting system [19]

2.4. Computational Fluid Dynamics

In examining the chemical absorption in a contactor vessel with the sets of operating parameters i.e. gas and liquid flow rate, wide range of pressure between 1 atm upto 80 atm; geometry of contactor vessel and gas distributors i.e. column diameter, diameter of holes; and the system properties are essential in determining the fluid flow patterns, residence time distribution and mass transfer rates. Assumptions are made for simplicity of the model is express in the previous papers. The main assumptions are considering the equilibrium for both liquid and gas phase at each tray and neglecting the mixing of fluids of the tray. It also assumed that the flow is turbulent and highly mixed. The turbulent Schmidt can be assumed equal to one. Therefore, the turbulent viscosity is equal to the product of density and eddy diffusivity [20]. In acquiring the best mathematical modeling, equitable boundary conditions are being implemented for both gas chamber and bubble column as been specified as follows. The Eulerian model is used as it is suitable for 3 phases flow designs.

2.4.1. Mathematical modeling

The inlet nozzle of the gas chamber can be allocated at the bottom or on the side. The location and the size of the nozzle can be varied over 0.002 m and 0.004 m [15]. The mass transfer of natural gas through reactive specially

designed solution involves three sequences of steps which are dissolution, diffusion and reaction. The following boundary condition shall be use:

- I. The inlet velocity is specified
- II. At the top of the gas distributor is considered active gas flow
- III. Standard wall functions is employed for the flow near the wall
- IV. The pressure profile from gas chamber is employed on the gas distributor
- V. No slip boundary condition at the along the wall and gas distributors holes
- VI. The gas absorption chemical reaction occurs at the liquid phase

The correlation of CO₂ diffusivity into aqueous MEA can be determined using the equation below [22]:

$$D_{CO_2,L} = D_{N_2O,L} \left(\frac{D_{CO_2}}{D_{N_2O}} \right)_w \quad (1)$$

The diffusivity of CO₂ and N₂O in pure water can be determine using the correlation follows [23]

$$D_{CO_2} = 2.35 \times 10^{-6} \exp\left(\frac{-2119}{T}\right) \quad (2)$$

$$D_{N_2O} = 5.07 \times 10^{-6} \exp\left(\frac{-2371}{T}\right) \quad (3)$$

The diffusivity of N₂O in MEA can be determine using the correlation follows [24]

$$D_{N_2O,L} = \left(5.07 + 0.865 X_{MEA} + 0.278 X_{MEA}^2 \right) \times \exp\left(\frac{-2371.0 - 93.4 X_{MEA}}{T}\right) \times 10^{-6} \quad (4)$$

The diffusivity of CO₂ into MEA is assumed constant along the system. The boundary conditions are specified to simplify the system using correlation. In

order to simplify the equation, the fluids creates turbulence and well-mixed along the contactor height without any pressure drop. The boundary conditions for the momentum transfer of liquid phase are set as follows:

$$x = 0, \quad u_L = u_{L,0}, \quad v_L = 0 \quad (5)$$

$$x = d, \quad \frac{\delta u_d}{\delta x} = 0, \quad \frac{\delta v_d}{\delta x} = 0 \quad (6)$$

$$y = 0, \quad \frac{\delta u_L}{\delta y} = 0, \quad v_L = 0 \quad (7)$$

$$y = y_{wall}(x), \quad u_L = 0, \quad v_L = 0 \quad (8)$$

The equations and boundary conditions that have been modeled are extracted from previous work that design and simulate the CO₂ absorption system [20].

2.5. Factorial Method of Cost Estimation

The factorial method of cost estimation is based on Lang factors [21]. The fixed capital cost is given as a function of total purchase equipment which can be derived as:

$$C_f = f_L C_e \quad (9)$$

where C_f = fixed capital cost

C_e = total delivery cost of all the major equipment items

f_L = the “Lang factor”, Lang factor is 3.6 for a mixed fluids-solids processing plant

The cost data given based on the vertical height has been compiled from numerous resources which can be used for equipment cost estimations as per Attachment A. The base date is mid of 2004 and the accuracy of the estimation within ± 25 percent [21].

The cost of purchasing vertical vessel can be defined in Equation 10:

$$\text{Purchased cost} = (\text{bare cost from Attachment A}) \times \text{Material factor} \times \text{Pressure factor} \quad (10)$$

CHAPTER 3

METHODOLOGY

3.1. Research Methodology

The flowchart in Figure 7 represents the execution phases for final year project (FYP) research. At the preliminary research stage, all previous papers regarding the CO₂ absorption, mathematical modeling and boundary conditions for CO₂ chemical absorption process that can be use in CFD, and the types and geometrical of contactor vessel being used for CO₂ absorption. Most of the previous paper uses the packed column, spray column, bubble column and sieve plates column for the absorption of CO₂. In this paper, the combination of bubble column reactor and spray column is use for the design of the new contactor vessel. The bubble column reactor shall include a gas chamber as describe in Chapter 2.3.1. The MEA shall flow through the specified nozzle size in Table 4 to evaluate and attain maximum absorption of CO₂. In order to make the system more efficient, various area of improvement need to be made as absorption rate of CO₂ is influence by many factors; the geometry of contactor vessel, internals of column and deflecting system. Likewise, the best operating parameters and the direction of flows for the system shall affect the absorption rate which will be focusing on the flow rates of gas and solvent as well as the operating pressure of the system.

The natural gas shall be feed at the bottom of gas chamber through inlet of gas chamber at wide range of flow rates. Subsequently, the height-to-diameter ratio shall be manipulated based on Table 3 to determine the best geometrical design of the contactor. Then, a gas distributor will be place in the contactor to monitor the flow pattern of fluids. Deflecting plates are located on the sites of gas distributor to increase the contact between both gas and liquid phase. All the parameters shall be simulate to evaluate the result and graph trend presents

precise results before proceed to the other parameters. Cost is estimated for the final design of the contactor vessel that is feasible to be use for industrial scale.

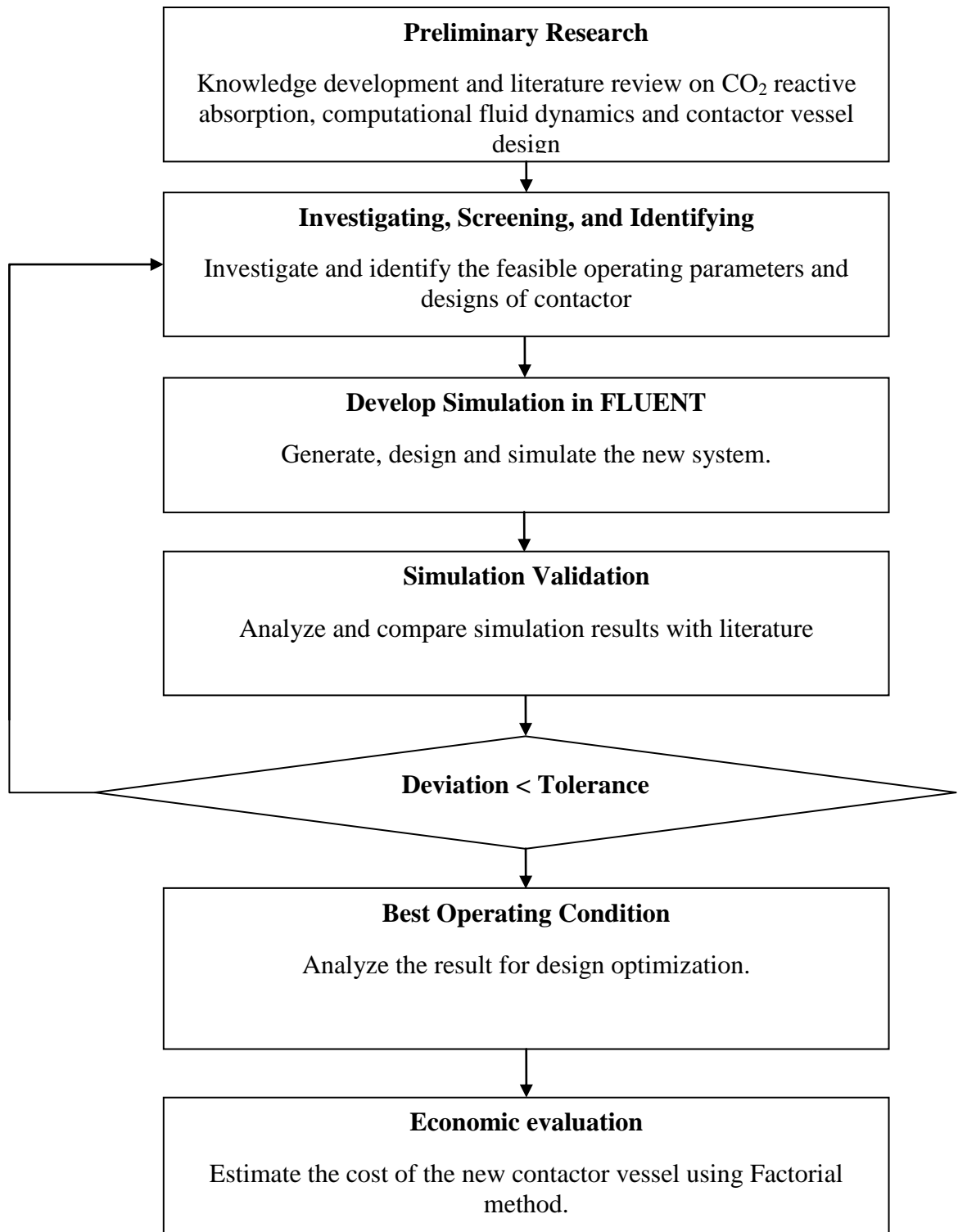

Figure 7: Process Flowchart for FYP execution

The details of the geometry of the column are based on the spouted – bed reactor with the dimension of 1.0 m of height and 0.15 m in diameter is illustrated in figure below. The scale of the dimension is in meter (m).

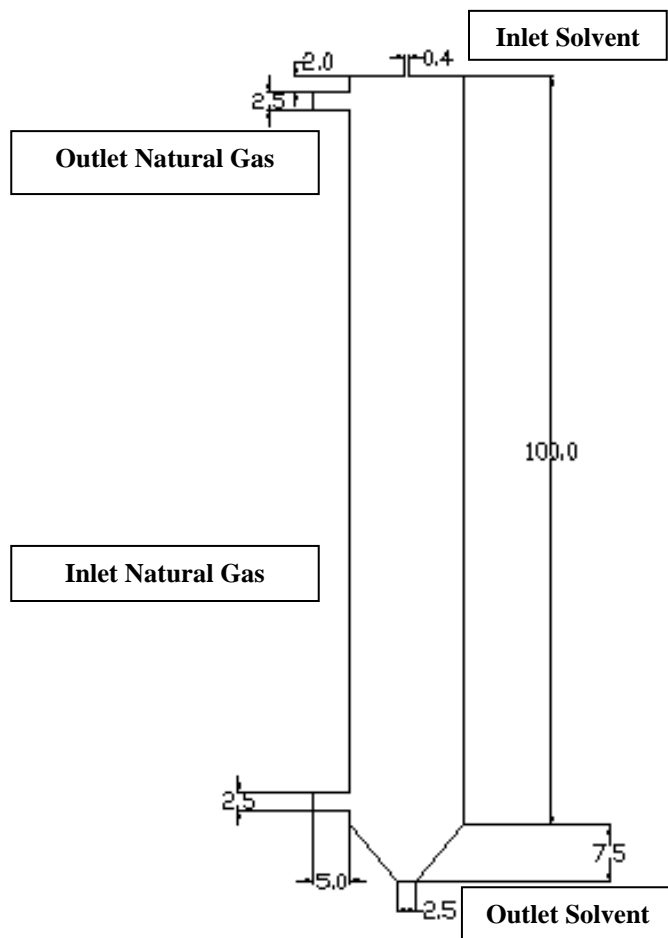

Figure 8: Dimension and geometry of contactor vessel

There are three factors that are evaluated in this paper which are natural gas operating pressure, superficial gas velocity and superficial liquid velocity. The system shall receive a pressure from the natural gas reserves at 1 to 80 atm at the superficial velocity of 6 to 28 m/s. The superficial specially designed solvent flow vertical downward at the velocity of 0.016 to 0.055 m/s.

3.2. Gantt Chart

Table 6 and Table 7 is the summarized of the final year project research course. These Gantt chart represents the timeline and the scope of work that shall be conducted throughout the research. It consists of three stages: (1) Preliminary research, (2) Replicate and (3) Reproduce. The research starts from gathering actual data and design that has been done by previous papers that are designing the CO₂ absorption system using the numerical and experimental work. The followings are the operating parameters and types of gas-liquid contactor that are suitable and affecting the absorption rate of CO₂.

1. The flow configuration of specially design solvent is in vertically downward direction flow through a nozzle size of 0.001m at height-to-diameter ratio of 6.67 of a contactor vessel. The suitable H/D ratio is in the range between 3 to 10 [15].
2. The natural gas is fed at the bottom of the gas chamber through a 0.025m nozzle.

The dimension and geometry of the column is explained in Table 3 which been designed using GAMBIT. The operating condition of solvent velocities is at 0.016 to 0.055m/s whereas the gas velocity is at 6 to 28m/s. In this work, the minimum and maximum values of these velocities are being considered at the pressure of 1, 10, 50, and 80atm. The superficial velocity is obtained from C. Sanchez simulation study.

All the parameters shall be evaluated to compare the results and graph trend obtained from the previous papers. Since, this case study operates at higher pressure, the trends and graph curves are to be compared with other previous paper that varies the operating pressures in order to achieve the desired CO₂ content at 20 percent. At all times, the lowest operating pressure for an absorption system is to be at 1 atm, pumping power is necessary to increase the pressure designed. Simulation that shows precise result can be use as a design for the new contactor vessel. All the parameters that affect the removal efficiency of

the contactor vessel are modified for design optimization and identify the best operating parameter with maximum CO₂ removal efficiency. Detailed on cost estimation is made once the final design of the contactor vessel is achieved.

Table 6: Gantt chart for FYP 1

No	Detail / Week	1	2	3	4	5	6	7	8	9	10	11	12	13	14
1	Submission of Form02														
2	Submission of Form01														
3	Literature Review: a) Contactor vessel design for gas-liquid process b) Mathematical modeling and boundary conditions for CFD c) Properties of Specially design solvent d) Internals of column that enhance the absorption rate														
4	Submission of Preliminary report														
5	Submission of Progress report 1														
6	Seminar 2														
7	Comprehend with CFD														
8	Submission of Dissertation report														
9	Oral presentation														

Table 7: Gantt chart for FYP 2

No	Details / Week	1	2	3	4	5	6	7	8	9	10	11	12	13	14	18	20
1	Literature Review: a) Contactor vessel design for gas-liquid-solid process b) Mathematical modeling and boundary conditions for CFD c) Equations to estimate the cost of contactor vessel																
2	Submission of Progress report 1																
3	Simulation of variation on liquid flow rate (and gas flow rate at the pressure of 1atm, 10 atm, 50 atm and 80 atm and validate the result.																
4	Two type of gas distributor that offers higher interfacial area																

	shall be simulate for the system.																	
5	Model the best gas distributor with deflecting system.																	
6	Submission of Progress report 2 and Poster presentation																	
7	Submission of Final report (softbound)																	
8	Oral Presentation																	
9	Submission of Final report (hardbound)																	

3.3. Software Required

- a) FLUENT is computational fluid dynamic (CFD) software to study the dynamic flow which represents a system or device. It requires numbers of mathematical modeling; fluid flow physics and chemistry to generate the results of the fluid dynamics and related physical phenomena. CFD offers the simulation of flows on liquids and gases, heat and mass transfer, and chemical reaction through computer modeling which predicts the performance of the design [25].
- b) GAMBIT is preprocessing technologies interface for geometry creation and meshing for parametric studies. It can construct 3D that provides both the geometry import and tools function for creating designs. The meshing tools featured in GAMBIT assist of decomposing geometries for structured hex meshing or perform automated hex meshing with control clustering. Triangular surface meshes and tetrahedral volume meshes can be created within a single environment, along with pyramids and prisms for hybrid meshing [26].
- c) The cost evaluation for the new contactor vessel shall be calculated using Excel. Excel is an electronic spreadsheet program that used for manipulating data.

CHAPTER 4

RESULTS AND DISCUSSION

The geometrical contactor vessel significantly affects the absorption rate of specially design solvent. The most commonly height-to-diameter ratio is between 3 to 10 which is applicable to use the geometrical in Table 3. The specially design solvent is fed at the side of the top contactor through nozzle as the droplets is has much higher interfacial area to react with CO₂. The concentration of solvent that will be used in this case is 30 wt percent.

The natural gas will flow from the bottom of the gas chamber. The orifice diameter of natural gas inlet is 0.025 m. Different types of gas distributor are allocated at the roof of the gas chamber has the size of 0.002 in diameter of its nozzle. The outlet of the resins is located at the above of gas chamber whereas the natural gas outlet is located at the top side of the contactor.

The operating parameters and design shall be evaluated as per statement to compare the results from the previous papers. Precise results can proceed to other parameters. The final design of contactor vessel cost is estimate using the Lang factor.

4.1. 3D Gambit Drawing

Contactor vessel is drawn and meshed using GAMBIT with the interval size of 10 mm. The drawing generated is symmetrical in order for FLUENT to stipulated data for the simulation. The meshing of absorption column is shown Figure 9. The details of the parameters used for the simulation is tabuled in Table 8.

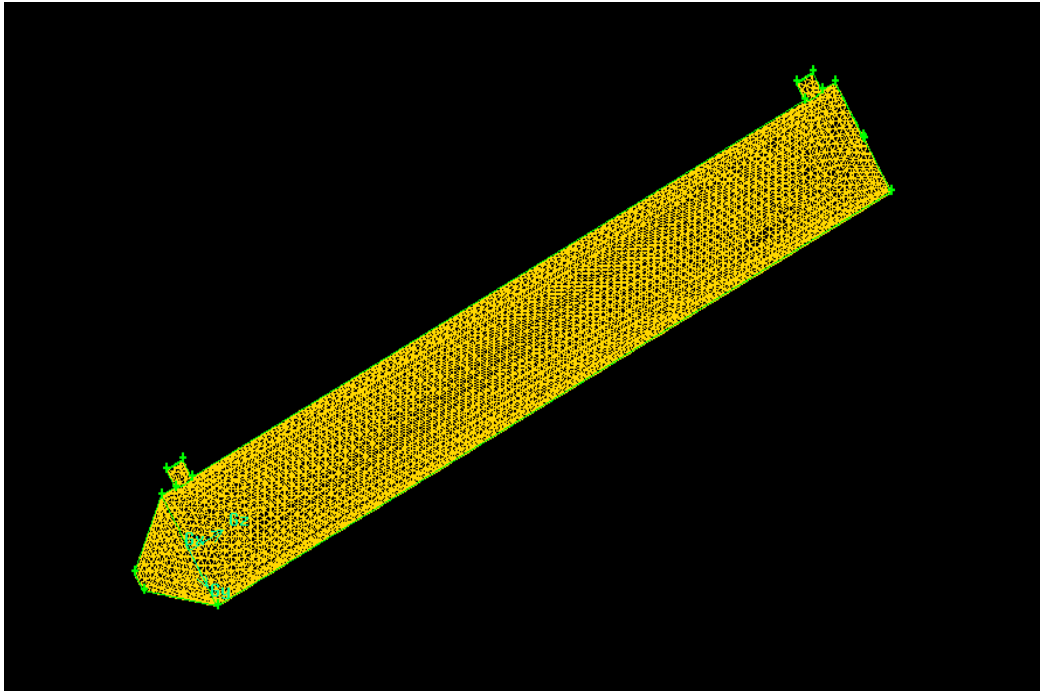

Figure 9: Gambit 3D of Absorption Column

Table 8: Parameters used in the simulations

Superficial of specially designed solvent	a) 0.016 b) 0.055	m/s
Superficial velocity of natural gas	a) 6 b) 28	m/s
Operating pressure	a) 1 b) 10 c) 50 d) 80	atm
Diffusivity of CO ₂ into MEA	5.699	m ² /s

4.2. Effects of operating pressure

The mass fraction of CO₂ is expected to decrease along the height of the column with the value of 0.2 at the outlet of natural gas. The mass transfer correlations that have been developed by Rocha et al. [30], Onda et al. [31], should not be a

general conclusion for each absorption system as the basis of the mass transfer correlation may varies in such as temperature of the system, specific flow correlations and specific design of contactors [28,29]. Subsequently, it leads to the performance of the absorption system.

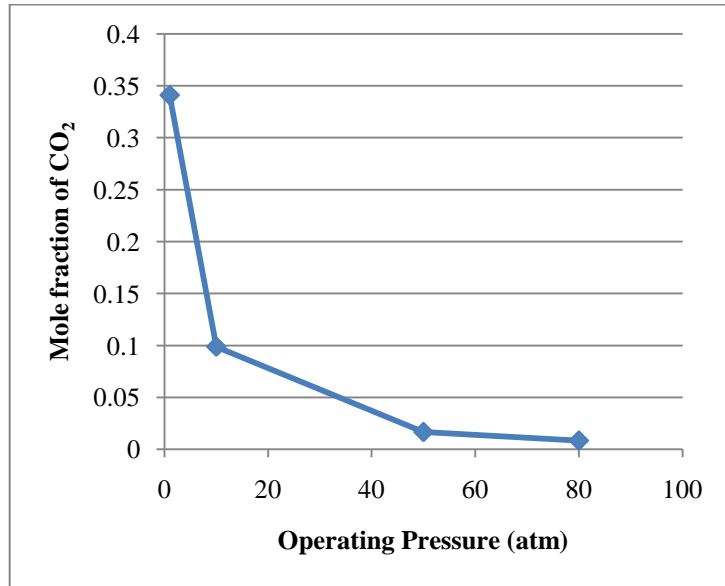

Figure 10: Effects of Operating Pressure at constant superficial velocity of specially designed solvent and natural gas ($U_s = 0.016\text{m/s}$; $U_G=6\text{m/s}$)

The effect of the operating pressure on CO₂ absorption rate with a specially designed velocity of 0.016 m/s and a natural gas flow of 6 m/s are kept constant. The temperature of natural gas and specially designed solvent flows at 303 K. Figure 10 shows the effect of the operation pressure on the CO₂ absorption performance. It can be seen that the removal efficiency increases with the increase of the operation pressure. At higher pressure, there is a greater mass transfer driving force. As the overall mass transfer coefficient increases with the pressure because decrease in liquid-film resistance that can be related with equation below.

$$\frac{1}{K_x a} = \frac{1}{k_x a} + \frac{1}{mk_y a} \quad (11)$$

where

$K_y a$ and $K_x a$ is the overall mass transfer coefficient liquid and gas

$1/k_y a$ and $m/k_x a$ is the resistances to mass transfer in the gas film and the liquid film

There shall be a constant trend and small effect of CO₂ absorption is observed when the operating pressure is further increased. It is said that the equilibrium between the liquid and gas phase is approached. This effect is caused by the limited absorption capacity with a fixed liquid and gas velocity.

4.3. Effects of superficial natural gas and specially designed velocity

Figure 11 and Figure 12 shows the influence of superficial specially designed velocities on the removal efficiency of CO₂ under the operation conditions of gas superficial velocity of 6m/s. An increase in the superficial liquid velocity yielded grater removal efficiency. At a higher superficial liquid velocity the liquid side mass transfer coefficient is much greater that is directly increases the absorption of CO₂. In the case of increase superficial liquid velocity, it provides higher gas – liquid interfacial area that is advantageous for CO₂ absorption as it has higher contacting surfaces for CO₂ chemical absorption because the system experienced increased of liquid hold-up. However, in higher superficial gas velocity shown in Figure 13 and Figure 14 decreases the contacting time of CO₂ and MEA that directly reduces the rate of CO₂ absorption. From the simulation that obtained, the effect of superficial specially solvent velocity at 0.016 m/s and 0.055 m/s gives an equal amount of CO₂ mole fraction at the outlet of the natural gas at 1 atm operation pressure. Initially, the CO₂ absorption rate increase until it reached a constant value of absorption rate, plateau. This phenomenon occurs because of the increase in velocity that reduce the resistance of stagnant – layer diffusion under laminar flow [27]. The mass transfer of CO₂ profile matches the experimental data prepared by Kuntz et al. [16].

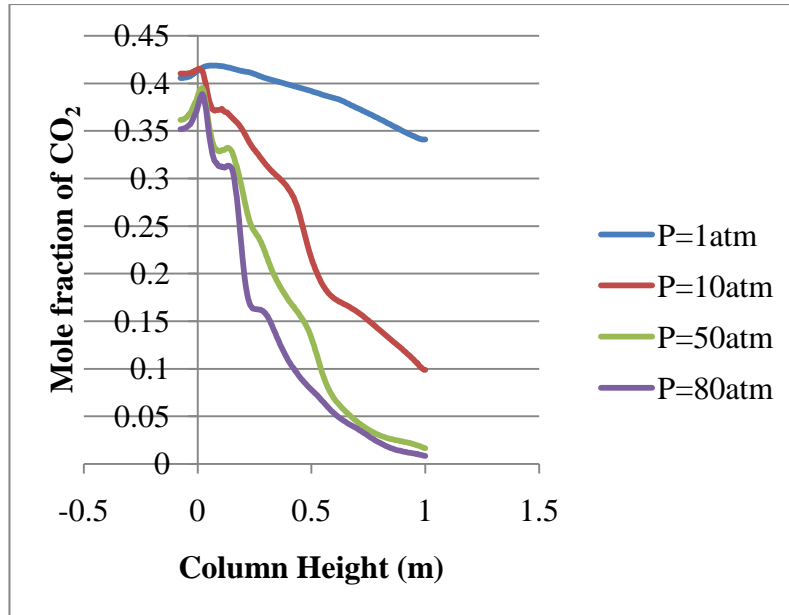

Figure 11: Influence of superficial velocity of specially designed solvent at 0.016m/s and natural gas of 6m/s

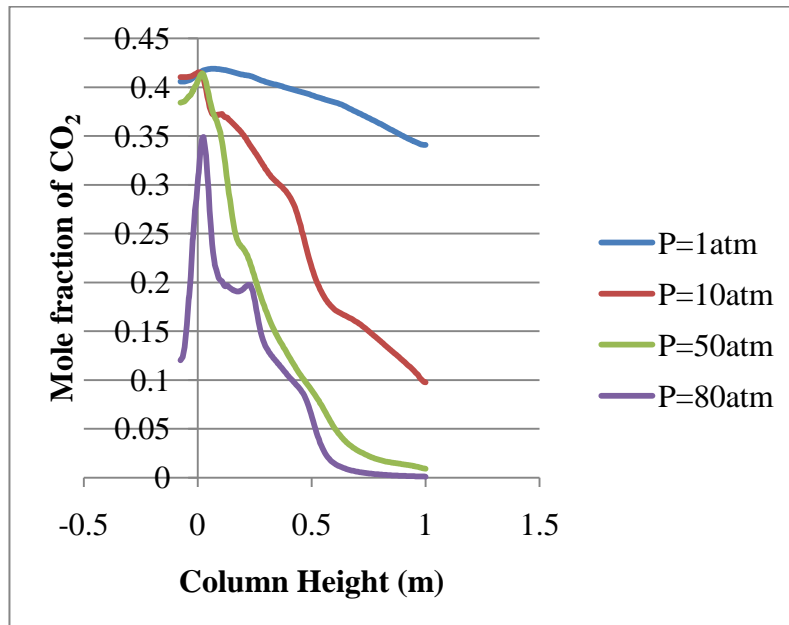

Figure 12: Influence of superficial velocity of specially designed solvent at 0.055m/s and natural gas of 6m/s

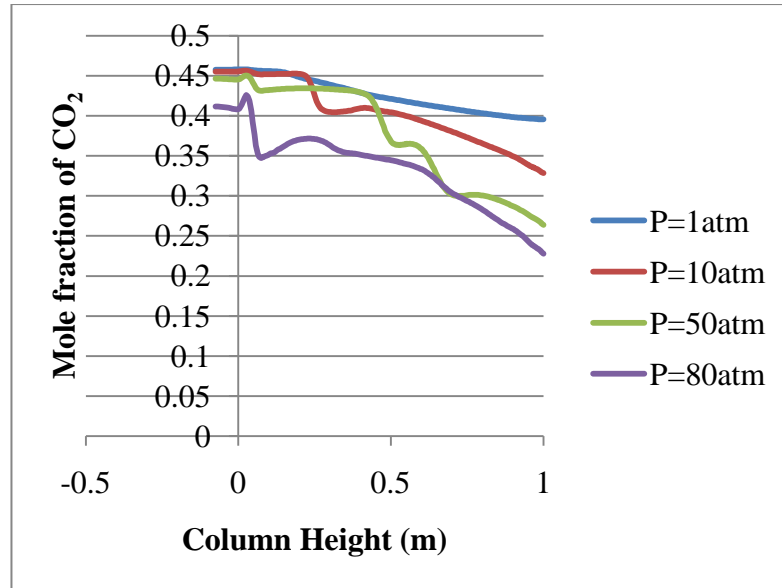

Figure 13: Influence of superficial velocity of specially designed solvent at 0.016m/s and natural gas of 28m/s

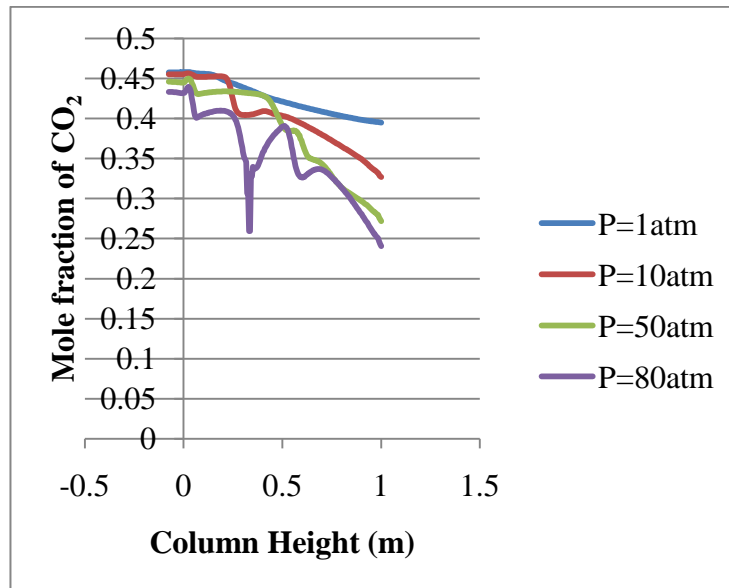
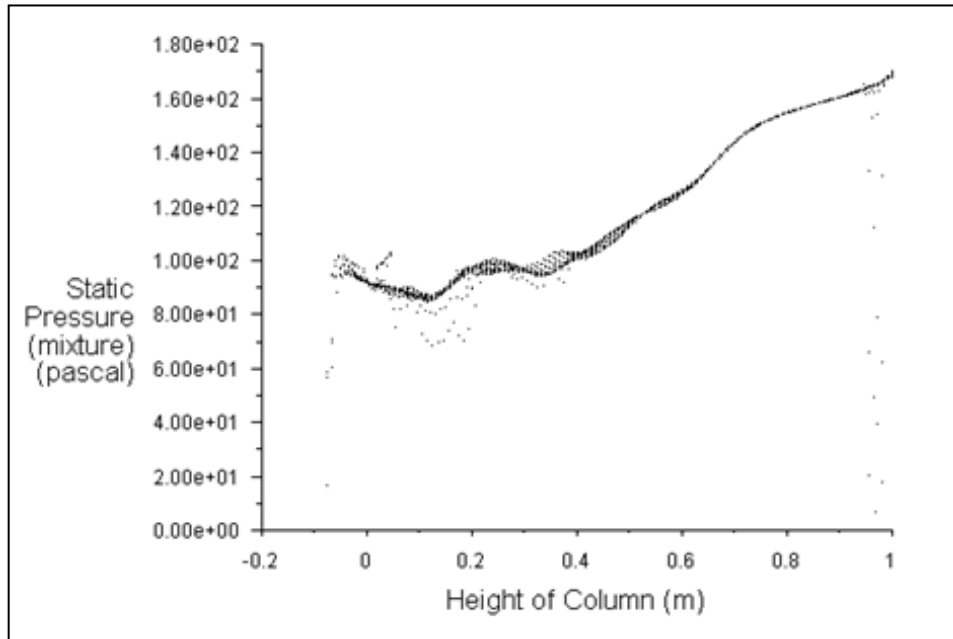

Figure 14: Influence of superficial velocity of specially designed solvent at 0.055m/s and natural gas of 28m/s

The pressure drop in contactor vessel is an important design for the absorption system. This is because higher pressure drop would increase the pumping power that increase the capital cost of the absorption system. In addition, this will also affect the performance of the contactor vessel. As a result, the pressure drop will

increase with the increase of the superficial gas and liquid velocities. The trend of pressure drop in the simulation is increase when increase in velocity.



(a)

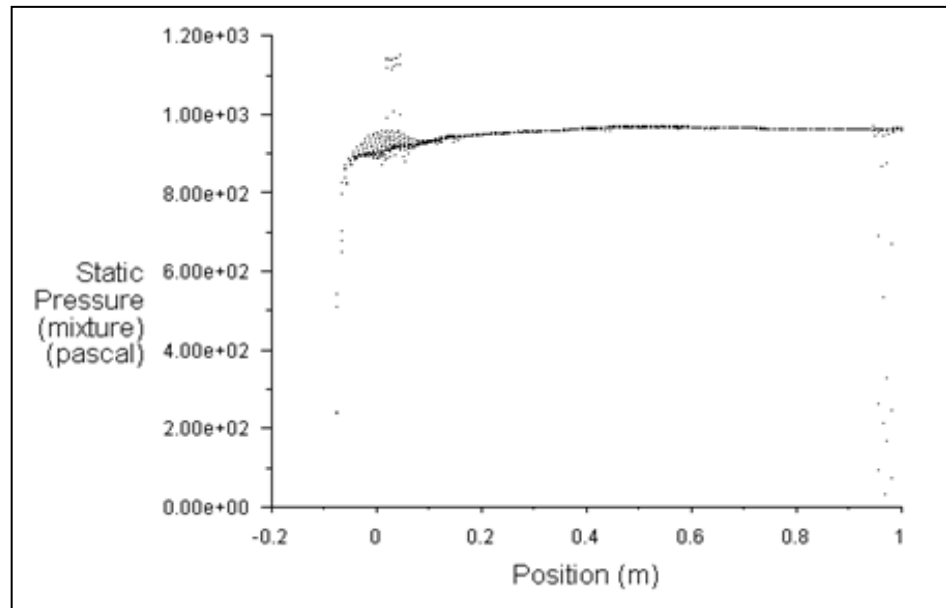

(b)

Figure 15: Total pressure drop with respect to column height at different natural gas superficial velocity of (a) 6 m/s, and (b) 28 m/s

The rate of pressure drop is at constant at the maximum velocity of 28 m/s, the pressure drop is almost independent of the velocity and it approaches a constant

value of 950 Pa whereas at velocity of 6 m/s the pressure drop is 170 Pa. Previous paper proposed a pressure drop correlation that shows pressure drop influenced by both liquid and gas superficial velocity [13]:

$$\Delta P = AU_{SL}^{\alpha}U_{SG}^{\beta} \quad (12)$$

Table 9: Pressure drop correlation at different natural gas superficial velocity

Flow configuration	A	α	β	Superficial Gas Velocity	Pressure Drop
Vertical downward	44	0.23	2	6 m/s	611.93 Pa
				28 m/s	13326.5 Pa

The parameters of A, α and β for the vertical downward configuration in Table 9 is used for the pressure drop correlation. From the correlation, it is validate that pressure drop shall increase with the increase of natural gas superficial velocity. This is because gas superficial velocity has the decreasing influence on the interstitial velocity as the system pressure increases. Hence, the bubble size of the natural gas also decreases with increase of pressure which shows that the removal efficiency is increased with the increase of operation pressure.

4.4. Temperature Profile

The temperature profile of the mixture in Figure 16 shows. The heat capacity of the solution is considered based on the operating temperature of 303.15K. The trend of the temperature profile at the single temperature of 299.8K marked reduction of loading. According to Dugas [32], the reduction of loading is adjusted by manipulating the inlet gas velocity in order to achieve the same amount of rich loading perform by Rocha et al. Furthermore, the different dimension and geometry of contactor vessel is also adjusted to achieve the same amount rich loading. The location of temperature bulge is closed to the bottom of the column that being validated form the experimental data. The temperature profile is also affected by the velocity of the specially designed solvent and the velocity of natural gas is kept at constant rate. At lower velocity of specially

designed solvent, the temperature profile in the contactor is much higher at the overhead of the contactor.

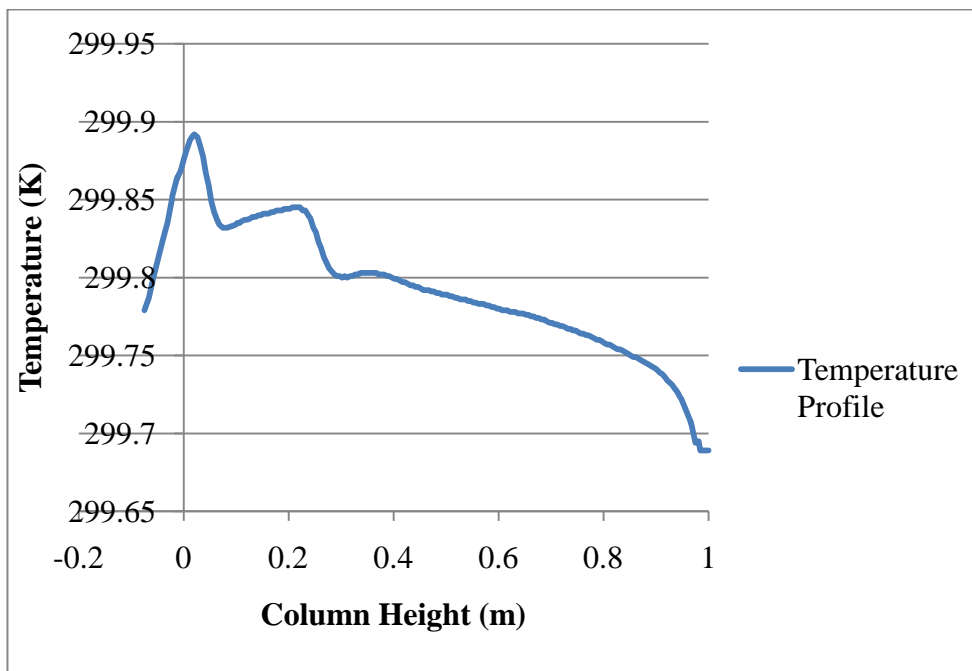

Figure 16: Temperature profile calculate by the model

4.5. Distribution of CO₂ concentration

Most of the CO₂ is absorbed at the centerline of the contactor when there is an excess of solvent including increase in operating pressure. The operating conditions in Figure 17 (a) and (b) is the CO₂ mole fraction contour along the column height at different operating pressure at 80atm and 10atm. The mole fraction of CO₂ at the inlet is 70mol%. The absorption rate of CO₂ is more rapidly at higher operation pressure which is explained in section 4.2.

Based on Figure 17, the mass transfer rate is relatively slow at the pressure of 10atm. The mole fraction of CO₂ is accumulated at the centerline of the contactor which follows the maximum value of gas phase velocity profile. For system that operates at 10atm, the reaches the value of 20mol% of CO₂ at the height of 0.8m whilst at 80atm, the interphase mass transfer is achieved at the height of 0.5m before the liquid and gas phase mass transfer in equilibrium as stated from Henry's constant. Henry constant is the ratio of the concentration

of a chemical substance in air to concentration in an aqueous solution at equilibrium.

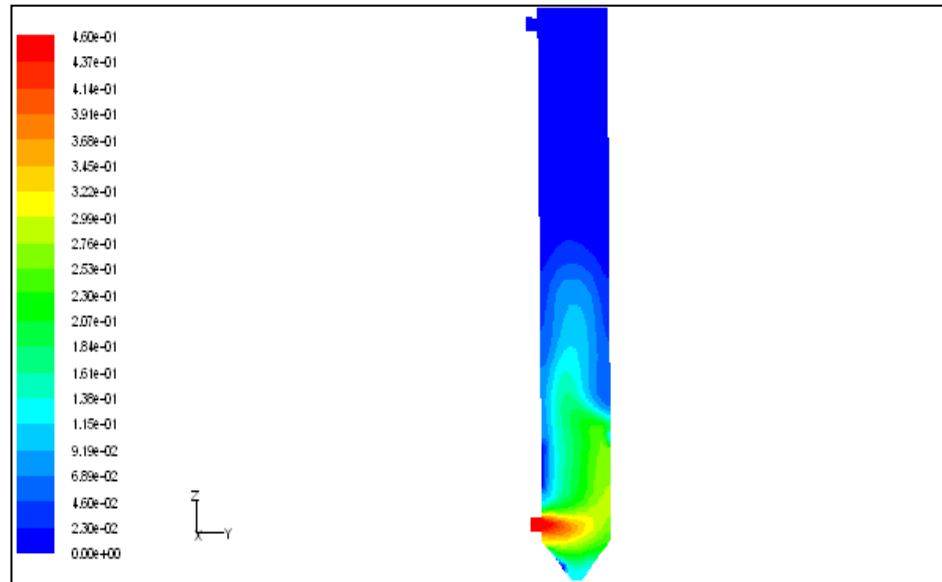

(a)

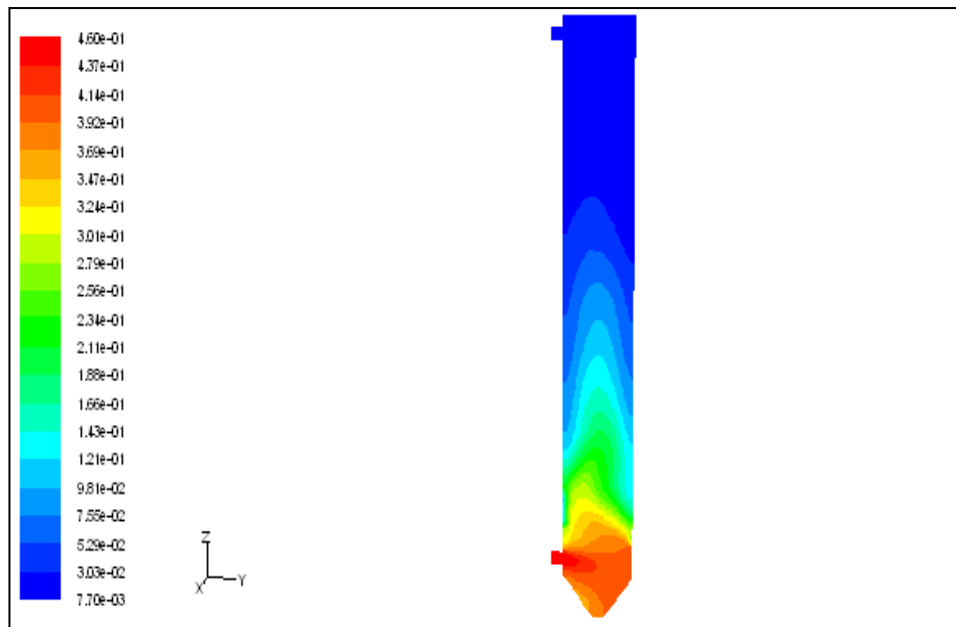

(b)

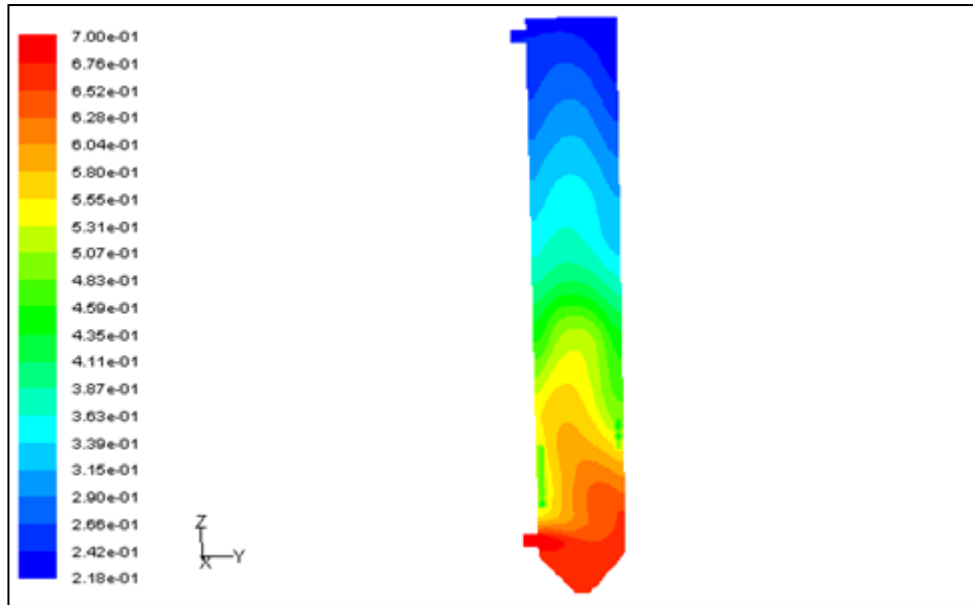

(c)

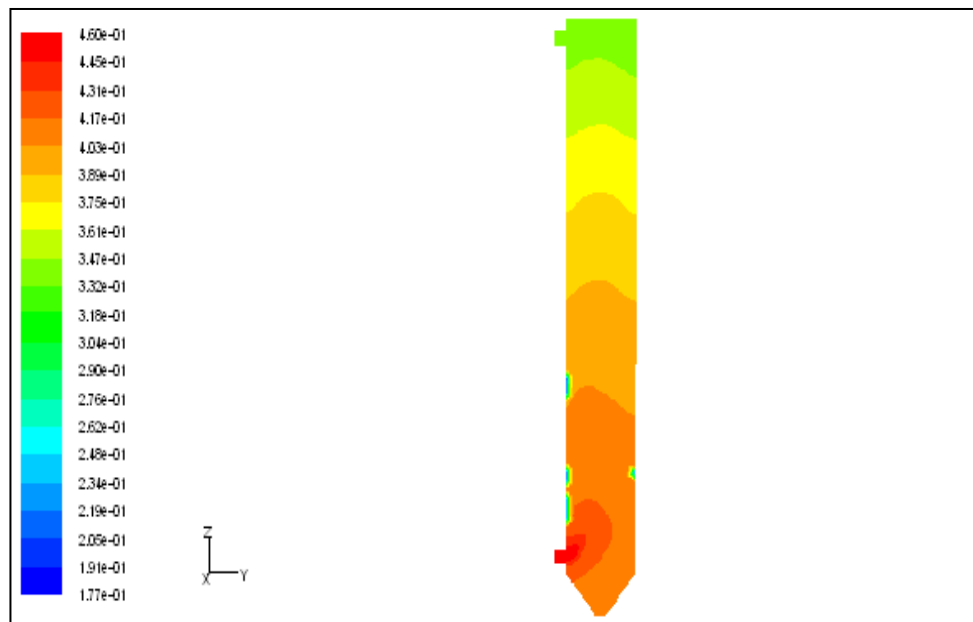

(d)

Figure 17: CO₂ concentration in absorption system (a) 80atm, (b) 50 atm, (c) 10atm and (d) 1atm. (constant $U_S = 0.055\text{m/s}$; $U_G=6\text{m/s}$)

The CO₂ concentration profile shows that with the increasing on pressure, the rate of mass transfer is more rapidly. The targeted of CO₂ concentration of 20mol% is achieved at lower column height at higher pressure compared to atmospheric pressure.

4.6. Contactor vessel cost estimation

The price for equipment is base on Time base mid 2004 [21], at the height of 1.0 m, the bare cost is \$2000.

The purchased cost is the multiplication of bare cost, material factor and pressure which given in Equation 10 is \$4400.

Thus, the total capital cost of constructing the contactor vessel based on Lang factor from Equation 9 is \$15,840.

CHAPTER 5

CONCLUSION AND RECOMMENDATION

5.1. Conclusion

The problem has been design to fulfill the intended objective of the project which is to simulate the mechanisms of diffusion between the liquid and gas phase in a controlled environment which some parameters are under controlled. The problem is designed for a specific experimental data from the previous papers that is reproduced.

The CO₂ content load is significantly influenced by the factors being studied which are the operating parameters, and both the superficial velocity of liquid and gas phases. The pressure drop is observed to be high at the highest pressure of 80 atm, yet the amount of CO₂ absorb into MEA is increases at higher pressure. Pressure is the driving force in mass transfer. Increasing the operating pressure led to increase in absorption rate and increasing in residence time for chemical absorption, higher CO₂ absorption could be achieved. Whilst, the condition for the superficial velocities of gas reduces the amount of CO₂ absorbed at higher velocity compared at highest superficial velocity of MEA.

Hence, by using the dimension of 1 m height and 0.15 m diameter, the column is best operated at the pressure of 80 atm and 30°C in temperature is the best parameters for absorption of CO₂ into MEA with the overall total cost of \$15840. The operation conditions for specially designed velocity is 0.055m/s where else the natural gas velocity is at 6m/s

5.2. Recommendations

Recommendations for future work are listed below:

1. Gas distributor should be included in the system to create higher interfacial area of gas to increase the contacting surfaces between CO₂ and specially designed solvent
2. Design a contactor vessel that can occupy the resins from the specially designed solvent and increase the absorption rate of CO₂ and scale up the contactor on the actual dimension of contactor vessel.

REFERENCES

- [1] Anonymous, 2004, <<http://www.naturalgas.org/overview/uses.asp>>
- [2] Xander Thong, 2003, “Price and Value Guide to Natural Gas Vehicle (NGV) conversion”, *Malaysian Gas Hybrid Vehicle*, <www.ngv.com.my/videos/437_mog_ngv_price_guide_proton_iswara.pdf>
- [3] U. S. Energy Information Administration, 2008, <http://www.eia.doe.gov/oiaf/ieo/nat_gas.html>
- [4] Anonymous, 2006, <<http://www.simtronics.com/catalog/spm/spm3100.htm>>
- [5] The Starbiz, July 2008, 14, <<http://biz.thestar.com.my/news/story.asp?file=/2008/7/14/business/21813487&ses=business>>
- [6] Nasir Haji Darman, Abd Rahman B Harun, 2006, “Technical Challenges and Solutions on Natural Gas Development in Malaysia,” *The petroleum Policy and Management (PPM) Project 4th Workshop of the China-Sichuan Basin Case Study*
- [7] Anonymous, 2004, <<http://www.naturalgas.org/overview/background.asp>>
- [8] Shiaoguo Chen, Yongqi Lu, and Massoud Rostam-Abadi, 2007, “Critical Review of Separation Technologies for CO₂ Capture from Post-Combustion Flue Gases”, <http://aiche.confex.com/aiche/s07/preliminaryprogram/abstract_80598.htm>
- [9] DOW Chemical Co., 1998, “Amine Gas Sweetening”, <http://www.dow.com/PublishedLiterature/dh_0039/0901b803800391f8.pdf?file_path=gastreating/pdfs/noreg/170-01395.pdf&fromPage=GetDoc>
- [10] Hongyi Dang, Gary T. Rochelle, 2001, “CO₂ absorption rate and solubility in Monoethanolamine/Piperazine/Water”, *Preparation for presentation at the First National Conference on Carbon Sequestration, Washington D. C.*

- [11] S. Schubert, M. Grunewald, D. W. Agar, 2001, "Enhancement of carbon dioxide absorption into aqueous methyldiethanolamine using immobilized activators", *Chemical Engineering Science*, 56, 6211 – 6216
- [12] Kazunori Uchiyama, Hirofumi Migita, Ryo Ohmura, Yasuhiko H. Mori, 2003, "Gas absorption into "string-of-beads" liquid flow with chemical reaction: application to carbon dioxide separation", *International Journal of Heat and Mass Transfer*, 46, 457 – 468
- [13] C. Sanchez, A. Couvert, A. Laplanche, C. Renner, 2007, "Hydrodynamic and mass transfer in a new co-current two-phase flow gas-liquid contactor", *Chemical Engineering Journal*, 131, 49 – 58
- [14] D. Darmana, R. L. B. Hneket, N. G. Deen, J. A. M. Kuipers, 2007, "Detailed modeling of hydrodynamics, mass transfer and chemical reactions in bubble column using a discrete bubble model: Chemisorption of CO₂ into NaOH solution, numerical and experimental study", *Chemical Engineering Science*, 62, 2556 – 2575
- [15] M. T. Dhotre, J. B. Joshi, 2007, "Design of a gas distributor: Three-dimensional CFD simulation of a coupled system consisting of a chamber and a bubble column", *Chemical Engineering Journal*, 125, 149 – 163
- [16] Jeffery Kunts, Adisorn Aroonwilas, 2008, "Performance of Spray Column for CO₂ capture application", *Industrial Engineering Chemical Research*, 47, 145 – 153
- [17] Jaime A. Valencia, Robert D. Denton, "Method and Apparatus for separating carbon dioxide and other acid cases from methane by the use of distillation and a controlled freezing zone", 1985, *United States Patent*, 4533372
- [18] Guang Li, Xiaogang Yang, Gance Dai, 2009, "CFD simulation of effects of the configuration of gas distributors on gas-liquid flow and mixing in a bubble column", *Chemical Engineering Science*, 64, 5104 – 5116

- [19] LudovicRaynal, Oullins, Anne-Claire Lucquin, Saint-Maurice-l'Exil, 2008, "Deflecting system for column trays", *United States Patent Application Publication*, US 20080156746A1
- [20] M. Baniadam, J. Fathikalajahi, M. R. Rahimpour, 2009, "Incorporation of Eulerian-Eulerian CFD framework in mathematical modeling of chemical absorption of acid gases into methyl diethanol amine of sieve trays", *Chemical Engineering Journal*, 151, 286 – 294
- [21] R. K. Sinnott, 2005, *Coulson and Richardson's Chemical Engineering Design*, London, Elsevier
- [22] G. B. Liu, K. T. Yu, X. G. Yuan, C. J. Liu, Q. C. Guo, 2006, "Simulations of chemical absorption in pilot-scale and industrial-scale packed columns by computational mass transfer", *Chemical Engineering Science*, 61, 6511 – 6529
- [23] G. F. Versteeg, W. P. M. Vanswaaij, 1998, "On the kinetics between CO₂ and alkanolamines both in aqueous and non-aqueous solutions.1. Primary and secondary-amines", *Chemical Engineering Science*, 43, 573 – 585
- [24] J. Ko, T. Tsai, C. Lin, M. Li, 2001, "Diffusivity of nitrous oxide in aqueous alkanolamine solutions," *Journal of Chemical Engineering and Data*, 46, 160 – 165
- [25] Fluent Inc., 1995 – 2010, <<http://www.fluent.com/solutions/whatcfd.htm>>
- [26] VertMarkets Inc., 1996 – 2010, <http://www.poweronline.com/product.mvc/GAMBIT-Software-0001?VNETCOOKIE=NO>
- [27] Su-Hsia Lin, Pen-Chi Chiang, Chun-Fan Hsieh, Meng-Hui Li, Kuo-Lun Tung, 2008, "Absorption of carbon dioxide by the absorbent composed of piperazine and 2-amino-2-methyl-1-propanol in PVDF membrane contactor", *Journal of the Chinese Institutes of Chemical Engineers*, 39, 13 – 21

- [28] Rocha, J. A., Bravo, J. L., Fair, J. R., 1993, “Distillation Columns Containing Structured Packings: A Comprehensive Model for Their Performance. 1. Mass-Transfer Model”, *Industrial Chemical Engineering Research*, 35, 1660 – 1667
- [29] Onda, K., Takcuchi, H., Okumoto, Y., 1968, “Mass Transfer Coefficients between Gas and Liquid Phases in Packed Columns”, *Chemical Engineering Japan*, 1, 56 – 62
- [30] Rocha, J. A., Bravo, J. L., Fair, J. R., 1996, “Distillation Columns Containing Structured Packings: A Comprehensive Model for their Performance. Mass-Transfer Model.”, *Industrial Engineering Chemical Research*, 35, 641 – 651
- [31] Onda, K., Takcuchi, H., Okumoto, Y., 1968, “Mass Transfer Coefficients between Gas and Liquid Phases in Packed Columns”, *Journal Chemical Engineering Japan*, 1, 56 – 62
- [32] Dugas, R. E., 2006, “Pilot Plant Study of Carbon Dioxide Capture by Aqueous Monoethanolamine”, MSE Thesis. The University of Texas at Austin, TX.

APPENDIX

Attachment A – Vertical pressure vessels, Time based mid – 2004

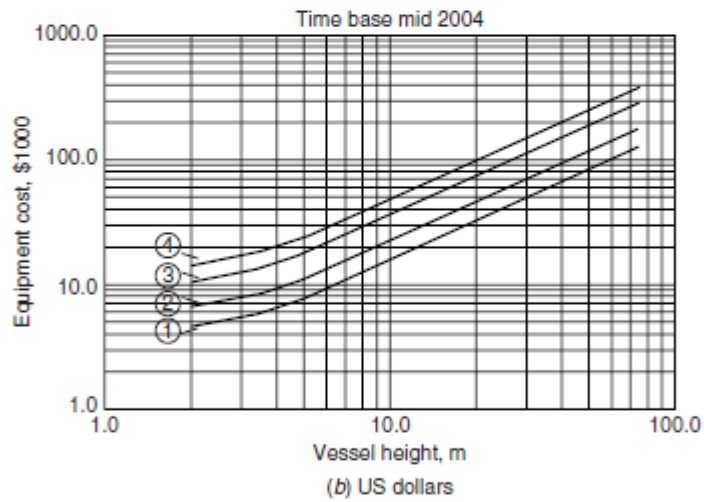
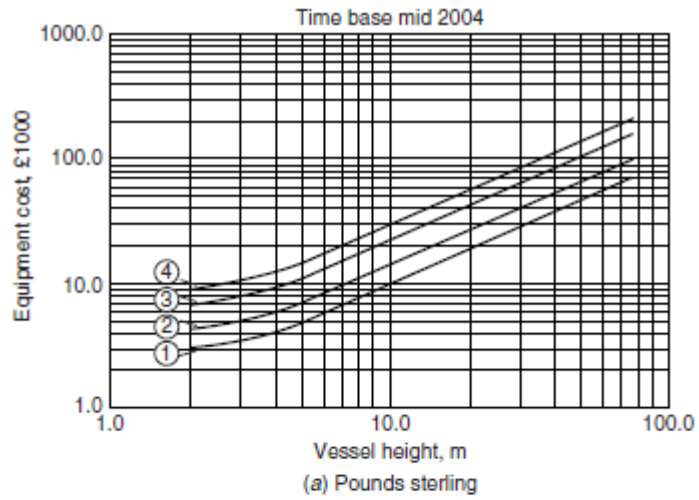

Diameter, m		Material factors	Pressure factors
①—0.5	③—2.0	C.S. × 1.0	1–5 bar × 1.0
②—1.0	④—3.0	S.S. × 2.0	5–10 × 1.1
		Monel × 3.4	10–20 × 1.2
		S.S. clad × 1.5	20–30 × 1.4
		Monel × 2.1	30–40 × 1.6
		clad	40–50 × 1.8
			50–60 × 2.2

Temperature up to 300°C