

DEVELOPMENT OF OPTIMUM SOLAR ELECTRICITY GENERATING SYSTEM

By

NURUL SYAFIQAH BINTI MOHD NAJIB

FINAL PROJECT REPORT

Submitted to the Department of Electrical & Electronic Engineering

In Partial Fulfilment of the Requirements

For the Degree

Bachelor of Engineering (Hons)

(Electrical & Electronic Engineering)

Universiti Teknologi PETRONAS

Bandar Seri Iskandar

31750 Tronoh

Perak Darul Ridzuan

© Copyright 2013

by

Nurul Syafiqah Binti Mohd Najib, 2013

CERTIFICATE OF APPROVAL

DEVELOPMENT OF OPTIMUM SOLAR ELECTRICITY GENERATING SYSTEM

By

Nurul Syafiqah Binti Mohd Najib

A project dissertation submitted to the
Department of Electrical & Electronic Engineering

Univerisiti Teknologi PETRONAS

In partial fulfilment of the requirement for the

Bachelor of Engineering (Hons)

(Electrical & Electronic Engineering)

Approved:

A.P. Dr. Balbir Singh Mahinder Singh

Project Supervisor

UNIVERSITI TEKNOLOGI PETRONAS

TRONOH, PERAK

December 2012

Abstract

The energy consumption in Malaysia has increased sharply in the process of achieving the goal of being a self-sufficient industrialized nation by year 2020. In order to meet this goal, Malaysia has been depending on large volume of the oil and gas found since 1970s. However, the emerging problem such as the oil and gas depletion and greenhouse gases effect has forced Malaysia and other countries all over the world in looking forward to implement renewable and sustainable energy resources to survive in the future.

Solar Electricity Generating System (SEGS) is one of the renewable energy resources that have a great opportunity to be widely implemented in Malaysia. Located at the equator, Malaysia received abundant of sunlight every year. However, SEGS in Malaysia is still in the initial state which needs more research and development to encounter the problem of inefficiency of the output power produced. The concept of optimization need to be further studied to make SEGS more reliable and sustainable.

This project studies about the optimum parameters needed to be implemented in a solar tracker. The optimization of solar photovoltaic based on SEGS includes the design on tracking mechanism, sensor position and the system sizing. This report contain the theoretical background and project activities on completing the trackers design, data logging and analysis of three different solar panel. The trackers designs are further completed by experimenting and improving the sensor holder to increase the sensitivity of the tracker toward light. Analysis of results are further discussed in this report after simulation studies in lab and outdoor experiments are conducted to compared the performance of three different solar panels.

Acknowledgement

First of all, deepest gratitude goes to Allah for providing me the opportunity to step in Universiti Teknologi Petronas and giving me strength in completing the studies and this final year project. Special thanks go to my helpful supervisor A.P. Dr. Balbir Singh. His invaluable help of supervision, constant support and suggestion throughout the progress have contributed to the success of this final year project.

My sincere appreciation to Predeep Menon who assisted me in using the data acquisition system. I will also like to thank my seniors, Nur Syamimie Che Aziz and Kalaimany A/L Arumuggam for their guidance during the early stages of this project. A special appreciation goes to Cik Ainul Azra and Encik M Adli M Yusof for their kind assistance and cooperation during my lab activities. All activities during the program would not be possible without the help and support from all of you.

Lastly, I will also like to thank my parents for their continuous support and prayers.

Table of Content

Contents

Abstract	iii
List of Figures	viii
Chapter 1: Introduction	1
1.1 Background of Study	1
1.2 Problem Statement	4
1.3 Objectives	5
1.4 Relevancy of the Project	5
1.5 Feasibility of the Project	5
Chapter 2: Literature Review	7
2.1 Solar Power Generation	7
2.2 Solar Photovoltaic System	10
2.3 Sun Tracking System	12
2.4 Solar Geometry	13
Chapter 3: Methodology	16
3.1 Research Methodology	16
3.1.1 Solar Photovoltaic System	16
3.1.2 Theoretical Development	16
3.1.3 Fixed Angle Solar Panel	17
3.1.4 Single-Axis Solar Tracker	18
.....	19
3.1.5 Dual-Axis Solar Tracker	20
3.2 Project Activities	21
3.2.1 Solar Insolation Data Collection	22
3.2.2 Sizing of Solar Photovoltaic System	25

3.2.3	Design of Tracker's Frame	26
3.3	Tools and Software	28
3.4	Gant Chart of FYP I.....	29
3.5	Key Milestone of FYP II.....	30
	Chapter 4: Results & Discussion	31
4.1	Solar Insolation Data.....	31
4.2	Design & Fabrication.....	33
4.3	Sensor Position.....	38
4.4	Output from Solar Panels.....	39
	Chapter 5: Conclusion.....	49
5.1	Solar Insolation Data.....	49
5.2	Solar Tracker Design & Fabrication	49
5.3	Sensor Position.....	49
5.3	Output from Three Solar Panels	50
	References.....	51

List of Table

Table 1: List of Renewable Power Project Approved by e-FiT as of 29th January 2012[2].....	3
Table 2 : Table of Sizing Calculation Summary.....	26
Table 3: List of Software & Hardware Used	28
Table 4: Hourly Solar Insolation Data	31

List of Figures

Figure 1: Graph of Electricity Generated & Demand from Different Sector [1].....	1
Figure 2: Carbon Dioxide Emission in Malaysia since year 2007 until 2011	2
Figure 3: Annual Power Generation of Renewable Energy under FiT System.....	4
Figure 4: Electricity Generation Mix (1995, 2003 and 2013) [12].....	7
Figure 5: OECD Electricity Production by Fuel Type in 2012 and 2013 [11]	8
Figure 6: Cumulative Value of the Renewable Energy in Malaysia (2011-2050) [13].....	9
Figure 7: Layers and Working Principle of Solar Cell [14].....	10
Figure 8 : Average Performance Ratio of Each Type of Solar Module [7].....	11
Figure 9: Type of Solar Tracker [15].....	12
Figure 10: Sun Path [17].....	14
Figure 11: Solar Angle.....	15
Figure 12: Basic Component in Solar PV System	16
Figure 13: Variation in Daily Tilt Angle of Solar Panel [19]	18
Figure 14: Sensor Response to Sunlight [20]	19
Figure 15: Single - Axis Solar Tracker Design.....	19
Figure 16: Process Flow of Single Axis Solar Tracker.....	19
Figure 17: Dual Axis Solar Tracker Design [21].....	20
Figure 18: Process Flow of Dual-Axis Solar Tracker.....	20
Figure 19: Experiment Process Flow	22
Figure 20: Solar Field Testing Facility	23
Figure 21: Solar Radiation Sensor	24
Figure 22: Data Taker	24
Figure 23: Mimic Digital Meter for Monitoring.....	25
Figure 24: Trend Chart for Monitoring.....	25
Figure 26: Mounting and Tracker 3D Drawing Design using Sketch Up software.....	27
Figure 27: Schematic Diagram of Sensor Circuit	27
Figure 28: Graph of Hourly Solar Insolation	32
Figure 29: Fixed Angled Solar Panel 3D drawing from the left side	33
Figure 30: Fixed Angled Solar Panel 3D Drawing from the front	33
Figure 31: Fixed Angled Solar Panel 3D drawing from right side	34
Figure 32: Single Axis Solar Panel 3D drawing from left side	34

Figure 33: Single Axis 3D drawing from the front.....	35
Figure 34: Single Axis Solar Panel 3D drawing from right side	35
Figure 35: Single Axis Solar Panel 3D drawing from back side	36
Figure 36: Dual Axis Solar Panel 3D drawing from left side.....	36
Figure 37: Dual Axis Solar Panel 3D drawing from right side.....	37
Figure 38: Dual Axis Solar Panel 3D drawing from right side.....	37
Figure 39: Experiment on Sensor Position	38
Figure 40: 'Inverted T' shape Sensor Holder.....	39
Figure 41: 'Triangle' shape Sensor Holder	39
Figure 42: Location of Three Solar Panels	40
Figure 43: Data Taker Web Interface	41
Figure 44: Data Studio software	41
Figure 45: Data Taker and Pasco Current Sensor	42
Figure 46: Pasco Data Logger and Laptop for Data Monitoring.....	42
Figure 47: Solar Insolation Data.....	43
Figure 48: Voltage from Fixed Angle Solar Panel	44
Figure 49: Voltage from Single Axis Solar Panel	44
Figure 50: Voltage from Dual Axis Solar Tracker	45
Figure 51: Short Circuit Current from Fixed Angle Solar Panel.....	46
Figure 52: Short Cuircuit Current from Single Axis Solar Panel	46
Figure 53: Short Circuit Current From Dual Axis Tracker.....	47
Figure 54: Output power produced by the three solar panels	47

Chapter 1: Introduction

1.1 Background of Study

Malaysia has experienced rapid development since 1970s and has introduced multi-sector economy to meet the goal of becoming developed nation by year 2020. Malaysia is now facing accelerating energy demand over the year evolution due to the process of achieving the goal of 2020. The increase in electricity demand and production from year to year has been analysed by Malaysia Energy Information Hub (MEIH) in Figure 1. [1] According to the data collected by MEIH, 43522 kilo tonnes of oil equivalent (Ktoe) were produced in year 2011 which is equal to 140897.45 GWh. The forecast growth of energy demand presented an increase of 3.7% in 2012 and expected to grow about 3.1% up till year 2020. [2]

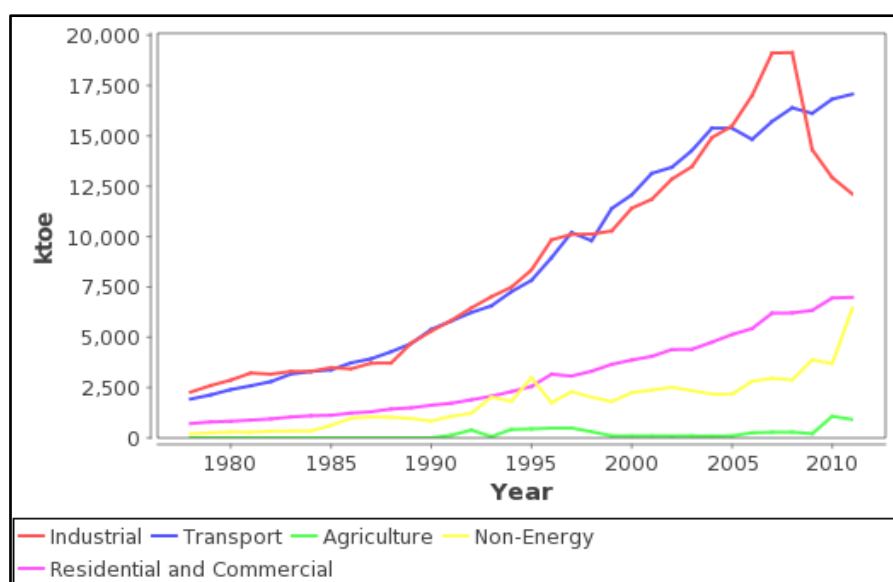

Figure 1: Graph of Electricity Generated & Demand from Different Sector [1]

Malaysia is one of the countries with large volume of oil and gas which was found in 1970s. In achieving the goal of 2020, Malaysia has become very dependent on oil and gas as the main fuel to fulfil energy demand from all sectors: industrial, transportation, agriculture, construction, domestic and others. However, it is undeniable that the non-renewable oil and gas resources might be depleted. According to Malaysia Analysis Brief available in Energy Information Agency website, Malaysia set a goal to become regional oil storage and maintain the reserve base to ensure long term supply security at the same time providing enough fuel for its population. In 2011, the government has reduced the total oil production to 630 000

barrels per day (bbl/d) compared to the previous year 2010 with oil production of 665 000 bbl/d. Malaysia now held proven oil reserves of 4 billion barrels as of January 2011 reported by Oil & Gas Journal (OGJ) and this has put Malaysia to be the third highest in the Asia-Pacific region after China and India. [3]

Beside oil depletion crisis, the effect of greenhouse gas (GHG) emission such as global warming, climate changes and the rising ocean has become a major security threat. It is agreed by Shell Malaysia chairman Mohd Anuar Taib that 60% of the total world GHG emissions today come from fossil fuel. Figure 2 shows the increasing graph of carbon dioxide emission in Malaysia from year 2007 to 2011 according to the collected data from U.S. Energy Information Agency website. [4] The Star Online has reported that Prime Minister Datuk Seri Najib Tun Razak represented Malaysia in United Nations Climate Change Conference 2009 has agreed to reduce 40% of the carbon dioxide emission by 2020 compared with the level recorded in 2005. [5] The Prime Minister has renewed his pledge in 6th June 2013 in promoting greener Malaysia and stated that the government fund RM2 billion for the Green Technology Financing Scheme. [6] The incentive spent by government has opened a huge opportunity for further research and development in renewable energy resources including solar electricity generation.

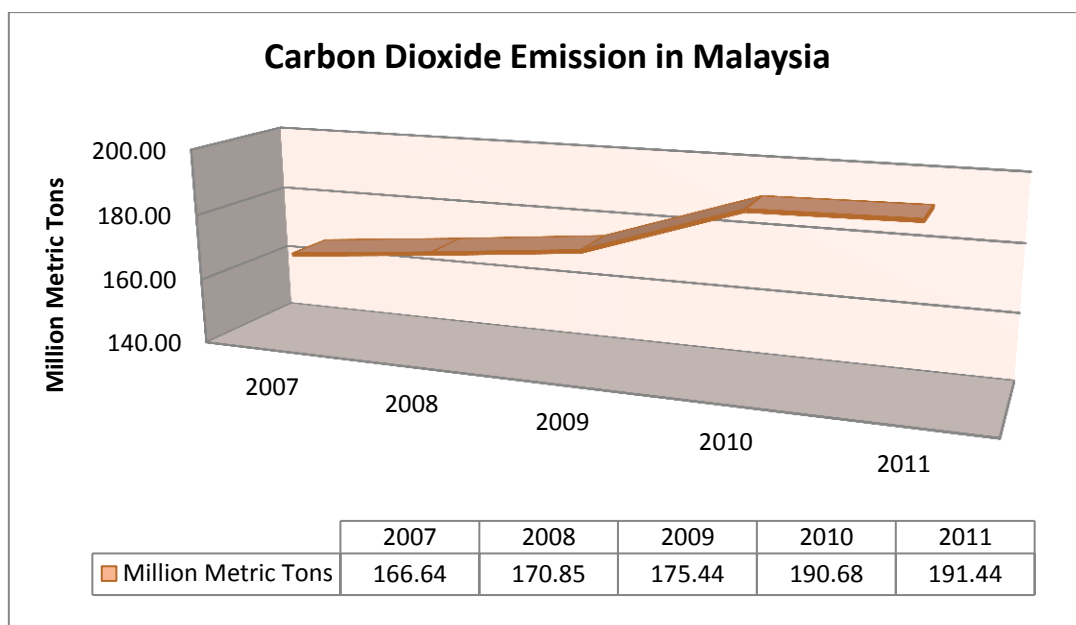

Figure 2: Carbon Dioxide Emission in Malaysia since year 2007 until 2011

In year 1981, the government introduced Four-Fuel Diversification Policy which added coal in the list of energy sources so it becomes oil, hydropower, gas and coal as key sources. This

policy is then further amended in year 2000 to add up renewable energy as a fifth fuel source to our fuel mix electricity generation. As of 29th February 2012, there were 337 renewable power projects approved for Feed-in-Tariff (FiT) with the total power capacity 311.56 MW. Table 1 lists all renewable projects applied with their total generating power. [2]

No.	Renewable Source	No. of Application	Capacity (MW)
1.	Biogas	10	14.48
2.	Biomass	8	91.80
3.	Small Hydropower	11	65.25
4.	Solar Photovoltaic (SEGS)	348	140.03
Total		377	311.56

Table 1: List of Renewable Power Project Approved by e-FiT as of 29th January 2012[2]

The renewable projects listed by the Ministry of Energy, Green Technology and Water in the Table 1 above shows that Solar Electricity Generating System (SEGS) contributed about 92.3 % from the total FiT projects. However, this majority number of SEGS only generated 44.9 % from the total power capacity. This analysis has proven that the utilization of solar energy is increasing but it is crucial to focus on comprehensive and concerted efforts in developing SEGS with high efficiency, reliability and sustainability.

Latest analysis is done by Sustainable Energy Development Authority Malaysia (SEDA) to prove the increasing amount of energy generated by renewable resources as shown in Figure 3. This graph summarised that each type of renewable energy sources has increased in year 2013 as compared to year 2012. The solar photovoltaic system reached up to 33702.97 MWh in 2013 which is 7 times higher than the previous year. This increasing number indicates the improvement in term of number of utilization and solar photovoltaic system efficiency.

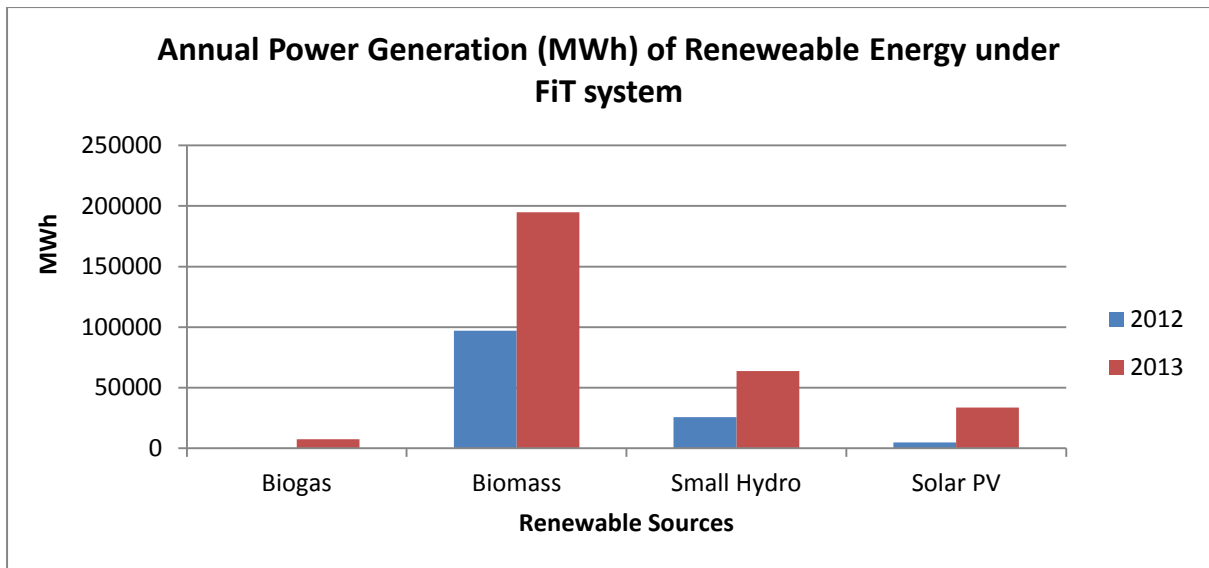

Figure 3: Annual Power Generation of Renewable Energy under FiT System

One of the challenges faced by SEGS is the apparent trajectory of the sun. Usually SEGS designers use a constant value of solar insolation which is $1000\text{W}/\text{m}^2$. However, value of solar insolation is constant outside the earth atmosphere and the actual amount of solar radiation received on the surface of earth ranges between $100\text{W}/\text{m}^2$ and $1000\text{W}/\text{m}^2$ which depends on the time of the day. The conversion efficiency of the PV is also very low, ranging between 10% and 17%, and at the same time, the cost to setup the SEGS is relatively high as well. There is a need to design an optimum SEGS to provide sustainable output.

1.2 Problem Statement

Although SEGS is rapidly becoming a popular choice for alternative power generation, but there is a need for a proper design to optimize the output. Besides, the cost for developing and implementing SEGS is relatively on the higher side at the moment. The design of SEGS must be optimized to improve the system efficiency relative to its cost. The amount of electrical power generated by the SEGS depends upon the amount of solar radiation received by PV. As the amount of solar radiation fluctuates, the output from the PV fluctuates as well. The design of SEGS also needs to consider when there is no power generation during the night time. Hence there is a need to include storage system as well.

The apparent trajectory of sun daily causes problem for the power generation, as SEGS installed especially in Malaysia is usually static. There is a need to determine the right orientation and tilt angle for the system, and the possibility of incorporating a sun tracking system. Due to these intermittent conditions, there is a need to design an optimum solar electricity generating system to ensure that the output is stable and sustainable.

1.3 Objectives

The objectives of this solar optimization project are:

- To carry out simulation studies to determine the optimum parameters of solar photovoltaic based solar electricity generating system.
- To design an optimum solar photovoltaic based on solar electricity generating system that utilizes sun tracking system.

1.4 Relevancy of the Project

The market of solar photovoltaic system nowadays is gaining high attention in Asia while it is abundantly used in America and Europe country quite some time. Malaysia is situated near to the equator with the latitude of 4.1936° N and longitude of 103.7249° E which has a tropical climate and high temperature. Malaysia receives abundant of sunlight throughout the year with the availability of 6 hours of direct sunlight per day. The average of solar radiation between 800 W/m^2 to 1000 W/m^2 [7] makes this country has a very bright potential in solar photovoltaic implementation. Therefore the effort to further researches on optimizing the solar photovoltaic system under Malaysia circumstances is relevant.

1.5 Feasibility of the Project

This study is conducted in the campus of Universiti Teknologi Petronas which is located in Seri Iskandar, Perak. Ipoh and Cameron are among the cities that receive the highest amount of solar radiation with monthly average of 17.96 MJ/m^2 and 16.31 MJ/m^2 . [8] A previous

study in Sri Iskandar has been done in year 2010 where the data of solar radiation are collected. The total radiation for the day is 4521.8 Wh/m². [9] Hence, it is feasible to further the study in optimizing photovoltaic based on SEGS in Universiti Teknologi Petronas, Seri Iskandar since the direct sunlight is received abundantly in the campus area. Besides, this study will be supported with the availability of tools, software and market technology such as solar radiation meter and data logger. The simulation study is conducted in lab and outdoor condition.

Chapter 2: Literature Review

2.1 Solar Power Generation

The potential solar electricity generation system implementation in Malaysia is very high due to its location very near to the equator with the latitude between 1.0° N and 6.0° N. Malaysia receives huge amount of sunlight throughout the year. The 6 hours of direct sunlight with an average daily solar insolation of 4.39 kWh/m² is a very good advantage for the implementation of SEGs. The monthly solar insolation is 133.0 kWh/m² and the standard value for annual is 1596.5 kWh/m². [10] However, the percentage of renewable energy in the electricity generation mix as shown in Figure 4 is still low while the other Asian countries, America and European countries has been harvesting renewable energy in larger number nowadays. The European countries such as United Kingdom, Ireland, Spain, Italy, Portugal and others can be taken as an example for investing a development in the usage of photovoltaic and other green renewable energy resources. The International Energy Agency (IEA) has reported that the all the countries mentioned above has increased percentage of using renewable energy up till March 2013 compared to March 2012. Portugal shows the highest rate of increase with 56.9% compared to previous year. [11]

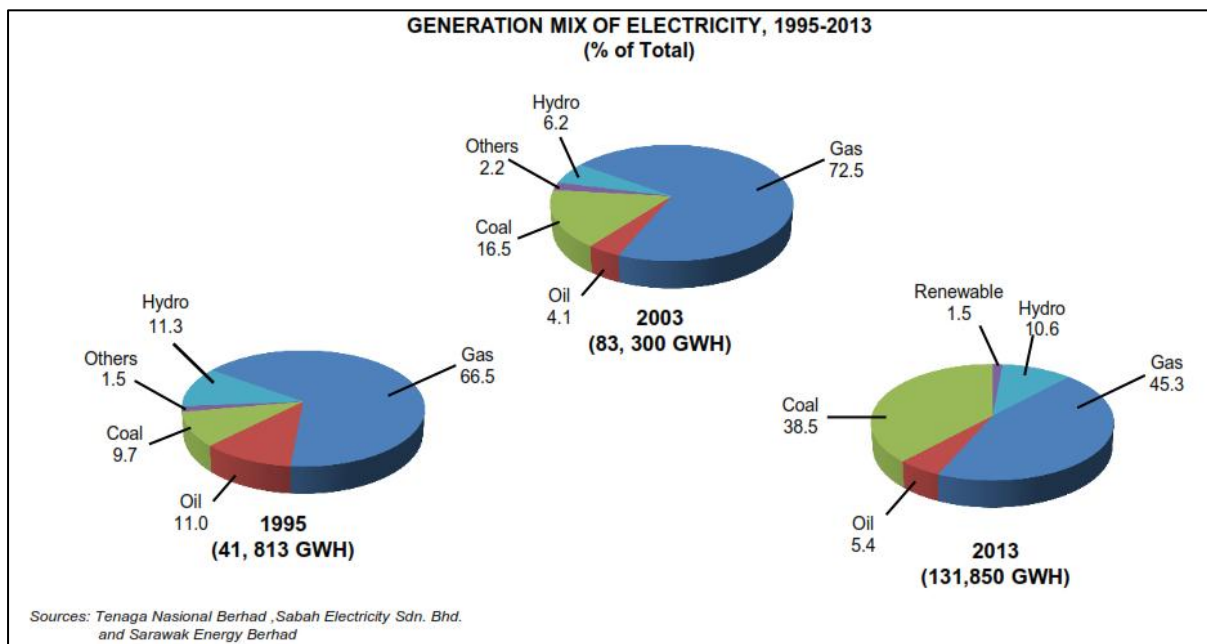

Figure 4: Electricity Generation Mix (1995, 2003 and 2013) [12]

The member countries for Organisation for Economic Co-operation and Development (OECD) of Europe and OECD America grew by 14.9% and 21.3% respectively. Beside that, Asian country such as Korea also has shown the growth of 56.8% in the usage of renewable energy resources. In overall, EIA has reported the members of OECD Total (OECD Americas, OECD Asia Oceania, OECD Europe), not including Malaysia, has increased the usage percentage of renewable energy resources including solar energy from 5% to 6% in the electricity production mix by this March 2013 compared to the previous year. While this renewable energy increased, the combustible fuels usage has reduced from 62% to 61% [11] as shown in Figure 5.

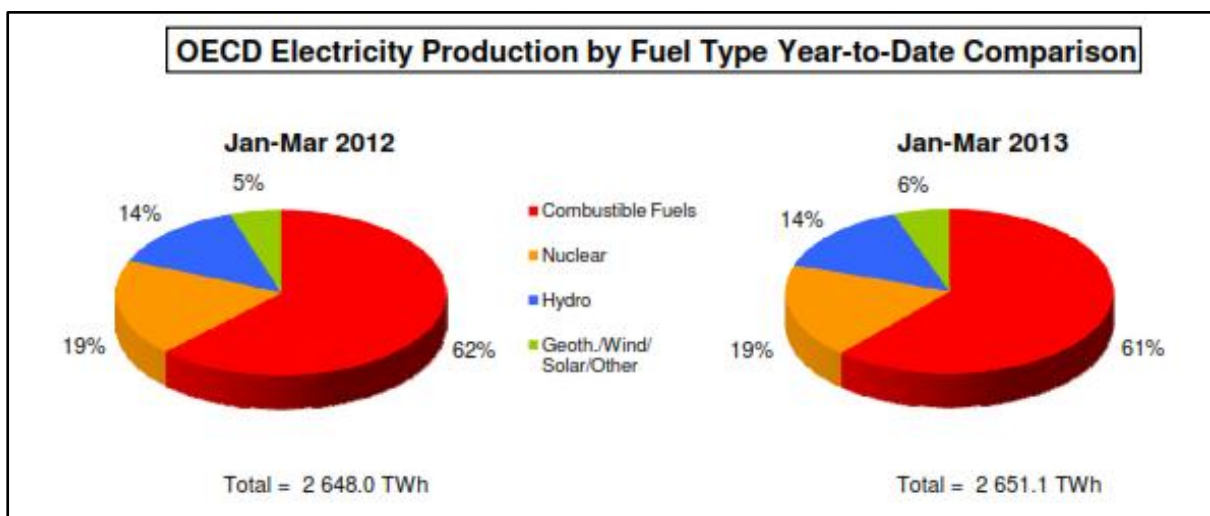

Figure 5: OECD Electricity Production by Fuel Type in 2012 and 2013 [11]

It is possible for Malaysia to depend on the solar PV system with Malaysia climate condition and at the same time acquire the benefit of using this free fuel (sunlight), minimal maintenance, longer service lifetime and no emitted pollution generated from this green technology. FiT system is proven to be the catalyst to inject more implementation on this renewable energy sources. With the plan of producing 11.5 GW by 2050, 9 GW is expected to be contributed by solar PV as illustrated in Figure 6 [13].

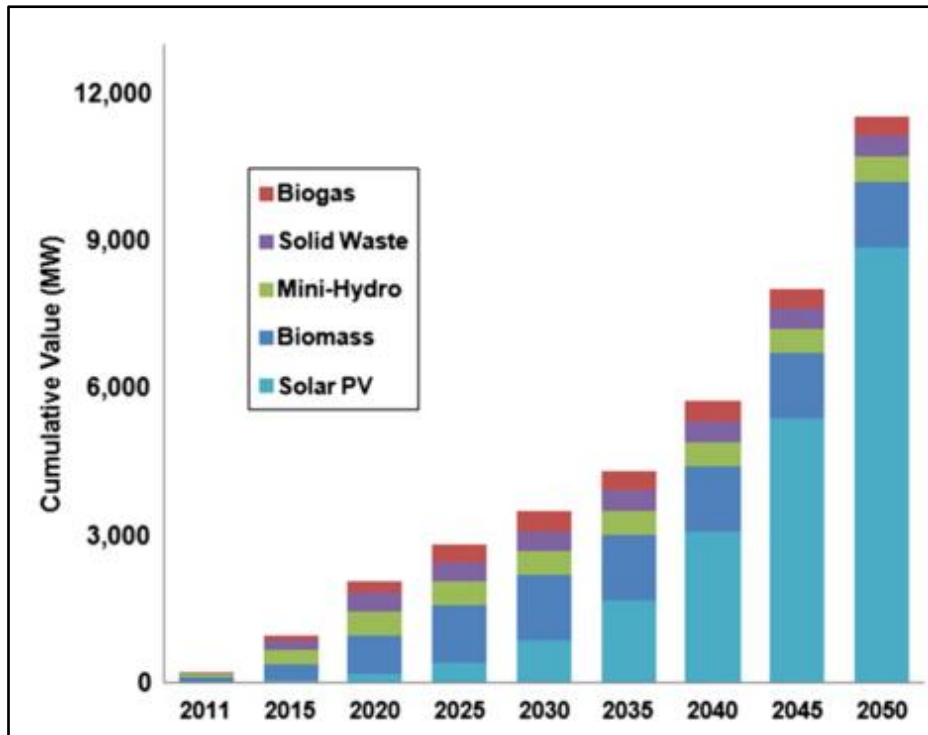

Figure 6: Cumulative Value of the Renewable Energy in Malaysia (2011-2050) [13]

2.2 Solar Photovoltaic System

Solar electricity generating system is an alternative energy sources that involves harnessing the radiant light energy emitted by the sun and converting it into electrical current. Basically, the surface receives about 47% of the total solar energy that reaches the Earth. In order to use this energy for our application in daily life, solar photovoltaic system is the technology that is need to capture this solar energy, concentrate it, store it, and convert it into electrical energy.

In solar photovoltaic, unique properties of semiconductors is used to directly convert solar radiation into electricity. The principle of doping process happen to the n-type and p-type material take place in order for the electrons to move to produce the direct current. The n-type wafer is made up of phosphorus and p-type wafer is made of boron. The photoelectric effect principle started when the light strike the surface of material which makes the electrons released. When photon of light is absorbed by one of these atoms in the n-type silicon, it will remove an electron, creating a free electron and hole. The free electron and hole has sufficient energy to jump out of the depletion zone. The electron attracted to the positive charge (p-type) and travel through the wire creating a flow of current. The hole leaving by the electron attracted to the n-type to create voltage. This whole process is easier to be explained with the aid of the solar cell illustration in Figure 7. [14]

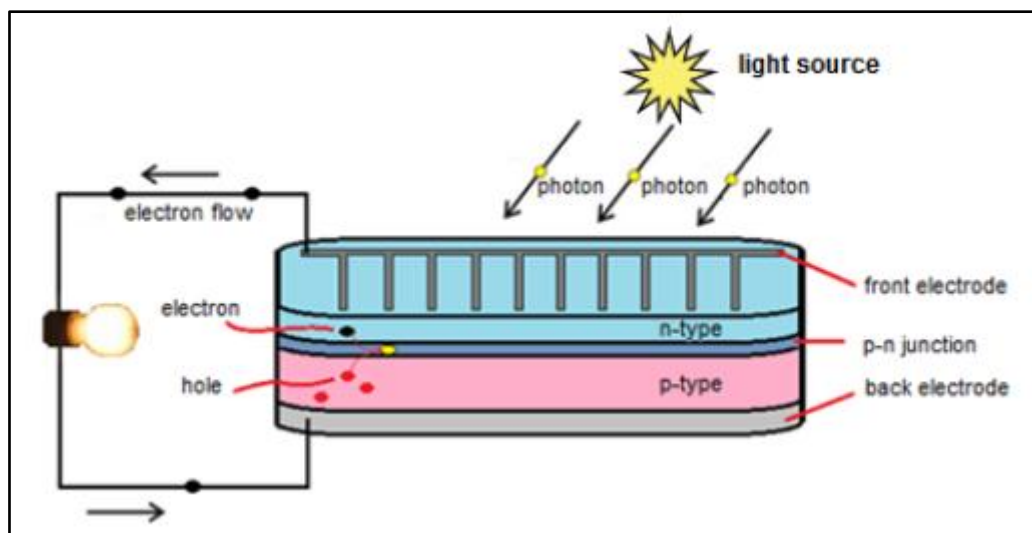

Figure 7: Layers and Working Principle of Solar Cell [14]

The solar cell itself has many types with the different efficiency and performances. The types of solar cell available now are mono-crystalline silicon, multi-crystalline silicon, thin film

and amorphous silicon. The market trend has shown that mono-crystalline silicon have better performance since it is tested and followed with The Standard Test Condition (STC) which specifies the ambient temperature to be 25°C. There are many study demonstrated under Malaysia climate condition which has proven that Amorphous silicon and CIS solar cell shows better performance ratio for Malaysia weather condition which use the average temperature about 42°C. The graph plotted in Figure 6 shows that thin film technology can produce more power in Malaysia so there is no need to follow the market trend which promotes mono and multi-crystalline silicon that satisfies weather condition outside Malaysia. [7]

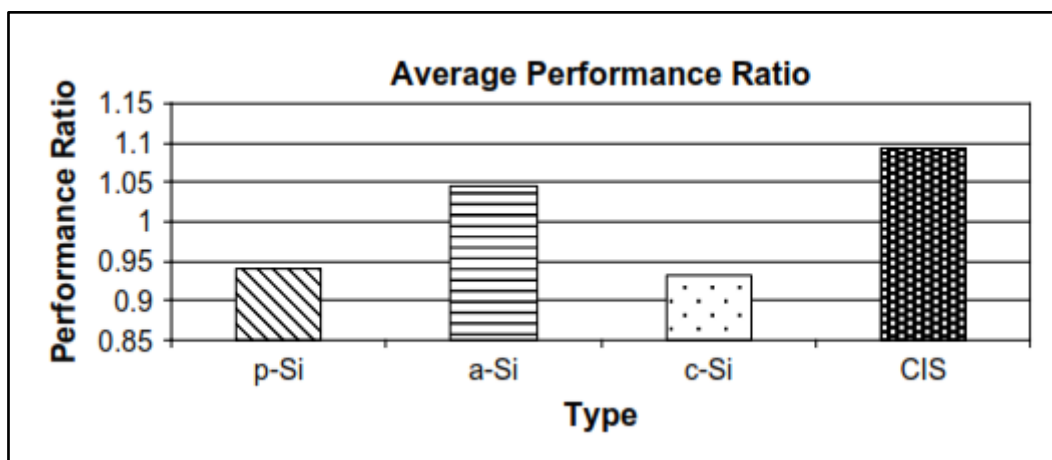

Figure 8 : Average Performance Ratio of Each Type of Solar Module [7]

There are four primary components used as a complete system to produce electricity from solar power: solar panels, charge controller battery and inverter. Solar panel wattage is determined by multiplying the rated voltage and rated amperage. Solar panel can be wired in series or parallel or both for the purpose of increasing the voltage or amperage respectively. Solar panel with series connection will produce voltage the sum of the two panels while the amperage stays the same as one panel. The parallel connection then produce the same voltage amount but increases the amperage to be the sum of the number of panels.

In the day when there is the availability of sunlight, the solar panel will charge the battery. Amp Hours can be defined as the amount of current which can be supplied by the battery over the period of hours. The most important thing about battery characteristic is the need to ensure sufficient amp hour capacity to supply power during a long period of no sun and the extremely cloudy condition.

During the charging process, charge controller is needed to ensure proper charging. It is crucial to ensure that the battery is not overly charged to avoid the risk damaging the battery and other potential safety concern. In photovoltaic system, the electrical current produced is in the form of direct current. An inverter is a device that can be used change DC power stored in the battery to standard 120/240 VAC electricity which suit normal appliances.

2.3 Sun Tracking System

After using a flat solar panel, people start to find a better way to maximize the energy capture from the sun light. The solar panel need to be facing the sun so the light can be directly accepted. A lot of fixed angle solar panels are installed and proven to be more efficient over the flat solar panel. However, the fixed solar panel can only concentrated the sunlight during within few hours interval and the solar panel will not be capturing the light at the other angle. In order to improve the output efficiency from the solar panel, the orientation must be continually adjusted to face sun beam as the sun traverses the sky. There are two category of solar tracker as illustrated in Figure 9.

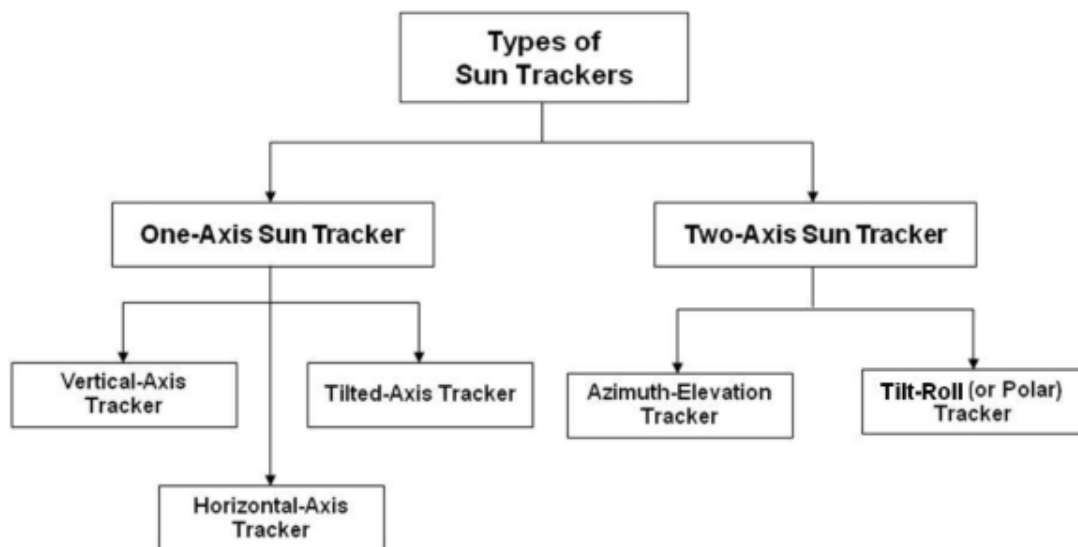

Figure 9: Type of Solar Tracker [15]

Single-axis solar tracker or stated as one-axis solar tracker is then divided into three categories. The vertical-axis solar tracker is basically changing the orientation of the solar panel based on the movement of sun daily. This type of solar tracker follows the azimuth

angle to decrease the incidence angle of the sun which will be discussed in detail in the solar geometry section. The tilted-axis tracker or sometime called inclined-axis tracker is tracking the sun from north to south which is tilted at the angle same with latitude angle. Horizontal-axis tracker is will remain parallel to the surface of the earth and it is oriented along east-west or north-south direction. [15] Two-axis or dual-axis solar tracker can track both directions, from east to west and from north to south at a time. This type of solar tracker is claimed to improve the output efficiency up to 40% for the countries experience 4 seasons due to equinoxes and solstices. In overall, the single-axis solar tracker is claimed to improve the output around 27% to 32% while the dual-axis tracker has improved up to 40% of the output efficiency. [16]

The existing solar trackers designed today by other researches and market place are using microcontroller or voltage regulator to make the solar panel move according to sun movement. This project approach is different on the tracking mechanism where servo driver is used to move the solar panel. The servo driver receives the input from light dependent resistor (LDR) and holds the servo rotor to certain angle depending on the certain value of resistance balanced coming from two sensors. Below is the circuit diagram of the servo driver used.

2.4 Solar Geometry

The knowledge of solar geometry is important in finding the best mechanism for solar tracking system. The solar geometry will establish the theoretical data of seasonal and hourly changing position of the sun. These changes of sun's position will give a big influence to the angle of incidence of sunlight. Thus, solar geometry is used to design a system that can adjust the solar collector based on sun's position and minimize the incidence angle of the solar beam to the horizontal plane of the earth. As a result, the continuously adjusted solar collector throughout the day and the year will maximize its output efficiency.

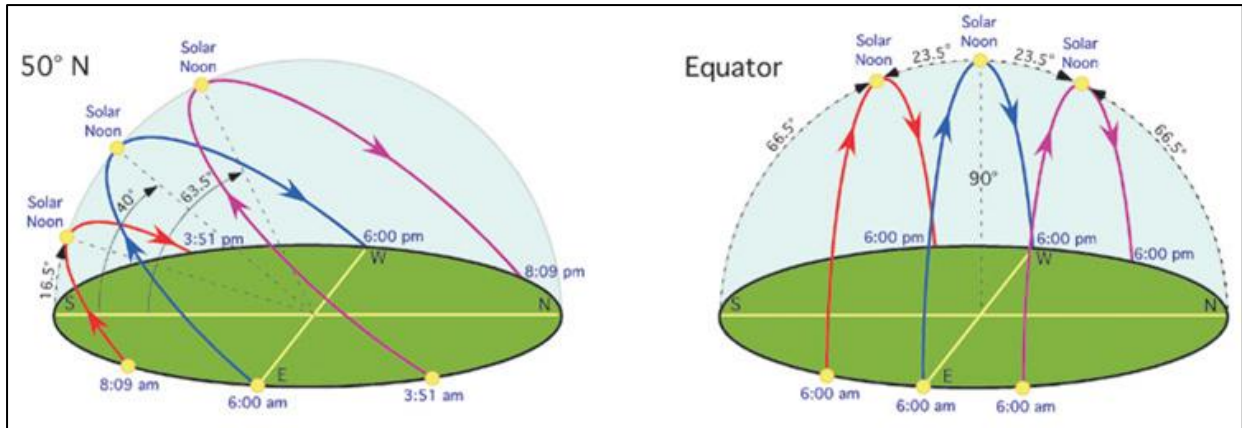

Figure 10: Sun Path [17]

Since the sun path are changing from east to west and from north to south, many type of angle need to be determined to get the optimum solar angle. Below are the summary of the solar geometry angles [8], [18]:

- i. **Zenith Angle, θ_z** – Zenith Angle is the angle distance between the subsolar point and the current place latitude.
- ii. **Elevation Angle, α_s** – Angle between the lines that point to the sun and the horizontal plane. Sun angle is the complement of Zenith Angle (Sun Angle = $90^\circ - \text{Zenith Angle}$). Some other sources call this as beam angle, elevation angle and solar altitude angle.
- iii. **Solar Azimuth Angle, γ_s** – The angle between the line that point to the sun and the line that point to the south.
- iv. **Surface Azimuth Angle, γ** – The angle between the line that points straight out of the photovoltaic panel and south.
- v. **Declination Angle, δ** – Declination Angle varies seasonally due to the tilt of the Earth on its axis of rotation and rotation of Earth around the sun. The range of the angle will change from 23.45° to 0° and then to -23.45° .
- vi. **Angle of Incidence, θ** – Angle between the line that point to the sun and the angle that point straight out of the solar photovoltaic panel.

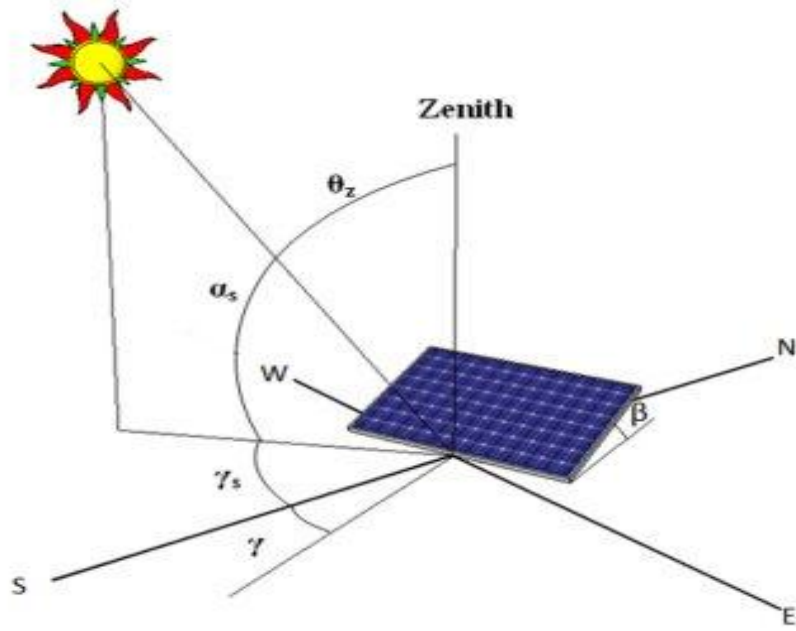

Figure 11: Solar Angle

Chapter 3: Methodology

3.1 Research Methodology

3.1.1 Solar Photovoltaic System

In order to find the optimum characteristic of solar panel under Malaysia's weather condition, three solar panels will be constructed according to this typical system as shown in Figure. One solar panel will be constructed to be the fixed angle solar panel and another two of them will be applying solar tracker. The basic components in solar photovoltaic system are solar panels, battery, charge controller, inverter and the load applied which can be both DC and AC load.

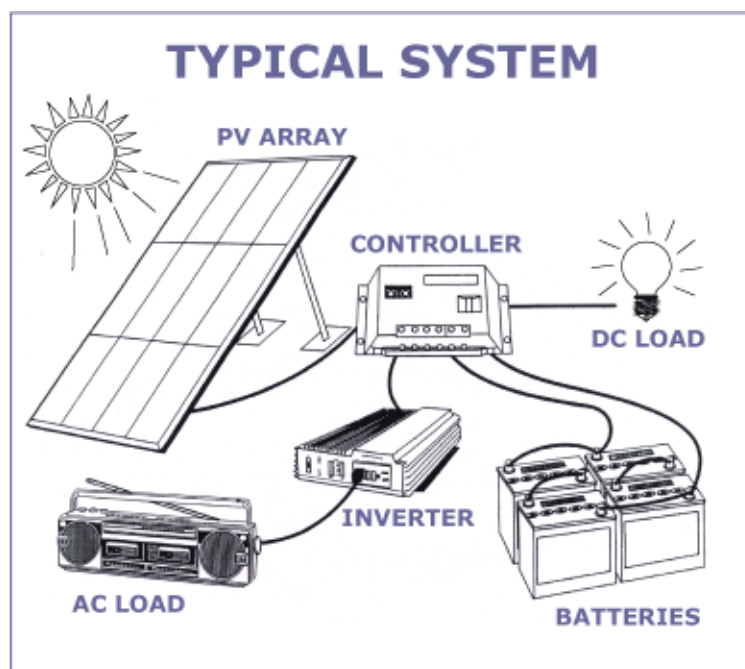

Figure 12: Basic Component in Solar PV System

3.1.2 Theoretical Development

In order to find the most suitable tilt angle of the solar panel from the horizontal plane, some parameters need to be determined by performing calculations. Our aim is to get the angle of incidence, θ equal to 90° . The value of θ can be adjusted by using Equation 3.1 below.

$$\theta = \cos^{-1} (A - B + C + D + E)$$

The variable A, B, C, D and E can be obtained from the Equation 3.2 to Equation 3.6.

$$A = \sin \delta \sin \Phi \cos \beta$$

$$B = \sin \delta \cos \Phi \sin \beta \cos \gamma$$

$$C = \cos \delta \cos \Phi \cos \beta \cos \omega$$

$$D = \cos \delta \sin \Phi \sin \beta \cos \gamma \cos \omega$$

$$E = \cos \delta \sin \beta \sin \gamma \sin \omega$$

The angles that are used in the list of equation above are the angle of declination δ , hour angle ω , surface azimuth angle γ , slope angle β and latitude Φ as discussed in the literature review section.

3.1.3 Fixed Angle Solar Panel

Fixed angle solar panel is invented after the flat solar panel to increase the output power. The solar panel need to be facing the sun at which the angle of incidence of the solar panel and the sun beam is 90° . The angle of tilt for the solar panel will vary according to the place and latitude. The angle needed for the northern hemisphere is different from the southern hemisphere. Malaysia as the equatorial country also has different solar panel angle of tilt to be considered.

The common practice of deciding the tilt angle of solar panel is by determining the latitude of a place. In Malaysia, the solar panel tilt angle β is equal to the latitude around 4° north. Malaysia located at the northern hemisphere so the solar panel should face to the south. It is also found by theoretical calculation, that maximum irradiation can be captured in Ipoh, Malaysia by positioning the PV modules at the monthly optimum tilt of $\beta_{\text{optimum}} = \varphi - \delta$, facing South ($\gamma = 0^\circ$) when β_{optimum} is positive or facing North ($\gamma = 180^\circ$) when β_{optimum} is negative. [19] From the graph shown in Figure 11, the theoretical calculation gives changing values of β_{optimum} on every single day. However it is almost impossible to change the position of solar collector almost every day since it needs as it will incur tedious mechanical work. Hence, this

project will implement the a fixed solar panel system of β equal to the latitude angle of 4.37° and facing true south. The varying value of β_{optimum} daily will be implemented in designing the single and dual-solar tracking system.

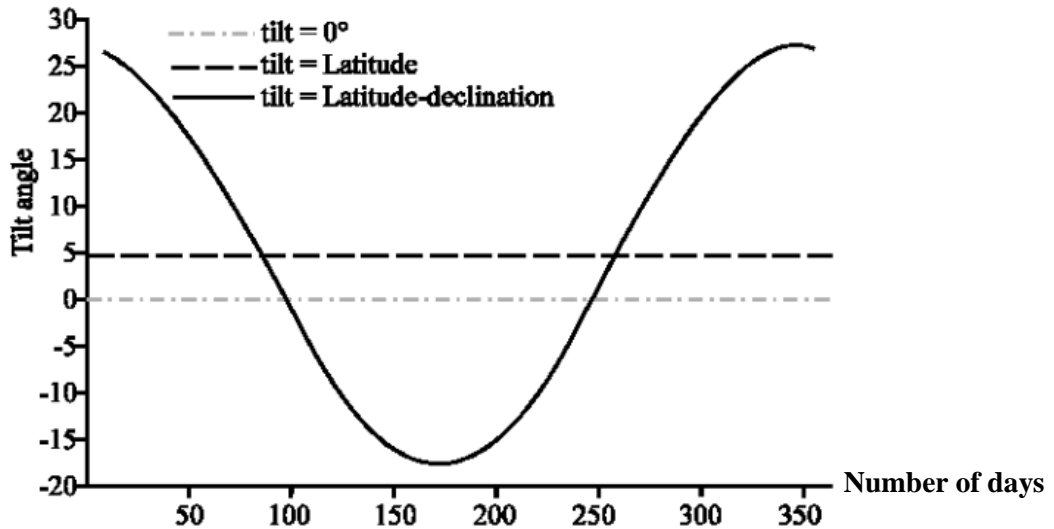

Figure 13: Variation in Daily Tilt Angle of Solar Panel [19]

3.1.4 Single-Axis Solar Tracker

A basic single-axis solar tracker will be built based on a simple light detection by light sensor and the rotation of motor. This single-axis solar tracker will be designed to track the sun in azimuth rotation or known as daily sun path from early morning to late evening before dark. The light sensor circuit will determine the position of the sun throughout the day and send the signal to the servo driver to control the motor movement. The detection of the light from Light Dependent Resistor (LDR) in Figure 14 [20] is simple and tolerable enough for a small scale solar tracking system without microcontroller. The movement of the DC motor direct the orientation of the frame axis weather to move to east or west.

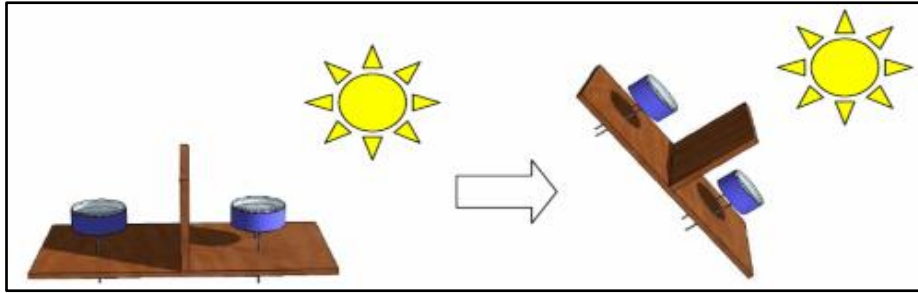

Figure 14: Sensor Response to Sunlight [20]

A prototype of single-axis solar tracker will be fabricated which the design concept is similar as shown in Figure 15. The design is a flat positioned solar panel and rotating from east to west. The process flow of how the single-axis solar tracker works is shown in Figure 16. At this point, the solar panel will be facing the sun at better angle along the day.

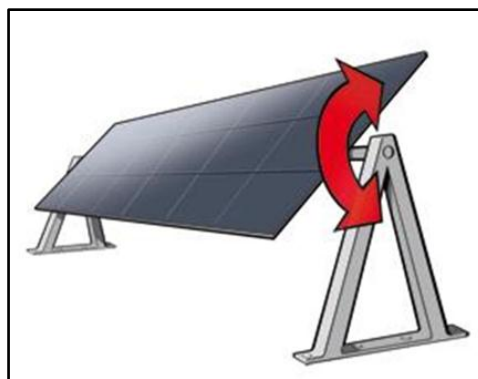

Figure 15: Single - Axis Solar Tracker Design

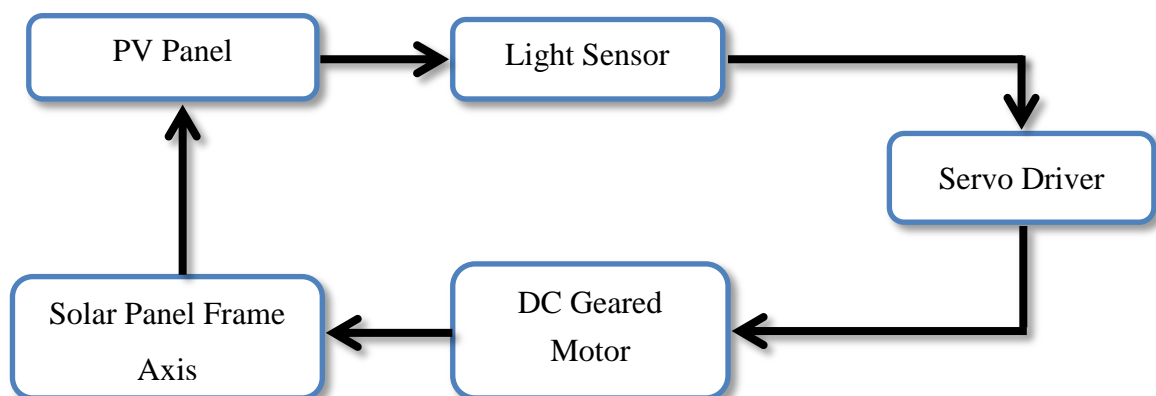

Figure 16: Process Flow of Single Axis Solar Tracker

3.1.5 Dual-Axis Solar Tracker

Dual-axis solar tracker is also implementing the same basic concept as the single-axis tracker which uses the LDR to detect sunlight motion. The difference between these two types of solar tracker the number of frame axis installed. Dual-axis solar tracker is designed to control the solar panel in both azimuth angle and altitude angle. As the azimuth rotation will control the solar panel movement from day to night, the altitude rotation will direct the solar panel to follow the sun path from north to south which changes according to solstices and equinoxes. Both LDR will sense the sunlight at a time and both servo drivers will control the motor rotation in each difference in the position of sunlight. Figure 18 shows the process flow of how dual-axis work to get the best optimum angle.

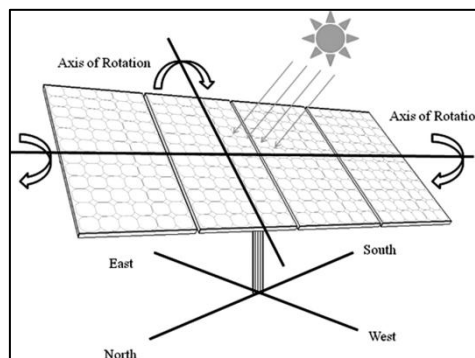

Figure 17: Dual Axis Solar Tracker Design [21]

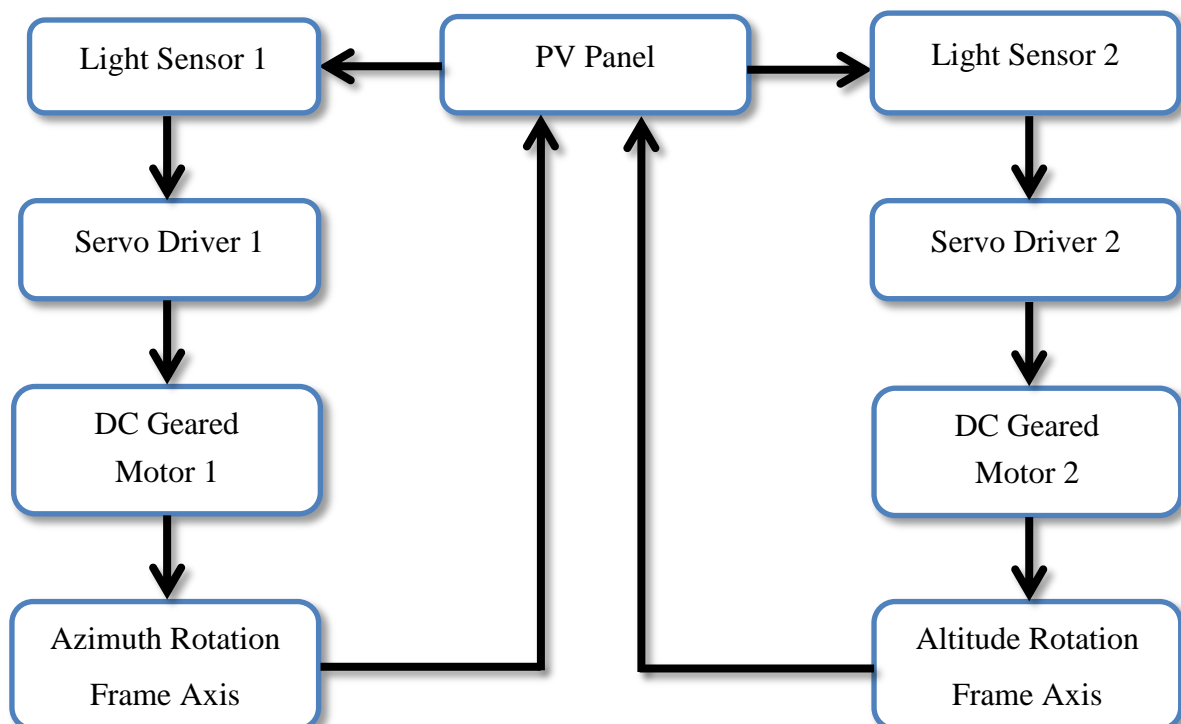

Figure 18: Process Flow of Dual-Axis Solar Tracker

3.2 Project Activities

The project starts with the collection and analysis of solar insolation data to know the reading of solar radiation in the campus of Universiti Teknologi Petronas. With solar insolation data, we can calculate the value of average solar sun hour in a day which needed to be used in the sizing calculation of Solar Electricity Generating System. Meanwhile, the design and fabrication work to produce three types of solar panels are implemented based on the SEGS parameter determined from the literature review made. As the fabrication work and system sizing are done, the experimental work can be initiated to study the efficiency of all four type of solar panel with different tracking mechanism. The output power from all three panels will be analysed based on the data gained in the experiment. The performance of each solar panel can be evaluated from the analysis of solar radiation received on the collector, maximum hourly electrical power, short circuit current, open circuit voltage and efficiency gain. With the output gained, the comparison and conclusion can be made according to the output efficiency of solar panels under Malaysia climate. The project flow is drafted in Figure 19.

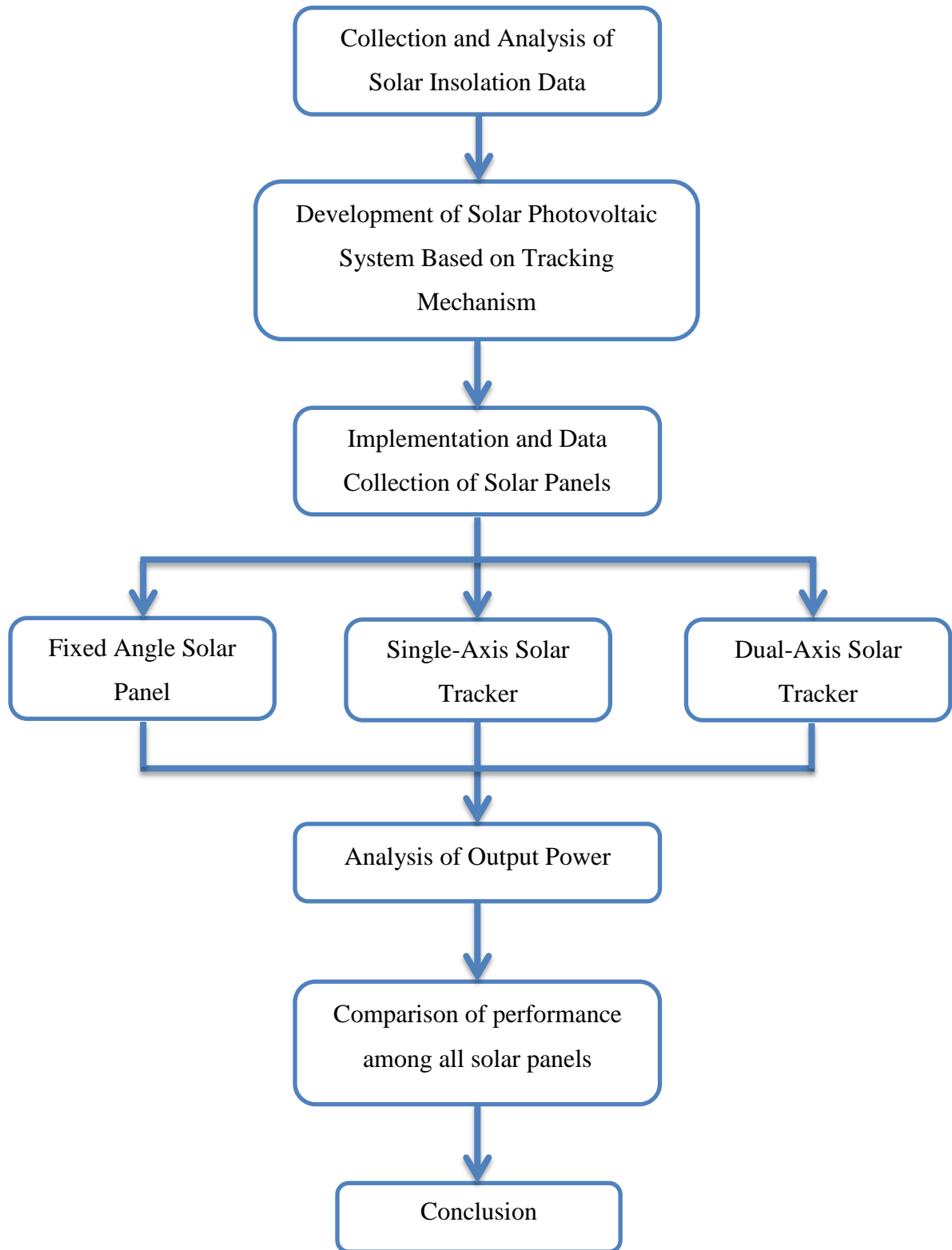

Figure 19: Experiment Process Flow

3.2.1 Solar Insolation Data Collection

The solar insolation data has been recorded for few days to get the best data average. This solar insolation data is required to know the average daily sun hour. The data of solar insolation is recorded from 7 a.m. to 7 p.m. at Universiti Teknologi Petronas Solar Field Testing Facility. Using the Data Taker, the solar insolation data are logged and saved. The data can be retrieved from the Data Taker web interface in the desired range, for example from 7 a.m. to 7 p.m. Data Taker also enable the data monitoring which can be viewed in the form of mimic meter and trend graph. From the data collected, the sun hour per day is determined and being used to calculate the sizing of the solar power system. The data tabulation and graph plotted is shown in the Result section and the solar insolation data are further discussed in the Discussion section. Below are the pictures taken around the Solar Field Testing Facility during the data taking process.



Figure 20: Solar Field Testing Facility



Figure 21: Solar Radiation Sensor



Figure 22: Data Taker

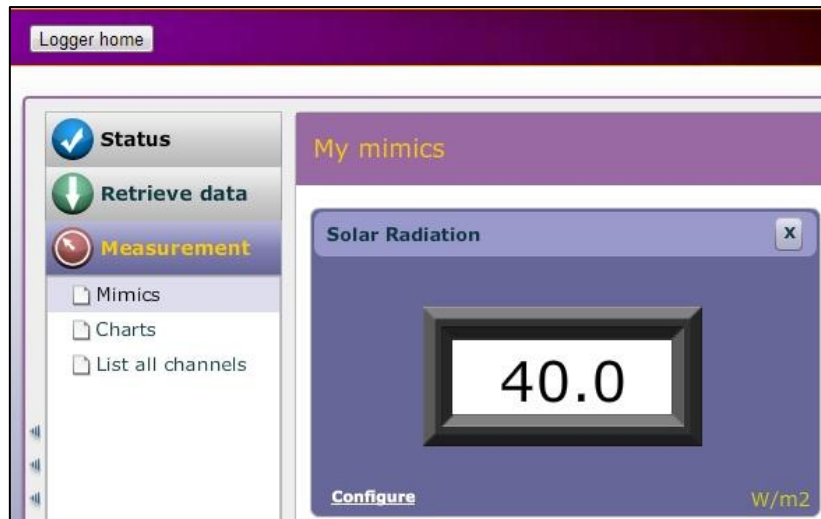

Figure 23: Mimic Digital Meter for Monitoring

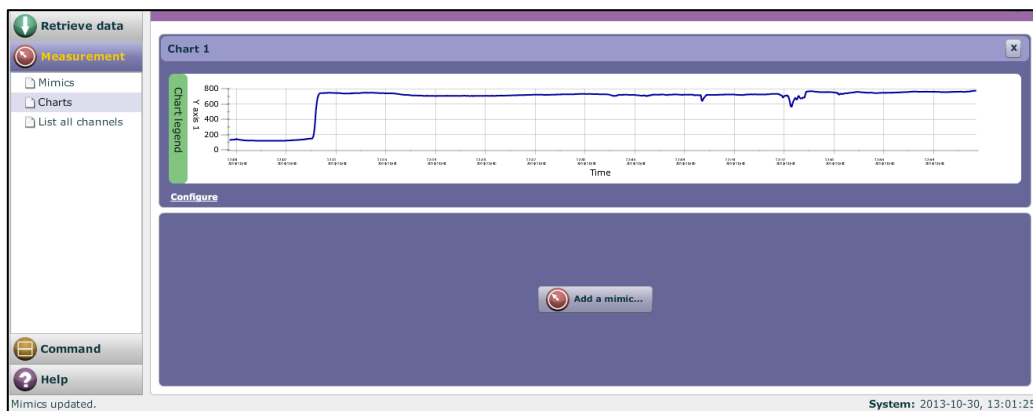

Figure 24: Trend Chart for Monitoring

3.2.2 Sizing of Solar Photovoltaic System

Sizing is an important process in optimizing the solar energy system. The first step in designing a solar PV system is to find out the total power and energy consumption of all loads that need to be supplied by the solar PV system. This value of power consumption in watt hour can be used to calculate the total watt-peak rating and number of solar panel needed. The inverter also needs to be sized properly where the input rating should not be lower than the total watt of the appliances. The voltage rating of the inverter should be the same as the voltage of the battery. The Amp-hour of the battery need to be calculated rightly to ensure power supplies when there is no power produced by PV modules. Table 2 below are the summary of sizing calculation for solar modules, battery and inverter.

Summary	Equation	Calculated Value
Power Consumption Demand	$(AC\ Load + DC\ Load) * 24$ Hours	$4\ Watts \times 24\ Hours =$ 96 Watt Hour (Wh)
Ampere	Rated Power / Rated Voltage	$3\ W / 6\ V = 0.5\ Amps$
Usable Module Output	Amps \times Battery Voltage	$0.5\ Amps \times 12\ Volt =$ 6 W
The average sun hour per day is calculated from pervious section	From Data Collection	4.28 hour/day \approx 4.3 hours/day
Average Daily Usable Module Output	Usable Module Output \times Sun Hour	$6\ W \times 4.3\ Hours =$ 25.8 Wh
Number of Modules Needed	Power Consumption Demand / Average Daily Usable Module Output	$96\ W / 25.8\ Wh$ $= 3.72 \approx 4$ modules
Inverter sizing	Total AC loads (watt) + Total DC loads (watt)	4 Watt
Inverter Voltlage	Inverter voltage = Battery voltage	12 Volt

Table 2 : Table of Sizing Calculation Summary

In this small-scale solar power system, four small size of solar panel rated at 3 watt and 6 volt are selected as representation of a bigger solar power system in the real application. With this rating, the load that suit with the size of solar panels available is estimated.

3.2.3 Design of Tracker's Frame

The design of the solar panel mounting is designed according to the optimum parameters developed from the literature review made. In the earlier stage, it is decided that the solar panel mounting will have different characteristic. The tracking mechanism for the three of the panels have been calculated and implemented to the mounting design. The early stage design and improved design has been illustrated using the Sketch Up software and the constructions of the three solar panels mountings are almost complete.

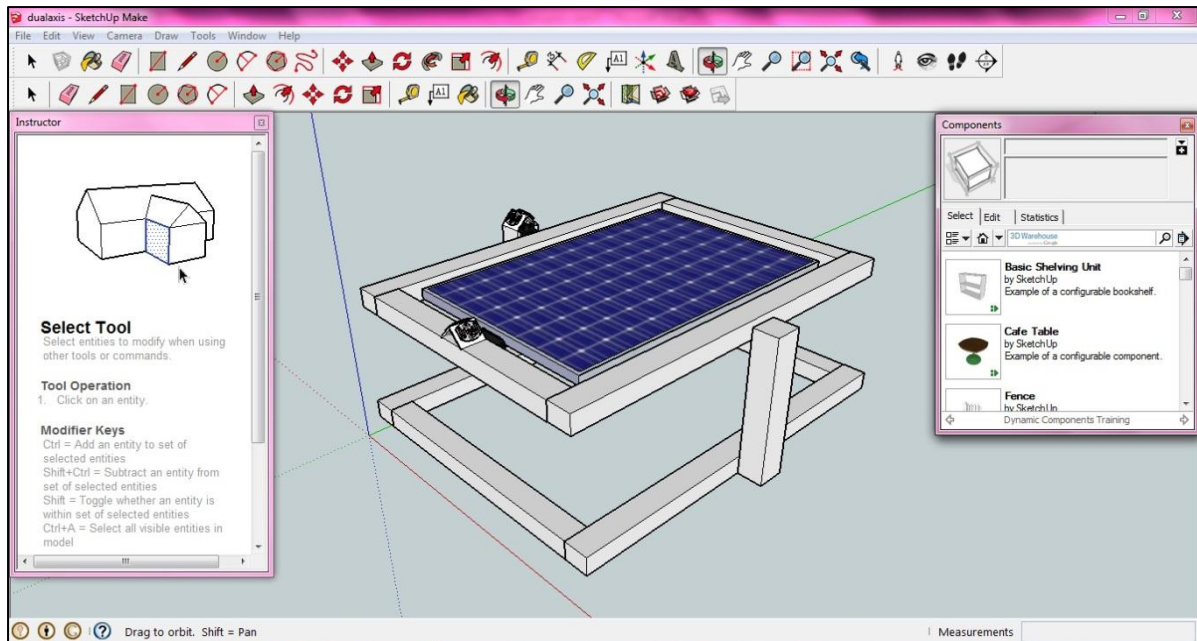

Figure 25: Mounting and Tracker 3D Drawing Design using Sketch Up software

Beside the mounting design and fabrication work, the sensor position together with its circuit connected to the servo and servo driver are determined to ensure the tracking mechanism work correctly. Based on the literature review made, the best sensor position is selected which is suitable with the design of the small scale solar panel tracking mechanism. The experiment is also done to prove the best sensor position as explain in Result & Discussion section. The circuit main components are the light dependent resistor (LDR), servo driver and the servo mounted to the frame of the trackers. Figure 27 shows the schematic diagram of the sensor circuit including all the components.

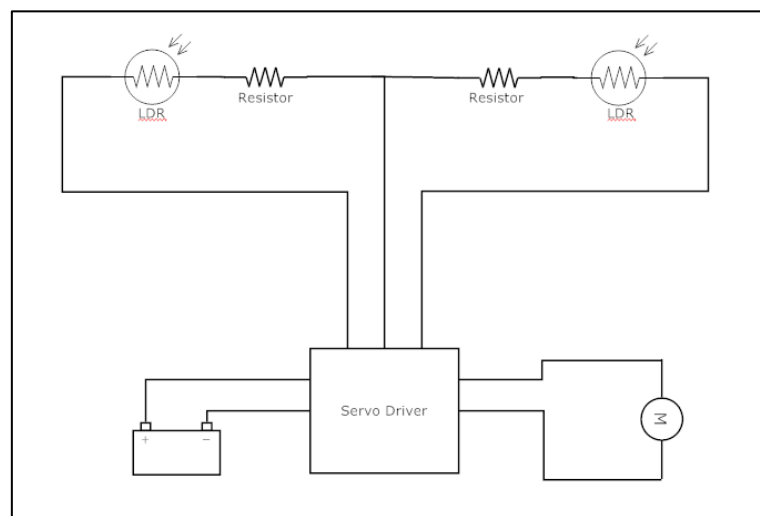

Figure 26: Schematic Diagram of Sensor Circuit

3.3 Tools and Software

With the availability of specific lab and testing facilities for solar system development, the data taking process and experiment can be run smoothly. Some of the tools are already available in laboratory and some need to be bought from the electronics related shop available around Ipoh. Throughout the process of data taking, designing and fabricating, both hard and software tools are utilised. The software used in this project can be purchased and downloaded from the internet. Sketch Up and Smart Draw allows the user to freely download and can be used during the free trial period which is enough for basic drawing in this project. Table 3 below are the summary of materials, tools and software used which is categorized in different scope of work. However,

Solar Insolation Data	
Hardware	Software
<ul style="list-style-type: none"> • Data Taker set • Solar insolation sensor • Tripod 	<ul style="list-style-type: none"> • Data Taker web-interface for data monitoring and retrieving
Design & Fabrication	
Hardware	Software
<ul style="list-style-type: none"> • 3 solar panels with 3W 6V rating • Mechanical machineries in mechanical lab • Aluminium plate • Screw & Nut • Drill • Protractor & compass • Servo • Servo driver 	<ul style="list-style-type: none"> • Sketch Up • Smart Draw
Solar Tracker & Data Taking Process	
Hardware	Software
<ul style="list-style-type: none"> • Data Taker • Pasco Current Sensor • Pasco Data Logger • Servo driver • Wires • Crocodile clipper • Cable tie 	<ul style="list-style-type: none"> • Data Taker • Data Studio

Table 3: List of Software & Hardware Used

3.4 Gant Chart of FYP I

Project Flow / Week	1	2	3	4	5	6	7	8	9	10	11	12	13	14
Selection of project title	Active													
Preliminary Research Work and Literature Review		Active	Active	Active	Active									
Submission of Extended Proposal Defence						Active								
Preparation for Oral Proposal Defence							Active	Active						
Oral Proposal Defence Presentation									Active					
Detailed Literature Review								Active	Active	Active	Active	Active		
Preparation of Interim Report			Active	Active	Active	Active	Active	Active	Active	Active	Active	Active		
Submission of Interim Draft Report													Active	
Submission of Interim Final Report														Active

3.5 Key Milestone of FYP II

Project Flow / Week	1	2	3	4	5	6	7	8	9	10	11	12	13	14	15
Sun insolation data at Pocket D	●														
Sizing of four solar PV system	✓	●													
Lab experiment for sun tracker		✓	●												
Lab experiment for sensor position			✓	✓	●										
Finishing of four sun tracker prototypes					✓	✓	●								
Progress report		✓	✓	✓	✓	✓	✓	●							
Outdoor experiment							✓	✓	✓	●					
Voltage, current and output power graph studies and comparison							✓	✓	✓	●					
Poster presentation										✓	●				
Submission of draft report											✓	●			
Submission of final dissertation (softbound)											✓	✓	●		
Submission of technical paper												✓	●		
Oral Presentation													✓	●	
Submission of final dissertation (hardbound)															●

Chapter 4: Results & Discussion

4.1 Solar Insolation Data

As discussed in Chapter 3, the solar insolation data are taken in 2nd November 2013 with the weather cloudy the whole day and no rain from period 7 a.m. to 7 p.m. to calculate the average daily sun hour. The method of data taking is stated clearly in the Project Activities Section. The data are then retrieved and analysed as summarized in the Table 4 below. The graph is plotted to show the trend on how solar irradiance increased and decreased throughout the day.

Time	Average W/m ² /hour
7.00 - 8.00	30.9802
8.00 - 9.00	93.2608
9.00 - 10.00	221.8053
10.00 - 11.00	538.9889
11.00 - 12.00	667.0619
12.00 - 13.00	712.4719
13.00 - 14.00	517.8383
14.00 - 15.00	405.1090
15.00 - 16.00	345.6593
16.00 - 17.00	520.8905
17.00 - 18.00	187.5860
18.00 - 19.00	42.4150
Total W/m²/day	4284.0671
Wh/m²	4.2800

Table 4: Hourly Solar Insolation Data

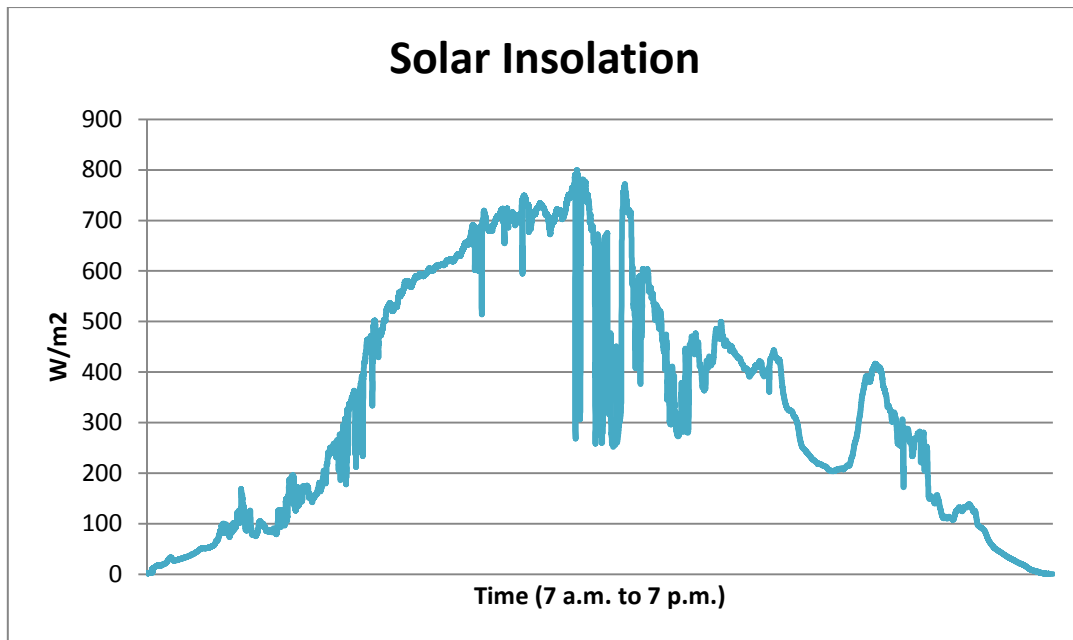

Figure 27: Graph of Hourly Solar Insolation

The graph of data recorded is plotted as shown in Figure 28. The result shows that the solar insolation increases exponentially from 7 a.m. to 11 a.m. with the reading from $30.98 W/m^2$ to $538.99 W/m^2$. The reading is then continue to increase to $712.47 W/m^2$ which is the peak of the day at time 12 noon to 1 p.m. The solar insolation is then decrease gradually from 1 p.m. to 4 p.m. before it increased again at 4 p.m. to 5 p.m. The decreasing value of solar insolation from 1 p.m. to 4 p.m. is because of the shades from cloudy condition on that particular range of time. The solar insolation reading dropped from $187.59 W/m^2$ to $42.42 W/m^2$ significantly when it reached the time 6 p.m. to 7 p.m.

The complete reading of hourly solar insolation data enable us to calculate the average sun hour per day. The calculated sun hour is $4.28 kWh/m^2$, which means that the Solar Field Testing Facility area received 4.28 hours of sun per day at $1kW/m^2$. The average sun hour can be varies differently from day to day throughout the year since weather condition changes differently from hot to rainy and cloudy.

As we know that the sun hour changes from time to time, the solar insolation data need to be taken again when the experimental work is done in the future. To ensure the result of the solar panel efficiency is right, the output power from the panel need to be compared with the solar insolation value of that particular day when the experiment is run.

4.2 Design & Fabrication

The design of the three solar panels mountings and trackers are first being illustrated using Sketch Up software. This software can be used to draw a 3D image where we can decide how our prototype precision will look like in real. The 3D drawing of all the solar panels mountings and trackers can be seen in the Figure 29 to Figure 38 provided below.

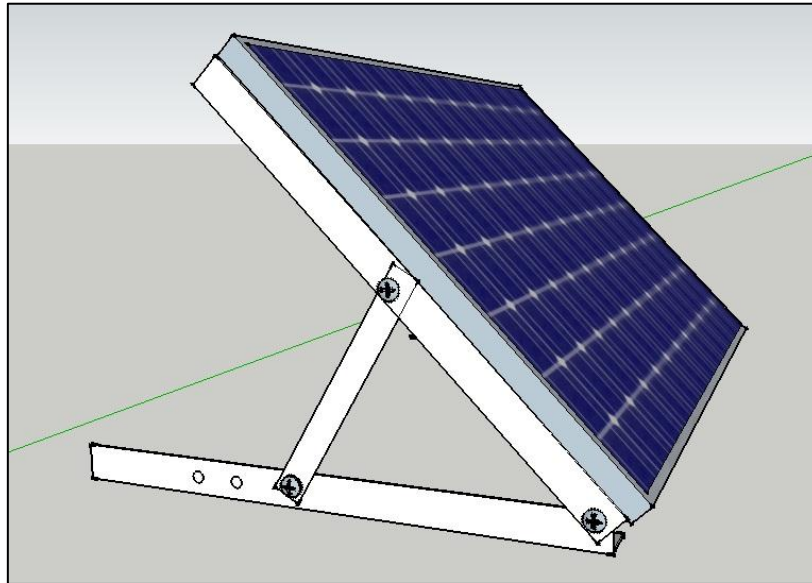

Figure 28: Fixed Angled Solar Panel 3D drawing from the left side

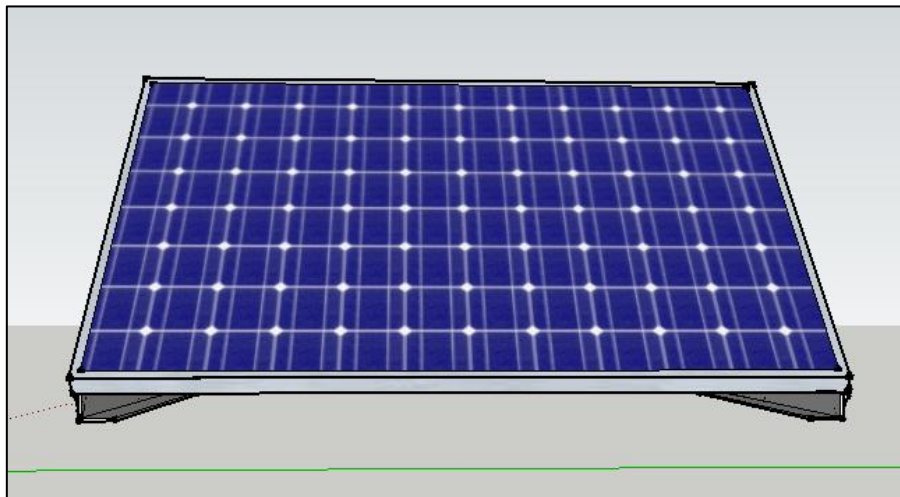

Figure 29: Fixed Angled Solar Panel 3D Drawing from the front

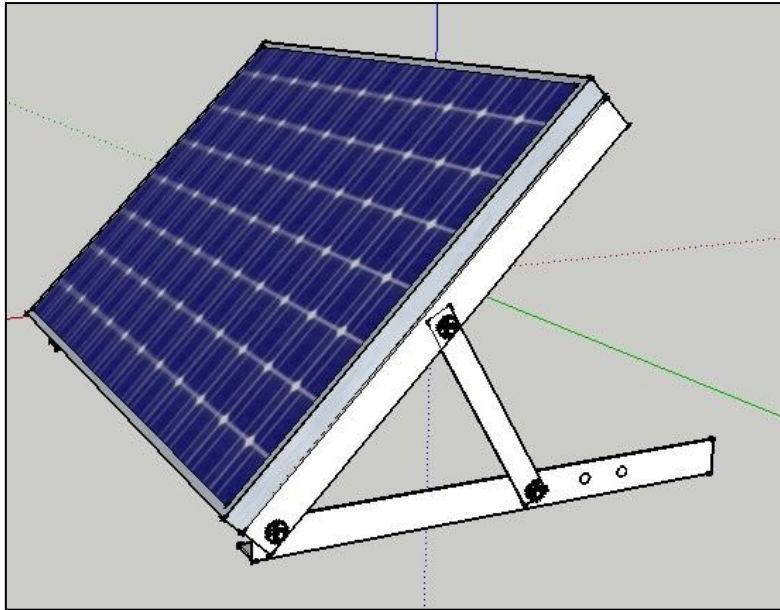

Figure 30: Fixed Angled Solar Panel 3D drawing from right side

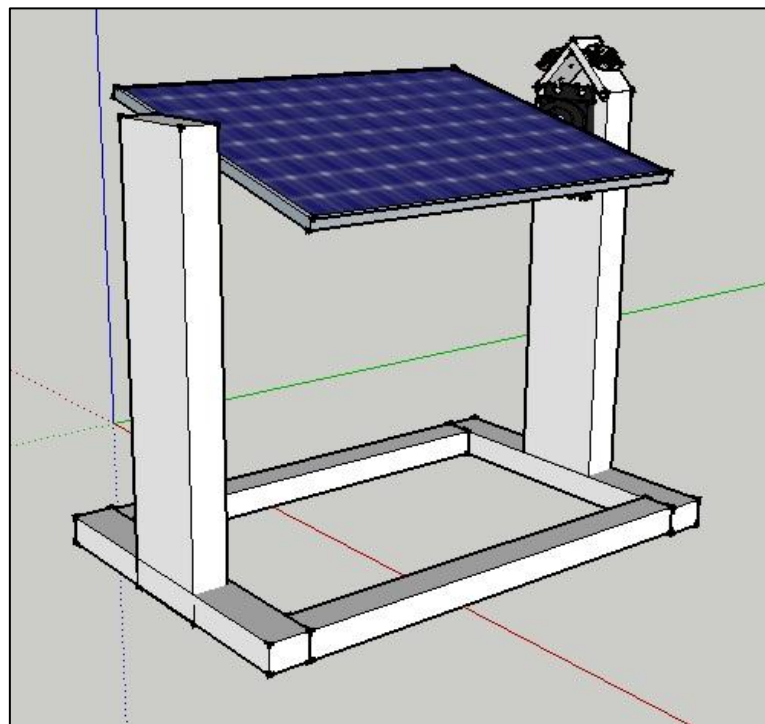

Figure 31: Single Axis Solar Panel 3D drawing from left side

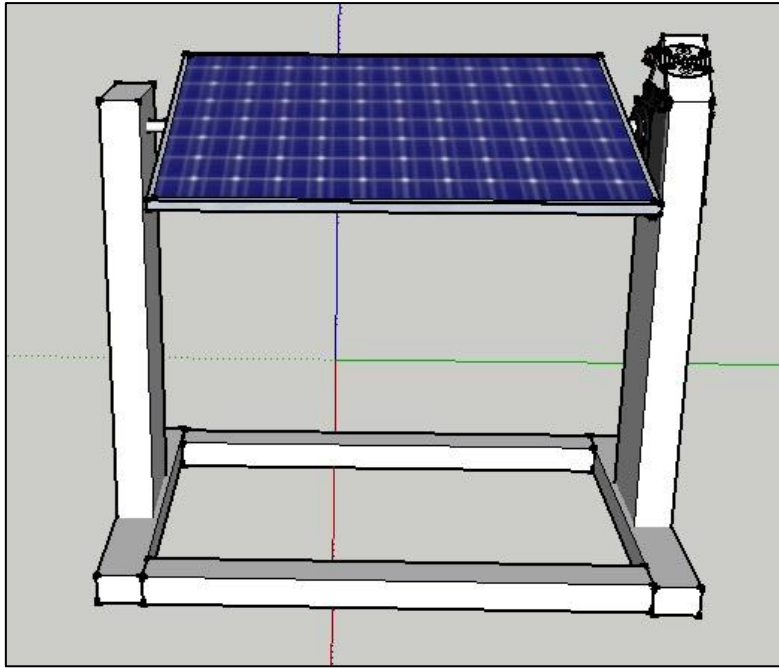

Figure 32: Single Axis 3D drawing from the front

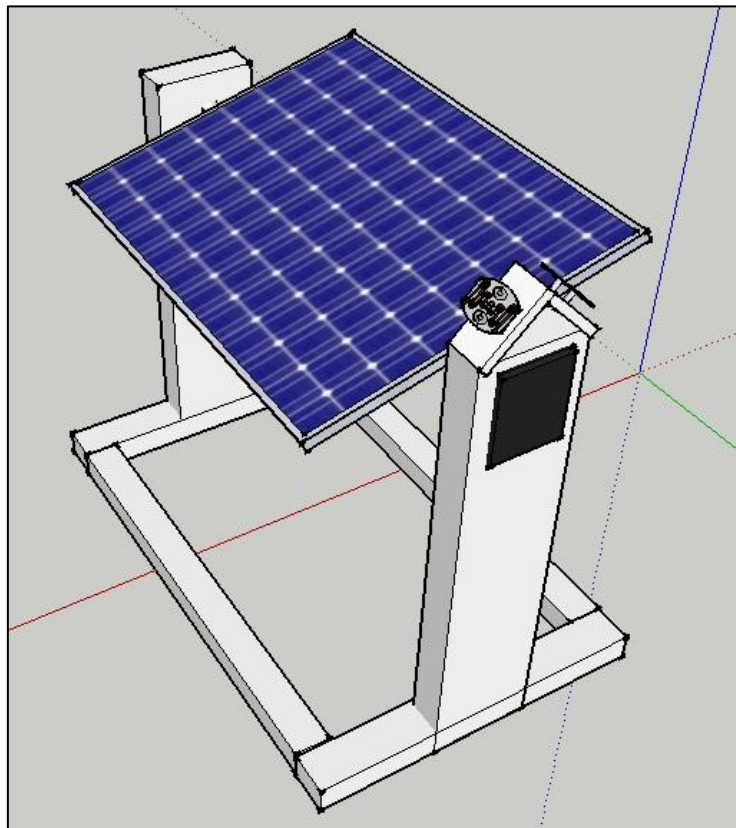

Figure 33: Single Axis Solar Panel 3D drawing from right side

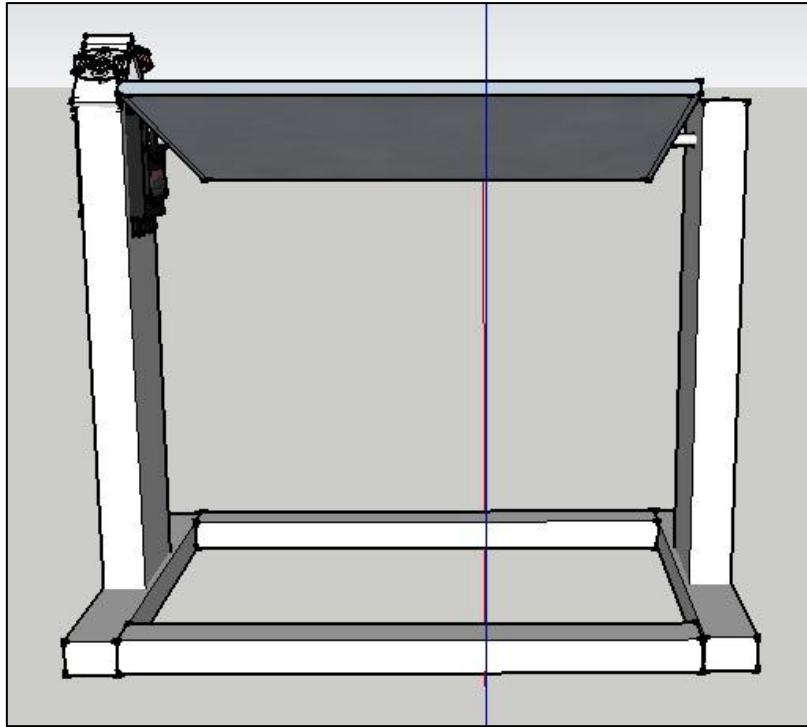

Figure 34: Single Axis Solar Panel 3D drawing from back side

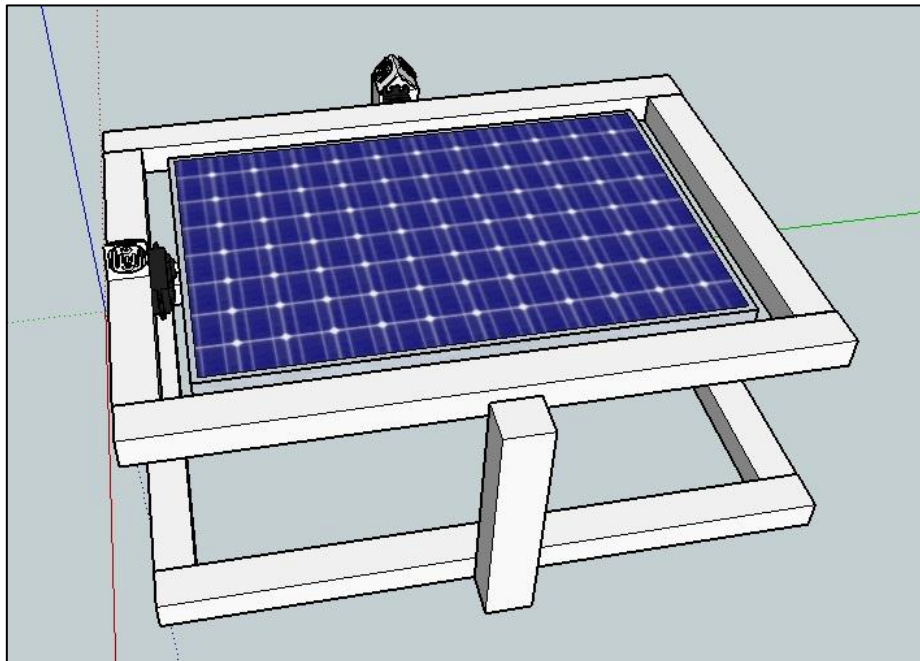

Figure 35: Dual Axis Solar Panel 3D drawing from left side

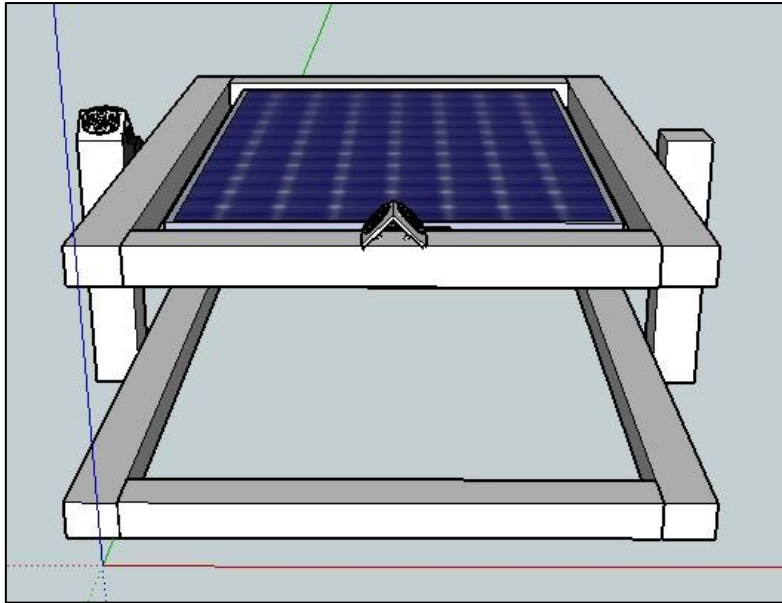

Figure 36: Dual Axis Solar Panel 3D drawing from right side

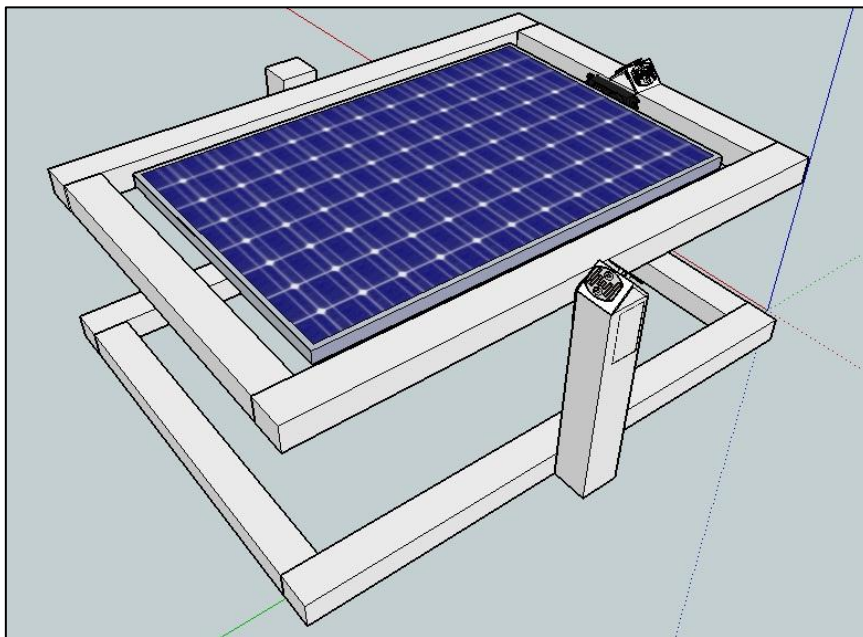

Figure 37: Dual Axis Solar Panel 3D drawing from right side

The process of fabrication started as the design for all the mounting and trackers are determined accurately such as the size, dimension and material used. The prototypes are fabricated in the mechanical lab where all the tools needed are available. From the fabrication

process experiences, some of the fabrication parts need to be repeated to do the correction and improve the design.

4.3 Sensor Position

In this trackers design process, the main important part is the design of sensor position. Different sensor position will give different turnout to the trackers' movement toward the sunlight. An experiment in the Figure 39 is made to determine a better sensor position for the tracker by manipulating different sensor holder.

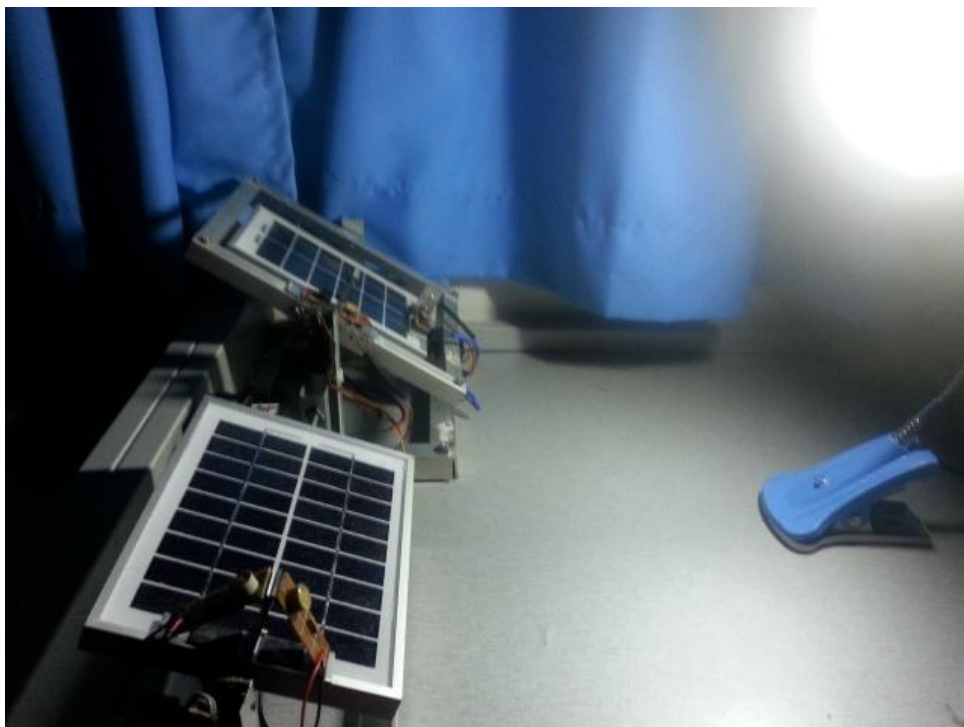

Figure 38: Experiment on Sensor Position

This experiment is done in a dark room with table lamp act as the sunlight simulator. Table lamp is used as it gives light on certain angle to the tracker so the trackers move until the servo stop and hold the position. Both trackers are set to be single axis tracker. Only one axis of both trackers is connected to the batteries. Both trackers are attached with two different type of sensor holder to give different sensor position. Figure 40 and 41 below shows different sensor holders attached to both trackers.

When the table lamp is on, both trackers move and face toward the light. The tracker with the 'inverted T' shape sensor holder face the light better than the 'triangle' shape sensor holder.

This is because the left sensor is still receiving some light from the table lamp. The 'inverted T' sensor holder are better as the aluminium plate provides shade on the left sensor hence the right sensor giving more input and move the servo toward the light better. This Figure 40 and 41 attached below show clearly regarding the explanation above.

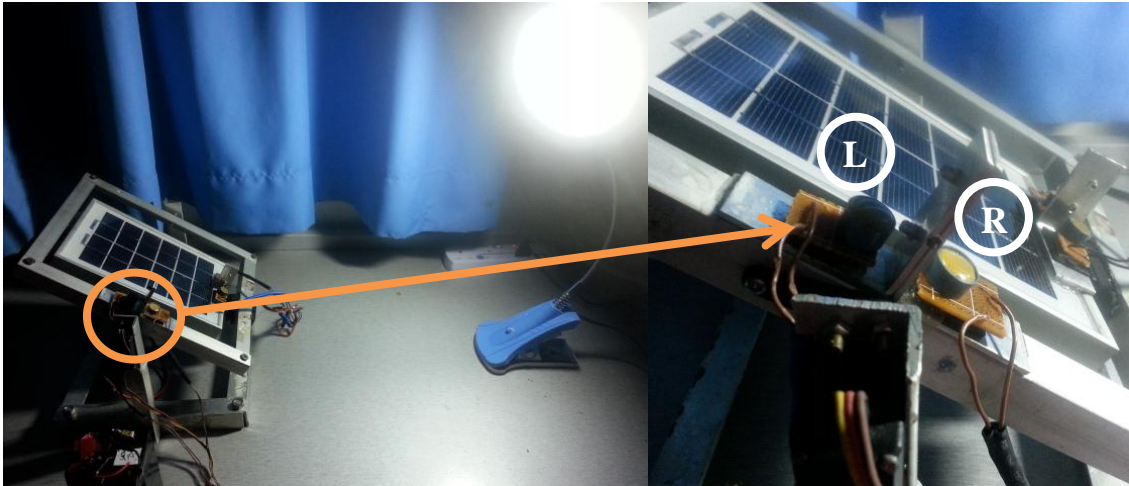

Figure 39: 'Inverted T' shape Sensor Holder

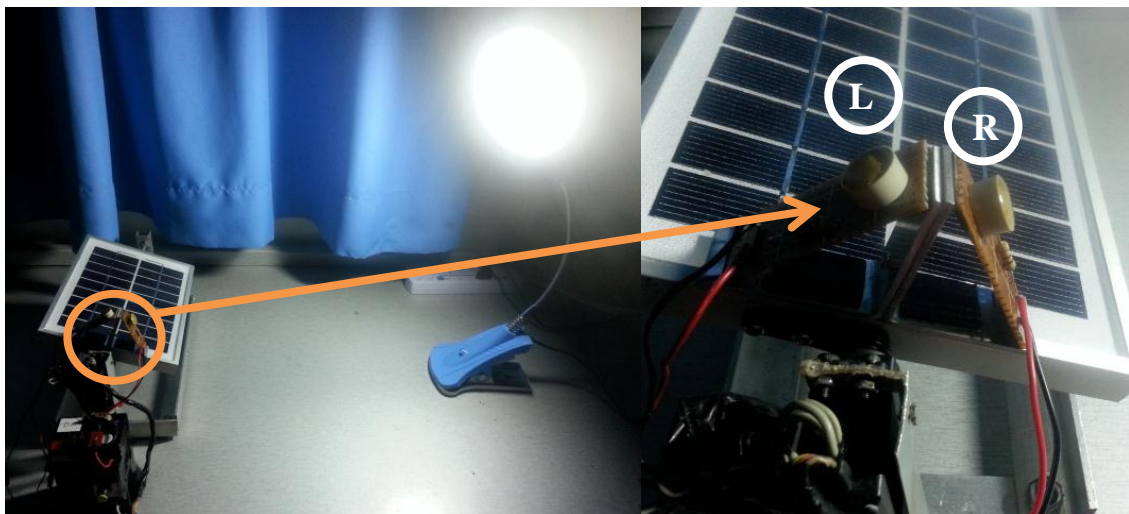

Figure 40: 'Triangle' shape Sensor Holder

4.4 Output from Solar Panels

A number of experiments are conducted to collect the output data from all solar panels with three different tracking mechanisms. The three important values taken are the solar insolation data on that day (22nd December 2013), the output voltage of the three solar panel from 9 a.m. to 6 p.m. The three solar panels (single axis, dual axis and fixed angle solar panels) are

located near to each other to ensure that they received same amount of solar radiation as shown in Figure 42.

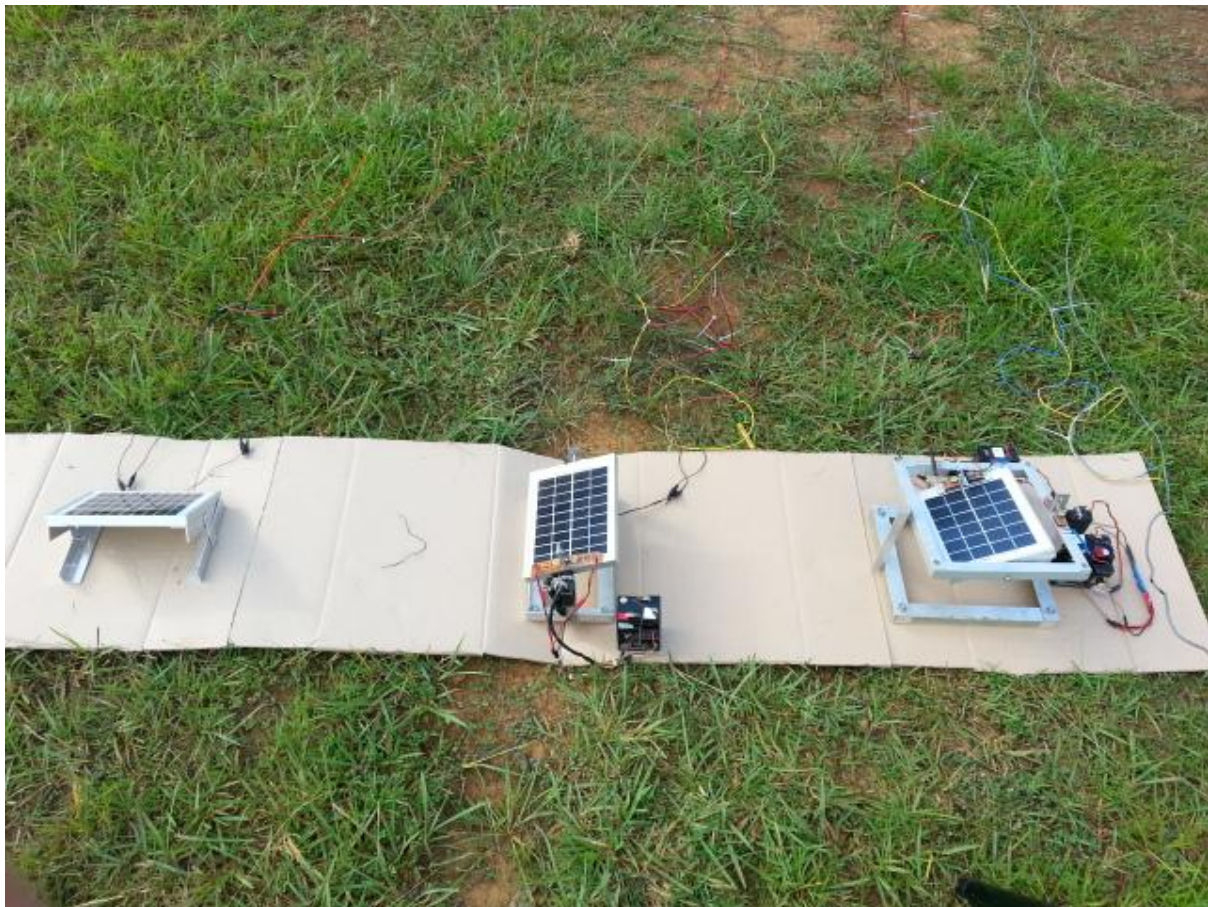

Figure 41: Location of Three Solar Panels

The voltage values are logged using Data Taker where the value reading are monitored and retrieved from the Data Taker web interface. Figure 43 show the web interface with data monitoring from all the solar panels. The short circuit current values are taken using the current sensor from Pasco and the software Data Studio to monitor and retrieve current value. Figure 44 shows the table of data and the graph of the short circuit current of all solar panel from Data Studio software.

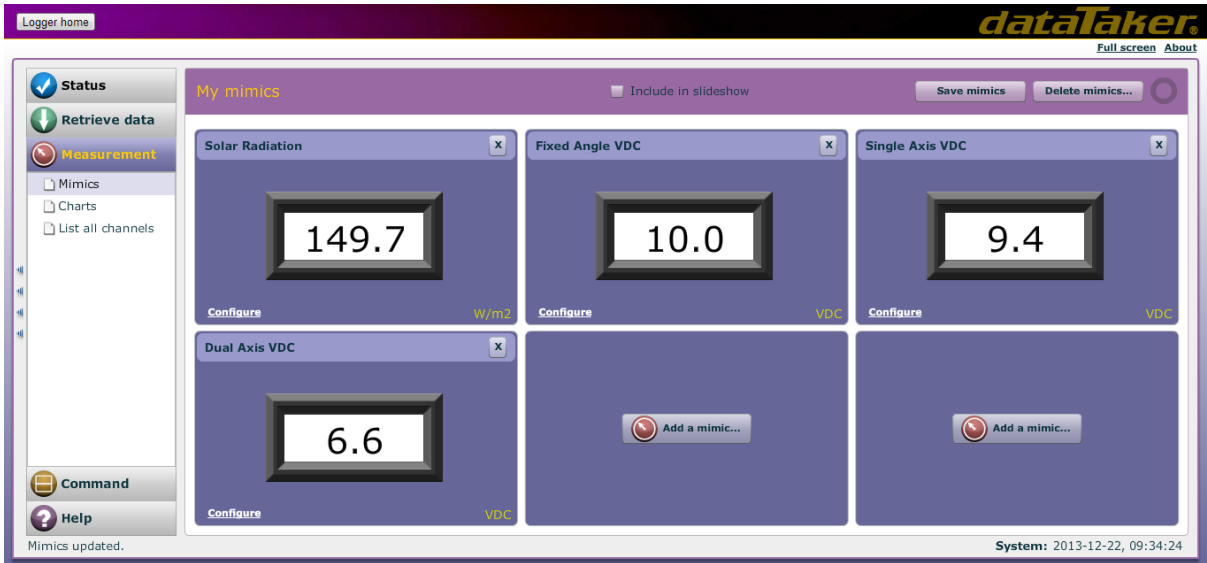

Figure 42: Data Taker Web Interface

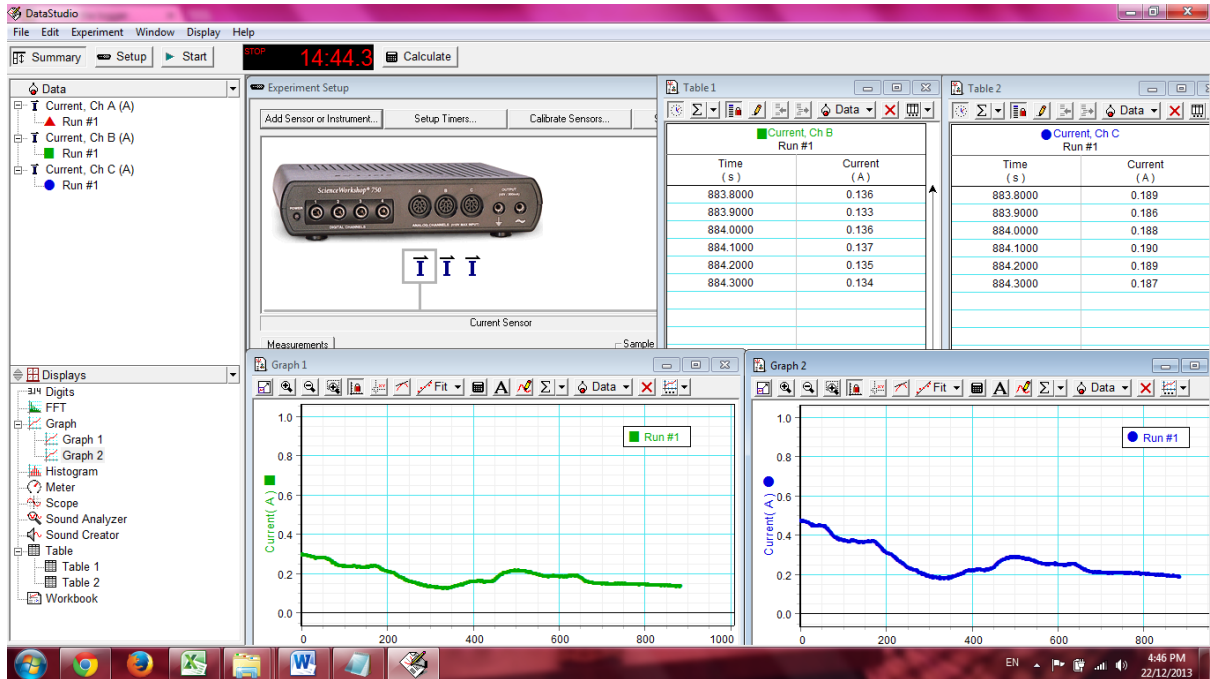

Figure 43: Data Studio software



Figure 44: Data Taker and Pasco Current Sensor



Figure 45: Pasco Data Logger and Laptop for Data Monitoring

The graph of solar insolation in Figure 47 is plotted to show the amount of solar radiation on 22 December 2013 for nine hours. The solar radiation measured in W/m^2 was fluctuating and

reached the maximum value of nearly 900 W/m^2 when approaching 1 p.m. The fluctuating value is caused by shade from the cloud moving on the sky hence prevent direct sunlight to reach on the solar panels. This solar radiation data is also used to compare the output voltage and short circuit current graph that will be discussed in next paragraph.

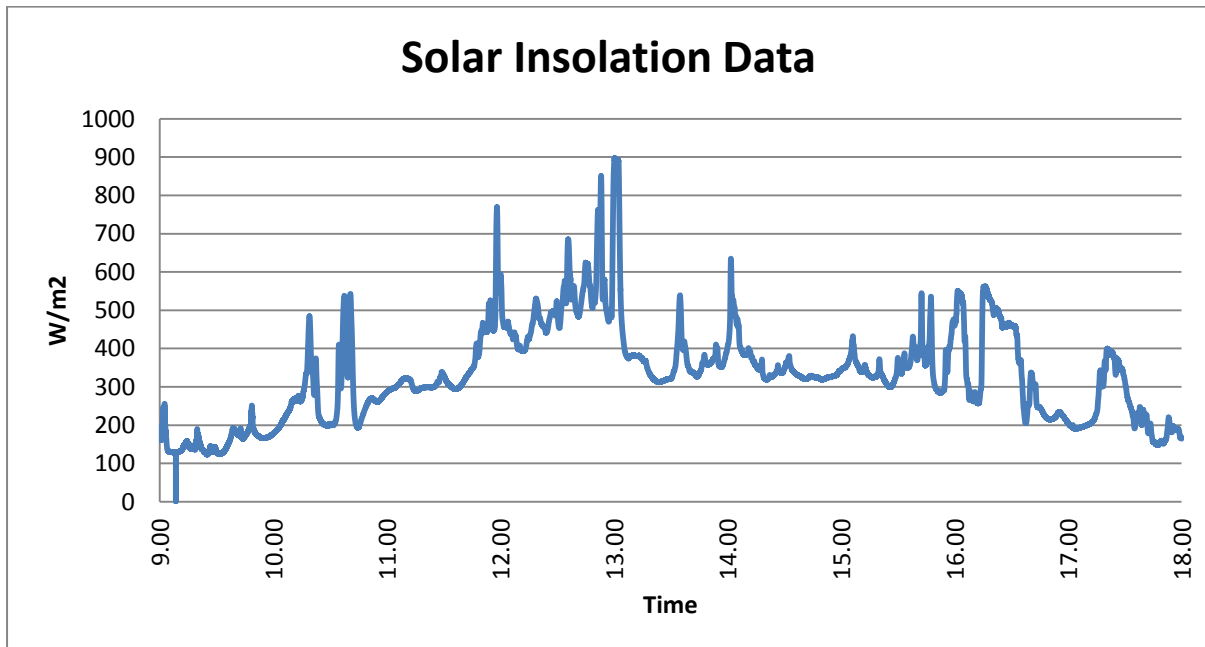

Figure 46: Solar Insolation Data

Output voltages from the solar panels are logged using Data Taker throughout the day. The graph of output voltage from three different panels are plotted in Figure 48, 49 and 50. In overall, the voltage produced by the dual axis solar tracker is higher almost all the time as compared to the other two trackers. During the starting of the experiment, the fixed angle solar panel reached 5.15 V, the single axis solar tracker reached around 5.40 V and dual axis solar tracker reached to 5.56 V at 9 a.m. The values continue to goes up and down throughout the day depending on the fluctuation of solar irradiance intensity that changes with the appearance and disappearance of cloud shades. From the graph, the voltage values are fluctuating in different range from all the panels. The fixed angle solar panel output voltage ranging from 5.1 V to 5.6 V, single axis tracker output voltage ranging from 5.3 V to 5.7 V, dual axis tracker output voltage ranging from 5.55 V to 5.85 V.

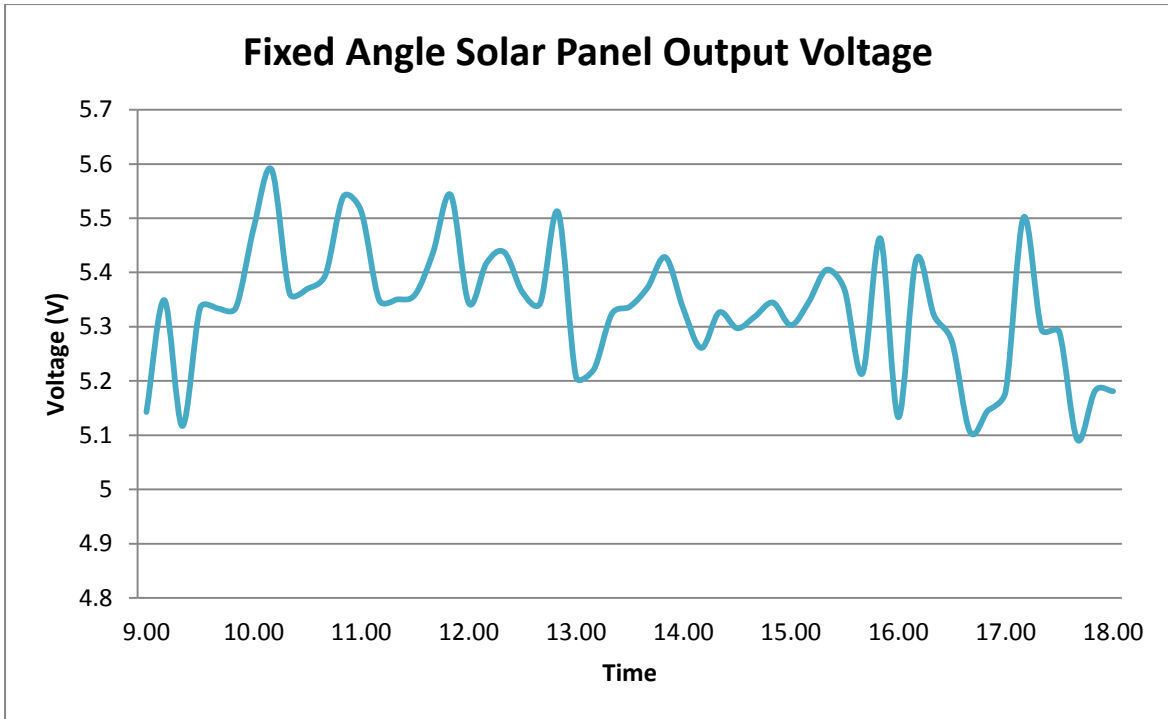

Figure 47: Voltage from Fixed Angle Solar Panel

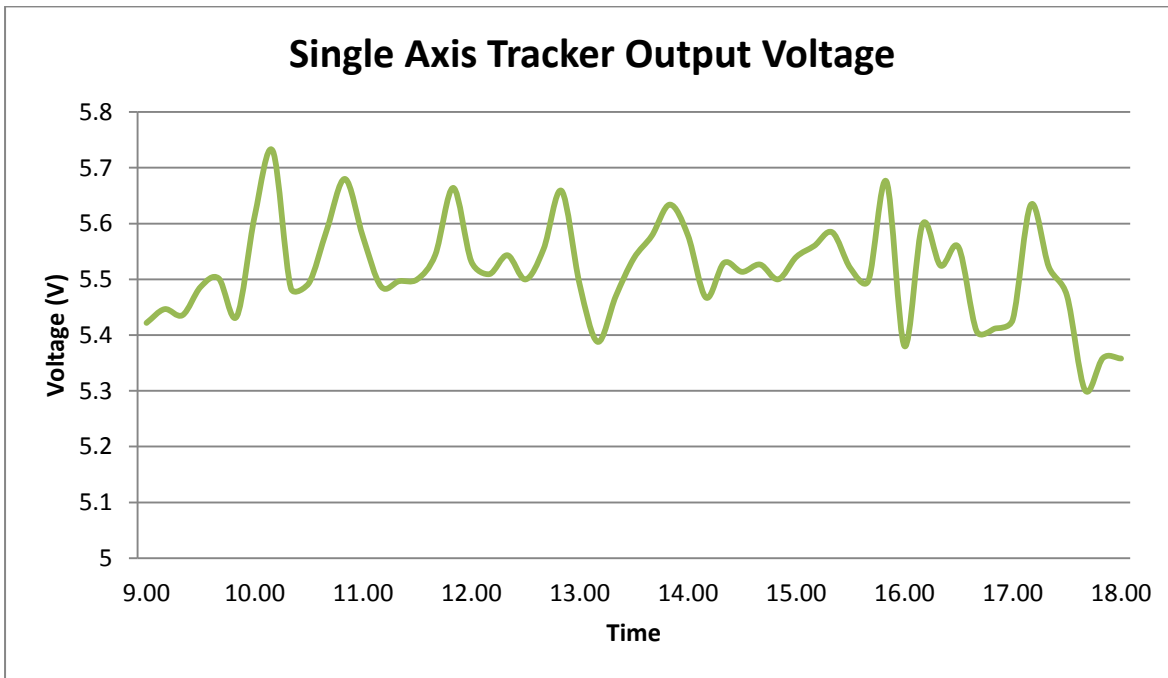

Figure 48: Voltage from Single Axis Solar Panel

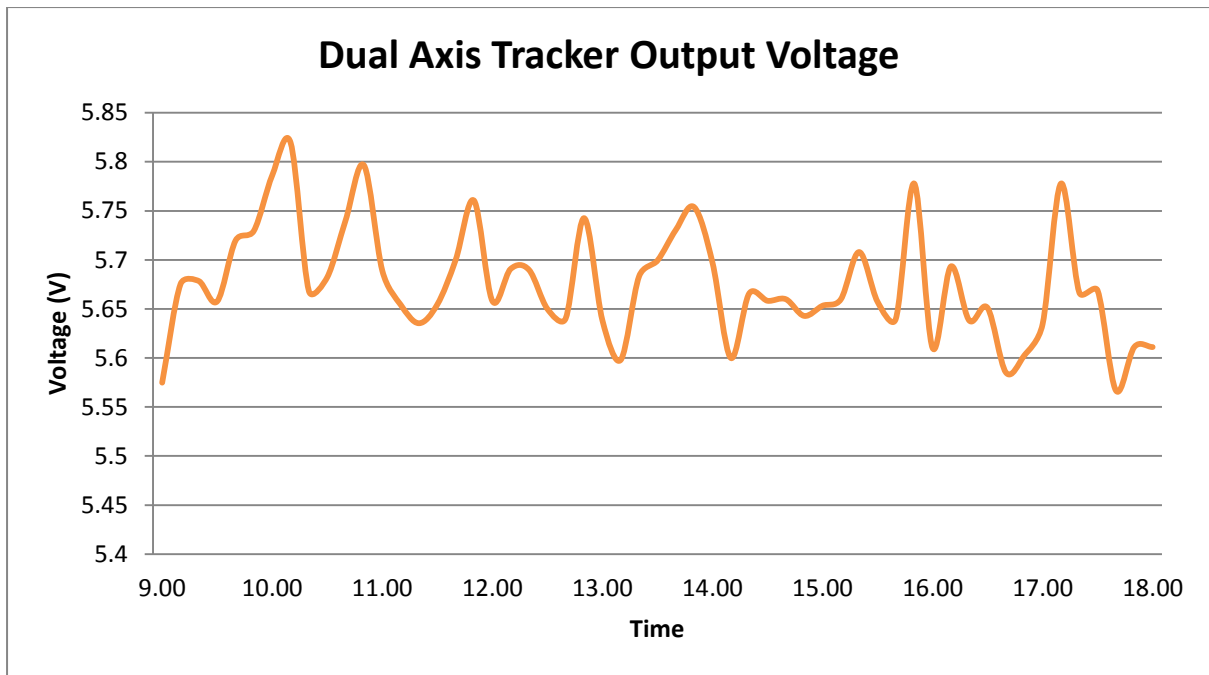

Figure 49: Voltage from Dual Axis Solar Tracker

Figure 51, 52 and 53 shows the graph of short circuit current generated from all three panels. The current value measured shows increasing and decreasing pattern according to the intensity of light at certain time. As the light intensity become high, the short circuit current value increase immediately by all the panels. However the values are the different as the dual axis produce the highest among all panels and fixed angle solar panel generated the lowest current value. From the observation, the difference in the current value from all the panels is big during the early morning and during the late evening. However the difference in current value between all the panels is smaller during the noon or peak sun hour where the sun position is very high. This happen because the solar trackers' angle of incidence are about the same to the fixed angle solar panel. The fixed angle solar panel does not face the sun directly during the morning and late evening while the tracker face the sun better at this time. In overall, the dual axis solar tracker generated the highest short circuit current value compared to the other two panels.

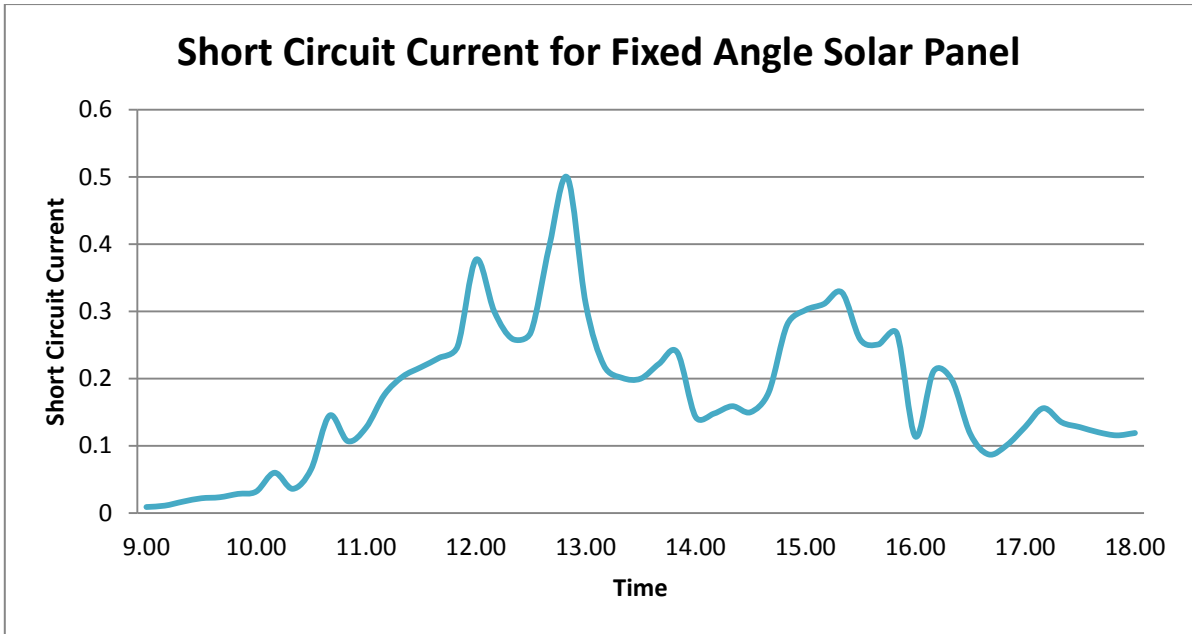

Figure 50: Short Circuit Current from Fixed Angle Solar Panel

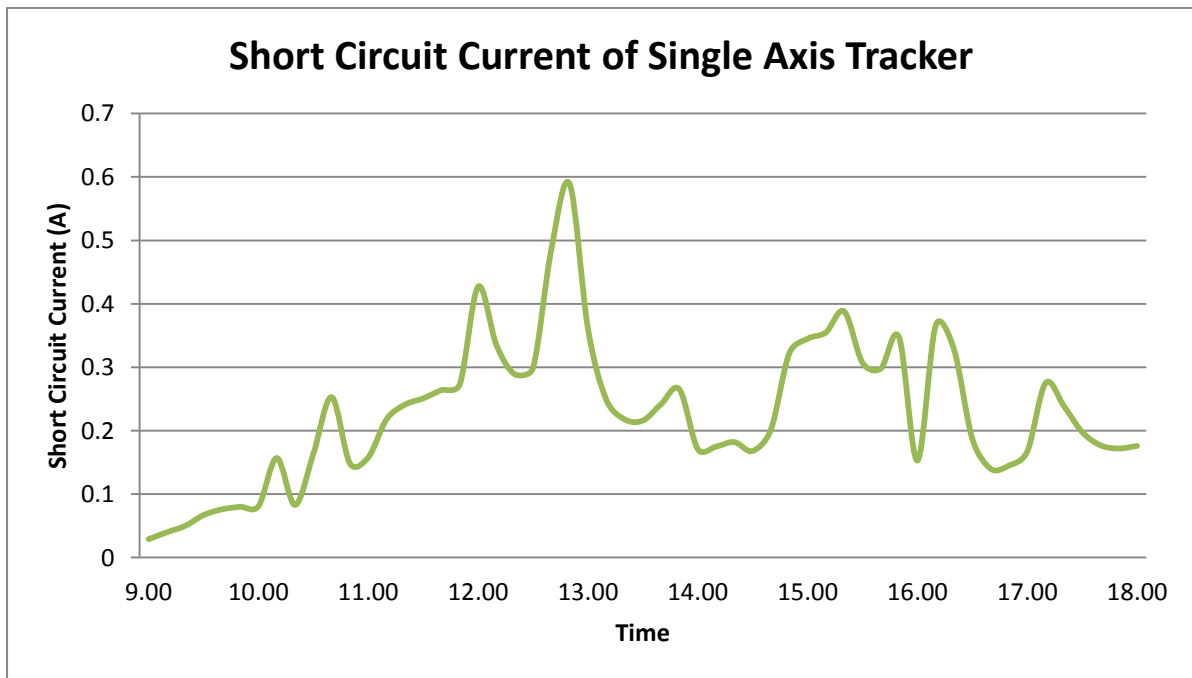

Figure 51: Short Cuircuit Current from Single Axis Solar Panel

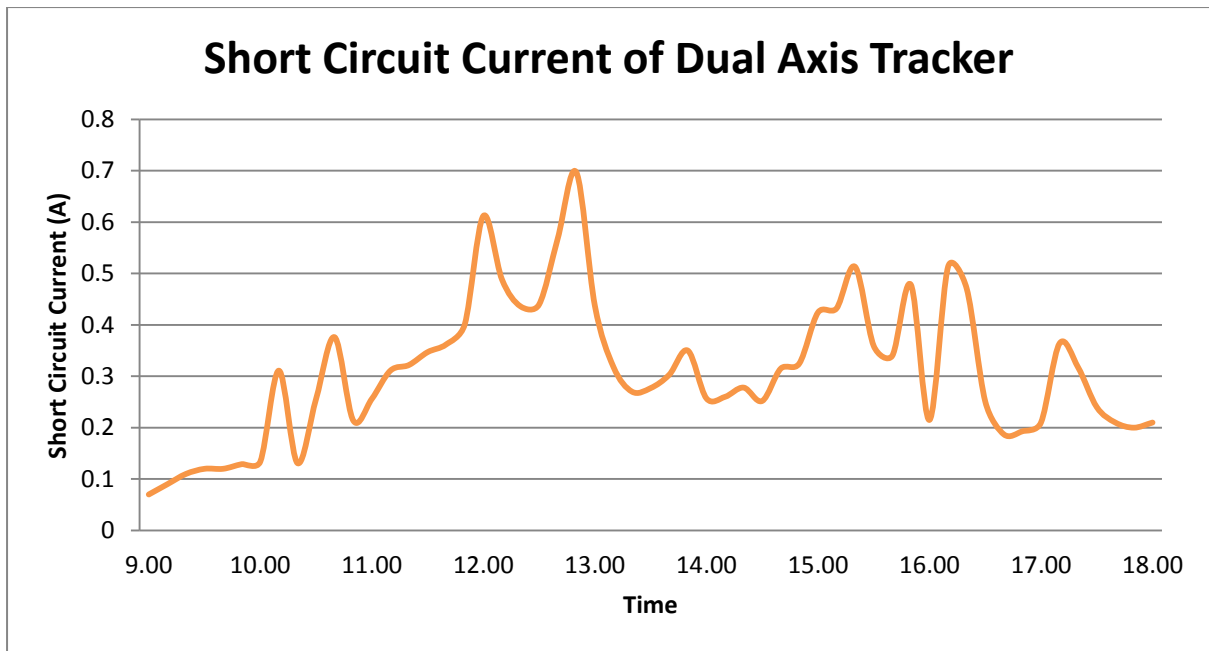

Figure 52: Short Circuit Current From Dual Axis Tracker

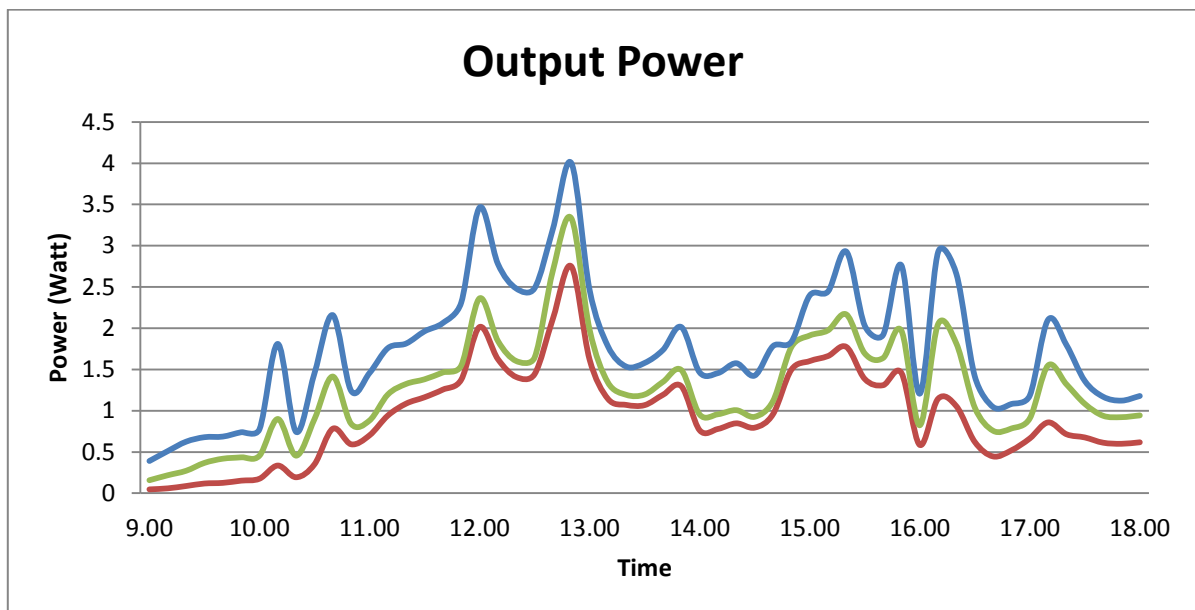

Figure 53: Output power produced by the three solar panels

The output power of all solar panels is calculated as the voltage and current are logged completely in one day. The output power is the multiplication of output voltage and short circuit current above. From the graph shown in Figure 54, the output power from dual axis tracker is the highest since the voltage and current generated also are the highest among all panels. The output power of the fixed angle solar panel are closed to the output power during

the afternoon. This is because the sun is very straight above and faces the fixed angle solar panel with the right angle.

Chapter 5: Conclusion

5.1 Solar Insolation Data

The solar insolation data varies according to season. The solar insolation data taken on 22nd December 2013 is relatively low as December is the month where Malaysia receives heavy rainfall and shaded with cloud almost every day. The average sun hour recorded on that day is 4.28 KWh/m² with the peak solar insolation data of 712.47 W/m² from 12 noon to 1 p.m.

5.2 Solar Tracker Design & Fabrication

The design and dimension of the trackers are already illustrated using the Sketch Up software as the first step. The design fabrication of all the prototype are further completed by improving the sensor position. The fixed angle solar panel is fabricated according to the optimum parameter studied in the literature review. Some process need to be repeated to ensure the right dimension is produced. The important part in fabricating the fixed angle solar panel is the angle option that can be customised by the user. In solar trackers improvement, the sensor is positioned according to the best result determined and the circuit to run the servo is already tested. Both single axis and dual axis trackers are working accordingly as the batteries are connected.

5.3 Sensor Position

The experiment done to both type of sensor holder shows that the 'inverted T' shape sensor holder is better in this tracking mechanism. The 'inverted T' shape sensor holder is then chosen to be installed to the trackers since it move the tracker to track the sun better. The aluminium plate of the 'inverted T' shape sensor holder provide shade to the sensor that less exposed to the light. Thus, the sensor that directly exposed to light gives higher input to the servo driver so the tracker faces the light better.

5.3 Output from Three Solar Panels

The output voltages of the dual axis solar tracker produced the highest while fixed angled solar panel is the lowest. The result of output voltage so far is as initially expected. Same goes to the short circuit current generated by the panels. The dual axis tracker which tracks the sun better generate the short circuit current higher than the other two panels. The range value fluctuates according to the intensity of sunlight at certain time for both current and voltage. In the present of sunlight, the voltage value from a panel goes up to above 5 V and fluctuating between small differences from 5V to 6V. The current values of a panel produced different pattern where the current value increasing and decreasing between a big differences. For example, the dual axis sort circuit current generated are fluctuating from 0 A to 0.7 A. The graph pattern in short circuit current looks the same as how the graph of solar insolation data is fluctuating throughout the day. The power outputs from all panels are then calculated by multiplying the voltage and current value logged. The output power generated by dual axis tracker shows the highest compared to single axis solar tracker and also fixed angle solar panel.

References

- [1] M. E. I. Hub. (2011). Available: <http://meih.st.gov.my/statistics>
- [2] T. F. o. E. i. Malaysia. (2012, The Future of Energy in Malaysia. Available: <http://www.kettha.gov.my/en/content/future-energy-malaysia>
- [3] U. S. E. I. Administration. *Country Analysis Briefs*. Available: <http://www.eia.gov/cabs/Malaysia/Full.html>
- [4] U. S. E. I. Agency, "Total Carbon Dioxide Emissions from the Consumption of Energy," 2011.
- [5] E. Ang, "Reducing Our Carbon Footprint," in *The Star Online*, ed, 2010.
- [6] "Najib renews pledge for a greener Malaysia," in *Borneo Post Online*, ed, 2013.
- [7] N. Amin, C. W. Lung, and K. Sopian, "A practical field study of various solar cells on their performance in Malaysia," *Renewable Energy*, vol. 34, pp. 1939-1946, 8// 2009.
- [8] M. S. Balbir Singh, "A Study of an Optimum Parabolic Trough Design for Possible Power Generation in Malaysia," 2004.
- [9] S. I. G. F.A. Dimas, M.S. Ans, "Preliminary Investigation into the use of Solar PV Systems for Residential Application in Bandar Sri Iskandar, Malaysia," *Journal of Applied Sciences*, vol. 11: 2012-2017., 2011.
- [10] M. Z. Hussin, M. H. A. Hamid, Z. M. Zain, and R. A. Rahman, "An evaluation data of solar irradiation and dry bulb temperature at Subang under Malaysian climate," in *Control and System Graduate Research Colloquium (ICSGRC). 2010 IEEE*, 2010, pp. 55-60.
- [11] U. S. E. I. Administration, "Monthly Electricity Statistic March 2013," 2013.
- [12] P. M. D. Economic Planning Unit, "The Malaysian Economy In Figure 2013," 2013.
- [13] F. Muhammad-Sukki, A. B. Munir, R. Ramirez-Iniguez, S. H. Abu-Bakar, S. H. Mohd Yasin, S. G. McMeekin, *et al.*, "Solar photovoltaic in Malaysia: The way forward," *Renewable and Sustainable Energy Reviews*, vol. 16, pp. 5232-5244, 9// 2012.
- [14] D. Vatansever, E. Siores, and T. Shah, *Alternative Resources for Renewable Energy: Piezoelectric and Photovoltaic Smart Structures*, 2012.
- [15] C.-W. W. Kok-Keong Chong, "General Formula for On-Axis Sun-Tracking System," 2010.
- [16] D. Appleyard. (2009, 28 June 2013). Solar Tracker : Facing the Sun. Available: <http://www.renewableenergyworld.com/rea/news/article/2009/06/solar-trackers-facing-the-sun>

- [17] "The simple geometry of sun, moon, and star paths," in *Notes From Noosphere*, ed, 2012.
- [18] A. W. William Surlles, Eszter Horanyi, Malinda Schaefer Zarske. (2009, 14 June). *Solar Angles and Tracking Systems*. Available: http://www.teachengineering.org/view_lesson.php?url=collection/cub_/lessons/cub_pveff/cub_pveff_lesson01.xml
- [19] A. M. I. Prashanthini Sunderan, Balbir Singh, Norani Muti Mohamed, "Optimum Tilt Angle and Orientation of Stand-Alone Photovoltaic Electricity Generation Systems for Rural Electrification," *Journal of Applied Sciences*, vol. 11, 2011.
- [20] N. Barsoum, "Fabrication of Dual-Axis Solar Tracker Controller Project," *Intelligent Control and Automation*, vol. 2, p. 12, 2011.
- [21] N. Mohammad and T. Karim, "Design and Implementation of Hybrid Automatic Solar-Tracking System," *Journal of Solar Energy Engineering*, vol. 135, pp. 011013-011013, 2012.