

**IMPLEMENTATION OF CONTROL ALGORITHMS IN
BALL MAGNETIC LEVITATION SYSTEM TO
IMPROVE SYSTEM PARAMETERS**

By

LOO HUI SHIONG

FINAL PROJECT REPORT

Submitted to the Department of Electrical & Electronic Engineering
in Partial Fulfillment of the Requirements
for the Degree
Bachelor of Engineering (Hons)
(Electrical & Electronic Engineering)

Universiti Teknologi PETRONAS

Bandar Seri Iskandar

31750 Tronoh

Perak Darul Ridzuan

© Copyright 2012

by

Loo Hui Shiong, 2012

CERTIFICATION OF APPROVAL

IMPLEMENTATION OF CONTROL ALGORITHMS IN BALL MAGNETIC LEVITATION SYSTEM TO IMPROVE SYSTEM PARAMETERS

by

Loo Hui Shiong

A project dissertation submitted to the
Department of Electrical & Electronic Engineering
Universiti Teknologi PETRONAS
in partial fulfilment of the requirement for the
Bachelor of Engineering (Hons)
(Electrical & Electronic Engineering)

Approved:

Dr Irraivan Elamvazuthi
Project Supervisor

UNIVERSITI TEKNOLOGI PETRONAS
TRONOH, PERAK

September 2012

CERTIFICATION OF ORIGINALITY

This is to certify that I am responsible for the work submitted in this project, that the original work is my own except as specified in the references and acknowledgements, and that the original work contained herein have not been undertaken or done by unspecified sources or persons.

Loo Hui Shiong

ABSTRACT

Magnetic Levitation System (Maglev) is an approach which is currently widely applied in different areas like semiconductor, transportation, power generation, household appliances and etc. Since Magnetic Levitation System is a highly non-linear system, constructing a successful controller which has robust performance becomes a big challenge. The most conventional method of building Maglev is PID controller. However findings of controller's parameters which are K_p , K_i and K_d consume a lot of time as it requires experience personnel to do it. In this project, Ball Maglev will be used as laboratory research purpose. An algorithm name Bacteria Foraging Optimization Algorithm (BFOA) will be introduced to tune the PID controller thus enhance the performance of controller. By applying this algorithm, controller's parameters can be automatically found. The obtained parameters can then be applied to Ball Maglev and its performance can be observed, analyzed and compared with the conventional PID method. This approach enables the speed in setting the controller's parameters thus saves time in replacing the task of experience personnel. From the result, it is shown that BFOA can be applied to find the controller's gains faster than the experience personnel method. It too shows that by applying BFOA in Ball Maglev, the system reaches offset and the overshoot percentage of the system is found to be fifty percent lower than the conventional PID method although it has high settling time. In short, this project is successful as BFOA can be implemented in Ball Maglev yet still manages to portray good performance in terms of overshoot percentage. In future, BFOA can be modified to increase other system parameters, ie. settling time and rise time

ACKNOWLEDGEMENTS

I would like to express my deepest gratitude to my project supervisor, Dr. Irraivan Elamvazuthi, for his excellent advice and guidance on this project. Dr. Irraivan Elamvazuthi has provided a lot of ideas for this project. Without him, I will not have the opportunity in developing my knowledge in Magnetic Levitation field.

Special thanks to my friend, Mr. Ho Joon Heng for guiding and supporting me on the knowledge of BFOA. Mr. Ho Joon Heng has shared with me knowledge in BFOA thus enabling me to complete this project in time.

Last but not least, I would like to show my appreciation to my family for supporting me both financially and mentally. They are always there cheering me up and supporting me through the good and bad times.

TABLE OF CONTENTS

LIST OF TABLES	ix
LIST OF FIGURES	x
LIST OF ABBREVIATIONS	xi
CHAPTER 1 INTRODUCTION.....	1
1.1 Background of Study.....	1
1.2 Problem Statement	2
1.3 Objective and Scope of Study.....	2
1.4 The Relevancy of the Project.....	3
CHAPTER 2 LITERATURE REVIEW	4
2.1 Ball Magnetic Levitation System.....	4
2.2 Related Studies on the Controller of Magnetic Levitation System..	7
2.3 Proportional Integral Derivative (PID)	9
2.3.1 Proportional Term.....	10
2.3.2 Integral Term	10
2.3.3 Derivative Term.....	10
2.4 Bacteria Foraging Optimization Algorithm (BFOA)	11
2.4.1 Chemotaxis	12
2.4.2 Swarming.....	12
2.4.3 Reproduction	13
2.4.4 Elimination and Dispersal	13
CHAPTER 3 METHODOLOGY	14
3.1 Research Methodology	14
3.1.1 Mathematical Model of Ball Magnetic Levitation System	14
3.1.2 Implementation of PID Controller in Ball Magnetic Levitation System.....	15
3.1.3 Implementation of BFOA in Ball Magnetic Levitation System	16
3.2 Project Activities.....	18
3.3 Key Milestone / Gantt Chart.....	19
3.4 Tools.....	19
CHAPTER 4 RESULTS AND DISCUSSION	20

4.1 PID as the Implemented Controller in Ball Magnetic Levitation System.....	20
4.2 BFOA as the Implemented Controller in Ball Magnetic Levitation System.....	25
CHAPTER 5 CONCLUSION	28
REFERENCES	29
APPENDICES	32
Appendix A Different techniques used in Maglev	33
Appendix B Gantt chart / key milestone	35
Appendix C certificate of science and engineering design exhibition (sedex)	36

LIST OF TABLES

Table 1 : Gantt Chart of Project with Key Milestone.	19
Table 2 : Performance Parameters of PID in Maglev with Different Kd.	23
Table 3 : Performance Parameters of PID in Maglev with Different Ki.	24
Table 4 : Performance Parameters of PID in Maglev with Different Ki.	25
Table 5 : Performance Parameters of PID and BFOA.	26
Table 6 : Controller Parameters of PID and BFOA.	27

LIST OF FIGURES

Figure 1 : Electromagnetic Levitation System Model.	4
Figure 2 : Block Diagram of a PID Controller.	9
Figure 3 : Swimming and Tumbling Action Performed by a Bacterium.	11
Figure 4 : Block Diagram of a Ball Magnetic Levitation System.	15
Figure 5 : Flowchart of a BFOA codes.	17
Figure 6 : Flow of Project Activities.....	18
Figure 7 : Block Diagram of Implementation of PID Controller in Ball Magnetic Levitation System in Matlab Simulink.	20
Figure 8 : Output Response of P Controller in Ball Magnetic Levitation System.	21
Figure 9 : Output Response of PI Controller in Ball Magnetic Levitation System.	21
Figure 10 : Output Response of PD and PID Controller in Ball Magnetic Levitation System.....	22
Figure 11 : Output Response of PID Controller with Different Kd.	22
The value of Kd is examined from the range of 0.2 to 0.8 because range beyond this will cause unstable system. It is observed that the rise time, settling time and percentage overshoot of the system decreases with Kd increases. A summary of the performance parameters can be observed in Table 2.	23
Figure 12 : Output Response of PID Controller with Different Ki.	23
Figure 13 : Output Response of PID Controller with different Ki.	24
Figure 14 : Block Diagram of Implementation of BFOA in Ball Magnetic Levitation System in Matlab Simulink.	25
Figure 15 : Output Response of BFOA Being Implemented in Ball Magnetic Levitation System.	26

LIST OF ABBREVIATIONS

MAGLEV	-	Magnetic Levitation System
PID	-	Proportional-Integral-Derivative
BFOA	-	Bacteria Foraging Optimization Algorithm
ISE	-	Integral Squared Error
SMC	-	Sliding-Mode Controller
FSMC	-	Fuzzy Sliding-Mode Controller
NFSMC	-	Novel Fuzzy Sliding-Mode Controller
NN	-	Neural Network

CHAPTER 1

INTRODUCTION

1.1 Background of Study

Magnetic Levitation System, also known as “Maglev” is a method used to suspend an object without any support other than magnetic field. According to Earnshaw’s theorem, it is proven that the application of only static ferromagnetism, levitate stably against gravity is impossible. However servomechanisms which are superconduction, the use of diamagnetic material, or systems which involve eddy currents allow this levitation to occur. Lifting force is contributed by magnetic levitation in some cases but a mechanical support bearing little load does help in the stability. Pseudo-levitation is the term [1]. This method is widely applied in various engineering purposes like ball magnetic levitation system, high-speed maglev train, wind turbine and vibration isolation table [2][3]. As this method applies electromagnetic force to suspend the rotor, mechanical contact does not appear between the rotor and stator which in short it is wear-free and contact-free suspension [4]. Magnetic Levitation System offers a large series of benefits such as [2][5][6]:

- Improve speed performance (No mechanical contact between object contributes to no friction except air friction.)
- Decrease the consumption of energy (Reduction of friction saves the energy.)
- Reduce cost maintenance (Since no mechanical contact between objects, lubricant is not needed to reduce the friction or to enhance the smoothness of system.)
- Controllable support force (Magnetic force can be varies with the voltage applied to the electromagnet to suspend the targeted object)

In this project, the main focus of Magnetic Levitation System will be on Maglev’s ball bearingless system.

1.2 Problem Statement

Magnetic Levitation System is a type of repulsive system which based on the source of levitates force [2]. Its behavior of having non-uniform magnetic field has contributed to one of the most difficult concerns as a matter of fact, the magnetic fields are highly non-linear. The strength of a magnetic field depends on both the orientation of the field at the source and the respective target and distance to the source [1]. Although this system is widely applied in various fields, this difficult aspect causes the system difficult to be controlled. Constructing a successful controller which has high performance to regulate the position of the levitated steel ball becomes a big challenge. The most conventional and simplest approach to build a magnetic levitation system is by using Proportional Integrated Derivative (PID). However PID controller parameters are hard to tune and it requires experienced person to do the tuning. Also, PID controller gain is proportional with time integral. When K_p is bigger, the output response tends to have smaller offset value but the process will become more oscillatory where else if T_i becomes bigger, the offset turns big but the process becomes lesser oscillatory [2].

1.3 Objective and Scope of Study

The main objectives of this project are:

- To understand the working principle of Bacteria Foraging Optimization Algorithm (BFOA).
- To study the performance of intelligent algorithm like BFOA in Magnetic Levitation System.
- To compare performance of implementing PID and BFOA in Magnetic Levitation System.
- To determine the most crucial system parameters to be improved in Magnetic Levitation System.

Scope of study will take into considerations parameters that affect the overall Magnetic Levitation System such as percentage overshoot, steady state error, rise time and ISE (Integral of Square Error) after implementing the new algorithm which is Bacteria Foraging Optimization Algorithm (BFOA) into the PID controller.

1.4 The Relevancy of the Project

This project will compare the methods in implementing Magnetic Levitation System. Taking into consideration of the related system parameters, the selected control algorithm will then be modified for implementing a new control algorithm in Magnetic Levitation System. A good controller of Magnetic Levitation System will be very beneficial to not only educational purpose but also to engineering applications.

CHAPTER 2

LITERATURE REVIEW

2.1 Ball Magnetic Levitation System

The model of the electromagnetic levitation system is shown in Figure 1, where R is the resistance of the coil, L is the inductance of the coil, v is the voltage across the electromagnet, i is the current through the electromagnet, m is the mass of the levitating magnet, g is the acceleration due to gravity, d is the vertical position of the levitating magnet measured from the bottom of the coil, f is the force on the levitating magnet generated by the electromagnet and e is the voltage across the Hall effect sensor. The Hall Effect sensor is connected to one of the analog input of a Hilink control board and the electromagnet is driven by one of the H-bridges of the same board.

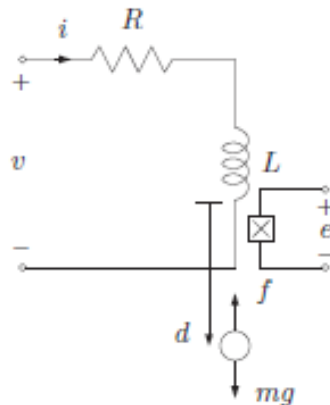

Figure 1 : Electromagnetic Levitation System Model.

The force applied by the electromagnet on the levitating magnet can be closely approximated as

$$f = k \frac{i}{d^4}$$

where k is a constant that depends on the geometry of the system [27]. The voltage across the Hall Effect sensor induced by the levitation magnet and the coil can be closely approximated as

$$e = \alpha + \beta \frac{1}{d^2} + \gamma i + n$$

where α, β and γ are constants that depend on the Hall Effect sensor used as well as the geometry of the system and n is the noise process that corrupts the measurement [28]. It follows from Newton's second law that

$$m\ddot{d} = mg - k \frac{i}{d^4}$$

Moreover, it follows from the Kirchoff's voltage law that

$$v = Ri + Li$$

Letting $x = [x_1 \ x_2 \ x_3] = [d \ \dot{d} \ i]$ be the state of the system, $z = d$ be the controlled output, $y = e$ be the measured output, $u = v$ be the control input and $w = n$ be the disturbance/noise, the standard state equation description of the system can be written as

$$\begin{bmatrix} \dot{x}_1 \\ \dot{x}_2 \\ \dot{x}_3 \end{bmatrix} = \begin{bmatrix} x_2 \\ -\frac{k}{m} \frac{x_3}{x_1^4} + g \\ -\frac{R}{L} x_3 + \frac{1}{L} u \end{bmatrix},$$

$$z = x_1,$$

$$y = \beta \frac{1}{x_1^2} + \gamma x_3 + \alpha + w$$

The equilibrium points of the system are at

$$\begin{bmatrix} x_{1e} \\ x_{2e} \\ x_{3e} \end{bmatrix} = \begin{bmatrix} \pm \left(\frac{ku_e}{gmR} \right)^{1/4} \\ 0 \\ \frac{u_e}{R} \end{bmatrix},$$

Where u_e is the required equilibrium coil voltage to suspend the levitating magnet at $x_{1e} = \pm d_e$. Clearly, the equilibrium point that is of interest is the one with the positive sign.

The Jacobian linearization of the system about the equilibrium point is

$$\delta \dot{x} = A\delta x + B_1\delta w + B_2\delta u,$$

$$\delta z = C_1\delta x + D_{11}\delta w + D_{12}\delta u,$$

$$\delta y = C_2\delta x + D_{21}\delta w + D_{22}\delta u,$$

where $\delta x = x - x_e$, $\delta w = w - w_e$, $\delta u = u - u_e$, $\delta z = z - z_e$, $\delta y = y - y_e$ and

$$A = \begin{bmatrix} 0 & 1 & 0 \\ \frac{4g(gmR)^{1/4}}{(ku_e)^{1/4}} & 0 & -\frac{gR}{u_e} \\ 0 & 0 & -\frac{R}{L} \end{bmatrix}, \quad B_1 = \begin{bmatrix} 0 \\ 0 \\ 0 \end{bmatrix}, \quad B_2 = \begin{bmatrix} 0 \\ 0 \\ \frac{1}{L} \end{bmatrix},$$

$$C_1 = [1 \quad 0 \quad 0], \quad D_{11} = [0], \quad D_{12} = [0],$$

$$C_2 = \begin{bmatrix} -\frac{2\beta(gmR)^{3/4}}{(ku_e)^{3/4}} & 0 & \gamma \end{bmatrix}, \quad D_{21} = [1], \quad D_{22} = [0],$$

Note that $w_e = 0$, $z_e = x_{1e}$ and $y_e = \frac{\beta}{x_{1e}^2} + \gamma x_{3e} + \alpha$.

The transfer matrix of the linearized system is

$$P(s) = \begin{bmatrix} 0 & \frac{-\frac{gR}{u_e L}}{\left(s + \frac{R}{L}\right) \left[s^2 - \frac{4g(gmR)^{1/4}}{(ku_e)^{1/4}}\right]} \\ \frac{\gamma}{L} s^2 + \left[\frac{2\beta g R (gmR)^{3/4}}{L u_e (ku_e)^{3/4}} - \frac{4\gamma g (gmR)^{1/4}}{L (ku_e)^{1/4}} \right] & \\ 1 & \frac{\left(s + \frac{R}{L}\right) \left[s^2 - \frac{4g(gmR)^{1/4}}{(ku_e)^{1/4}}\right]}{\left(s + \frac{R}{L}\right) \left[s^2 - \frac{4g(gmR)^{1/4}}{(ku_e)^{1/4}}\right]} \end{bmatrix}$$

Note that

$$\begin{bmatrix} \Delta Z(s) \\ \Delta Y(s) \end{bmatrix} = P(s) \begin{bmatrix} \Delta W(s) \\ \Delta U(s) \end{bmatrix},$$

Where $\Delta Z(s)$, $\Delta Y(s)$, $\Delta W(s)$ and $\Delta U(s)$ are the Laplace transform of $\delta z(t)$, $\delta y(t)$, $\delta w(t)$ and $\delta u(t)$, respectively.

In this derivation, the back emf induced by the moving levitating magnet is ignored as it is very small. If the Hall Effect sensor is located below the levitating magnet and the γ is very small, it can also be neglected.

2.2 Related Studies on the Controller of Magnetic Levitation System

Since years ago, Magnetic Levitation System is widely used in all kind of sectors. In this project, magnetic levitation (maglev) ball system will be taken as prime concern. Ball Magnetic levitation system which has single degree of freedom is a typical integration of electrical and mechanical systems. This Maglev's ball bearingless system acts as a platform to study magnetic levitation technology and can be used as a research base for vertical magnetic bearing apparatuses [7].

In year 1996, Walter Bariet et al. proposed the idea of non-linear and linear state space controllers for magnetic levitation system. Performance in controlling the ball's position is to be compared using the controllers in the research. In his research, the linear controller is based on feedback linearization where the transformation of a nonlinear state-space along with nonlinear state feedback functions to linearize the system. The paper shows that the position tracking error of the system was oscillation about ± 0.45 mm [8].

Another author name Dan Cho Et al proposed the idea of sliding mode control (SMC) to solve the parameter uncertainties issue and reject disturbances to achieve robust performance. The paper presents the implementation of SMC into a magnetic levitation system and result has shown that SMC has better performance compared to classical controllers [9]. A conventional controller for example a PID controller is a very simple and reliable controller. PID controller applies the method based on a linearization of the systems dynamics and compensates the effects of the non-modeled nonlinearity. PID controller enables the systems to be stabilized close to their nominal operating point. An author name Wenbai Chen et al said, a PID controller is robust and reliable with condition its controller parameters determined or tuned, linearizing the system. A method name chaos optimization which contributes in PID parameter setting is proposed by him. This method helps in optimize the performance of PID controller [10].

Zadeh et al introduce a set of theory name fuzzy which has become a very useful and powerful modeling tool. It can work with highly non-linear and unstable system. It is categorized as an intelligent control and if to be compare with PID controller, its parameters can be easily tuned by non-experts. According to author Tzue-Hseng S Li et al, by applying Fuzzy Sliding Mode Controller (FSMC), the system can achieve the asymptotic stability. This type of controller is very helpful as with this controller, we do not have to know in detail [11]. An author name Chao-lin Kuo comes out with the idea of Novel Fuzzy Sliding-Mode Control (NFSMC) and his paper presents the comparison effect of uncertainty in the ball mass between Sliding-Mode controller, Fuzzy Sliding-Mode controller and NFSMC. Based on the result, it is shown that NFSMC shows the least IAE and ISV performance [12]. The study proves that Fuzzy Logic Controller has good potential to stabilize the ball levitation in this research.

It is proven through experimental studies that Sliding-Mode Control, inverse model based adaptive control and robust position control for controlling the magnetic levitation system can work effectively on Maglev [13], [14], [15], [16]. These methods have different advantages. However, it is compulsory for these controllers to have mathematical model, disturbances for their respective controlled plant and to derive the regulator parameters from some control design procedure [13], [14], [15], [16]. The negative aspects of such procedure is that it consumes a long period of time meantime requires skillful personnel in identifying, modeling the system and control designing.

PID which is designed through linear policy [17], [18] can offer linear or non-linear PID control by applying the idea of fuzzy. Unfortunately, the non-linearity of Fuzzy PID (FPID) makes it complicated to determine the controller gains compared to the linear PID controller [19], [20]. The application of neural network (NN) in control system offers satisfied developments in system performance. NN acts in compensating incorrect selection of parameter gains of the FPID controller and also to stabilize the magnetic levitation system. A FPID controller without earlier details of controlled plant is developed and NN is added in parallel with the controller. NN will only operate in taking over the controller if the parameter gains of the FPID controller behave incorrectly [21]. For quick review of different techniques discussed in different journals, kindly refer to Appendix A.

2.3 Proportional Integral Derivative (PID)

A Proportional Integral Derivative (PID) controller is the most common controller used in various industries to control their systems. Generally, a PID controller measures the error value from the difference between a measured process variable and a targeted setpoint. Along the process, PID controller will try to minimize the error value by adjusting the controlled input of the system [29].

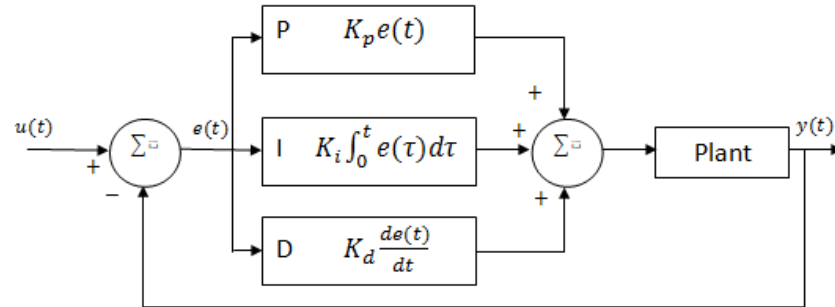

Figure 2 : Block Diagram of a PID Controller.

PID algorithm involves three modes which are Proportional, Integral and Derivative mode. The control of system can be performed with different actions for example P, PI or PID. This can be done by setting other parameters to zero. The final form of the PID algorithm is [29]:

$$u(t) = MV(t) = K_p e(t) + K_i \int_0^t e(\tau) d\tau + K_d \frac{d}{dt} e(t)$$

Where $MV(t)$: Manipulated variable,

$u(t)$: Controller output,

K_p : Proportional gain,

K_i : Integral gain,

K_d : Derivative gain,

e : Error = $SP - PV$,

τ : Variable of integration,

t : Time (Present time).

2.3.1 Proportional Term

It contributes to an output value which is proportional to the present error. The proportional response is obtained by multiplying a constant value name K_p with the error. High proportional gain, for a given change in error can cause huge change in the system output. System tends to be unstable when K_p is too high where else if K_p is too low, the controller becomes less sensitive or responsive to the system disturbances.

$$P_{out} = K_p e(t)$$

2.3.2 Integral Term

The integral term is proportional to the error value and the period of the error. It corrects present error occur between process output and desired setpoint over time. Then the accumulated error is multiplied with a constant name K_i before added into the output of controller.

$$I_{out} = K_i \int_0^t e(\tau) d\tau$$

This term helps the process in achieving desired setpoint faster and removes the offset value with the aid of a proportional controller. Due to the characteristic of responding to accumulated past errors, integral term can cause the present value to overshoot to unwanted value.

2.3.3 Derivative Term

The derivative action is used to improve dynamic response of system. For example, the derivative mode functions to decrease the overshoot value caused by the integral term thus improve the stability of system. However, due to the existence of differentiating noisy signals, this action becomes unstable when the derivative gain and noise appear to be very large.

$$D_{out} = K_d \frac{d}{dt} e(t)$$

Derivative action solely depends on the error slope. It has no effect if the error appears to be constant.

2.4 Bacteria Foraging Optimization Algorithm (BFOA)

The term BFOA is inspired by behaviour of bacteria in foraging and such bacteria is like *E. coli* and *M. xanthus*. The idea is based on the chemotaxis behaviour of bacteria where they will distinguish nutrients around them thus moving towards or away from the respective signals.

The foraging action is done by using locomotion mechanisms or flagella. With this, *E. coli* bacteria can tumble or swim around in the environment [30]. Rotating the flagella in clockwise direction enables the flagellum pulls on the cell, causing the flagella to move independently and then they will go tumbling in lesser number. When they reach a noxious environment, they will quickly seek for nutrient gradient. In contrast, when their flagella are moved in counter-clockwise direction, they will be able to swim a high speed rate. Usually, when the bacteria are at a safe environment, they tumble for a longer distance.

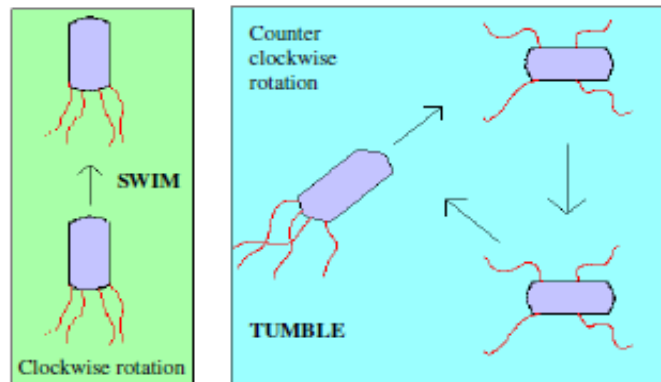

Figure 3 : Swimming and Tumbling Action Performed by a Bacterium.

When sufficient food is obtained, their length will be increased. With the presence of correct temperature, they will break into half to form their replica and this is termed reproduction. However, the chemotactic progress may be interrupted and ruined when gradual environmental changes occur. This will result in them shifting to other places or some bacteria may be included in the swarming purpose and this is named elimination-dispersal in the population of the bacteria.

Generally, BFOA imitates the four working principle of *E. coli* bacteria which are chemotaxis, swarming, reproduction and elimination-dispersal.

2.4.1 Chemotaxis

This process refers to the tumbling and swimming action performed by the E. coli bacteria via flagella. In real life, E. coli bacteria can move in two ways and tumble for a long period of time with condition the environment is friendly to them.

The chemotaxis movement of bacteria can be signified by the formula below based on few assumptions.

$$\theta^i(j+1, k, l) = \theta^i(j, k, l) + C(i) \frac{\Delta(i)}{\sqrt{\Delta^T(i)\Delta(i)}} \quad (1)$$

- i. $\theta^i(j, k, l)$ means i -th bacterium at j -th chemotactic, k -th reproductive and l -th elimination-dispersal step.
- ii. $C(i)$ is the step size taken in random direction specified by the tumble.
- iii. Δ is a vector in random direction whose elements lie in $[-1, 1]$.

2.4.2 Swarming

It is observed that in E. coli bacteria, stable and complicated spatio-temporal patterns (swarms) are formed in semisolid nutrient medium. When placed amidst a semisolid matrix with a single nutrient chemo-effector, the bacteria will group themselves in a traveling ring by moving up the gradient of nutrient. Stimulated by a high level of succinate, the bacteria will attract others by releasing an attractant name aspartate and then move in concentric patterns of swarms. Suppose $J_{cc}(\theta, P(j, k, l))$ is the objective function value added to the actual objective function (to be minimized) to present a time varying objective function, p is the number of variables to be optimized, which are present in each bacterium, S is the total number of bacteria and $\theta = [\theta_1, \theta_2, \dots, \theta_p]^T$ is a point in the p -dimensional search domain. $d_{attractant}$, $w_{attractant}$, $h_{repellant}$, $w_{repellant}$ are different coefficients that should be chosen properly [30]. This swarming behavior can be represented by

$$J_{cc}(\theta, P(j, k, l)) = \sum_{i=1}^S J_{cc}(\theta, \theta^i(j, k, l)) \quad (2)$$

$$= \sum_{i=1}^S \left[-d_{attractant} \exp\left\{-w_{attractant} \sum_{m=1}^p (\theta_m - \theta_m^i)^2\right\}\right] + \sum_{i=1}^S \left[-h_{repellant} \exp\left\{-w_{repellant} \sum_{m=1}^p (\theta_m - \theta_m^i)^2\right\}\right]$$

2.4.3 Reproduction

Bacteria which are weak will die while the stronger one continues to survive and split into two to create replica. This can then balance the population of bacteria in that particular area.

2.4.4 Elimination and Dispersal

When sudden changes occur in environment, the bacteria might be eliminated or dispersed to other locations with randomly liquidated over the search place.

CHAPTER 3

METHODOLOGY

3.1 Research Methodology

3.1.1 Mathematical Model of Ball Magnetic Levitation System

Letting the desired d_e be 2.00×10^{-2} m and using measurement obtained by the Hilink platform, the parameters of the electromagnetic levitation system are determined as

$$\begin{aligned}
 R &= 2.41\Omega, & L &= 15.03 \times 10^{-3}\text{H}, & m &= 3.02 \times 10^{-3}\text{kg}, \\
 g &= 9.81\text{m/s}^2, & k &= 17.31 \times 10^{-9} \text{kgm}^5/\text{s}^2/\text{A}, & \alpha &= 2.48 \text{V}, \\
 \beta &= 2.92 \times 10^{-4}\text{Vm}^2, & \gamma &= 0.48 \text{V/A}, & u_e &= 0.66 \text{V}, \\
 x_{1e} &= 2.00 \times 10^{-2}\text{m}, & x_{2e} &= 0.00\text{m/s}, & x_{3e} &= 0.27 \text{A}, \\
 z_e &= 2.00 \times 10^{-2}\text{m}, & y_e &= 3.34 \text{V}, & w_e &= 0.00 \text{V}.
 \end{aligned}$$

With these parameter values, it follows that

$$\begin{aligned}
 A &= \begin{bmatrix} 0 & 1 & 0 \\ 1.9620 \times 10^3 & 0 & -35.8214 \\ 0 & 0 & -160.3460 \end{bmatrix}, & B_1 &= \begin{bmatrix} 0 \\ 0 \\ 0 \end{bmatrix}, & B_2 &= \begin{bmatrix} 0 \\ 0 \\ 66.5336 \end{bmatrix}, \\
 C_1 &= [1 \quad 0 \quad 0], & D_{11} &= [0], & D_{12} &= [0], \\
 C_2 &= [-72.9965 \quad 0 \quad 0.4800], & D_{21} &= [1], & D_{22} &= [0],
 \end{aligned}$$

and

$$P(s) = \begin{bmatrix} 0 & \frac{-2.3833 \times 10^3}{(s + 160.3460)(s^2 - 1.9620 \times 10^3)} \\ 1 & \frac{31.9361s^2 + 1.1132 \times 10^5}{(s + 160.3460)(s^2 - 1.9620 \times 10^3)} \end{bmatrix}$$

The noise process n can be modelled as a white noise with spectral height, $N = 1.00 \times 10^{-9} \text{ V}^2\text{s}$.

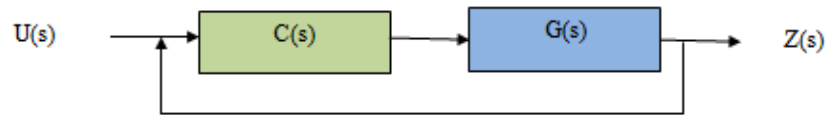

Figure 4 : Block Diagram of a Ball Magnetic Levitation System.

The system is represented by $G(s)$ while $C(s)$ is the controller in the system. $U(s)$ is the controlled input which is the applied coil voltage while $Z(s)$ is the gap distance between steel ball and Hall Effect sensor.

In most control applications, the measured plant output is equal to the controlled plant output. However, there are several important applications in which the measured plant output is not equal to the controlled plant output. For such a system, there are several different plant transfer functions from different plant inputs to outputs. For example, one may measure the temperature but want to control the pressure of a process. In the magnetic levitation system, the measured variable is the Hall Effect sensor output e and we would like to control the gap distance d not e . Thus, the feedback is from e .

The transfer function of the system is

$$G(s) = \frac{31.9361s^2 + 1.1132e5}{s^3 + 1.01859s^2 + 0.79799s}$$

3.1.2 Implementation of PID Controller in Ball Magnetic Levitation System

Implementation of PID controller in Ball Maglev required experience personnel to do the tuning in controller parameters which are K_p , K_i and K_d . The PID controller will take the parameters to run the system.

3.1.3 Implementation of BFOA in Ball Magnetic Levitation System

BFOA uses codes to run the system in order to find the best controller parameters for the system. Figure 5 illustrates the flowchart of steps to be done by BFOA [30].

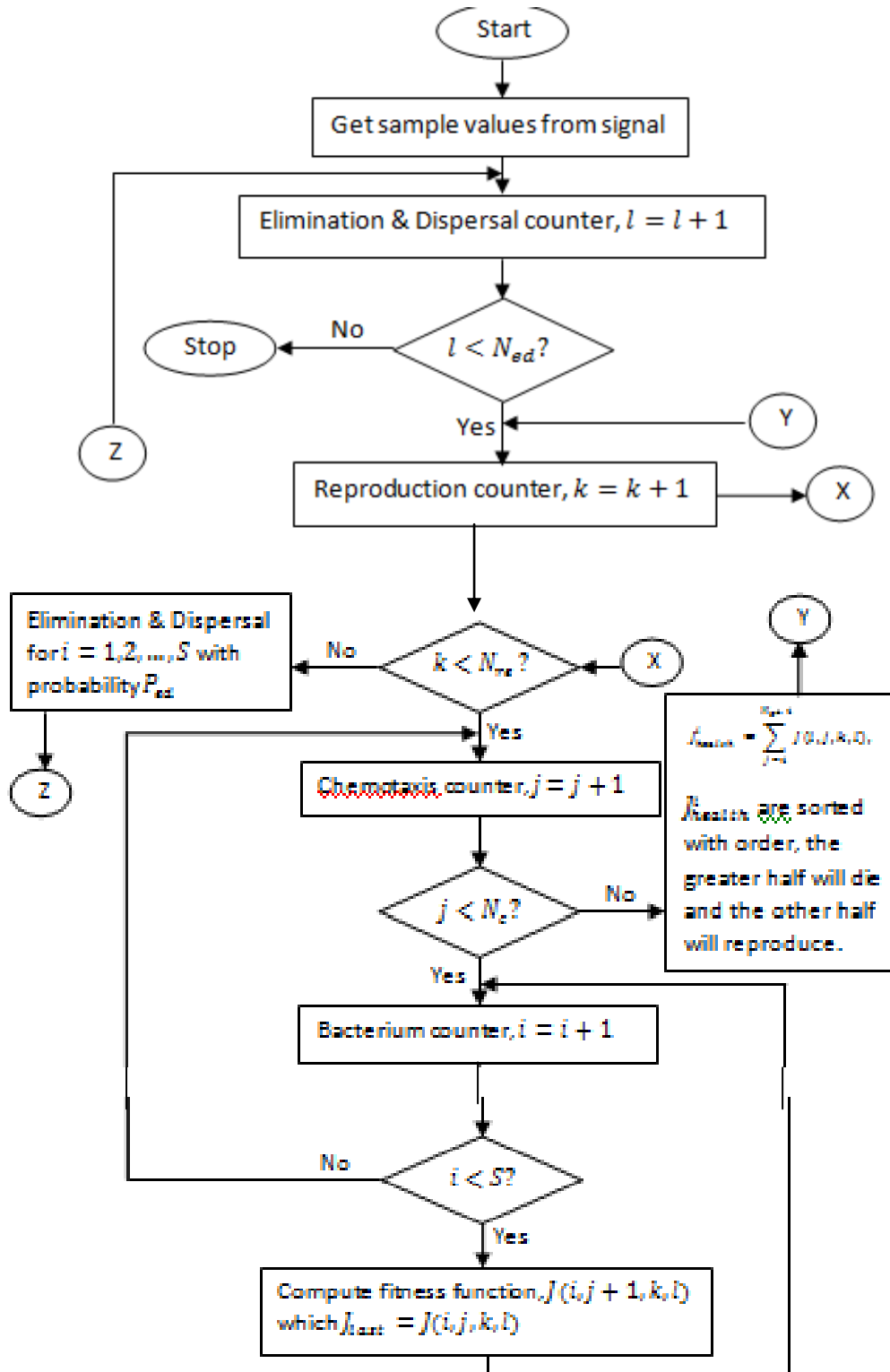

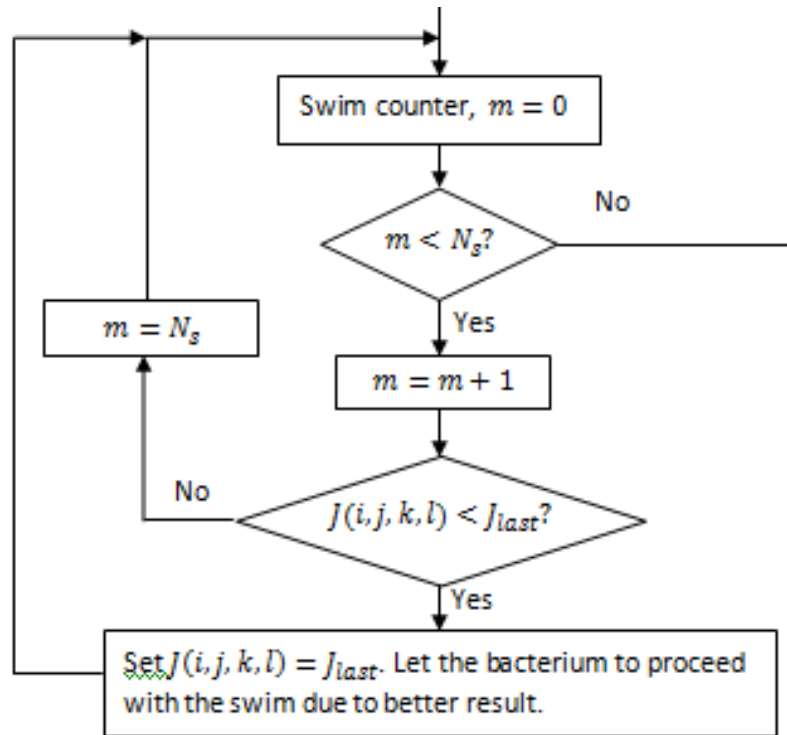

Figure 5 : Flowchart of a BFOA codes.

This flowchart is based on the 4 working principles of E. Coli which are chemotaxis, swarming, reproduction and elimination and dispersal. . At the end of the code, J_{last} with the smallest value which represents the Integral Squared Error (ISE) will be chosen.

3.2 Project Activities

Figure 6 shows steps to complete this project. Activities to complete this project are illustrated in it.

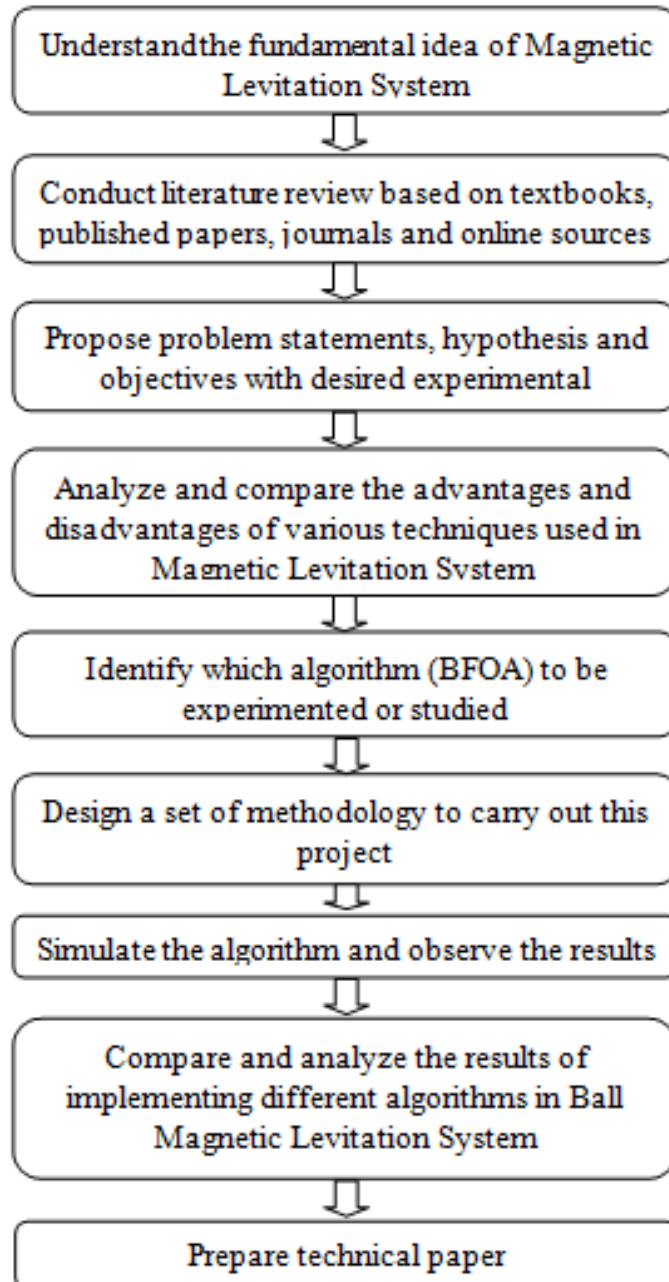
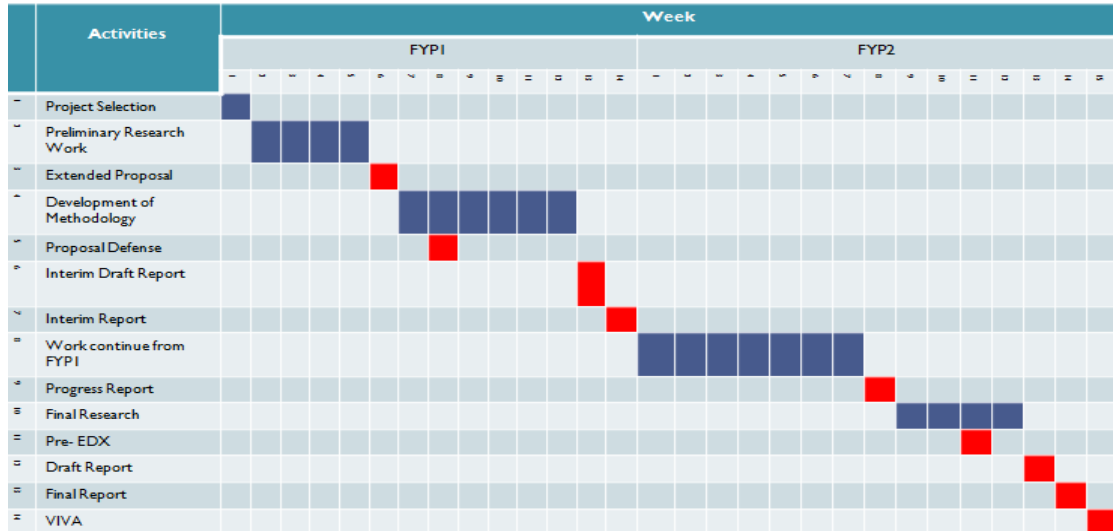

Figure 6 : Flow of Project Activities.

3.3 Key Milestone / Gantt Chart

Table 1 shows the tasks that need to be completed and the dates of completing them. It is a Gantt Chart of the project with the key milestones included to show the progress and schedule of the project.

Table 1 : Gantt Chart of Project with Key Milestone.



For larger version of Gantt Chart, kindly refer to **Appendix B**.

3.4 Tools

In this project, a lot of tools and equipments are needed in order to make the project a success. Software is needed to design and simulate the controllers. Software required includes MATLAB and Simulink. This software can be obtained from lab technicians or downloaded in internet. As for ball magnetic levitation kit, it is used during presentation. By showing the judges and audience the magnetic levitation kit, it can help to ease their understanding on this topic.

Software:

- MATLAB
- Simulink

Hardware:

Magnetic Levitation Kit

CHAPTER 4

RESULTS AND DISCUSSION

Before we proceed with the comparison between PID and BFOA controller in Ball Magnetic Levitation, the section below investigates on reason PID is chosen instead of P, PI or PD mode.

4.1 PID as the Implemented Controller in Ball Magnetic Levitation System

To implement different PID mode, one can simply insert zero to unrelated controller parameters. Figure 7 shows the block diagram of PID controller being implemented in Ball Magnetic Levitation System in Simulink.

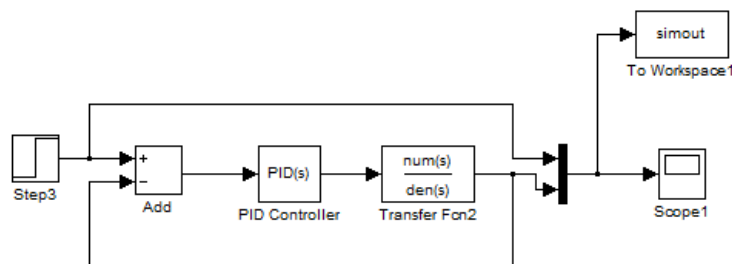

Figure 7 : Block Diagram of Implementation of PID Controller in Ball Magnetic Levitation System in Matlab Simulink.

If P or PI mode is to be implemented into the system, the system will yield unstable response as shown in Figure 8 and 9. The yellow line refers to the position of steel ball with P and PI mode implemented into the respective system.

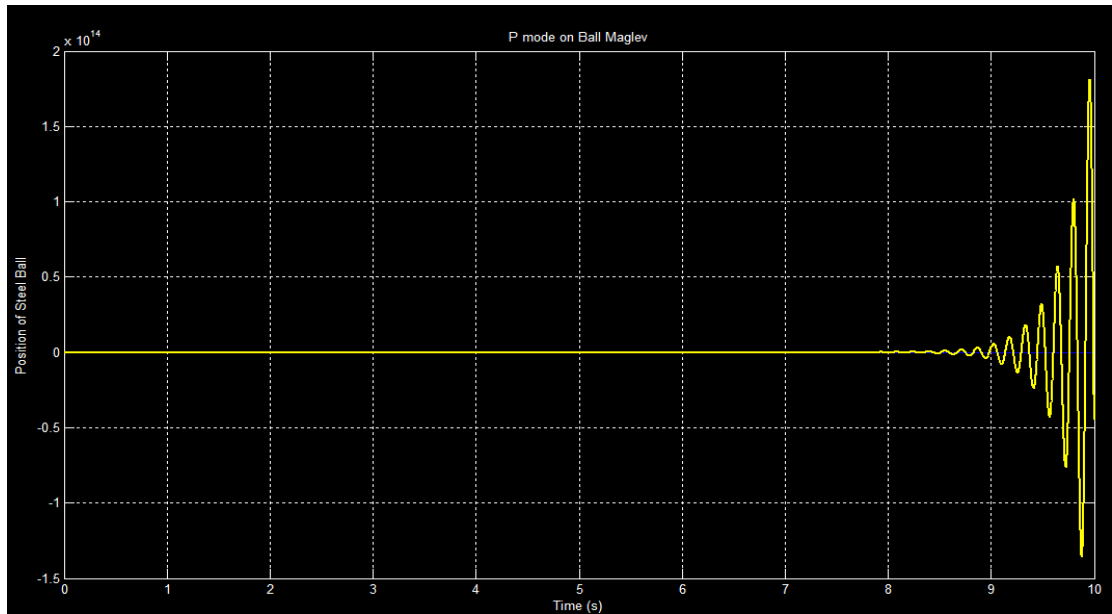

Figure 8 : Output Response of P Controller in Ball Magnetic Levitation System.

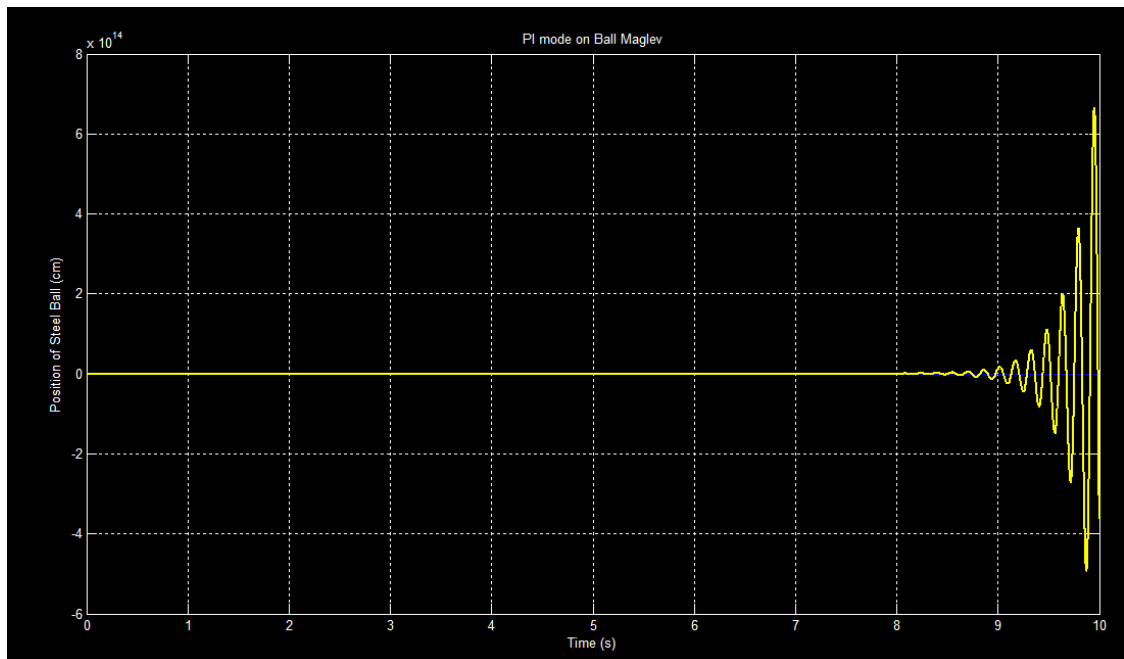

Figure 9 : Output Response of PI Controller in Ball Magnetic Levitation System.

As for PD mode, it is still inappropriate to be used in Ball Magnetic Levitation System. This is because compared to PID mode, PD controller will produce steady state error while PID controller can reach zero steady state error. This can be seen in Figure 10. The purple line represents the output response of applying PD controller in

the system while green line is the location of steel ball with PID as the controller. This clearly shows the reason why PID is chosen to be implemented in Ball Magnetic Levitation System.

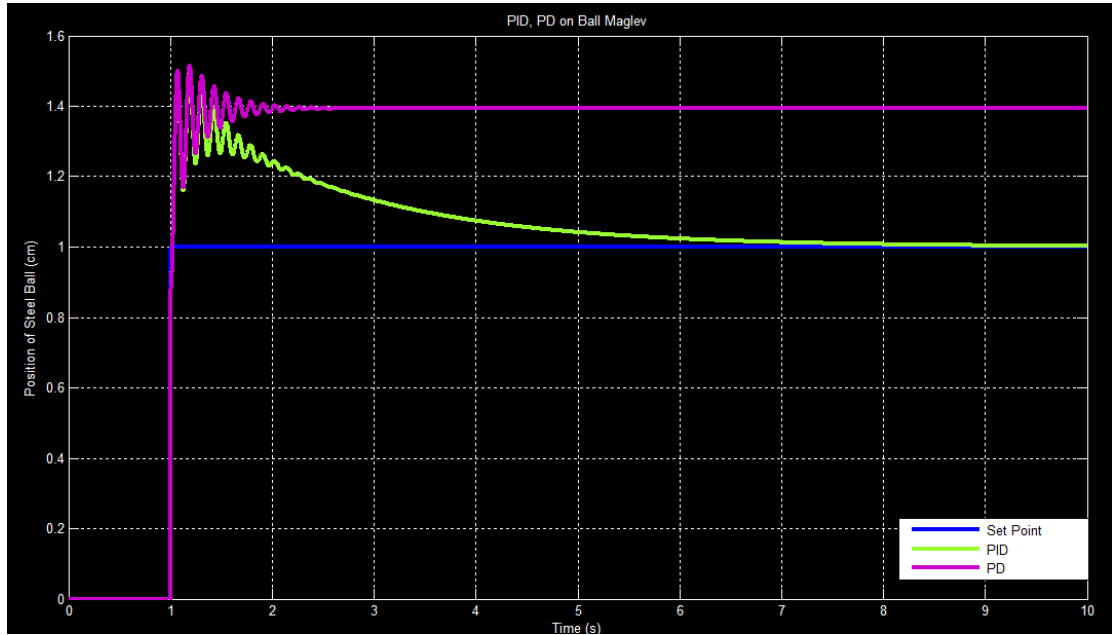

Figure 10 : Output Response of PD and PID Controller in Ball Magnetic Levitation System.

Next the parameter values of K_i and K_d are to be varied and examined to see the response of the system. Do note that the controller parameters provided by experience personnel is $K_p = 10$, $K_i = 4$ and $K_d = 0.5$. Since controller PD is used to stabilize the system, the K_d value are to be varied first with $K_p = 10$, $K_i = 4$. The response of system is shown in Figure 11 with green line represents K_p value of 0.5, red line is 0.2, blue line is 0.7 and purple line represents 0.8.

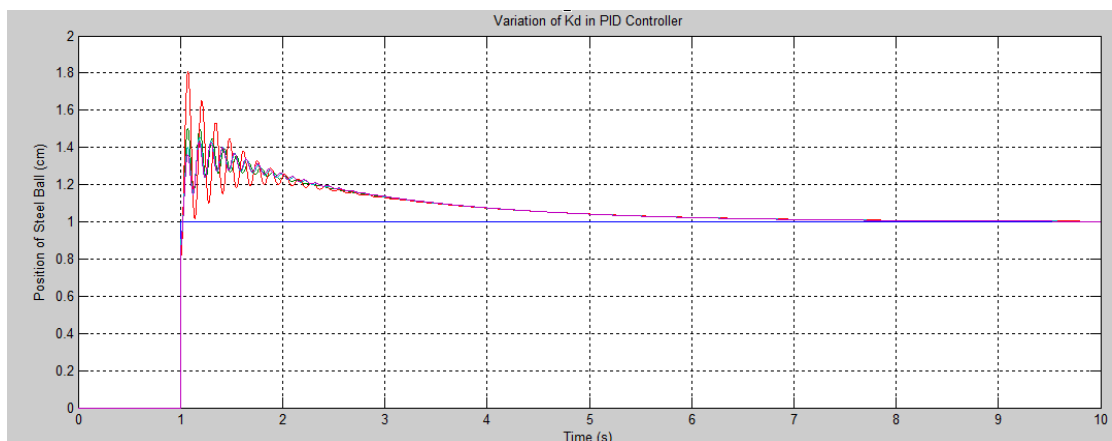

Figure 11 : Output Response of PID Controller with Different K_d .

The value of K_d is examined from the range of 0.2 to 0.8 because range beyond this will cause unstable system. It is observed that the rise time, settling time and percentage overshoot of the system decreases with K_d increases. A summary of the performance parameters can be observed in Table 2.

Table 2 : Performance Parameters of PID in Maglev with Different K_d .

K_p	K_i	K_d	Rise Time	Settling Time	%OS	Peak
10	4	0.2	0.0169	5.31	80.9	1.81
10	4	0.5	0.0121	5.27	50.2	1.5
10	4	0.7	0.00164	5.24	45.1	1.45
10	4	0.8	0.00143	5.22	42.8	1.43

Controller PI is used to eliminate errors and offset of the system response. The range of K_i to be examined is from 4 to 100. The reason this range is chosen is because value beyond this range will yield poorer results. At this stage, the value of K_p is fixed to be 10 and K_d is 0.5. The system response is shown in Figure 12.

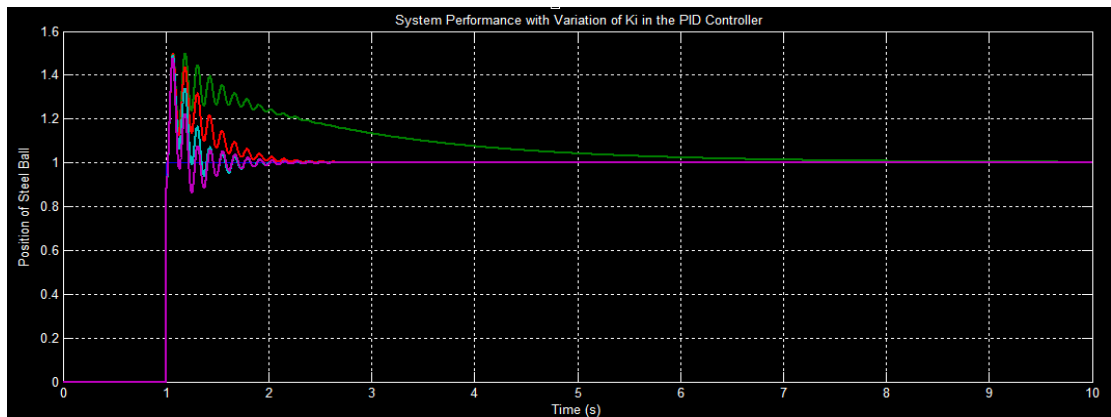

Figure 12 : Output Response of PID Controller with Different K_i .

The green line of the system response represents K_i value = 4, red line is 20, blue line is 50 and purple line is 100. As you can see from Figure 12, K_i values with 50 and 100 yield the best response of all. In terms of rise time, settling time and percentage overshoot, their responses are the lowest. A summary of performance parameters is shown in Table 3.

Table 3 : Performance Parameters of PID in Maglev with Different K_i .

K_p	K_i	K_d	Rise Time	Settling Time	%OS	Peak
10	4	0.5	0.0121	5.27	50.2	1.5
10	20	0.5	0.0121	1.05	49.8	1.5
10	50	0.5	0.0118	0.749	49	1.49
10	100	0.5	0.0114	0.806	47.8	1.48

Next the parameters of K_p with value 10 and K_d with value 0.8 are tested with K_i value of 50 and 100. The result is shown in Figure 13. Both portray almost similar results but K_i with value of 50 has smaller settling time with slightly higher percentage overshoot.

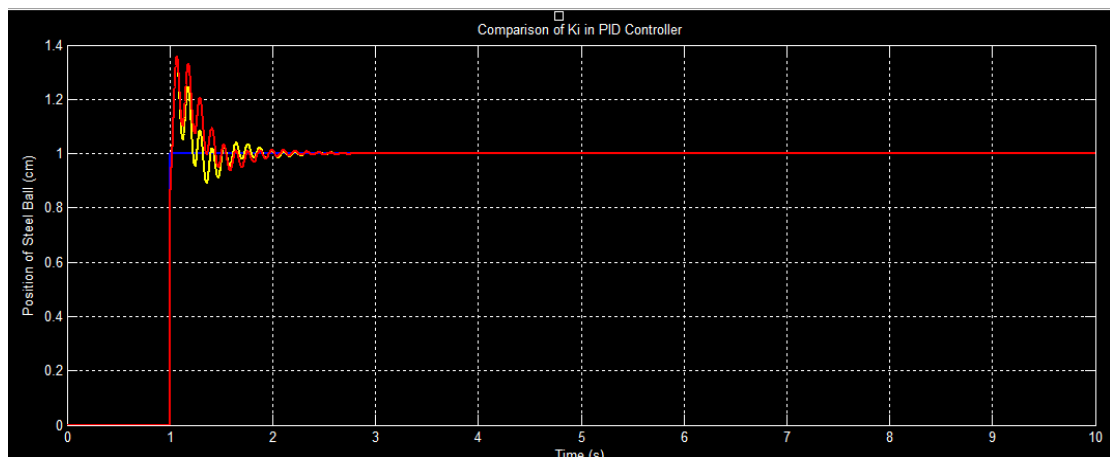

Figure 13 : Output Response of PID Controller with different K_i .

A clearer result can be observed in Table 4.

Table 4 : Performance Parameters of PID in Maglev with Different Ki.

Kp	Ki	Kd	Rise Time	Settling Time	%OS	Peak
10	50	0.8	0.0012	0.836	35.8	1.36
10	100	0.8	0.0012	0.884	35.2	1.35

After applying the trial and error method with reference to the controller parameters given by developer, it is shown that controller parameters in Table 4 yield better results.

4.2 BFOA as the Implemented Controller in Ball Magnetic Levitation System

As for BFOA, the block diagram in Simulink is illustrated in Figure 14. BFOA is added into the diagram, functions to seek the best controller parameters of PID and then insert them as input into the controller.

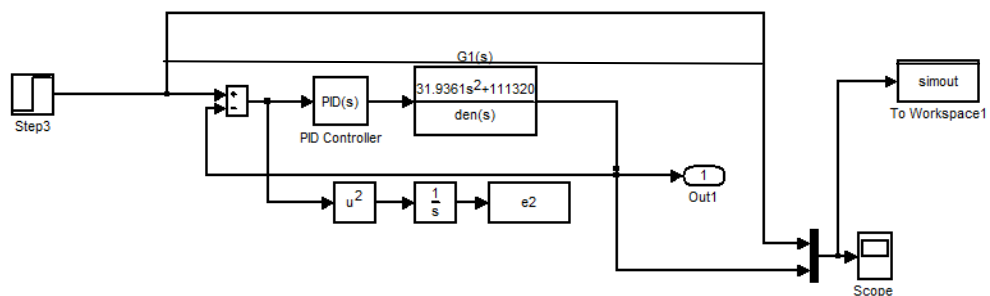

Figure 14 : Block Diagram of Implementation of BFOA in Ball Magnetic Levitation System in Matlab Simulink.

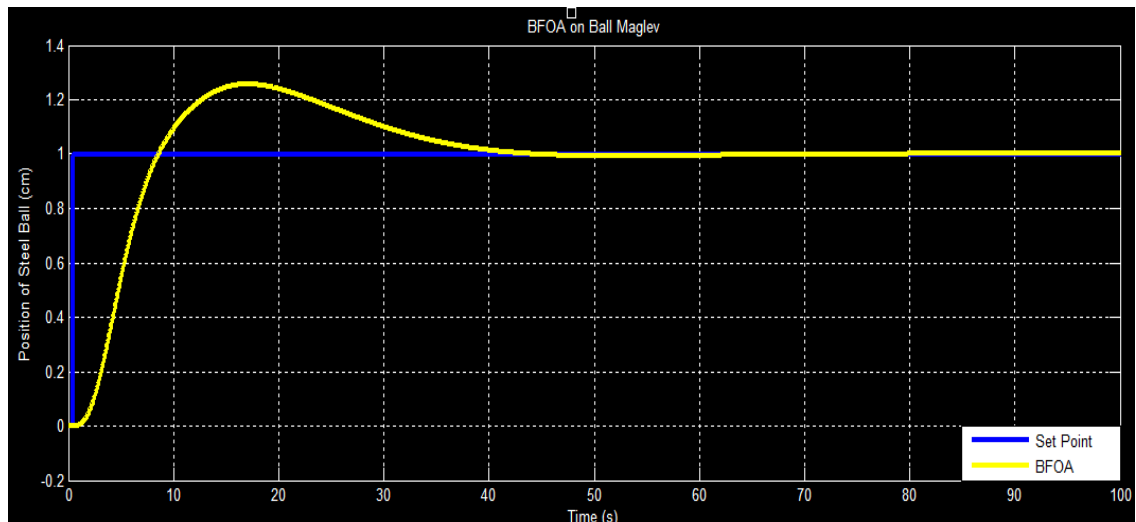

Figure 15 : Output Response of BFOA Being Implemented in Ball Magnetic Levitation System.

The yellow line represents the position of steel ball with BFOA implemented in the system. It can be seen that the output does not oscillate much and it is found that the overshoot value is almost 50% lower compared to the conventional PID controller, as illustrated in Figure 10. However the settling time of this controller is almost 70% higher than the conventional controller. Table 5 shows the comparison between PID and BFOA in terms of performance parameters.

Table 5 : Performance Parameters of PID and BFOA.

Method	Rise Time	Settling Time	OS (%)	Peak
Experienced Personnel	0.0121	5.27	50.2	1.5
Trial and Error	0.0012	0.836	35.8	1.36
BFOA	4.92	37.4	25.7	1.26

As for the controller parameters' value, it is shown in Table 6.

Table 6 : Controller Parameters of PID and BFOA.

Method	Kp	Ki	Kd
Experienced Personnel	10	5	0.4
Trial and Error	10	50	0.8
BFOA	1.2499e-6	1.0215e-7	2.2442e-8

Depending on the priority of performance parameters taken, BFOA is still a very good controller when overshoot percentage value is given the first priority.

CHAPTER 5

CONCLUSION

In this project, various techniques used to implement in Magnetic Levitation System is discussed and compared in order to find the most suitable algorithm which can improve the Magnetic Levitation System in terms of its performance. The mathematical model of Ball Magnetic Levitation System is produced. Bacterial Foraging Optimization Algorithm (BFOA) has been chosen to be implemented in the system in order to optimize the PID controller parameters. The results were compared and observed between the conventional PID controller and BFOA. It is observed that BFOA has good performance in terms of overshoot percentage value but poor settling time. However, it is important to remember that unlike PID which requires experience personnel, BFOA saves the time and cost in optimizing the controller parameters.

Besides that, this project has awarded a silver medal in Science and Engineering Design Exhibition (SEDEX) in April 2012. The copy of the certificate obtained is in **Appendix C**.

Further studies can be done to modify the BFOA controller for Magnetic Levitation System in order to obtain good performance in both overshoot percentage value and settling time. This is essential as application of Magnetic Levitation System is growing rapidly in semiconductor industry, transport, household appliances, power generator, educational field and etc.

REFERENCES

- [1] http://en.wikipedia.org/wiki/Magnetic_levitation
- [2] A.K. Ahmad; Z. Saad; M.K Osman; I.S Isa; S. Sadimin, "Control of Magnetic Levitation System using Fuzzy Logic Control", *IEEE Journals*, 2010.
- [3] Jen-Hsing Li, "Fuzzy PD Type Control of Magnetic Levitation System", *IEEE Journals*, 2010.
- [4] Kashif Ishaque, Yasir Saleem, S.S Abdullah, M. Amjad, Munaf Rashid and Suhail Kazi, "Modeling and Control of Magnetic Levitation System via fuzzy Logic Controller", *IEEE Journals*, 2011.
- [5] Jie Ma, Wenjun Fan, Fenghua He, "Parameters Self-adjusting Fuzzy PID Control in Magnetic Levitation System", *IEEE Journals*, 2008.
- [6] Ji-Hyuk Yang, Young-Sam Lee and Oh-Kyu Kwon, "Development of Magnetic Force Modeling Equipment for Magnetic Levitation System", *IEEE Journals*, 2010.
- [7] Meiyung Chen, Ming-Jyh Wang and Li-Chen Fu. "Modeling and controller design of a maglev guiding system for application in precision positioning, " *IEEE Transactions on Industrial Electronics* vol.50, no.3, pp.493-506, June 2003.
- [8] Walter Barie; John Chiasson , Linear and nonlinear state-space controllers for magnetic levitation , *International Journal of System Science*, Volume 27, Issue 11 November 1996, Pages 1153-1163.
- [9] Cho, D.; Kato, Y.; Spilman, D., "Sliding-Mode Controller and Classical Controller on Magnetic Levitation System", *Control System Magazine, IEEE*, 1993, Volume 13, Page 42-48.
- [10] Chen Wenbai, Meng Xuan, Li Jinao, "PID Controller Design of Maglev Ball System Based on Chaos Parameter Optimization", *International Conference on Machine Vision and Human-Machine Interface(MVHI)*, 2010, Page 772-775.
- [11] Tzu-Hseng S Li, Ming-Yuan Shieh, "Switching-type fuzzy sliding mode control of a cart±pole system", *Mechatronic Elsevier*, March 2000, Page 91-109.
- [12] CHAO-LIN KUO, TZUU-HSENG S. LI_ and NAI REN GUO (2005). "Design

of a Novel Fuzzy Sliding-Mode Control for Magnetic Ball Levitation System
“*Journal of Intelligent and Robotic Systems* 42: 295–316 © Springer 2005.

- [13] G. Cho, Y. Kato and D. Spilman, “Sliding mode and classical controllers in magnetic levitation system,” *IEEE Control System Magazine*, vol.13, pp. 42-48, 1993.
- [14] J. Phuah, J. Lu and T. Yahagi, “Chattering Free Sliding Mode Control in Magnetic Levitation System,” *IEEJ Trans. EIS*, vol. 125, no. 4, pp. 600-606, 2005.
- [15] M. Shafiq and S. Akhtar, “Inverse Model Based Adaptive Control of Magnetic Levitation System,” *The Proc. of the 5th Asian Control Conference*, 2004.
- [16] Z. J. Yang, K. Miyazaki, S. Kanae, and K. Wada, “Robust Position Control of a Magnetic Levitation System via Dynamic Surface Control Technique” *IEEE Trans on Industrial Elect*, vol. 51, no. 1, pp. 26-34, 2004.
- [17] K.J. astrom and T. Hagglund, *PID Controllers: Theory Design and Tuning (2nd Edition)*, Research Triangle Park, NC, ISA, 1995.
- [18] K.H. Ang, G. Chong and Y. Li, “PID Control System Analysis, Design and Technology”, *IEEE Trans. On Control System Technology*, vol. 13, no. 4, pp. 559-576, 2005.
- [19] B. Hu, K. I. Mann and R. G Gosine “New Methodology for Analytical and Optimal Design of Fuzzy PID Controllers”, “*IEEE Trans. on Fuzzy System*”, vol. 7, no. 5, pp. 521-538, 1999.
- [20] G.K. I. Mann, B.G. Hu, and R.G. Gosine, “Analysis of Direct Action Cybernetics,” vol. 29, no. 3, ppl. 371-388, June 1999.
- [21] Agus Trisanto, Muhammad Yasser, Jianming Lu, and Takashi Yahagi, “Implementation of a Fuzzy PID Controller using Neural Network on the Magnetic Levitation System”, *IEEE Journals*, 2006.
- [22] Jinkun Liu, *Advanced PID Control and Matlab Simulation*, Publishing House of Electronics Industry, Beijing, 2004.
- [23] Yang Xue and Zhenjie Yan, “Research on RBF Tuning PID and Fuzzy Immune Control System of Superheat Temperature,” 2010 Sixth International Conference on Natural Computation, pp. 3528-3531, 2010.
- [24] Changlu Zheng, Jian Fan, Minrui Fei and Zhinian Gao, “RBF Control Research based on Fuzzy Neural Model,” *Computational Intelligence and Software Engineering*, pp. 1-3, 2009.
- [25] Lixin Xing, Shanqing Gao and Yunfei Chen, “A Novel Control Method based on Fuzzy Neural Network,” 2009 International Conference of Computational Intelligence and Security, pp. 237-239, 2009.

- [26] Lei Ouyang, Yourui Huang and Yiqing Huang, "PID Controller Based on Fuzzy RBF Neural Network and Its Application", *Computer Engineering*, vol. 34, no.22, pp. 231-233, 2008.
- [27] D. K. Cheng, *Field and Wave Electromagnetics*. MA: Addison-Wesley, 1983.
- [28] A. Smaili and F. Mrad, *Applied Mechatronics*. MA: Oxford, 2008.
- [29] http://en.wikipedia.org/wiki/PID_controller
- [30] Swagatam Das, Arijit Biswas, Sambarta Dasgupta and Ajith Abraham, "Bacteria Foraging Optimization Algorithm: Theoretical Foundations, Analysis and Applications", Dept. of Electronics and Telecommunication Engg, Jadavpur University, Kolkata, India; Norwegian University of Science and Technology, Norway.

APPENDICES

APPENDIX A
DIFFERENT TECHNIQUES USED IN MAGLEV

	Journal	Author(s)	Date Published	Pros & Cons	Notes
1	Linear & Nonlinear State-space Controllers for Magnetic Levitation	Walter Bariet; John Chiasson	1996	Position tracking error of system oscillate at about $\pm 0.45\text{mm}$.	Use nonlinear state-space transformation along with nonlinear state feedback to linearize the system.
2	Sliding-mode Controller & Classical Controller on Magnetic Levitation System	Cho, D; Kato, Y; Spilman, D.	1993	Solve parameter uncertainties issue; reject disturbances to achieve robust performance.	Apply sliding mode control (SMC) in magnetic levitation system.
3	PID Controller Design of Maglev Ball System based on Parameters Optimization	Chen Wenbai; Meng Xuan; Li Jinao	2010	<ul style="list-style-type: none"> - Compensates effects of the non-modeled linearity. - Enables certain system to be stabilized close to their nominal operating point. - Robust & reliable system if PID parameters are determined. <p>Helps in tuning/setting of PID parameters.</p>	<p>Apply PID controller.</p> <p>Apply Chaos Optimization.</p>
4	Switching-type Fuzzy Sliding Mode Control of a Cart $\pm pole$ system	Tzu-Hseng S. Li; Ming-Yuan Shieh	2000	Achieve the asymptotic stability of the system and systems of controlled object do not have to be known in detail.	Apply Fuzzy Sliding Mode Controller (FSMC).
5	Design of a Novel Fuzzy Sliding-Mode Control for	Chao-Lin Kuo; Tzuo-Hseng S. Li; Nai Ren Guo	2005	Better performance in terms of IAE & ISV.	Apply Novel Fuzzy Sliding-Mode Control (NFSMC).

	Magnetic Ball Levitation System				
6	<p>a. Sliding Mode & Classical Controllers in Magnetic Levitation System</p> <p>b. Chattering Free Sliding Mode Control in Magnetic Levitation System</p> <p>c. Inverse Model based Adaptive Control of Magnetic Levitation System</p> <p>d. Robust Position Control of a Magnetic Levitation System via Dynamic Surface Control Technique</p>	<p>a. G. Cho, Y. Kato & D. Spilman;</p> <p>b. J. Phuah, J. Lu & T. Yahagi;</p> <p>c. M. Shafiq & S. Akhtar</p> <p>d. Z. J. Yang, K. Miyazaki, S. Kanae, K. Wads;</p>	<p>1993</p> <p>2005</p> <p>2004</p> <p>2004</p>	<p>- Mathematical model for the controlled plant & its disturbances need to be developed and regulator parameters for some control design need to be derived.</p> <p>- Such procedures will consume a lot of time and requires skillful personnel in modeling, system identification and control design.</p>	<p>Apply Sliding-mode control, inverse model based adaptive control & robust positive control for contributing the Magnetic Levitation System.</p>
7	Implementation of a Fuzzy PID Controller using Neural Network on the Magnetic Levitation System	Agus Trisanto, Muhammad Yasser, Jianming Lu, Takashi Yahagi	2006	Compensates incorrectly selection of parameter gains of FPID.	Apply Neural Network in control system of FPID.

APPENDIX B

GANTT CHART / KEY MILESTONE

Key Milestone

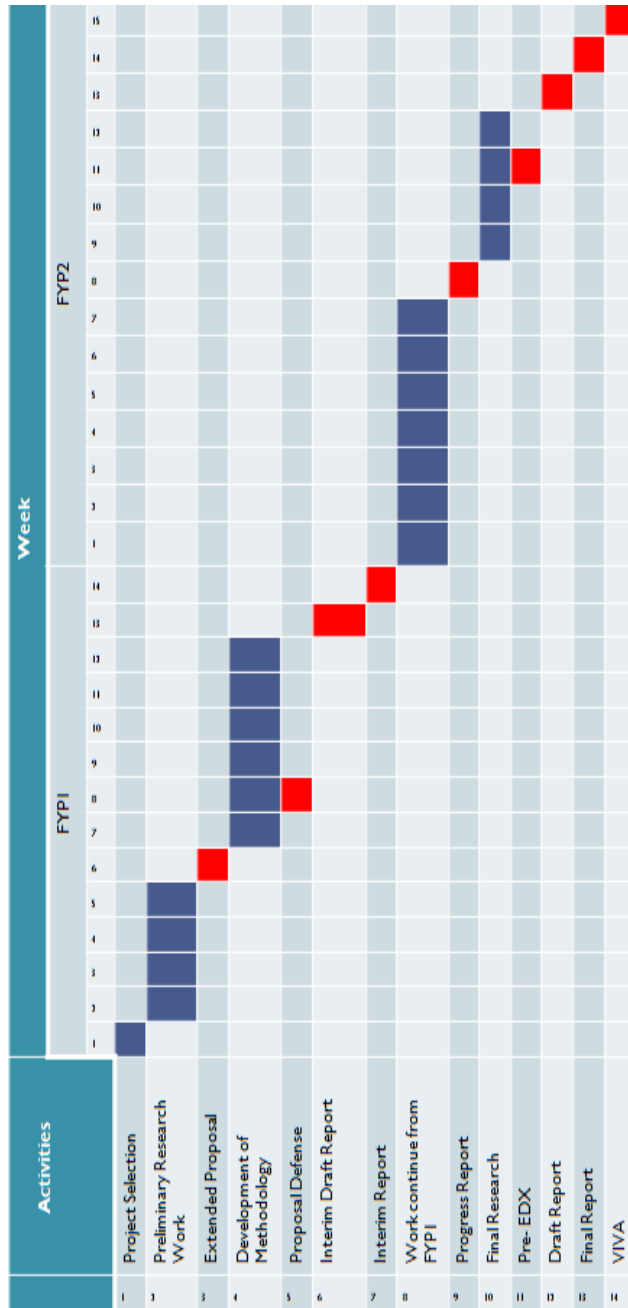

APPENDIX C
CERTIFICATE OF SCIENCE AND ENGINEERING DESIGN
EXHIBITION (SEDEX)

