

**SINGLE PHASE TO THREE PHASE CONVERTER FOR VARIABLE SPEED  
DRIVE APPLICATIONS**

By

NORINA BINTI KIFFLI

FINAL PROJECT REPORT

Submitted to the Department of Electrical & Electronic Engineering  
in Partial Fulfillment of the Requirements  
for the Degree  
Bachelor of Engineering (Hons)  
(Electrical & Electronic Engineering)

Universiti Teknologi PETRONAS  
Bandar Seri Iskandar  
31750 Tronoh  
Perak Darul Ridzuan

© Copyright 2012

by

Norina Kiffli, 2012

# **CERTIFICATION OF APPROVAL**

## **SINGLE PHASE TO THREE PHASE APPLICATIONS FOR VARIABLE SPEED DRIVE APPLICATIONS**

by

Norina binti Kiffli

A project dissertation submitted to the  
Department of Electrical & Electronic Engineering  
Universiti Teknologi PETRONAS  
in partial fulfilment of the requirement for the  
Bachelor of Engineering (Hons)  
(Electrical & Electronic Engineering)

Approved:



---

AP Dr. Nordin Saad  
Project Supervisor

UNIVERSITI TEKNOLOGI PETRONAS  
TRONOH, PERAK

September 2012

## CERTIFICATION OF ORIGINALITY

This is to certify that I am responsible for the work submitted in this project, that the original work is my own except as specified in the references and acknowledgements, and that the original work contained herein have not been undertaken or done by unspecified sources or persons.



---

Norina Kiffli

## **ABSTRACT**

This final report is mainly to give an overview about the “Single phase to Three phase converter for variable speed drive applications” project and also the progress of the project. Due to unavailability and high cost installation of three phase power network, power inverter is very important to address this problem. Here comes the purpose of the project to develop electronic converters that applicable for three phase equipment that equipped with variable speed drive (VSD) applications to operate in single phase supply. This project proposed two converter topologies for circuit modelling and simulation. There are PRC and PWM method. The modeling for the project will be done using PSPICE software. The model will be simulating based on the load requirement which is 3-phase motor for the converter design. Based on the simulation analysis it has been proved that these two methods can be implemented in order to achieve the project’s objective which to produce 3 phase power from single phase supply with improved performance and better efficiency. For this given time frame the project only focus on the methodology on how to develop the converter using proposed method but without control strategy. Further improvement or works can be carried out to improve the design by implemented control strategy for the converter.

## **ACKNOWLEDGEMENTS**

First and foremost, praise to Allah the Almighty for giving me strength and enthusiasm to undergo my 5 years period of study at this beloved Universiti Teknologi PETRONAS. Without Him, I am sure I would not have made it this far. Special acknowledgements are owned to my beloved family and friends for giving me the support and inspiration.

My sincere and heartfelt thanks to the FYP Supervisor AP Dr. Nordin Saad for his enlightening supervision and countless hours spent in sharing his insightful understanding, profound knowledge and valuable experiences throughout the completion of my final year project. I also would like to express my full appreciation for all his guidance throughout these two semesters.

Loads of thanks to FYP coordinator for providing me sufficient and useful guidelines and lending an effortless compassionate help so that I can complete my final year project successfully and within the given time frame.

My thanks also go to all Electrical & Electronic Engineering Department staffs that were so helpful and their never-ending supports to complete my final year project. The experience in doing this final year project will be a memorable and an encouraging one in my life experience. Last but not least, to all my colleagues that has directly or indirectly lend their helping hands, thank you so much.

## TABLE OF CONTENTS

LIST OF TABLES .....	ix
LIST OF FIGURES .....	x
LIST OF ABBREVIATIONS .....	xii
CHAPTER 1 INTRODUCTION.....	1
1.1 Background Study.....	1
1.2 Problem Statement .....	2
1.3 Objectives .....	3
1.4 Scope of study.....	3
1.4.1 Parallel Resonant Converter (PRC) and Pulse Width Method (PWM) method.....	3
1.4.2 Designing single phase to three phase converter.....	3
1.4.3 Modelling and simulation using PSPICE.....	4
1.5 Feasibility of the project.....	4
1.6 Relevancy of the project.....	4
CHAPTER 2 LITERATURE REVIEW .....	5
2.1 Overview of world energy.....	5
2.2 Overview of Variable Speed Drive Technology.....	6
2.3 VSD as energy saving efficiency .....	7
2.4 Single Phase to Three Phase system .....	8
2.5 Converter Algorithm .....	9
2.5.1 Pulse Width Modulation Inverter .....	9
2.5.2 Parallel Resonant Converter .....	11
2.6 IGBT and Power MOSFET's .....	13
2.6.1 Insulated Gate Bipolar Transistor (IGBT) .....	13
2.6.2 Power MOSFET .....	14
2.7 Renewable Energy .....	15
2.7.1 Wind Energy.....	15
2.7.2 Tidal Energy .....	15
2.8 Portable Single Phase to Three Phase Converter.....	16
CHAPTER 3 METHODOLOGY.....	17
3.1 Research Methodology.....	17

3.2 Work Flow .....	17
3.3 Flow Chart and FYP timeline .....	18
3.4 Tool required.....	18
CHAPTER 4 RESULT AND DISCUSSION .....	19
4.1 Design Specification .....	19
4.2 Design configuration .....	19
4.3 Converter Design and simulation analysis .....	21
4.3.1 Parallel resonant tank component .....	21
4.3.1.1 Circuit configuration.....	22
4.3.1.2 Simulation analysis.....	23
4.3.2 Switching circuit analysis.....	24
4.3.3 Parallel loaded resonant converter .....	28
4.3.4 Output filter component .....	33
4.3.5 The Six-step Inverter.....	35
4.3.5.1 Switching parameters.....	36
4.3.6 Complete Circuit Configuration.....	40
CHAPTER 5 CONCLUSION.....	41
REFERENCES.....	42
APPENDICES.....	45
Appendix A.....	46
Appendix B FYP TIMELINE.....	47

## LIST OF TABLES

Table 1 Savings potential for motor systems in the EU is over 200 billion kWh annually.....	7
Table 2 Voltage across capacitor and current through resonant inductor.....	24
Table 3: Design specification on MOSFET.....	24
Table 4: Losses for circuit condition of 50 KHz.....	28
Table 5: Four topological mode in PRC.....	30
Table 6: Input Voltage and corresponding switching frequency.....	32
Table 7: The switching parameter for all six MOSFET.....	36
Table 8: Fourier component for six-step inverter.....	39

## LIST OF FIGURES

Figure 1 World Energy Consumption, 1973-2005.....	6
Figure 2 Conventional VSD configuration.....	7
Figure 3: Gross saving for 15-yr variable speed drives.....	8
Figure 4: Typical single phase to three phase circuit converter.....	10
Figure 5: Example of typical Full bridge parallel resonant converter circuit.....	12
Figure 6: Example of typical waveforms for the parallel resonant converter operating in continuous conduction mode.....	12
Figure 7: Comparison between hard switching and resonant switching in term of losses.....	13
Figure 8: Equivalent circuit of MOSFET.....	14
Figure 9: Work flow for FYP.....	17
Figure 10: Conventional VSD Design.....	19
Figure 11: Proposed Project Design.....	20
Figure 12: Simple circuit design.....	22
Figure 13: Circuit design with switching device implementation.....	22
Figure 14: Output for circuit in figure 12.....	23
Figure 15: Output for circuit in figure 13.....	23
Figure 16: Lossless switching.....	25
Figure 17: Current switching.....	26
Figure 17: State transition between $V_a$ & $V_b$ .....	26
Figure 18: Turn on Lossless switching.....	27
Figure 19: Switching losses formula .....	28
Figure 20: Extended version of parallel resonant converter circuit.....	29
Figure 21: Equivalent circuit of PRC.....	30
Figure 22: Four topological mode in PRC.....	30
Figure 23: Waveform for PRC above resonant.....	31
Figure 24: Waveform for PRC below resonant.....	31
Figure 25: Graph of frequency versus output voltage.....	32
Figure 26: The output waveform of 100V.....	33
Figure 27: Circuit diagram.....	35
Figure 28: Switching sequence for six-step output.....	36

Figure 29: Line to line output voltages.....37  
Figure 30: Line to neutral voltages for an ungrounded Y-connected circuit.....37  
Figure 31: Current in Phase A, B & C.....38  
Figure 32: Complete circuit configuration.....40

## **LIST OF ABBREVIATIONS**

VSD	Variable Speed Drives
PWM	Pulse Width Modulation
PRC	Parallel Resonant Converter
MOSFET	Metal Oxide Silicon Field Effect Transistor
IGBT	Insulated Gate Bipolar Transistor
THD	Total Harmonic Distortion
IEA	International Energy Agency
IPCC	Intergovernmental Panel on Climate Change

# CHAPTER 1

## INTRODUCTION

### 1.1 Background Study

Today AC motor drives are widely used in various domestic and industrial applications. It has been realized that three phase electrical equipment is such as three-phase induction motors are more efficient, economical and easy to control. While single phase motors tend to have lower performance and higher cost compare to three phase motor [1]. The three phase motors are generally found for high power requirements like power drives for compressors, hydraulic pumps, air conditioning compressors, irrigation pumps and many more. A three-phase induction motor also has a simple design, inherently high starting torque and high efficiency. Such motors are applied in industry for pumps, fans, blowers, compressors, conveyor drives, electric vehicles and many other kinds of motor-driven equipment. But most of them are often used without speed control and only about <10% are equipped with speed control application.

Variable Speed drives (VSD) are used to provide precise speed and torque control of three-phase motors. Some models can be powered by a single-phase supply. But most application is using three-phase power. The objective of this project is to design the converter to drive this motor where three phase power is not available. VSD works by converting the supply voltage to DC and then converting the DC to a suitable three-phase source for the motor. This device is used to control the speed of conveyor systems, blower speeds, pump speeds, machine tool speeds, and other applications that require variable speed with variable torque. The complete system consists of an ac voltage input that is put through a diode bridge rectifier to produce a dc output which across a shunt capacitor, this will, in turn, feed the PWM inverter. The PWM inverter is controlled to produce a desired sinusoidal voltage at a particular frequency,

which is filtered by the use of an inductor in series and capacitor in parallel and then through to the squirrel cage induction motor. Most industrial and domestic applications preferred to use three phase motor because it has many advantages.

The factors that influence the choice of three-phase motor are listed as follows [2]:

- a. Three-phase motors are significantly more efficient and economical than their single-phase counterparts.
- b. Starting and inrush currents in a three-phase motor are less severe than in a single-phase motor.
- c. Easy to control than single phase

## **1.2 Problem Statement**

In view of the machine efficiency, power factor, and torque ripples, a three-phase induction motor is preferable to a single-phase induction motor [3]. However, not all places are fed with three phase power network to power the motor. According to power distribution network, power plant generation only supplied 3 phase power to heavy industrial load. In the places where only a single-phase utility is available, a single-phase to three-phase power converter system is required to feed the three-phase induction motor drives. Some applications also are only able to work with three phase power rather than single phase power. This is where the portable converter is needed in order to operate the machine.

The other concern issue is cost installation. Basically the cost of installing three-phase power is often high due to high cost for a three-phase extension. Furthermore, the rate structure of a three-phase service is higher than that for single-phase service. By having this converter the cost can be reduce. Hence not all appliances and machines are using three phase power network. It is not reliable to install 3 phase network just to power up one machine while other appliances are only applicable using single phase power network.

According to European Commission, about 65% to 70% consumed electrical energy are from the usage of electric motor [4]. Most of them run without speed control meaning that most of the time the motor run without speed control. Power consumed is directly proportional to cube of speed. Higher speed will lead to higher power consumed. Regardless the process condition whether require high speed or low speed, motor without speed control will continuously run at full speed. From that we can see there is electrical energy wasted through the motor. As the world today try hard to save the energy by producing energy-saving technologies. Many research have been done and it has been proved that VSD is one of the solution and very efficient in energy saving.

### **1.3 Objectives**

The main objective of this project is to design and simulate single phase to three phase converter model for variable speed drive application using PSPICE software. The sub objective of the second part of the project is to construct the design using PSPICE and testing the model by circuit simulation using PSPICE software.

### **1.4 Scope of study**

There many theoretical knowledge that the author need to understand in order to complete this project.

#### ***1.4.1 Parallel Resonant Converter (PRC) and Pulse Width Modulation (PWM) method.***

The author needs to understand the basic fundamental and relevance theory of both PRC and PWM method by doing some research on papers/journals, books and etc.

#### ***1.4.2 Designing single phase to three phase converter***

Based on the research review on selected reference papers, the author needs to proposed suitable method for designing the converter.

### ***1.4.3 Modelling and simulation using PSPICE***

The author needs to familiarize with PSPICE software for developing the circuit design and simulation analysis on the design.

### **1.5 Feasibility of the project**

The project will be done in two semesters which include three areas which are research, development and also the design of the model itself. PSPICE will be used as the tools to develop and simulate the converter design. System testing and implementation will also be done using this software. Based on the description above it is very clear that this project will be feasible to be carried out within the time frame.

### **1.6 Relevancy of the project**

This project is relevant to the current situation where many researches and studies are on their way to find alternatives for energy saving efficiency solution to meet the world demand of reducing gas emission through energy saving. Furthermore, the increase demand in electrical motor in market especially for domestic used where only single phase power is available gives more reasons for this project to be proceeding. The load application for this project is three-phase motor. In term of durability, three-phase motors also vibrate less and hence last longer than single-phase motors of the same power used under the same conditions. Hence, a three-phase motor is more compact and less costly than a single-phase motor of the same voltage class and rating and single-phase AC motors above 10 HP (7.5 kW) are uncommon. The above explanation clearly stated the need of this project to be proceeding as the solution for the problems.

## **CHAPTER 2**

### **LITERATURE REVIEW**

#### **2.1 Overview of world energy**

In today's world, the demand for energy is increasing at all parts of the globe. *World* energy consumption has been rising steadily. The International Energy Agency (IEA) finds in its June 2008 report that CO<sub>2</sub> emissions will grow by 130 percent and oil demand will rise by 70 percent by 2050. The IPCC (Intergovernmental Panel on Climate Change) finds in its reports that increasing levels of carbon dioxide lead to atmospheric warming. This global warming may also cause increasing in ocean temperatures, widespread melting of snow and ice, and rising global average sea level. The effective ways to overcome this issue is to reduce CO<sub>2</sub> emissions, cheaply, quickly and efficiently. One answer is to use energy more efficiently. That is why energy saving efficiency is very important. Similarly in industry, the biggest reductions in emissions in the short term will come from measures to run processes more efficiently. About 40 percent of electricity is consumed by industry, and two-thirds of that is used by electric motors. Variable speed drives (VSDs), which regulate the speed of a motor, can reduce their energy consumption by 50 percent in many applications. Yet less than 10 percent of motors are equipped with such a device. Energy saving is without doubt the quickest, most effective and most cost-effective manner for reducing greenhouse gas emissions, as well as improving air quality [5].

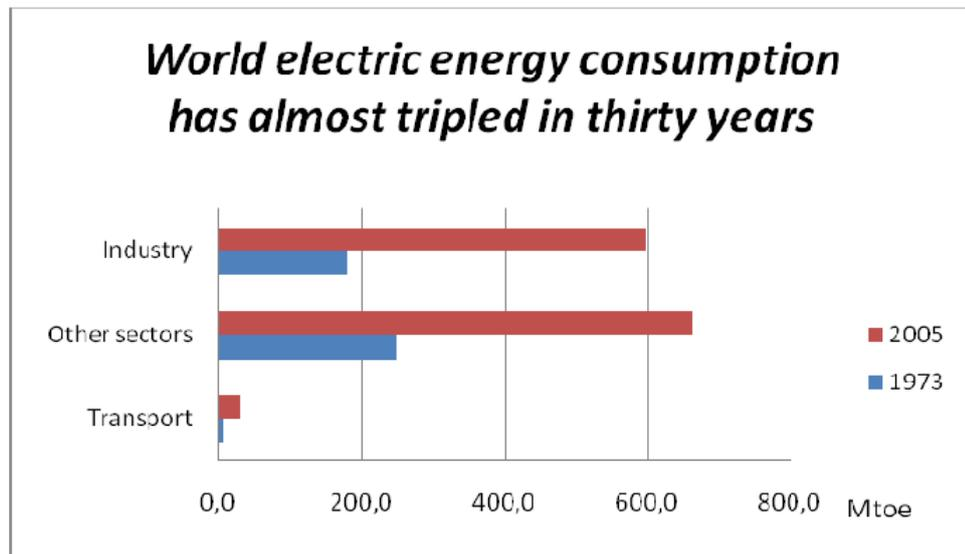

Figure 1: World Energy Consumption, 1973-2005

Source : International Energy Agency, Key World Energy Statistics 2007

## 2.2 Overview of Variable Speed Drive Technology

Variable speed drive technology has been widely applied in various industrial applications for the last few decades. Variable speed drive (VSD) is a device that controls the speed of motor or the equipment driven by the motor. VSD is used in machine such as compressors, machine tools, fans, pumps, etc. The advance technology in microelectronics and development in AC motor control techniques are enabling rapid growth in VSD application. The device will control the speed of the machine by converting the fixed voltage and frequency to adjustable values on the machine side. There are many types of converters available for this purpose with different method of application. They are classified according to number of phases, use of power semiconductor devices, commutation principles, and output waveforms [6].

There are many advantages of why people choose VSD in motor applications. VSD application is the most effective ways of energy savings for variable-load and variable speed applications when compared with other conventional technologies. It operates at maximum efficiency control, aimed at current torque ratio minimization, and to reduce the losses. This development allowed miniaturization of the motor, saving material resources in the construction. It also contributes to the energy saving as a

result of its smaller size and lighter weight [7]. They also enhance process operations, particularly where flow control is involved. VSDs provide soft-start capabilities, which decrease electrical stresses and line voltage sags associated with full voltage motor start-ups, especially when driving high-inertia loads.

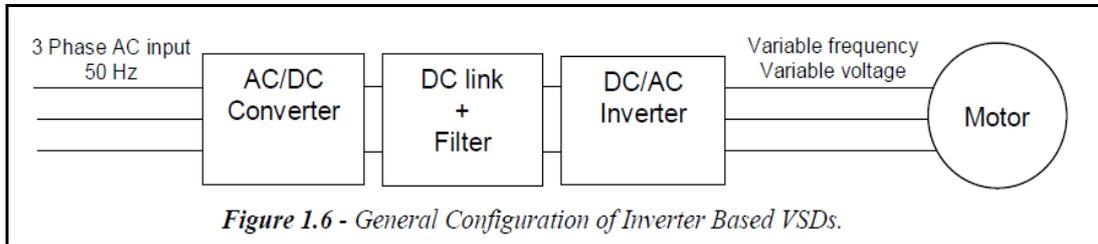

Figure 2: Conventional VSD configuration

Figure above shows conventional VSD application that widely used in most industrial applications.

### 2.3 VSD as energy saving efficiency

Energy efficient motor driven systems would save billion of kWh [5]. It has been proved in the table below;

	Savings potential (billion kWh/year)					
	EU-15	EU-25	France	Germany	Italy	UK
High efficiency motors	24	27	4	6	4	3
Variable speed drives	45	50	8	10	7	6
Application part of the motor systems (pumps, fans, compressors)	112	125	19	26	17	15
Total electricity savings potential	181	202	31	42	28	24

**Table 1 :** Savings potential for motor systems in the EU is over 200 billion kWh annually

*Source: Energy Efficient Motor Driven Systems, The Motor Challenge Programme*

Efficient speed control with variable speed drives is one of the solutions for energy saving as it provides lower energy consumption [6]-[8]. Today the efforts to save energy in refineries and petrochemicals plants are being done both thermally and electrically to save energy. As electrical power costs continue to rise, more and more

attention is being paid to saving electrical losses, principally by turning to cogeneration, more efficient distribution equipment, high-efficiency motors, and variable speed drives [9]. Variable speed saves energy in several different ways;

- Savings in driver
- Savings in driven equipment (fan, pump, compressor, blowers)
- Potential fringe benefits exists in one or more features in variable speed drives

Figure below shows the different between fixed speed and variable speed motor performance with same rating.

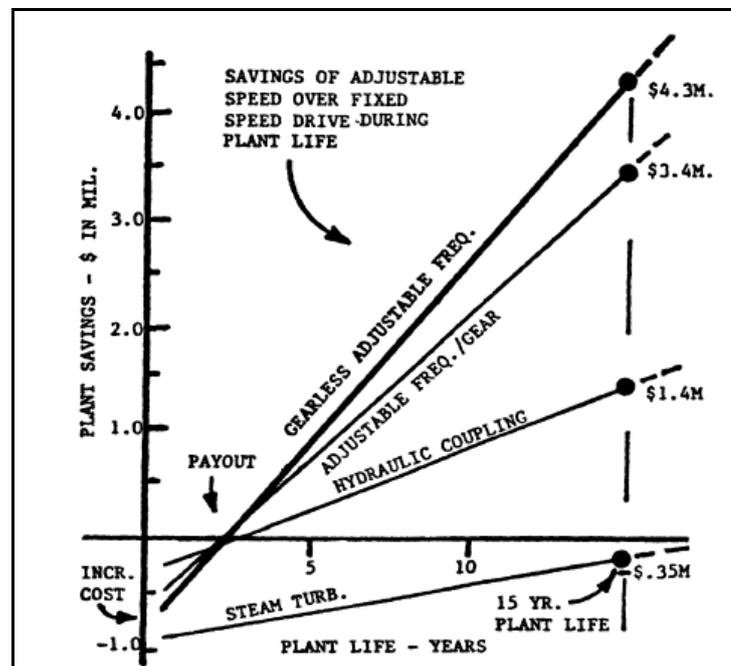

Figure 3: Gross saving for 15-yr variable speed drives

## 2.4 Single Phase to Three Phase system

Single-phase power distribution is widely used especially in remote areas, where the cost of a three-phase distribution network is high and motor loads are small and uncommon. A three-phase system is generally more economical than others because it uses less conductor material to transmit electric power than equivalent single-phase or two-phase systems at the same voltage.

Three-phase has properties that make it very desirable in electric power systems:

- The phase currents tend to cancel out one another, summing to zero in the case of a linear balanced load. This makes it possible to eliminate or reduce the size of the neutral conductor; all the phase conductors carry the same current and so can be the same size, for a balanced load.
- Power transfer into a linear balanced load is constant, which helps to reduce generator and motor vibrations.
- Three-phase systems can produce a magnetic field that rotates in a specified direction, which simplifies the design of electric motors.
- Because single-phase power goes to zero at each moment that the voltage crosses zero but three-phase delivers power continuously, any such converter must have a way to store energy for the necessary fraction of a second.

## **2.5 Converter Algorithm**

Single phase to three phase converters are used to drive three phase machine usually induction motors. The machine is fed from the single phase supplies. This type of converter is needed especially in remote area like farm or home industries where only single phase power is available to drive the three phase machine.

### ***2.5.1 Pulse Width Modulation Inverter***

In this project the conversion is made using PWM inverter. The term "pulse width modulation" (PWM) explains how each transition of the alternating voltage output is actually a series of short pulses of varying widths. By varying the width of the pulses in each half cycle, the average power produced has a sine-like output. The number of transitions from positive to negative per second determines the actual frequency to the motor. PWM also used to keep the output voltage of the inverter at the rated voltage [10]-[11]. PWM inverter has the following advantages:

- Excellent input power factor due to fixed DC bus voltage.
- No motor cogging normally found with six-step inverters.
- Highest efficiencies: 92% to 96%.
- Compatibility with multi motor applications.

- Ability to ride through a 3 to 5 Hz power loss.
- Lower initial cost.

However there are disadvantages that should consider when choosing this method where motor heating and insulation breakdown may occur in some applications due to high frequency switching of transistors.

There are many PWM techniques exist in converter applications. Below are examples introduced by some researchers [12];

- Switching at the intersection of a target reference waveform and a high frequency triangular carrier.
- Switching at the intersection between a regularly sampled reference waveform and a high frequency triangular carrier.
- Switching so that the amplitude and phase of the target reference expressed as a vector is the same as the integrated area of the converter switched output over the carrier interval

The conventional sinusoidal PWM converter circuit is useful to get high quality characteristics about the current waveform, the power factor and bidirectional functions [13]-[14].

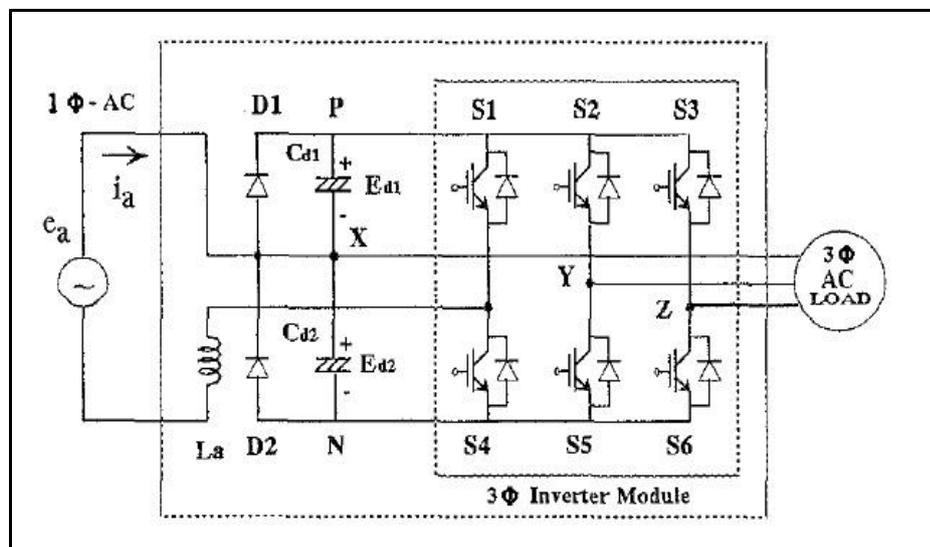

Figure 4: Typical single phase to three phase circuit converter

Figure above is an example of converter circuit with PWM converter. This circuit is constructed with two power inverters. The one leg switching devices is used for a single half bridge converter and remained two switching devices are the 3-phase power inverter.

### ***2.5.2 Parallel Resonant Converter***

Resonant converters use a resonant circuit for switching the transistors when they are at the zero current or zero voltage point which will reduce the stress on the switching transistors [15]. The output voltage is controls with resonant converters are driven with constant pulse duration at a variable frequency. The pulse duration is required to be equal to half of the resonant period time for switching at the zero-crossing points of current or voltage. Parallel resonant inverter can be obtained by controlling the ac loads of two identical parallel resonant inverters [16]-[17]. A phase shift between the drive signals of the two inverters control the amplitude and output voltage of the new inverter. A voltage-driven rectifier is used as an ac load of the inverter. For applied frequency higher than resonant frequency by a factor of 1.07 the load of each switching leg is inductive. This is suitable for power MOSFET switches application [18].

Parallel Resonant Converter is operating at continuous conduction mode [19]. A full bridge isolated version of the parallel resonant converter is given in Figure 2. The converter differs from the series resonant converter because it is the tank capacitor voltage, rather than the tank inductor current, which is rectified and filtered to produce the dc load voltage. A two-pole L-C low pass filter (LF and CF) performs this filter function. The magnitude of the quasi-sinusoidal voltage  $V_C(t)$  is controllable by variation of the switching frequency ( $V_c$ ) and becomes large in amplitude near resonance. Hence, the dc output voltage  $V$  is controllable by variation of the normalized switching frequency  $F = f_S / f_0$ .

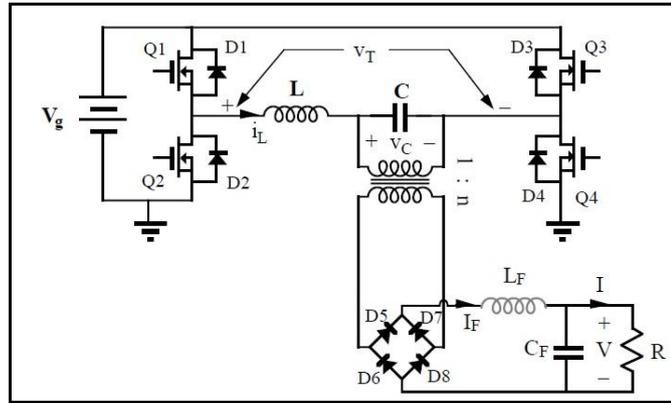

Figure 5: Example of typical Full bridge parallel resonant converter circuit

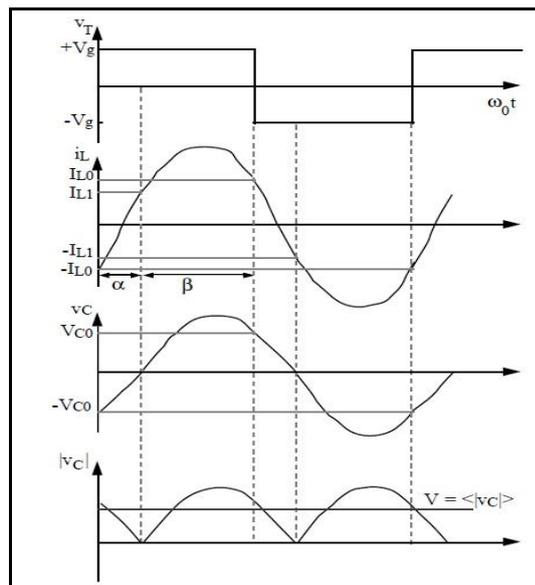

Figure 6: Example of typical waveforms for the parallel resonant converter operating in continuous conduction mode.

The advantages of resonant converter are:

- Can be used to increase circuit switching speeds
- Allowing the cost of circuit magnetic to be reduced
- Keeping switching losses to a minimum

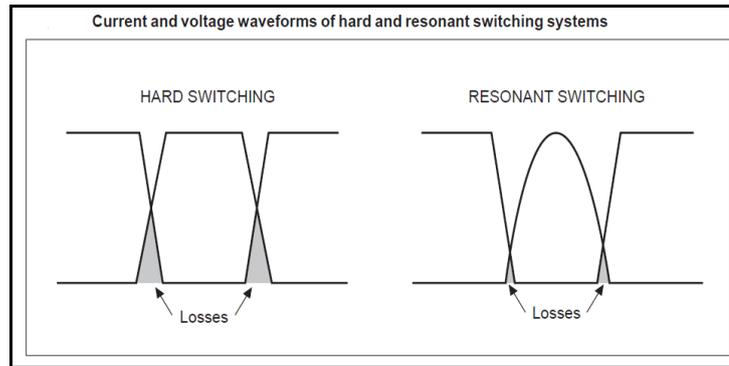

Figure 7: Comparison between hard switching and resonant switching in term of losses.

## 2.6 IGBT and Power MOSFET's

In the process of designing the converter there are two possible semiconductor devices that can be use either MOSFET or IGBT. These two devices have its own characteristics and the choice is depends on the converter design itself. This project is using power MOSFET as the switching component.

### 2.6.1 *Insulated Gate Bipolar Transistor (IGBT)*

The insulated-gate bipolar transistor (IGBT) is a three-terminal power semiconductor device, used for high efficiency and fast switching. It switches electric power in many modern appliances such as electric cars, variable speed refrigerators, air-conditioners, etc. The IGBT is usually a cross between the bipolar (BJT) and MOSFET transistors. The IGBT has the output switching and conduction characteristics of a bipolar transistor but is voltage-controlled like a MOSFET [14].

IGBTs are preferred device under these conditions:

- Low frequency (<20kHz)
- Low duty cycle
- Narrow or small line or load variations
- High-voltage applications (>1000V)
- Operation at high junction temperature is allowed (>100 ° C)
- >5kW output power

Typical IGBT applications include:

- Motor control: Frequency  $<20\text{kHz}$ , short circuit/in-rush limit protection
- Uninterruptible power supply (UPS): Constant load, typically low frequency
- Welding: High average current, low frequency ( $<50\text{kHz}$ ), ZVS circuitry
- Low-power lighting: Low frequency ( $<100\text{kHz}$ )

### 2.6.2 Power MOSFET

MOSFET is a device that is voltage-controlled and not current-controlled. MOSFETs have a positive temperature coefficient and stopping thermal runaway. The on-state-resistance of MOSFET has no theoretical limits so on-state losses can be far lower. The MOSFET also has a body-drain diode, which is particularly useful in dealing with limited free-wheeling currents [20].

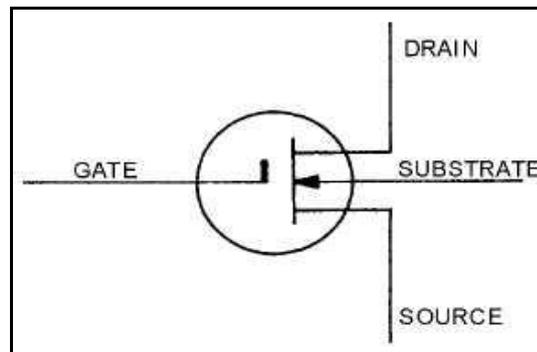

Figure 8: Equivalent circuit of MOSFET

MOSFETs are most preferred under these conditions:

- High frequency applications ( $>200\text{kHz}$ )
- Wide line or load variations
- Long duty cycles
- Low-voltage applications ( $<250\text{V}$ )
- $< 500\text{W}$  output power

Typical MOSFET applications include:

- Switch mode power supplies (SMPS): Hard switching above 200kHz
- Switch mode power supplies (SMPS): ZVS below 1000 watts
- Battery charging

## **2.7 Renewable Energy**

Renewable energy is energy which comes from natural resources such as sunlight, rain, wind and tides. Renewable energy technologies produce power, heat or mechanical energy by converting those resources to electricity. There are many power plants that producing electric power using those natural resources such as hydroelectric plant, biomass, wind energy, tidal energy and thermal energy.

### **2.7.1 Wind Energy**

Wind energy is produced from air motion caused by the uneven heating of the earth's surface by the sun. Source of energy from wind is hard to predict. Wind energy reduces environmental damage cause by gas emission and climate change due to fossil fuel replacement. Wind capacity worldwide is growing fast and may reach up to 1 million MW by 2050. This means that wind energy integration will become more important for the effects on stability of the electric grid. In this project, wind energy is used as the source supply for the load [21].

### **2.7.2 Tidal Energy**

Millions of gallons of water flow onto shore during tidal flows and away from shore during ebb tide periods. The larger the tidal influence, the greater the displacement of water and therefore the more potential energy that can be harvested during power generation. Although not yet widely used, tidal power has potential for future electricity generation. Tides are more predictable than solar power and wind energy. Tidal energy is one of many forms of hydropower generation. Tidal power has many advantages as compared to other forms of renewable energy. Global Climate Change should only increase its generating capacity due to higher ocean levels and it is completely carbon neutral like wind or hydro energy. Its main drawbacks include

higher cost of installation, limited availability for ideal sitting, and environmental impacts on local area, including flooding and ecological changes [22].

## **2.8 Portable Single Phase to Three Phase Converter**

A phase converter converts single phase electrical power into three phase power. There are many different types of phase converters. In this project our main focus is in variable speed drive application where only phase inverter type is applicable. They generally cannot be used for any type of non-motor 3 phase load. Other application such as welders, computers, battery chargers, ovens, electronics, etc. is not applicable for this type of inverter and could burn out this type of equipment if attempted to power up. Therefore they are other portable type of converter that can be used.

Rotary phase converter is when the conversion from a single phase to three phase supply has been accomplished via motor-generator sets and the most common type today. They employ bulky magnetic components of considerable size and weight. They also need frequent maintenance and must be either started or allowed to speed up before connecting a motor load to supply balanced voltages [29]. This converter is applicable to run any three phase application. There are many manufacturers that manufactured this type of converter for various applications.

Static phase converter is other type of converter that only applicable for three phase motor. There are many possible circuit topologies and configurations that static single phase to three phase converter have. One of the topology is to generate high quality fixed frequency and fixed voltage balanced three phase output using only two power semiconductor devices. The circuit complexity is minimized by using advanced pulse width modulation (PWM) techniques with high quality balanced three phase output voltages are guaranteed [29]. Static Phase Converters usually generate a three phase for only a matter of seconds during startup of electric motors, then it will drop out forcing the motor to continue to run on single phase and part of its windings.

## CHAPTER 3 METHODOLOGY

### 3.1 Research Methodology

In order to achieve the objective of this project some research need to be done. Detailed review as well as brief research about the topic is focused in the selected papers which concentrate on the single phase to three phase converter itself. The issues related between the selected paper and our project's objective need to be taken into account to ensure the credibility of this project. Besides, detailed review and some research are also carried out on several resources such as books, journal and also internet.

### 3.2 Work Flow

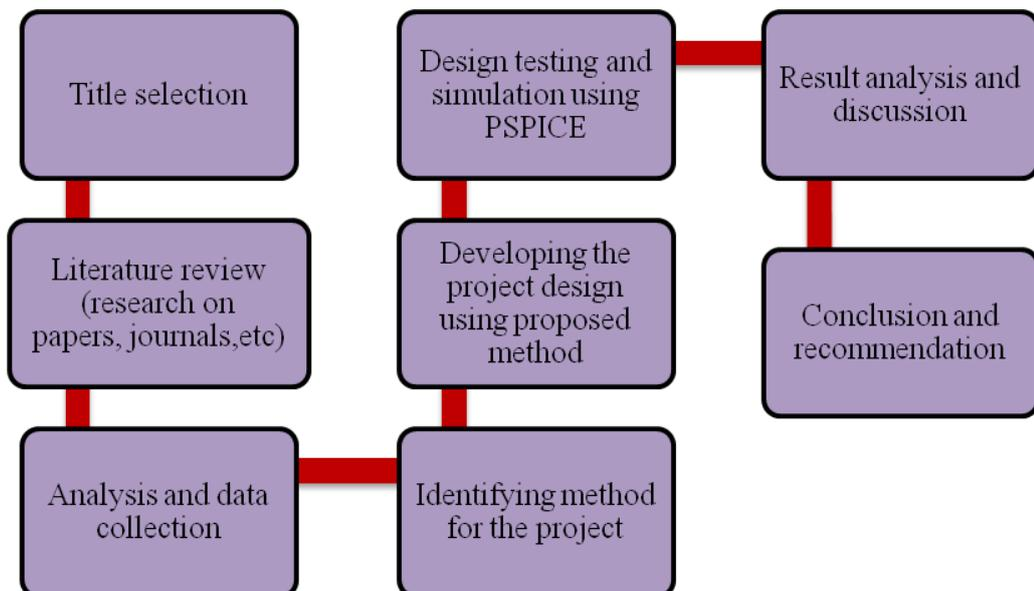

**Figure 9: Work flow for FYP**

### **3.3 Flow Chart and FYP timeline**

Flow chart is important as proper guideline for the completion of the project. In order to monitor the progress of this project, a Gantt chart consists of 2 semester duration has been constructed. It is to ensure the project is completed within the time frame. These two figures can be referring to Appendices section.

### **3.4 Tool required**

The PSPICE software is used as the main tool for the single phase to three phase converter design modeling. PSPICE is the suitable tool for converter modeling since there are many available applications can be applied in designing the project. Hence, there is also design toolbox such as MicroSim PSPICE for circuit simulation and also MicroSim PROBE to analyze the simulation results.

## CHAPTER 4

### RESULT AND DISCUSSION

#### 4.1 Design Specification

Throughout the completion of this project, there is few design specification that we expect to have once the project is completed. They are;

- Maximization in converter & drive efficiency
- Minimization in costs.
- Minimization of electrical and acoustic noise.
- Optimize the drive reliability

The choice of converter configuration is constrained by above considerations. There are many advantages that can be obtained for the future of variable speed drive technology if the above requirements are successfully implemented. For example, maximization in converter and drive efficiency can increase the life time of the drive itself. This can reduce the maintenance cost and increase profit.

#### 4.2 Design configuration

##### CONVENTIONAL DESIGN

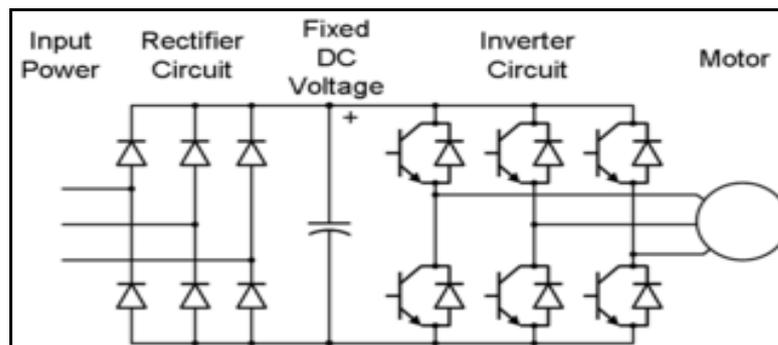

Figure 10: Conventional VSD Design

## PROPOSED DESIGN

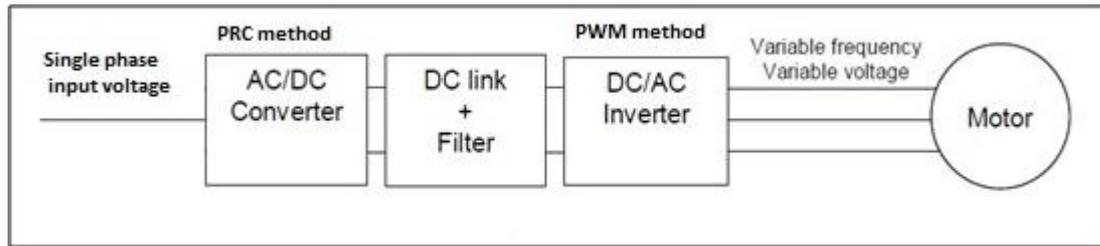

Figure 11: Proposed Project Design

The pictures above showing two different converter design configurations. The first picture is showing one of typical converter configuration that is available in the market nowadays. As we can see from the configuration, 3-phase power network is used as the converter power supply. A voltage input is put through the rectifier circuit to produce fixed dc voltage. The dc voltage will then be converted to a suitable 3 phase voltage suitable to power up 3-phase motor.

The second picture shows the simple draft configuration of author's design project. The different between this project with typical VSD is the power supply and method used for the converter configuration. In this project the power supply used is single phase power supply. The first step of the project is to design a converter using parallel resonant converter method to produce fixed stable dc voltage with high efficiency circuit. This voltage will then be fed into the six-step converter. Six-step converter will convert the voltage into suitable 3 phase voltage required by the load. This type of converter is actually still in research and not really implemented in the industry and VSD market.

### 4.3 Converter Design and simulation analysis

There are many steps involve in designing this converter. The first part of the design is to construct DC-DC converter by using parallel resonant converter (PRC) with rectifier. The main supply for the project application is single phase AC. In modelling the converter, input voltage source for converter circuit is assumed to be in DC voltage with assumption that some modification has been made to the circuit to produce DC voltage from the single phase AC supply as converter input voltage. The first part of the project will produce fixed DC voltage that will be fed to PWM inverter. PWM inverter will convert the fixed DC voltage into suitable 3 phase voltage output that will power up 3 phase equipment equipped with VSD applications. The detail analysis in the design procedure will be discussed further in this section.

#### 4.3.1 Parallel resonant tank component

Resonant tank components consist of capacitor and inductor. These two components are very important as it will be using as the reference in designing the converter. The value can be determined from formula below with capacitor and resonant frequency is assumed to a certain value.

$$F = \frac{1}{2\pi\sqrt{LC}} \dots\dots\dots (1)$$

In this design, the resonant frequency is assumed to be **Fr = 45 KHz** and capacitor value is set to be **C = 16.5nF**. By substituting above value in (1) will results in **L = 0.743mH**. These values will be used for the resonant tank component. For characteristic impedance (2) and quality factor (3) can be calculated using formula below where **R<sub>L</sub>** is the load resistance of the circuit. As component stresses are directly a function of **Q**, so the value of **Q** should be chosen as low as possible. In the design the value for both **Z<sub>c</sub>** and **Q** are calculated result in **Z<sub>c</sub> = 212.2 & Q = 0.7**.

$$Z_c = \sqrt{\frac{L}{C}} \dots\dots\dots (2)$$

$$Q = \frac{Z_c}{R_L} \dots\dots\dots (3)$$

#### 4.3.1.1 Circuit configuration

Based on calculated value given above circuit design is constructed using PSPICE software. The first figure is designing the circuit with simple pulse voltage. The second figure is developing the simple design with implementation of switching devices. The purpose of this procedure is to verify whether the new implemented design configuration and the switching devices chosen are compatible with the rating requirement based on the output given from simulation analysis.

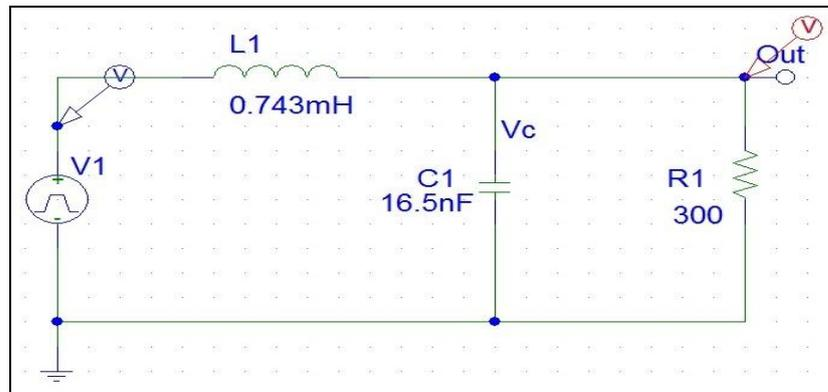

Figure 12: Simple circuit design

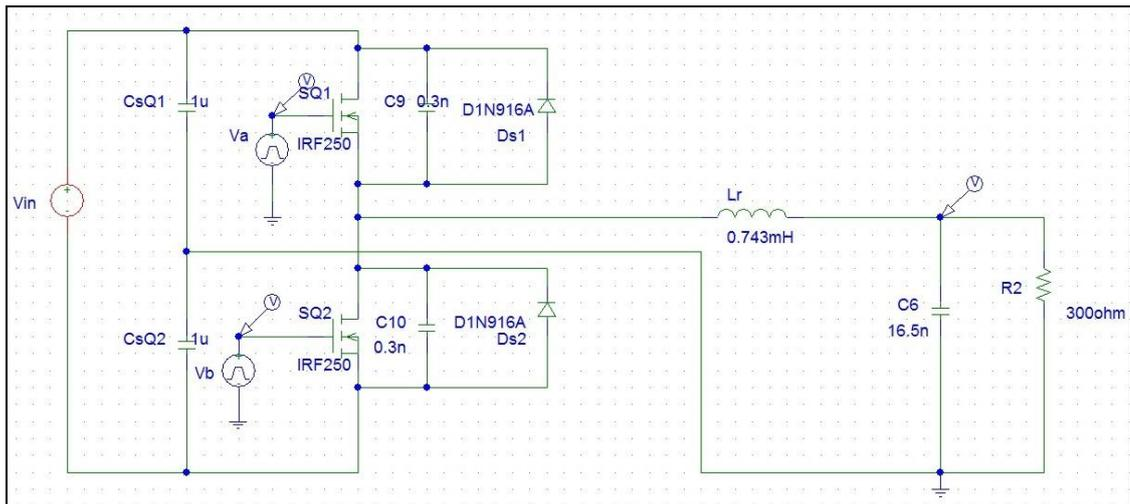

Figure 13: Circuit design with switching device implementation

In above figure C6 and Lr are the resonant tank component. The capacitor CsQ1 and CsQ2 serve only to split the DC voltage Vin. Power MOSFET is chosen as the switching device. Diode connected parallel with the MOSFET is to block and bypass the current through the body diode with substantially higher conduction losses.

### 4.3.1.2 Simulation analysis

This section will discuss the output simulation from figure 12 and figure 13. From the graph the author can conclude that the output is almost the same for both circuit configurations. Both circuits are run at resonant frequency. The peak and rms value for both inductor and capacitor voltage are tabulated in the table 2. To calculate rms value equation below is used:

$$V_{rms} = \frac{V_p}{\sqrt{2}} \dots\dots\dots (4)$$

$$I_{rms} = \frac{I_p}{\sqrt{2}} \dots\dots\dots (5)$$

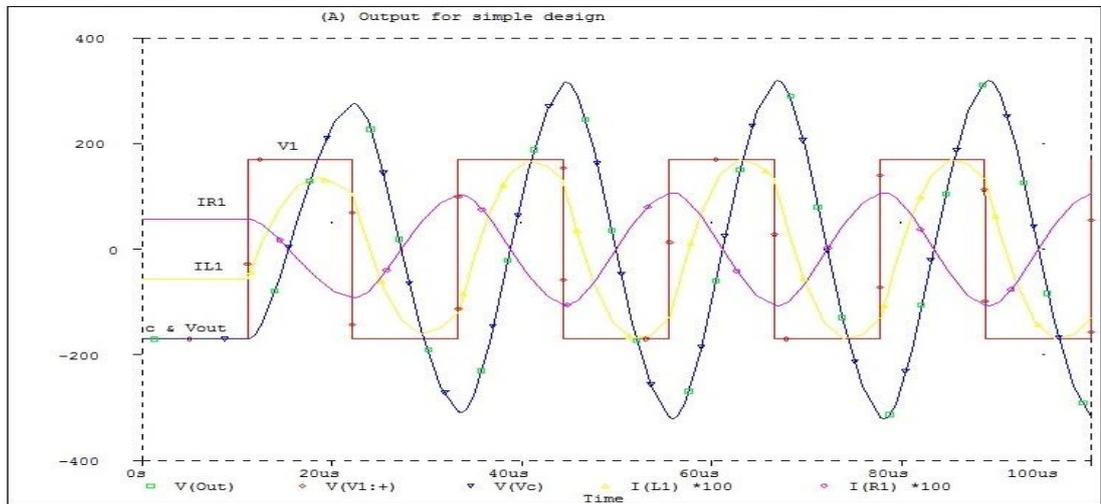

Figure 14: Output for circuit in figure 12

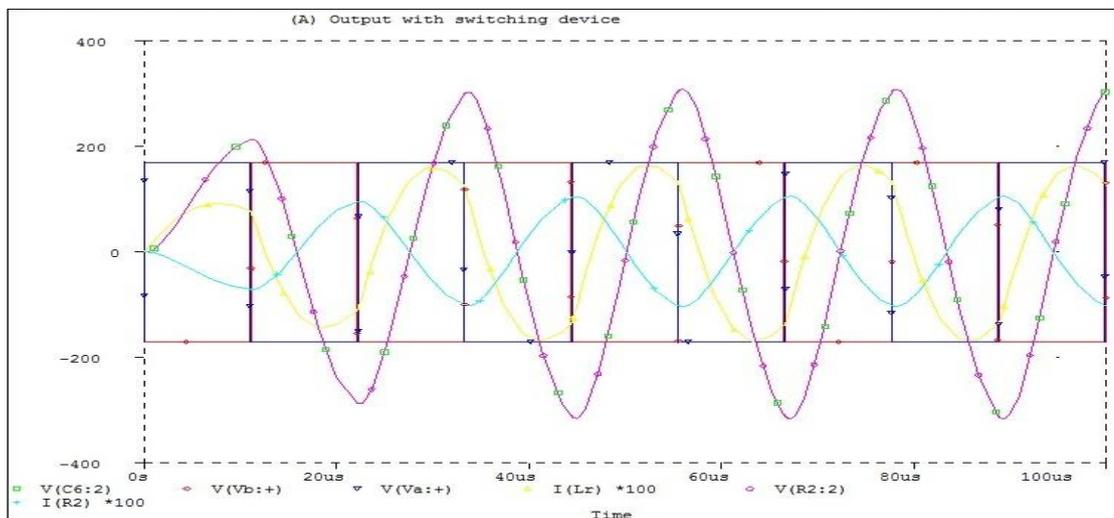

Figure 15: Output for circuit in figure 13

<b>Circuit Design</b>	<b>Without switching device</b>	<b>With switching device</b>
V <sub>c</sub> , p	318V	307V
V <sub>c</sub> , p-p	638V	625V
V <sub>c</sub> , rms	225V	217V
I <sub>Lr</sub> , p	1.68A	1.67A
I <sub>Lr</sub> , p-p	3.36A	3.37A
I <sub>Lr</sub> , rms	1.19A	1.18A

Table 2: Voltage across capacitor and current through resonant inductor

Based on the value given above there are only slight different between the two circuit configurations and the value is in still acceptable range. Based on this analysis the author can continue with the development of the converter circuit. For ideal performance, switching frequency must be greater than resonant frequency  $> 45$  KHz.

#### **4.3.2 Switching circuit analysis**

The author is using 45 KHz as a resonant frequency. The switching for MOSFET should be above resonant value for proper modeling and better performance. For the time being the author is using frequency of 50 KHz for the circuit simulation modeling.. Analysis on the result simulation will be discussed further in this section.

#### **Design Condition for $F_s = 50$ KHz**

Design Specification	V <sub>a</sub> (Switching 1)	V <sub>b</sub> (Switching 2)
V1	170V	-170V
V2	-170V	170V
Time Delay	0 us	10us
Time Rise	10ns	10ns
Time Fall	10ns	10ns
Pulse Width	9.88us	9.88us
Period	20us	20us

Table 3: Design specification on MOSFET

To determine the required pulse width (PW) for the MOSFET switching there is formula involves:

$$PW = (\text{Period}/2) - \text{Time Delay} - \text{Time Rise} - \text{Time Fall} \dots\dots\dots (6)$$

The author is using 50 KHz above resonant. Based on the formula

$$f = 1/T \dots\dots\dots (7)$$

the period can be determined which equal to 20us. From there, use the value in the formula to determine PW.

$$PW = (20\mu\text{s}/2) - 10\text{ns} - 10\text{ns} - 0.1\mu\text{s} = 9.88\mu\text{s}$$

Simulation and analysis has been done using PSPICE in order to produce the desired result for circuit in figure 13. There are two parts of switching that the author needs to analyze which consists of lossless switching and current switching.

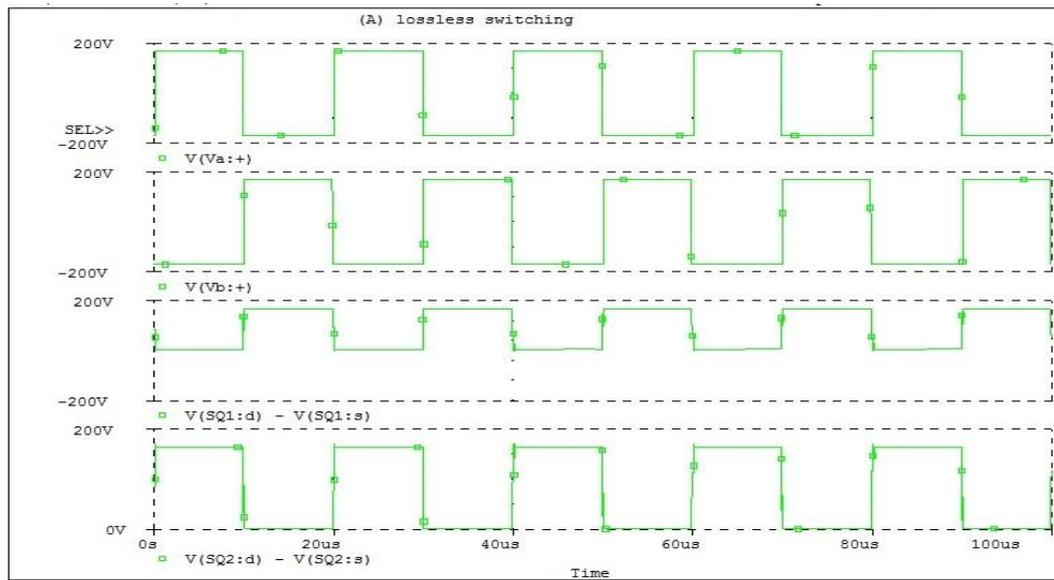

Figure 16: Lossless switching

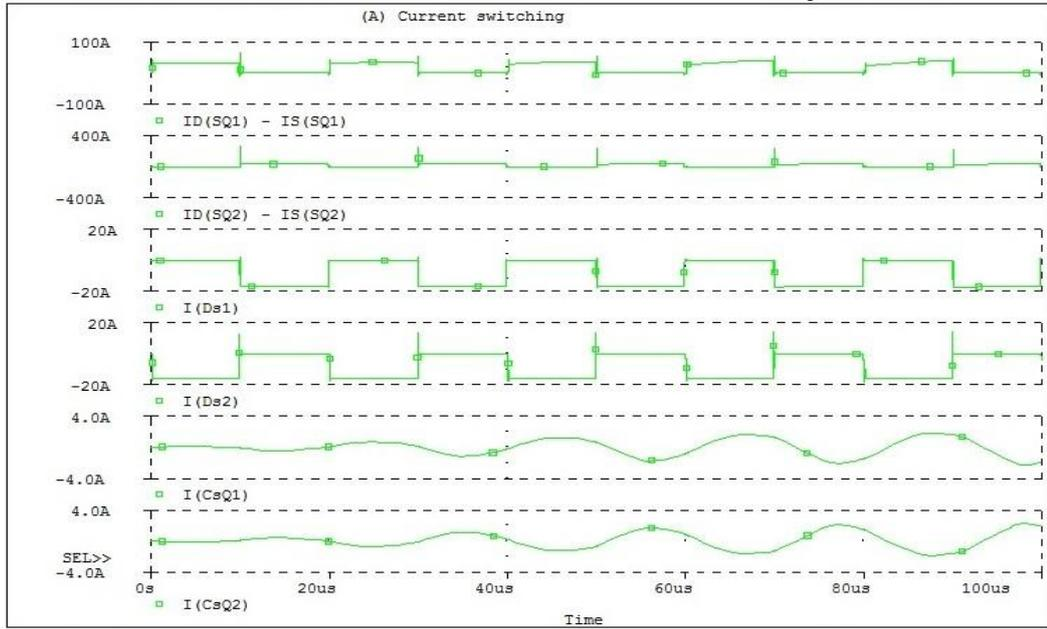

Figure 17: Current switching

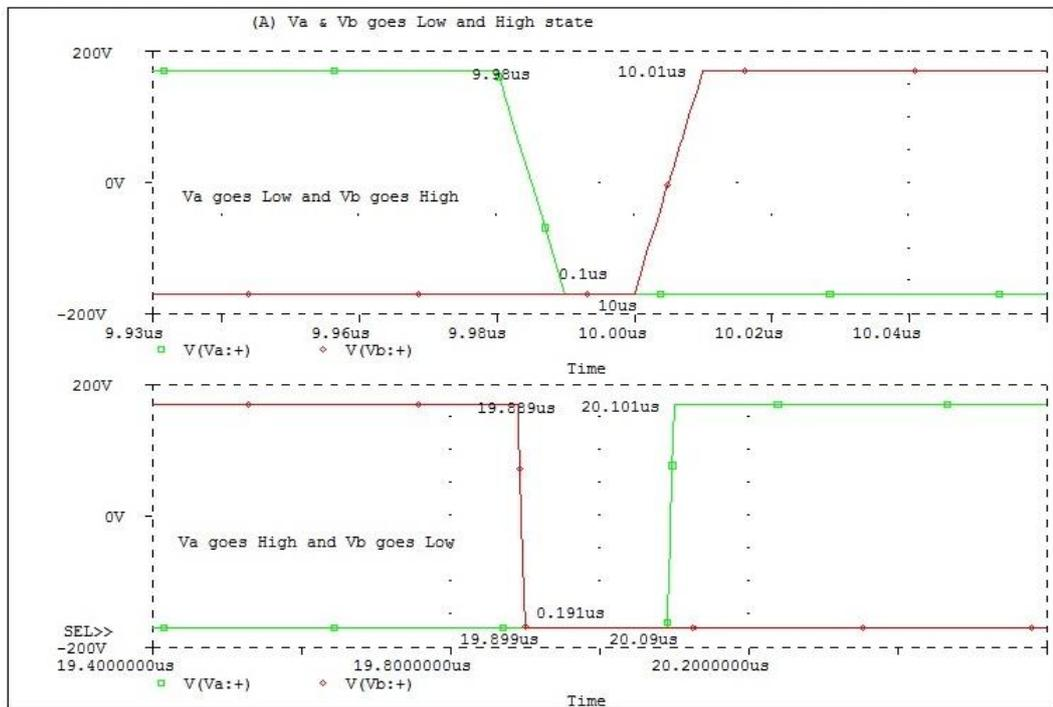

Figure 17: State transition between Va & Vb

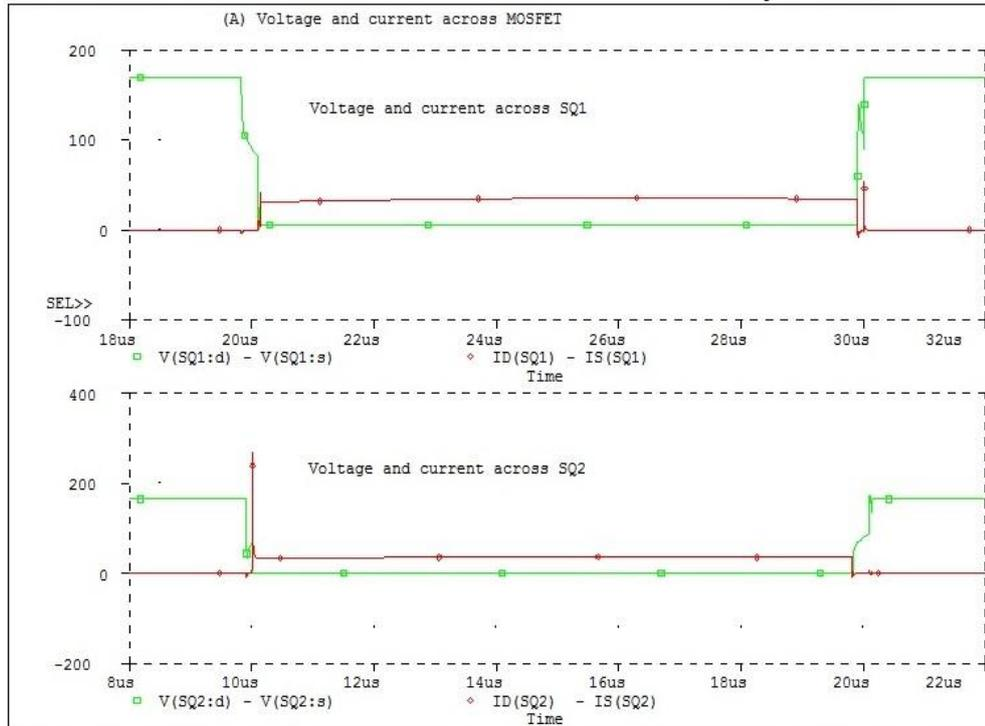

Figure 18: Turn on Lossless switching

All the figures above show the general waveform of the parameter required for the design. For the first part the author need to analyze the current switching of the design. Current switching analysis is very important and should be taken into consideration when designing circuit involving switching because they can affect the signal integrity and overall test performance. For the second part the author need to analyze the lossless switching part of the circuit. Further analysis on the waveform will be discussed below.

From above waveform, what the author can conclude was, when switching input voltage  $V_a$  &  $V_b$  go to high and low state simultaneously there are also changes occurs to the current. This is call transient current spikes. Spikes can be defined as fast or short electrical transient in electrical circuit. Current spikes usually occur when the transistor of the semiconductor goes high and low states simultaneously. Excessive current flow in the device may cause the material breakdown of the device. This occurs when voltage spike exceeds a material's breakdown voltage. When the MOSFET switch ON and OFF the parasitic capacitance stores and dissipates energy at each switch transition. This can cause switching losses. By focusing on the timing

of the switches there are like to dead time intervals in each switching cycle as shown in figure 17. During the time intervals, the charge stored on parasitic capacitances of input switches is partially re-circulated resulting in some switching loss reduction. This is called soft-switching operation. This is where proper switching for the MOSFET is very important. The smaller the losses can improve the circuit performance.

$$P_{switching} = \frac{V_s(OFF) \times F_s}{2} \times [t_{on} + t_{off}] \times I_{on}$$

$$P_{conduction} = I_{on}^2 R_{ds,on}$$

$$P_{total} = P_{switching} + P_{conduction}$$

Figure 19: Switching losses formula

Based on above formula switching losses of MOSFET can be determined. The result is tabulated in table 4. The design meet the requirement for parallel resonant converter method as the switching losses is very small.

Losses	MOSFET	
	SQ1	SQ2
Pswitching	9.02W	8.06W
Pconduction	104.125W	104.125W
Ptotal	113.145W	112.18

Table 4: Losses for circuit condition of 50 KHz

### 4.3.3 Parallel loaded resonant converter

For this section the author need to extend the circuit in figure 13 by adding transformer with rectifier to the design and analyze the output waveform. Detail study and analysis should be done by the author in order to meet the objectives. Figure below shows the extended version of circuit in figure 13.

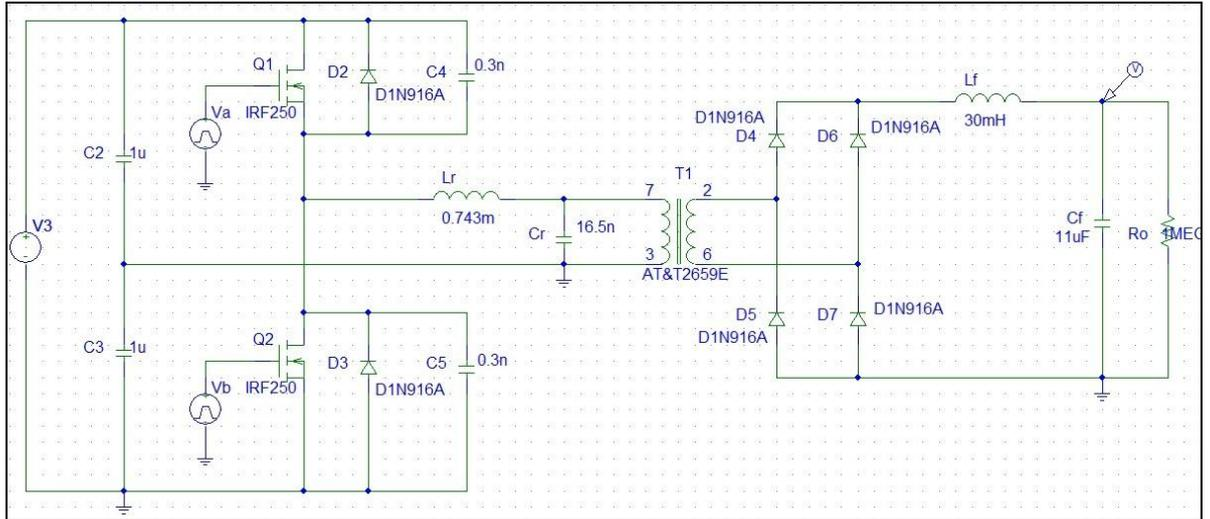

Figure 20: Extended version of parallel resonant converter circuit

In above design, the load is connected directly across resonant capacitor  $C_r$  via full wave rectification circuit with filter component. The design is using half bridge PRC. The power MOSFET Q1, Q2 and its anti parallel diode D2, D3 act together as a bidirectional switch S1 and S2. The positive portion of the current will flows through MOSFET Q1 and Q2 while the negative portion flows through the anti parallel diode. The switching frequency of the inverter will be higher than the corner frequency of output filter made the output current can be considered constant during the switching period. High frequency transformer is placed between the inverter and rectifier to provide isolation and voltage step up and step down. The analysis of the circuit design is carried out under below assumptions:

- All components are ideal
- Output current is constant during switching period
- Turn ratio of transformer is 1:1

Figure 21 shows the equivalent circuit of the converter.  $V_e$  is the effective input voltage of the resonant converter equivalent with  $\pm \frac{V_{in}}{2}$  while  $I_e$  is effective load current equivalent with  $\pm I_o$ .

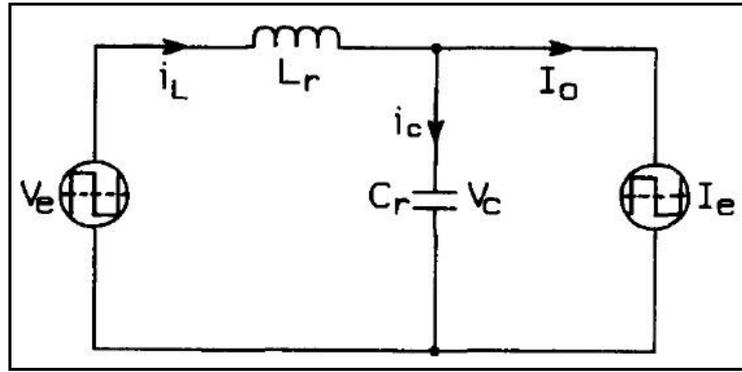

Figure 21: Equivalent circuit of PRC

There are four topological mode occurs in PRC circuit which describes in table below.

MODE	$V_e$	$I_e$
Mode A	$+\frac{V_{in}}{2}$	$-I_o$
Mode B	$+\frac{V_{in}}{2}$	$+I_o$
Mode C	$-\frac{V_{in}}{2}$	$+I_o$
Mode D	$-\frac{V_{in}}{2}$	$-I_o$

Table 5: Four topological mode in PRC

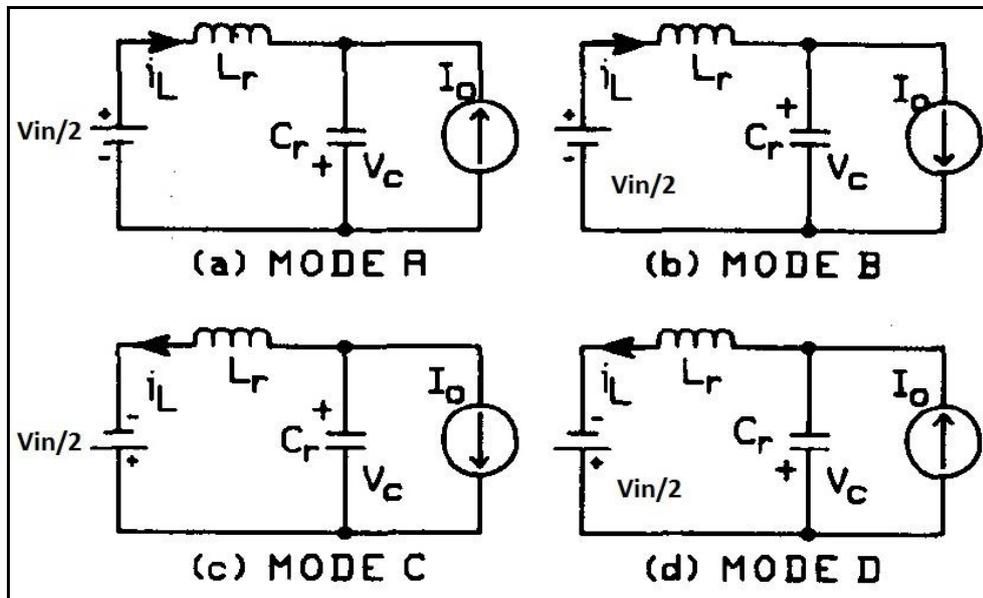

Figure 22: Four topological mode in PRC

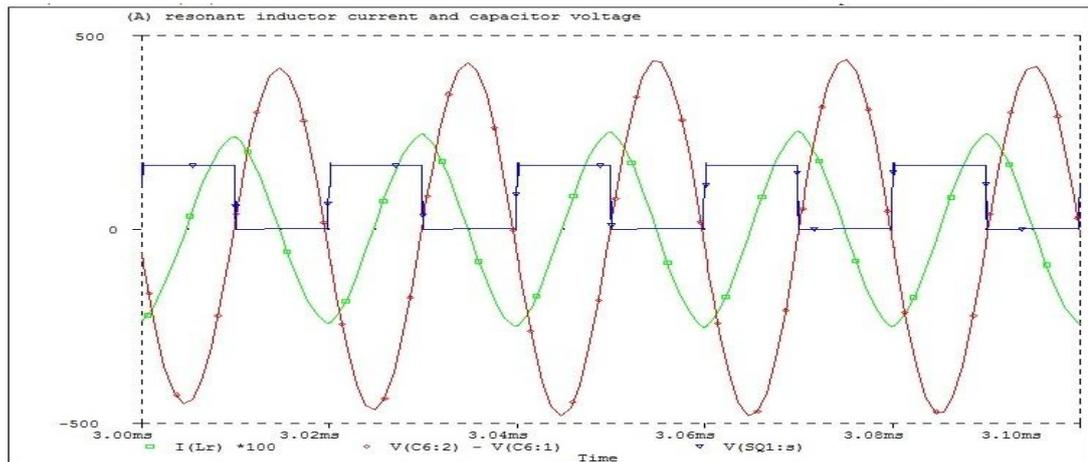

Figure 23: Waveform for PRC above resonant

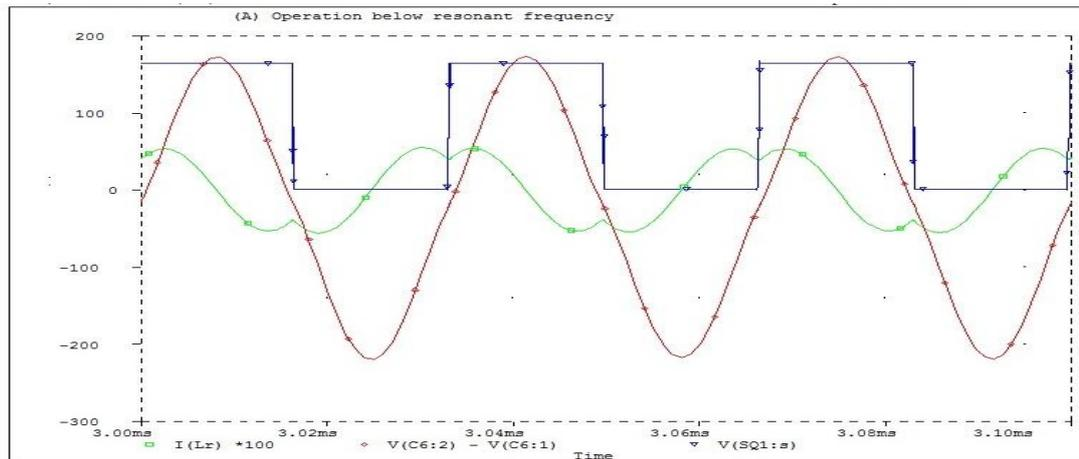

Figure 24: Waveform for PRC below resonant

Both figure 23 and 24 are evaluated based on continuous conduction mode (CCM) operation. CCM occurs when operating frequency above resonant frequency and greater than  $\frac{1}{2} F_r$  for below resonant operation. When operate above resonant frequency capacitor voltage,  $V_c$  and inductor current,  $I_{Lr}$  will be non-positive value. For below resonant operation in figure 24, the switch turns ON at a finite  $I_{Lr}$  and current commutates from the diode connected in anti parallel with the other switch. This result in turn on losses in the switches and the diodes must have good reverse-recovery characteristic. There are no turns off losses since current commutates naturally when  $I_{Lr}$  reverse in direction. For above resonant operation in figure 23, turn-on losses in the switches are eliminated since switches turn on naturally  $I_{Lr}$  initially flowing through the diode, reverses.

The main objective of this activity is to produce constant output with variable input. It is possible to maintain constant amplitude of output voltage in the face of variation in the source voltage and the load resistance. By changing the frequency the output voltage can be regulated against source voltage variation. DC output voltage can be regulated by varying the frequency of the MOSFET.  $V_{in}$  varies from 220V – 340V. Based on this given voltage switching frequency is determined in order to produce fixed 100V dc at the output voltage. Table 6 shows the result for corresponding voltage and switching frequency. The output waveform of 100V is shown in figure 26.

$V_{in}$ (V)	Load (ohm)	Switching Frequency (K Hz)
220V	1M	60
250V	1M	105
280V	1M	55
310V	1M	75
340V	1M	65

Table 6: Input Voltage and corresponding switching frequency

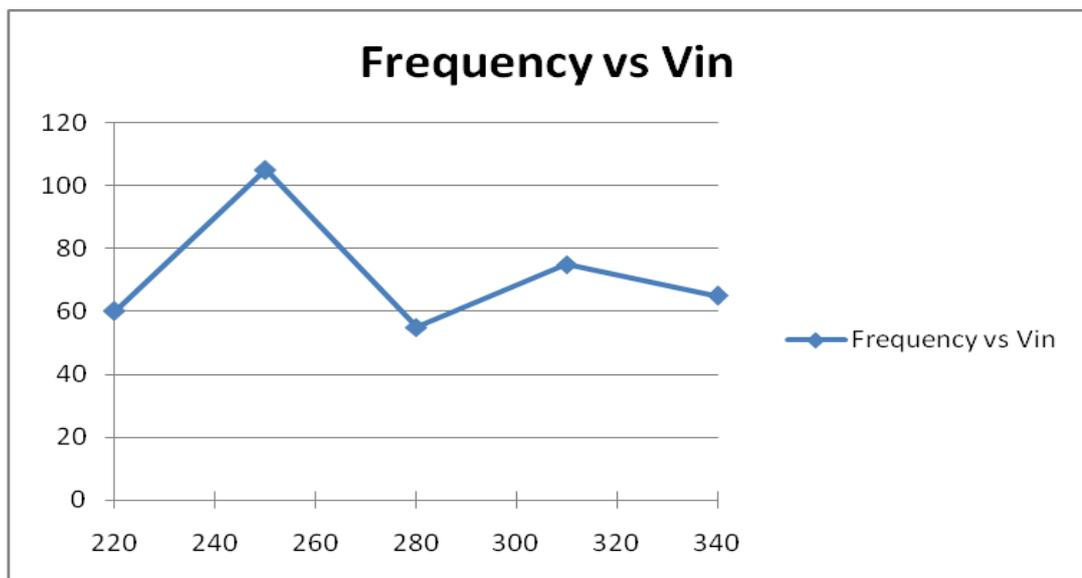

Figure 25: Graph of frequency versus output voltage

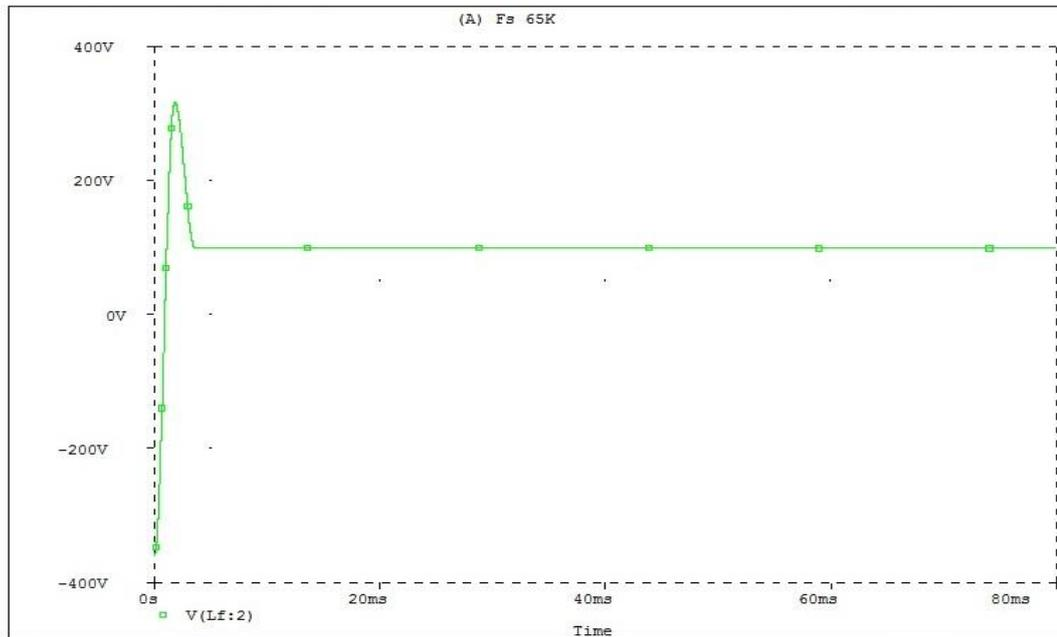

Figure 26: The output waveform of 120V

#### 4.3.4 Output filter component

The converter is designed using following specifications:

- Input voltage =  $V_{in} = 230V$ ,  $f_{in} = 50\text{ Hz}$
- Output voltage =  $V_o = 120V$
- Output power  $P_o = 2.5\text{ KW}$
- Minimum switching frequency  $f_s = 50\text{ kHz}$
- Peak to peak current ripple = 25 % of  $I_o$
- Peak to peak voltage ripple = 10 % of  $V_o$

The output filter of the component,  $L_f$  must suppress the switching frequency components of the rectified resonant capacitor voltage  $V_r$ , which under typical operating condition is sinusoidal. The DC component of  $V_r$  must equal the output voltage  $V_o$ . Under the worst case assumption that the peak of  $V_r$  remain constant over the 100 Hz cycle, the magnitude of its harmonic components are given as,

$$V_r(n) = \frac{2V_o}{4n^2 - 1} \dots\dots\dots(8)$$

Where  $n$  is multiple of  $2f_s$  and  $f_s$  is the switching frequency. Assuming that the

dominant component of the ripple current in  $L_f$  is at  $n=1$ . This ripple current is

$$I_o (\sim p-p) = \frac{V_o}{3\pi f_o L_f} \dots\dots\dots(9)$$

Where  $f \sim f_o$ . Hence  $I_o (\sim p-p) = 25\% * 0.03A = 8.49mA$ .

From equation (9)  $L_f$  can be computed.

$$L_f = (120V) / (3\pi \times 50 \text{ KHz} \times 8.49mA) = 30mH$$

The magnitudes of the harmonic components of the rectified output current are given by

$$I_{rn} = \frac{2 I_o}{4 n^2 - 1} \dots\dots\dots (10)$$

The dominant component of this current is at  $n = 1$  at  $2 f$  in. This is given by

$$I_{r1} = \frac{2 I_o}{3} \dots\dots\dots (11)$$

Hence the output voltage ripple can be determined using below equation:

$$V_p (\sim p-p) = \frac{2 I_o}{3 \pi f_{in} C_f} \dots\dots\dots (12)$$

Where  $V_p (\sim p-p) = 10\% \times 120 = 12V$ . The output-filter capacitance is required to limit the double-line-frequency component of the rectifier output voltage to the ripple specification and minimized ripple voltage. By substituting the value into equation (12) the value of  $C_f$  can be computed.

$$C_f = \frac{2 \times 0.03}{3 \times \pi \times 50 \times 12} = 11\mu F$$

The use of  $L_f$  reduces the charging current of  $C_f$ . This in turn will reduce the line current of the converter, the stresses on the resonant-tank components and also improving the efficiency of convertor.

### 4.3.5 The Six-step Inverter

The last part of the project is to produce a three-phase ac from a dc input. Figure 27 shows the circuit configuration for this operation. A major application of this circuit is speed control of induction motors where the output frequency is varied. The switches are closed and open according to sequence given in figure 28. Switching action takes place every  $T/6$  time interval. S1 and S4 close and open opposite of each other and same goes with other switch pair (S2, S5) and (S3, S6). This switch pair must not coordinate so that they are not closed at the same time that will result in short circuit across the source. The three phase load connected to output voltage is connected in ungrounded-neutral wye. The output frequency can be change by changing the switching frequency. The magnitude of output voltage depends on the value of dc supply voltage. To control the output voltage of six-step inverter the dc input must be adjusted.

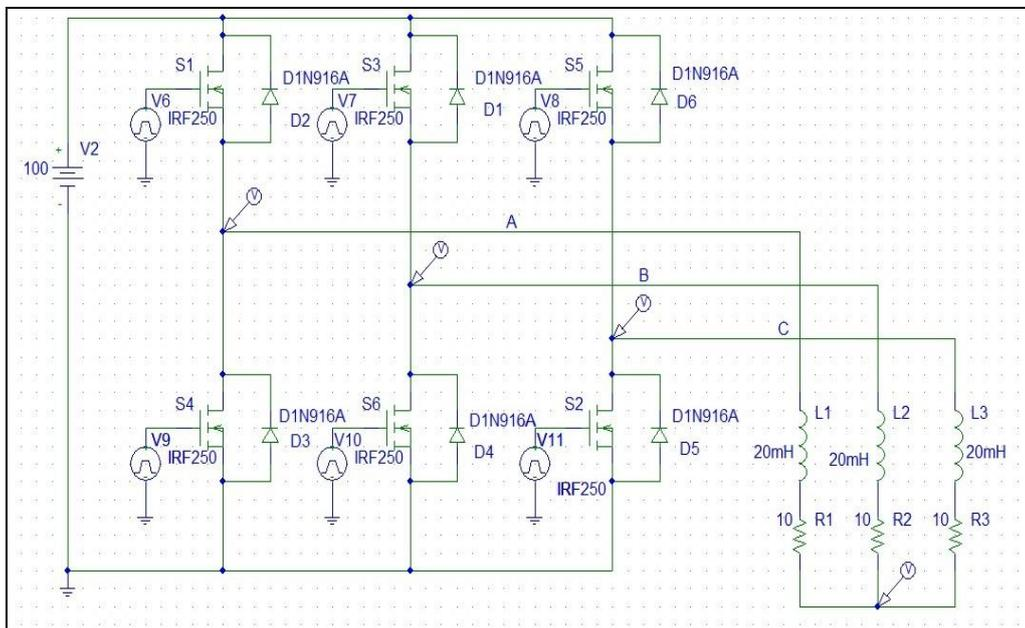

Figure 27: Circuit diagram

Analysis on the output waveform for above circuit configuration is shown below. Table 7 shows the switching parameters for all six MOSFET.

#### 4.3.5.1 Switching parameters

Switches	S1	S2	S3	S4	S5	S6
V1	-100V	-100V	-100V	-100V	-100V	-100V
V2	100V	100V	100V	100V	100V	100V
TD	0s	3.33ms	6.67ms	10ms	13.33ms	16.67ms
TF	10us	10us	10us	10us	10us	10us
TR	10us	10us	10us	10us	10us	10us
PW	10ms	10ms	10ms	10ms	10ms	10ms
PER	20ms	20ms	20ms	20ms	20ms	20ms

Table 7: The switching parameter for all six MOSFET.

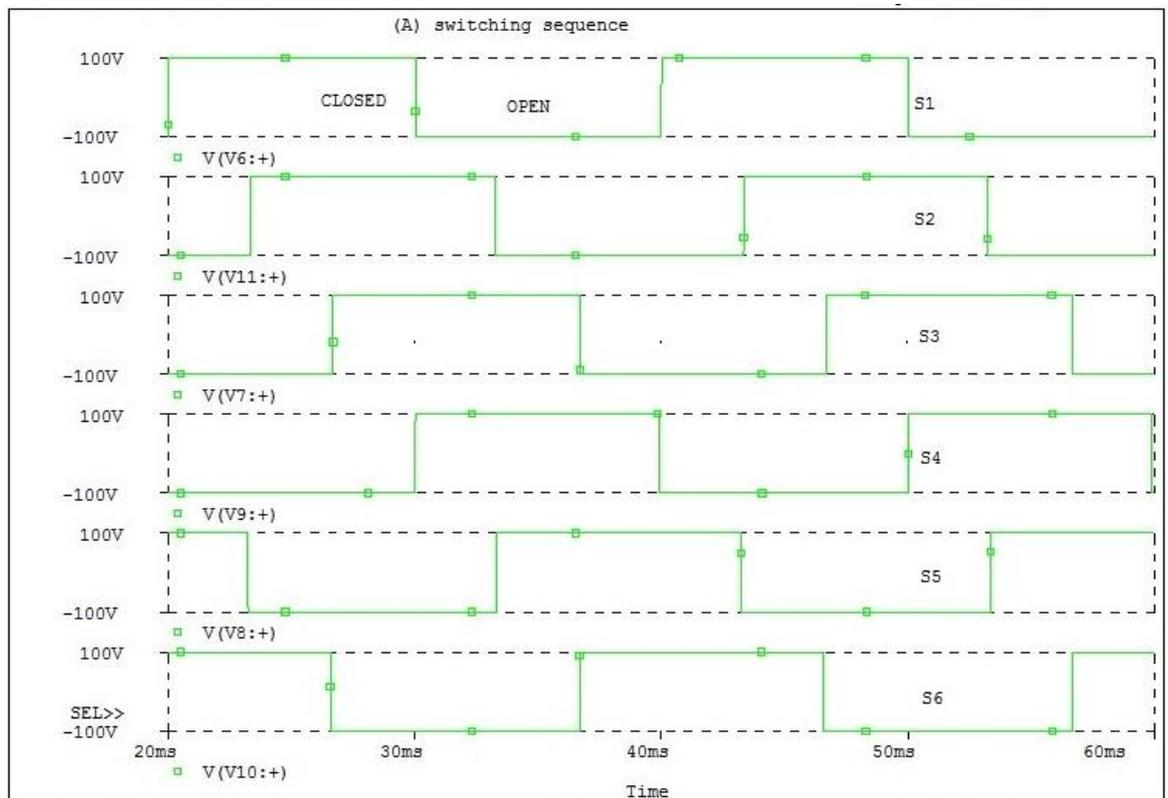

Figure 28: Switching sequence for six-step output

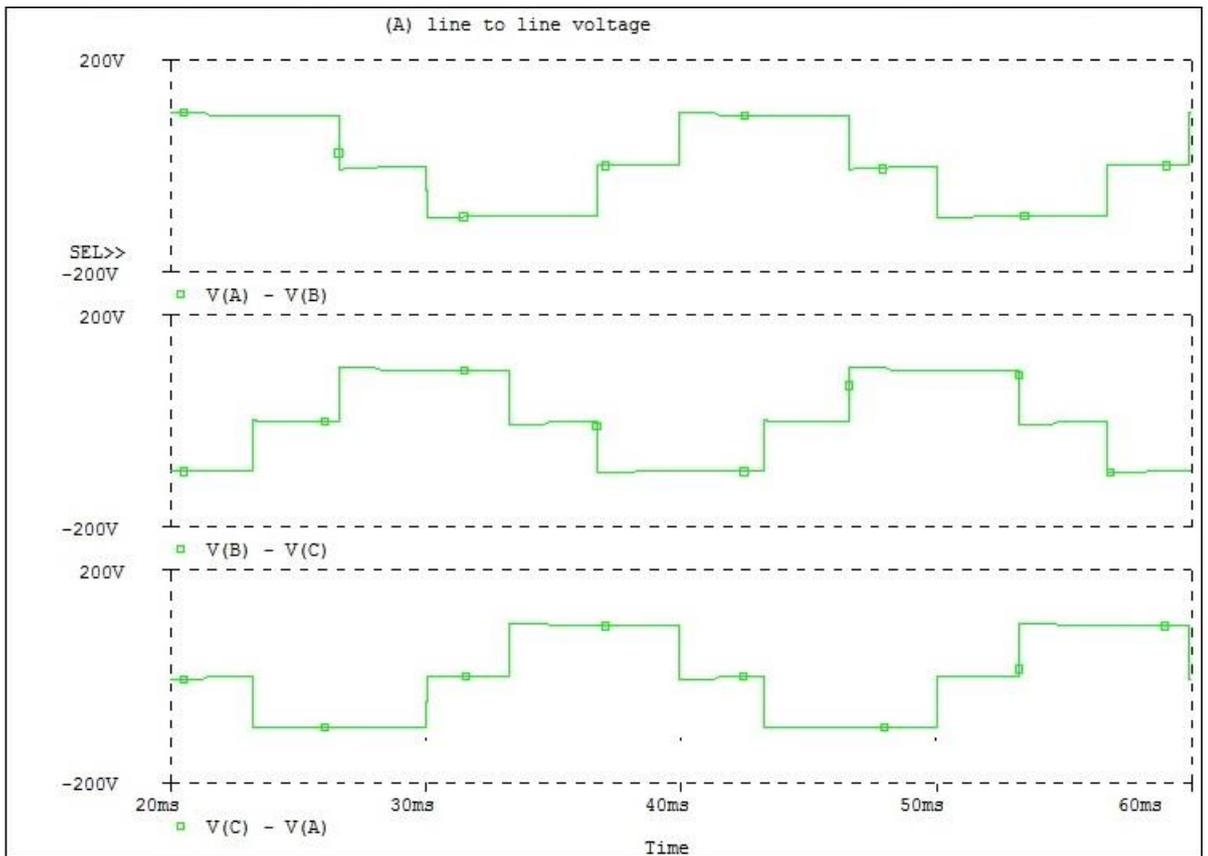

Figure 29: Line to line output voltages

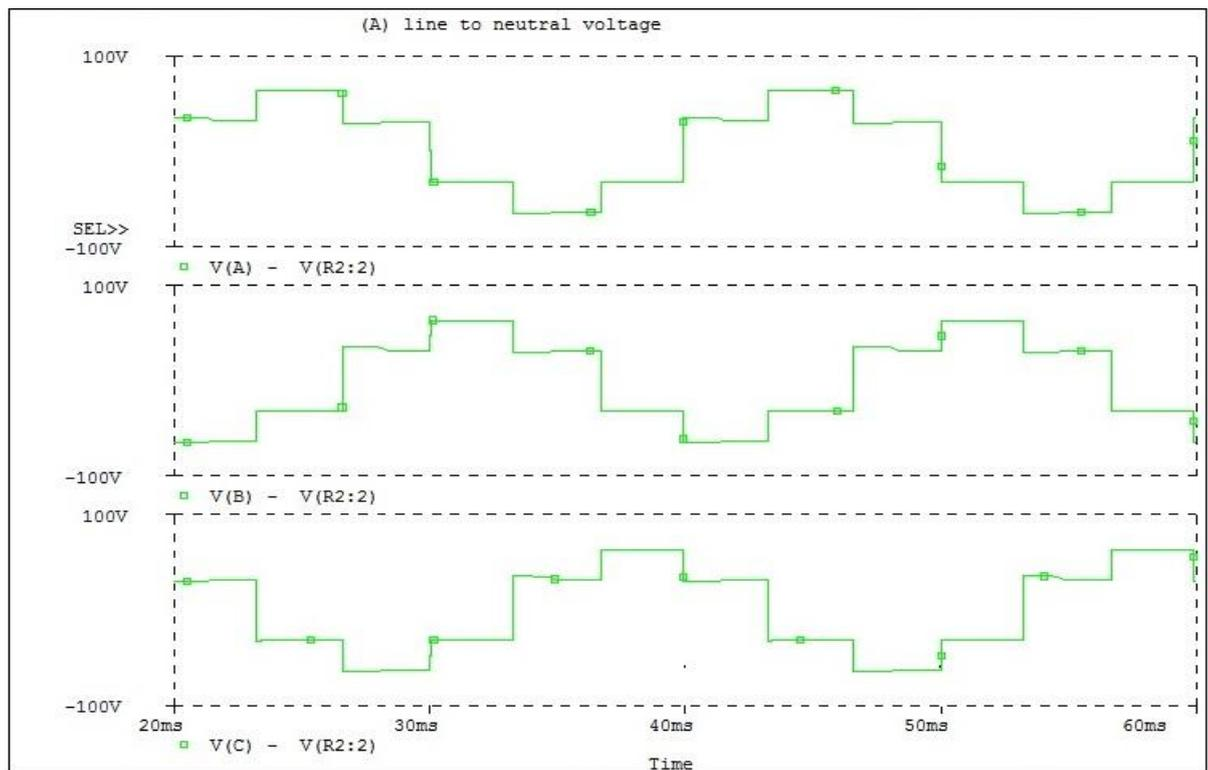

Figure 30: Line to neutral voltages for an ungrounded Y-connected circuit

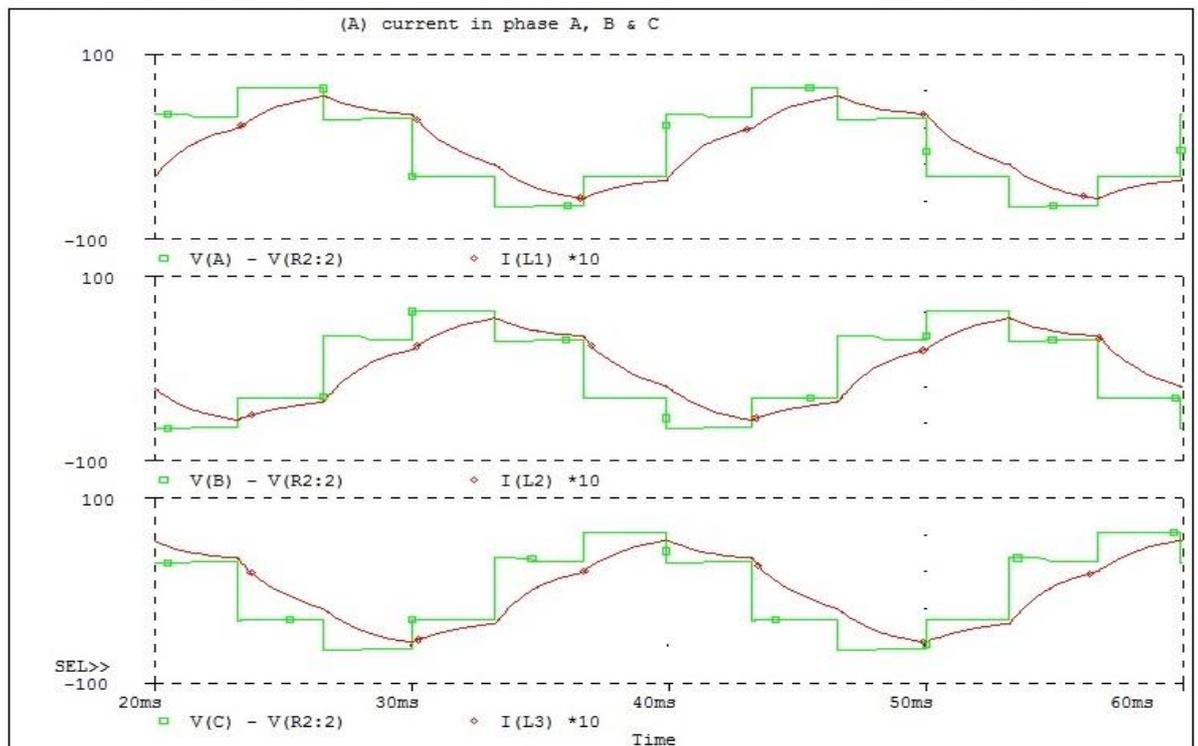

Figure 31: Current in Phase A, B & C

For this method, the Fourier series for the output voltage has a fundamental frequency equal to the switching frequency. Harmonic frequencies are on the order of  $6k \pm 1$  for  $k = 1, 2, \dots$  with  $(n = 5, 7, 11, 13 \dots)$ . The third harmonic and multiples of the third do not exist and even harmonics do not exist. For an input of  $V_{dc}$ , the output for an ungrounded wye-connection load has the following Fourier coefficients:

$$V_{n,L-L} = \left| \frac{4V_{dc}}{n\pi} \cos\left(n\frac{\pi}{6}\right) \right| \dots \dots \dots (13)$$

$$V_{n,L-N} = \left| \frac{2V_{dc}}{3n\pi} \left[ 2 + \cos\left(n\frac{\pi}{3}\right) - \cos\left(n\frac{2\pi}{3}\right) \right] \right| \dots \dots \dots (14)$$

With  $n = 1, 5, 7, 11, 13 \dots \dots \dots$

The THD of both line-to-line and line-to-neutral voltages can be shown to be 48.3% from the equation (15) given below.

$$THD = \frac{\sqrt{\sum_{n=2}^{\infty} (V_{n,rms})^2}}{V_{1,rms}} = \frac{\sqrt{V_{rms}^2 - V_{1,rms}^2}}{V_{1,rms}} \dots\dots\dots(15)$$

The THD of the current is load dependent and is smaller for an R-L load. An example of the line to neutral voltage and line current for R-L wye-connected load is shown on figure 31. The output frequency can be controlled by changing the switching frequency. The magnitude of the output voltage depends on the value of the dc supply voltage. To control the output voltage of six step inverter the dc input voltage must be adjusted. The amplitude of load current at each frequency is determined in given equation;

$$I_n = \frac{V_{n, L-N}}{Z_n} = \frac{V_{n,L-N}}{\sqrt{R^2 + (nw_oL)^2}} \dots\dots\dots(16)$$

Where  $V_{n,L-N}$  is determined from equation (14). The THD of load current is computed from equation (16) as

n	$V_{n,L-N}$	$Z_n (\Omega)$	$I_n (A)$	$I_{n,rms} (A)$
1	42.45	11.81	3.59	2.54
5	8.54	32.96	0.26	0.18
7	6.14	45.10	0.14	0.10
11	3.97	69.83	0.06	0.04
13	3.398	82.29	0.04	0.03

Table 8: Fourier component for six-step inverter

Based on table above the THD of load current can be computed using equation (17).

$$THD_I = \frac{\sqrt{\sum_{n=2}^{\infty} I_{n,rms}^2}}{I_{1,rms}} \dots\dots\dots(17)$$

By substituting the value in the equation

$$THD_1 = \frac{\sqrt{(0.18)^2 + (0.10)^2 + (0.04)^2 + (0.03)^2}}{2.54}$$

$$THD_1 = 0.083 = 8.3\%$$

#### 4.3.6 Circuit configuration for proposed design

Section 4.3.3 and 4.3.5 have been discussing about the steps and analysis done on the proposed method. Based on that analysis complete full configuration has been design by combining both two methods in one circuit. Figure below shows the complete circuit configuration of the design.

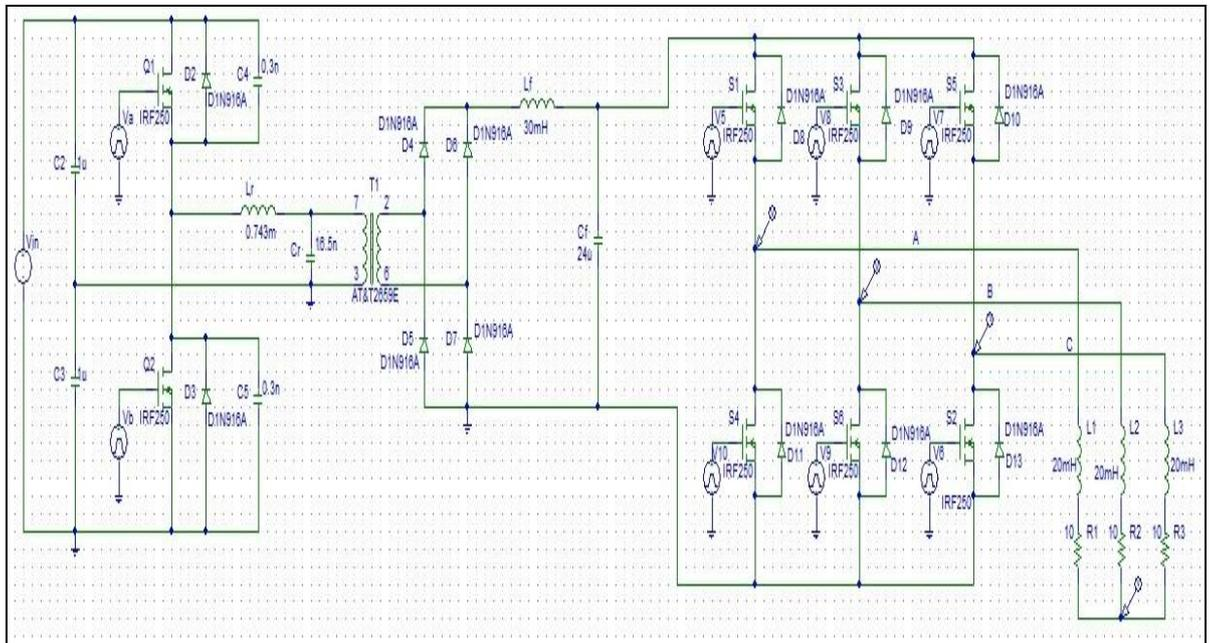

Figure 32: Complete circuit configuration

## CHAPTER 5

### CONCLUSION

In conclusion, this project is about designing the single phase to three phase converter and performed the converter modeling and simulation using proposed tools or software which is PSPICE software. The author needs to have thorough understanding of the basic concept related to the project and doing some research is the best method to achieve this. The proposed methodology used in this project can be applied in order to achieve the objectives and completing the project within the given time frame.

The first part of the design process is to determine the resonant inductor and capacitor value based on resonant frequency. Then the output is analyzed when the frequency is varies above resonant. Based on the simulation analysis high switching frequency will results in decreasing value of both output voltage and current. The current value is in between -2A to 2A range. The output current  $I_{RL}$  becomes almost zero for switching frequency above 150 KHz. For ideal performance, switching frequency must be greater than resonant frequency which is assumed to be 45 KHz.

The second part is to design the converter that produce 3 phase ac output from a dc input. Six-step inverter method is chosen as the proposed methodology in designing the dc-ac converter. Simulation analysis has been done based on output waveform of the circuit. It has been proved that parallel resonant converter method can be use to keep the switching losses to a minimum value for better circuit performance. It is possible to maintain a constant amplitude of output voltage in the face of variation in the source voltage and the load resistance. By changing the frequency the output voltage can be regulated against source voltage variation.

This project is only focus on the methodology used to design single phase to three phase converter without the implementation of control strategy. In future, some improvement could be made to the design such as installing controller using microprocessor device for better converter performance and efficiency.

## REFERENCES

- [1] Chen, C.-c., Divan, D.M., and Novotny, D.W., “A single Phase to Three Phase converter for motor drive applications,” Conference Record of the 1992 IEEE Industry Applications Society Annual Meeting, vol. 1, no. 1, pp. 639–646, Oct. 1992.
- [2] Enjeti, P.N., Rahman, A. and Jakkli, R., “Economic single-phase to three-phase converter topologies for fixed and variable frequency output,” Power Electronics, IEEE Transactions on, vol. 8, pp. 329–335, Jul. 1993.
- [3] H. N. Hickok, “Adjustable speed a tool for saving energy losses in pumps, fan, blowers and compressors,” *IEEE Trans. Ind. Appl.*, vol. IA-21, no. 1, pp. 124–136, Jan. 1985.
- [4] European Commission, "Study on Technical/Economic and Cost/Benefit Analyses of Energy Efficient Improvements in Industrial Three-Phase Induction Motors", DGXII Energy, October 1999.
- [5] Available: “Energy efficiency makes differences”, ABB.
- [6] Thida Win, Nang Sabai and Hnin Nandar Maung, “Analysis of Variable Frequency Three Phase Induction Motor Drive”, World Academy of Science, Engineering and Technology 42, 2008.
- [7] Toshihiro Sawa and Tsuneo Kume, “Motor Drive Technology: History and Visions for the Future”, 35th Annual IEEE Power Electronics Specialists Conference, 2004.
- [8] Rasmussen, C.B., Ritchie, E. & Arkkio, A., “Variable speed induction motor drive for household refrigerator compressor”, Proceedings of the IEEE International Symposium on ISIE '97., Vol. 2, pp. 655-659, 1997.
- [9] H. N. Hickok, “Adjustable speed a tool for saving energy losses in pumps, fan, blowers and compressors,” *IEEE Trans. Ind. Appl.*, vol. IA-21, no. 1, pp. 124–136, Jan. 1985.
- [10] Dong Choon Lee. and Young Sin Kim., “Control of Single-Phase-to-Three-Phase AC/DC/AC PWM Converters for Induction Motor Drives”, Industrial Electronics, IEEE Transactions on, Vol. 54, pp. 797-804, April . 2007.

- [11] Ohnishi, T., "PWM control method for single-phase to three-phase converter with a three-phase switching power module," *Power Electronics Specialists Conference, 1998. PESC 98 Record. 29th Annual IEEE* , vol.1, no., pp.464-469 vol.1, 17-22 May 1998
- [12] Thida Win, Nang Sabai and Hnin Nandar Maung, "Analysis of Variable Frequency Three Phase Induction Motor Drive", World Academy of Science, Engineering and Technology 42, 2008
- [13] Tokuo Ohnishi, "PWM Control Method For Single-Phase to Three- Phase Converter with a Three- Phase Switching Power Module", 29th Annual IEEE PESC, Vol. 1, pp. 464-469, 1998.
- [14] Enjeti P. N. and Rahman A., "A new single-phase to three-phase converter with active input current shaping for low cost AC motor drives", *IEEE Trans. Industry Applications*, Vol. 29, pp. 806-813, August.1998.
- [15] Kazmierczuk, M.K., Czarkowski, D. & Thirunarayan, N., "A new phase-controlled parallel resonant converter", *IEEE Transactions on Industrial Electronics*, Vol. 40, pp. 542-552, Dec. 1993.
- [16] Siri, K.; Batarseh, I.; Lee, C.Q.; , "Small signal analysis of parallel resonant converters," *Circuits and Systems*, 1991., Proceedings of the 34th Midwest Symposium on , vol., no., pp.739-742 vol.2, 14-17 May 1991
- [17] Chaudhari, M.A.; Suryawanshi, H.M.; , "Single-Phase Resonant Converter with Active Power Filter," *Power Electronics, Drives and Energy Systems*, 2006. PEDES '06. International Conference on , vol., no., pp.1-6, 12-15 Dec. 2006
- [18] Kazmierczuk, M.K., Czarkowski, D. and Thirunarayan, N., "A new phase-controlled parallel resonant converter", *IEEE Trans. On Industrial Electronics*, Vol. 40, pp. 542-552, Dec.1993.
- [19] Siri, K., Batarseh, I. and Lee, C.Q., "Small signal analysis of parallel resonant converters", *Proceedings of the 34th Midwest Symposium on Circuits and Systems*, Vol. 2, pp. 739-742, May.1991
- [20] Carl Blake and Chris Bull, "IGBT or MOSFET: Choose Wisely", *International Rectifier*.

- [21] Mekhilef S. and Chandrasegaran D., "Assessment of Off-shore Wind Farms in Malaysia", IEEE Region 10 Conference, TENCON, Nov 2011, pp. 1351 - 1355.
- [22] Koh Siong Lee and Lim Yun Seng, "Preliminary Investigation of the Potential of Harnessing Tidal Energy for Electricity Generation in Malaysia", Transmission and Distribution Conference and Exposition, April 2008, pp. 1 - 7.
- [23] Available: <http://www.maxim-ic.com/app-notes/index.mvp/id/4266>
- [24] Enjeti, P. and Choudhury S.A. "A low cost single phase to three phase static power converter", IEEE 36th Annual Conference, Rural Electric Power Conference, May 1992, pp. A4/1 - A4/7.
- [25] Ferreira, F.J.T.E.; Fong, J.A.C.; de Almeida, A.T.; , "Ecoanalysis of Variable-Speed Drives for Flow Regulation in Pumping Systems," *Industrial Electronics, IEEE Transactions on* , vol.58, no.6, pp.2117-2125, June 2011

## APPENDICES

**APPENDIX A  
FLOW CHART**

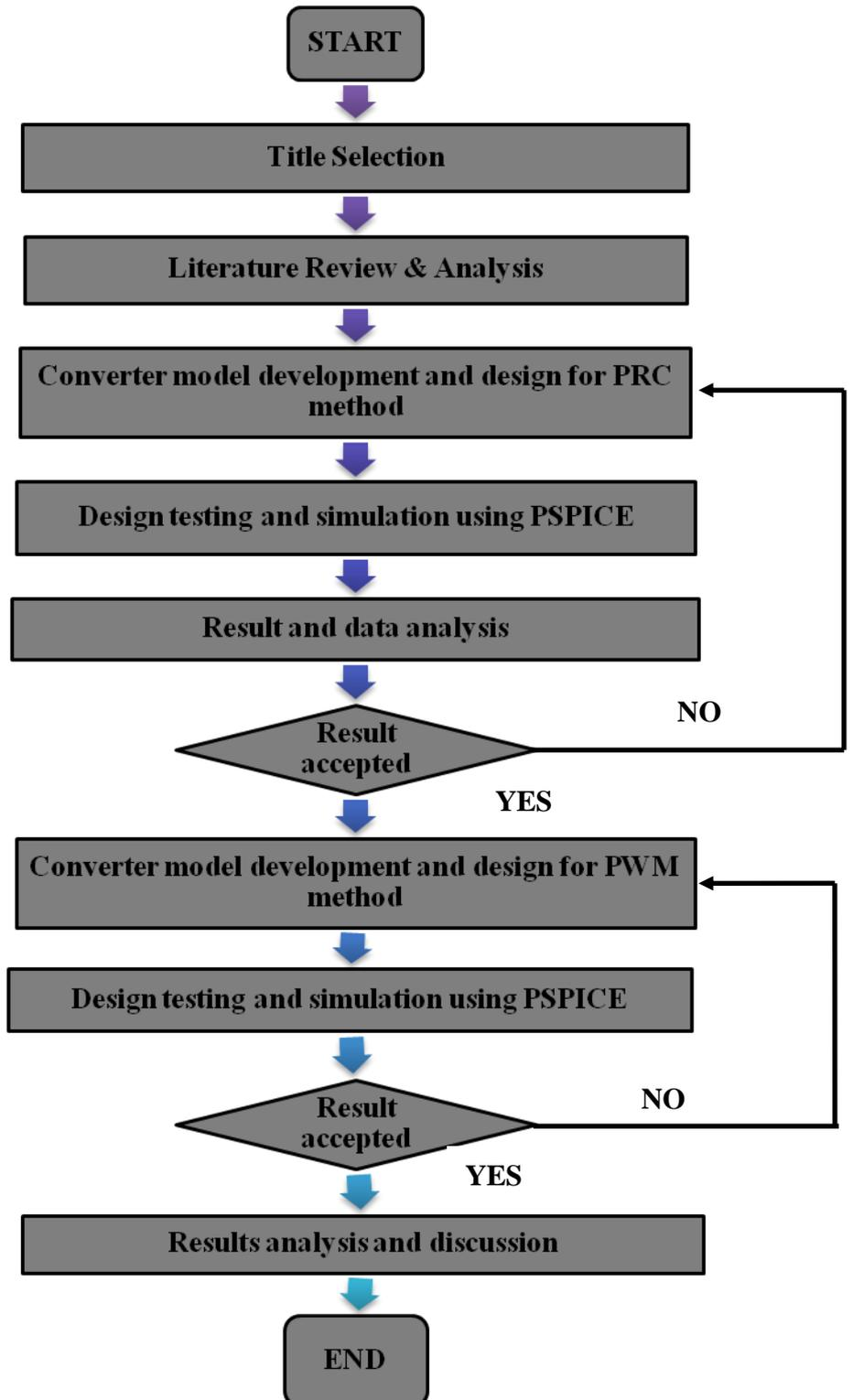

## APPENDIX B

### FYP TIMELINE

ACTIVITIES	FINAL YEAR PROJECT													
	WEEK NO.													
	1	2	3	4	5	6	7	8	9	10	11	12	13	14
<b>FYP1 timeline</b> 														
Title selection, research and literature review														
Extended proposal submission and proposal defense														
Design and develop converter model														
Submission of interim report														
 <b>FYP2 timeline</b>														
Construction of parallel resonant converter														
Modeling and simulation using PSPICE														
Model testing and data analysis														
Progress report submission														
Construction of second part of the project using PWM converter														
Modeling and simulation of PWM converter using PSPICE														
Model testing and data analysis on PWM converter														
Completion of converter design and testing														
Submission of draft report														
Submission of final report and technical report														
Project VIVA														