

**LIFTING WATER FROM WELL USING  
SOLAR ENERGY GENERATOR**

By

SITI MARYAM BINTI YAHAYA

FINAL REPORT

Submitted to the Electrical & Electronics Engineering Programme  
in Partial Fulfillment of the Requirements  
for the Degree  
Bachelor of Engineering (Hons)  
(Electrical & Electronics Engineering)

DECEMBER 2009

Universiti Teknologi Petronas  
Bandar Seri Iskandar  
31750 Tronoh  
Perak Darul Ridzuan

© Copyright 2009

by

Siti Maryam Yahaya, 2009

# **CERTIFICATION OF APPROVAL**

## **LIFTING WATER FROM WELL USING SOLAR ENERGY GENERATOR**

by

Siti Maryam Binti Yahaya

A project dissertation submitted to the  
Electrical & Electronics Engineering Programme  
Universiti Teknologi PETRONAS  
in partial fulfilment of the requirement for the  
Bachelor of Engineering (Hons)  
(Electrical & Electronics Engineering)

Approved:

---

Dr. Taj Muhammad Baloch

Project Supervisor

UNIVERSITI TEKNOLOGI PETRONAS  
TRONOH, PERAK

December 2009

## **CERTIFICATION OF ORIGINALITY**

This is to certify that I am responsible for the work submitted in this project, that the original work is my own except as specified in the references and acknowledgements, and that the original work contained herein have not been undertaken or done by unspecified sources or persons.

---

SITI MARYAM YAHAYA

## **ABSTRACT**

Water-lifting systems are used especially in rural areas to lift water from a well. The common device used in these rural areas is electrical pump. The electrical pump has taken a high cost due to the implementation of the transmission and also people need to pay for the monthly electric bills. Therefore, there is a need for improving water lifting using cheap solar energy generator. The main focus of this project is to construct a solar energy water lifting system that is clean, provide no pollution, simple and convenient. Step by step approach is applied in this engineering project so that the solutions are based on every single criterion that has been studied. The solar water pump consists of photovoltaic (PV) panel, power storage, charge controller, water level detector and DC submersible water pump. Studies in these fields are needed in order to make sure that the project is successful. The major part focused in this project is to design the overall system and make sure that the prototype of the system is working. Results of the simulation and experiments are included in the Result & Discussion chapter. The report contains five main chapters, namely Introduction, Literature Review, Methodology, Result and Discussion and Conclusion.

## **ACKNOWLEDGEMENTS**

First and foremost, I would like to express my gratitude to my Final Year Project 1 supervisor, Dr. Abdallah Belal Adam and also my Final Year Project 2 supervisor, Dr. Taj Muhammad Baloch, for their invaluable help, advices, suggestions, and encouragement. Their untiring effort has been a continuous inspiration to me.

My utmost and heartfelt thanks are to all the people who have spent time to support with me regarding the concept and methodologies of this project in order to smoothly understand and implement this project. I would like to thank the FYP technician, especially Mrs. Siti Hawa for helping me in preparing the entire necessary document in order to make sure that our final year project is running smoothly.

Most importantly, I would like to thank my parents who love me, support me and teach me to be a responsible and wise person. Their sacrifice and support throughout my life have helped me a lot in my education.

Last but not least, I would like to extend my appreciation to my classmates in University Technology Petronas (UTP), especially Mr. Izhan bin Ibrahim, who have support me morally throughout this project. I would also like to express my faithful thanks to all whose their name had not mention, but have either directly or indirectly assists me in this project. All your helps, kindness, valuable guidance and advice will never be forgotten.

# TABLE OF CONTENTS

ABSTRACT.....	v
ACKNOWLEDGEMENTS.....	vi
LIST OF FIGURES.....	ix
LIST OF TABLES.....	x
CHAPTER 1 INTRODUCTION .....	1
1.1 Background of Study.....	1
1.2 Problem Statement.....	2
1.3 Objectives.....	3
1.4 Scope of Study.....	3
CHAPTER 2 LITERATURE REVIEW .....	4
2.1 Solar Energy Sources .....	4
2.2 Overview of Photovoltaic System .....	5
2.3 Photovoltaic (PV) Cell .....	5
2.3.1 Types of the PV cells.....	6
2.3.2 Comparison of the Different Silicon Material.....	7
2.4 Power Storage.....	7
2.5 Charge Controller .....	8
2.6 DC Submersible Water Pump .....	9
2.7 Water Level Detector .....	9
CHAPTER 3 METHODOLOGY.....	10
3.1 Design Approach.....	10
3.2 Process Flow.....	11
3.3 System Design .....	12
3.4 System Sizing.....	12
3.4.1 DC Water Pump.....	12
3.4.2 PV Panel.....	13
3.4.3 Battery.....	13

3.5 Designing Charge Controller.....	14
3.6 Designing Water Level Detector .....	15
3.7 System Storage .....	16
3.8 Hardware .....	17
3.9 Software.....	17
<b>CHAPTER 4 RESULTS AND DISCUSSION .....</b>	<b>18</b>
4.1 PSpice simulation .....	18
4.1.1 Circuit of a single solar cell.....	18
4.1.2 Circuit of solar cells in series.....	19
4.1.3 Circuit of solar cells in parallel.....	19
4.2 Experimental Results.....	20
4.3 Designing Stages .....	21
4.3.1 Design of pumping system.....	21
4.4 Discussion.....	24
<b>CHAPTER 5 CONCLUSION AND RECOMMENDATION .....</b>	<b>25</b>
5.1 Conclusion.....	25
5.2 Recommendations .....	26
5.2.1 Improving the water level detector system.....	26
5.2.2 Improving the charge controller circuit.....	26
5.2.3 Adding second source at the input.....	26
<b>REFERENCES.....</b>	<b>27</b>
<b>APPENDICES.....</b>	<b>29</b>
Appendix A FYP I PROJECT MILESTONE .....	30
Appendix B FYP II PROJECT MILESTONE .....	31
Appendix C ENERGY SOURCES .....	32
Appendix D ENERGY CONSUMPTION IN MALAYSIA .....	33
Appendix E AVERAGE LOW PEAK SUN HOURS.....	34

## LIST OF FIGURES

Figure 1 : Simplified representation of a photovoltaic (PV) cell operation. ....	5
Figure 2 : Design Approach .....	10
Figure 3 : Process flow .....	11
Figure 4 : Block diagram of the overall system .....	12
Figure 5 : Schematic diagram of charge controller .....	14
Figure 6 : Schematic diagram of water detector .....	15
Figure 7 : Storage box schematic view .....	16
Figure 8 : Circuit with current-voltage value of a single solar cell.....	18
Figure 9 : Circuit with current-voltage value of two solar cells connected in series. ....	19
Figure 10 : Circuit with current-voltage value of two solar cells connected in parallel. ....	19
Figure 11 : Output of a single solar cell .....	20
Figure 12 : Output of two single solar cell connected in series .....	20
Figure 13 : First design of the output system .....	22
Figure 14 : Second design of the output system.....	22
Figure 15 : Third design of the output system .....	23



## LIST OF TABLES

Table 1 : Comparison of efficiency of three type photovoltaic silicon .....	7
Table 2 : DC Water pump specification .....	12
Table 3 : Battery specification .....	13
Table 4 : Average output from single solar cell .....	21
Table 5 : Output from two solar cells connected in series .....	21

# CHAPTER 1

## INTRODUCTION

### 1.1 Background of Study

Water is in liquid form contains hydrogen and oxygen (H<sub>2</sub>O). Pure water is an odorless, tasteless and clear liquid. It is one of nature's most important gifts to mankind. It is important for the daily life usage such as drinking, bathing, washing and etc. One of the sources of getting the water is from water well.

Water well is structure created in the ground by digging, driving, boring or drilling in order to access underground water. Lifting devices using electrical pump or mechanical pump can be used to raise the water from the well. It can also be drawn up using containers, such as buckets that are raised mechanically or by hand. Well water typically contains more minerals in solution than surface water. There are three types of the water wells which are Dug wells, Driven wells and Drilled well [1].

Dug wells are holes in the ground dug by shovel. In the developing countries, dug well uses hand pumped to lift water. But historically, a dug well was digging out below the groundwater table until incoming water exceeded the digger's bailing rate. Driven wells usually located in areas with thick sand and gravel deposits where the ground water table is within 15 feet of the ground's surface and typically 30 to 50 feet deep. Lastly, the Drilled wells can get water from a much deeper level (range from 20 to 600 feet) by mechanical drilling. Drilled wells with electrical pumps are currently used throughout the world [2].

Solar and wind energy is also used nowadays to generate electricity which supply energy to an electric pump to lift water. Solar generator is a device that generates the electrical power when the sunlight strikes the PV panel. PV cell is made up of two thin layers of a semi-conductor material appropriately doped with impurity atoms. When sunlight strikes the PV panel, the voltage will be producing. Most of the PV panel is made up from the silicon [3]. Details of the PV cell will be discussing later in Literature Review.

## **1.2 Problem Statement**

Nowadays, many water-lifting devices are used to lift water from a well to a height that allows users easily access to water. But, it is still not an easy task for the communities who are staying in places where an access to other potential water pumping power sources is constrained. Therefore, one of the common used devices in these rural areas is electrical pump.

The conventional electric supply from the supplier takes a high cost especially in rural area since there is a need to implement the transmission line, which enabled only to supply the electricity to these areas. People also need to pay for monthly electric bills. Due to this situation, there is a need for improving water lifting using solar energy generator which is cheaper in long term.

Solar water pump makes use of the solar energy that is clean, without pollution, simple and convenient. It solves the problem of water supply to agriculture irrigation, peoples and livestock and frontier defense sentry water supply in the region where there is no water and no electricity.

### **1.3 Objectives**

- To design solar energy water lifting system.
- To construct charge controller for the power storage.
- To install water level detector for the system.
- To construct the prototype of solar energy water lifting system.

### **1.4 Scope of Study**

The scopes of study of this project will emphasis on designing and creating a prototype for lifting water using solar energy generator. In order to make sure this project is successful, study in following field was carried out:-

- Basic idea of the solar energy.
- The operation of PV cell and conversion of solar energy to the electric.
- Concept of solar energy storage in the battery.
- Concept of charge controller in order to prevent over voltage for the power storage.
- Operation of the motor and direct current (DC).

## **CHAPTER 2**

### **LITERATURE REVIEW**

#### **2.1 Solar Energy Sources**

Appendix C shows that different types of energy sources are actually come from the sun and solar-driven processes. Fossil fuels are the remains of dead animal and plant matter that have been subject to extreme temperature and pressure over millions of years which are resulting from the solar energy falling on the earth. Biomass is a result of solar energy since the sun provides the solar energy to grow. For wind energy, wind is caused by air rushing from an area of high pressure to an area of low pressure (the changes in pressure are caused by the sun heating air).

Appendix D shows Malaysia gets most of its energy from fossil fuels, followed by nuclear, hydropower and other renewable energy. Fossil fuels increased amount of carbon dioxide in the atmosphere which has dire implications for the delicate balance of ecosystem and could eventually lead to runaway climate change. Same goes for nuclear power, it will also lead to the unbalanced of the ecosystem. Hydropower requires large inputs of electricity. On the other hand, the other renewable energy is clean, green, free and isn't going to be going anywhere for about the next five billion years which include thing such as solar power [4]. Due to all of the above reasons, it is proven that solar energy is one of the best energy sources to be used as an alternative energy.

## 2.2 Overview of Photovoltaic System

The solar pump that being designed is consist of PV panel, power storage, charge controller, water detector and submersible DC water pump. PV panel collects the solar energy and convert it to the DC current. The electric energy is then stored in the power storage battery. Charge controller is placed in between PV panel and the battery to avoid overcharging condition. Electric energy in the battery will be used to run the DC pump. Water detector in the storage tank will determine when the pump should run or stops operate.

## 2.3 Photovoltaic (PV) Cell

PV cell is a semiconductor device that can convert the sunlight direct to DC. PV cell is made up of two thin layers of a semi-conductors materials appropriately doped with impurity atoms so as to give one layer a negative electrical bias (n-bias) and the other a positive bias (p-bias). When sunlight strike the PV panel, the current (electron) will be produced. Figure 1 shows a simplified representation of a PV cell operation [5].

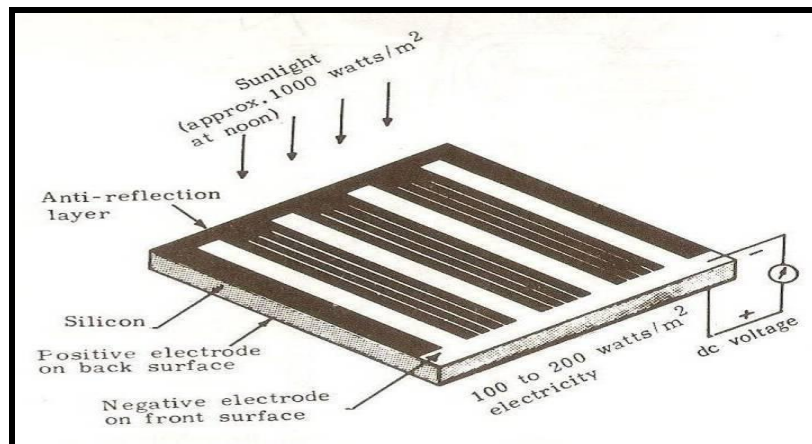

Figure 1 : Simplified representation of a photovoltaic (PV) cell operation.

### ***2.3.1 Types of the PV cells***

Most of the PV cells are made up from the silicon (sand). There are four types of the PV cells.

1. Monocrystalline silicon
2. Polycrystalline silicon
3. Ribbon silicon
4. Amorphous silicon

Most of PV cells are monocrystalline types. The cells have a uniform colors, usually blue or black. Normally, most of the cells had a slight positive electrical charge. Polycrystalline cells are manufactured and operate in a similar as single-crystal silicon. The different is lower cost silicon is used resulting the efficiency of the PV panel is slightly lower.

Ribbon-type photovoltaic cells are made by a growing ribbon from the molten silicon instead of an ingot. These cells are operating same as a single and polycrystalline cells. Amorphous silicon is sometimes abbreviated as “aSi” and is also called thin film silicon. The layers of the silicon allows some light to pass through, multiple layers can be deposited. The added layers increase the amount of the electricity the PV cells can provide [6].

### 2.3.2 Comparison of the Different Silicon Material

Table 1 [7] shows typical conversion efficiencies of silicon based on PV modules. A lower efficiency means more PV modules are needed for the same electricity output. Efficiency is a measurement of the electrical energy output from the module or the system as a fraction of the light energy (sunlight) input into the module system.

Table 1 : Comparison of efficiency of three type photovoltaic silicon

<b>Module</b>	<b>Amorphous</b>	<b>Monocrystalline</b>	<b>Polycrystalline</b>
<b>Typical efficiency</b>	3 – 6 %	12 – 15 %	10 – 13 %

### 2.4 Power Storage

A battery which is actually an electric cell is a device that stored and produces electricity from chemical reaction. A battery consists of two or more cells connected in series or parallel. It consists of a negative electrode, an electrolyte that conduct ions, a separator and a positive electrode. Solar battery will store the sun's energy that converts to electricity.



The common type of battery used is rechargeable battery. The advantage of this battery is it can discharge more of the stored energy and can maintain a long life. The automobile batteries are not suitable for this application because daily charge and discharge cycles greatly shorten their useful life [8].



Figure 2 : Rechargeable battery

## 2.5 Charge Controller

Batteries are known to have less storage space and the sun produces energy as long as it shines which may overcharge the battery. Charge controller is an important part in the solar pump motor which responsible to measure the amount of the voltage in the battery and at the same time to prevent the overcharging voltage by limiting the amount of voltage charge into the battery. The solar charge controller must matches battery's voltage in order to protect the battery.

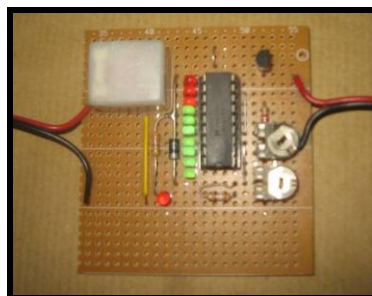

Figure 3 : Charge controller circuit

## 2.6 DC Submersible Water Pump

Pump is a device used to move fluids, such as gases, liquids or slurries. A pump displaces a volume by physical or mechanical action. Pumps alone do not create pressure; they only displace fluid, causing a flow. Adding resistance to flow causes pressure. Nowadays electrical water pump has become popular due to easy to install and use. Electrical pump usually comes with an AC power supply [9].



Figure 4 : DC water pump

## 2.7 Water Level Detector

Water level detector is a circuit of a sensor which can detect presence of water. Probe is used as water sensor. Water level detector is placed in the water storage tank, at one level (maximum), so that it can detect whenever the water exceed the level and activate a relay acts like a switch and is operated in normal close (NC) mode which means, contacts disconnect the circuit when the relay is activated; the circuit is connected when the relay is inactive [10].

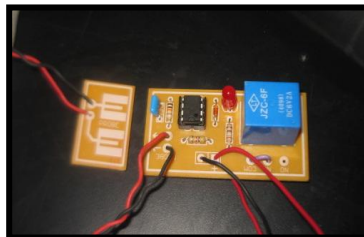

Figure 5 : DC water pump

# CHAPTER 3

## METHODOLOGY

### 3.1 Design Approach

At the early stage of this project, a step-by-step approach has been planned in order to complete the task. The project flow is shown in Figure 6 below:-

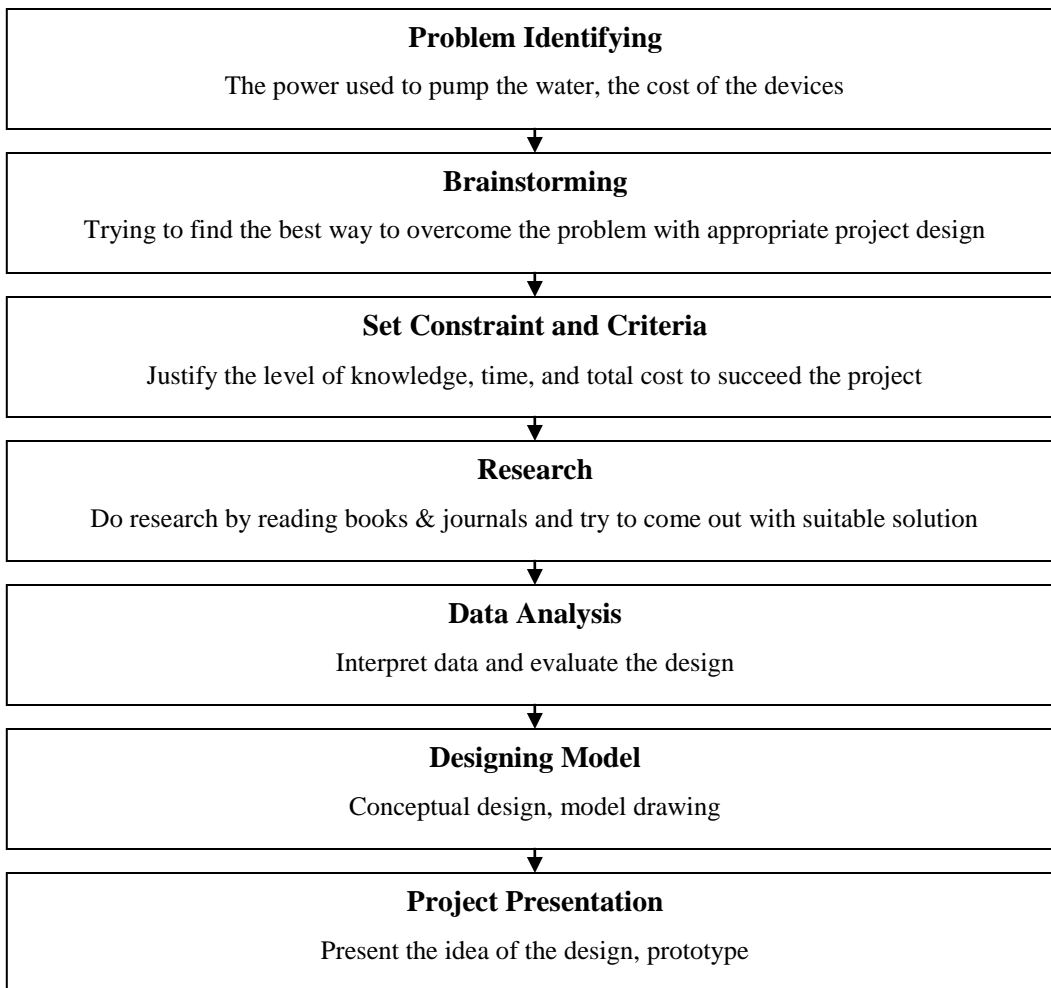

Figure 6 : Design Approach

### 3.2 Process Flow

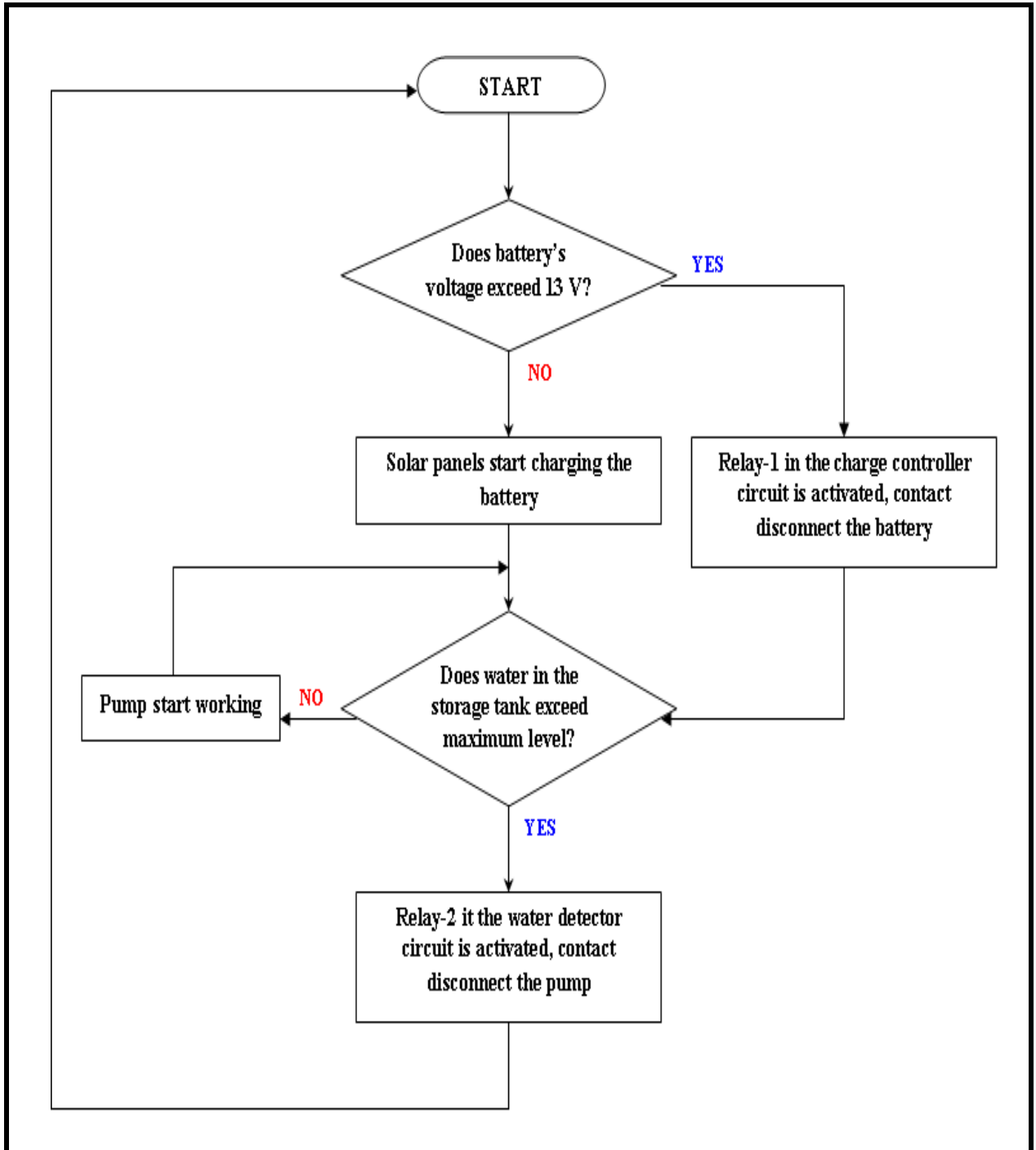

Figure 7 : Process flow

### 3.3 System Design

The overall system is shown in Figure 8. As mentioned earlier in Literature Review, the solar water pump consists of PV panel, charge controller, battery, water level detector and the DC water pump.

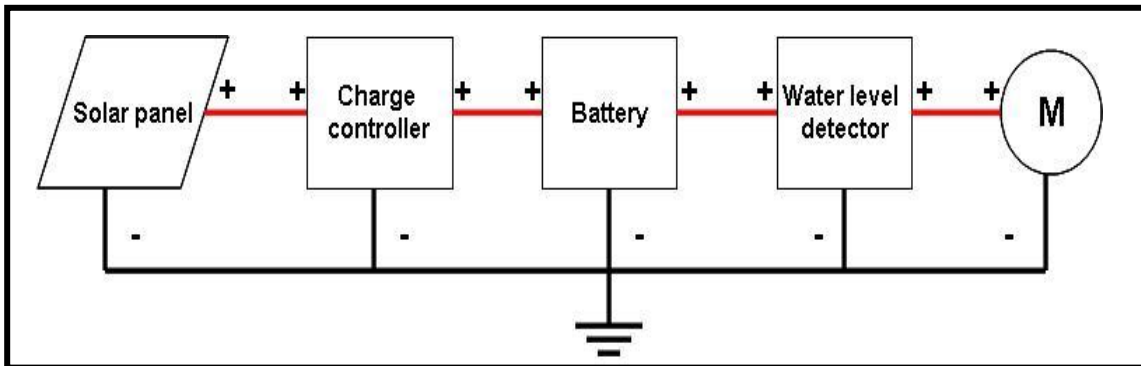

Figure 8 : Block diagram of the overall system

### 3.4 System Sizing

#### 3.4.1 DC Water Pump

Pump specification are shown in Table 2:

Table 2 : DC Water pump specification

<b>Voltage</b>	8 V
<b>Current</b>	0.9 A
<b>Power</b>	7.2 W

Assume pump will operate for 1 hour per day;

Total energy consumed = 7.2 W x 1 hour = **7.2 Watt hour per day**

### 3.4.2 PV Panel

From the Appendix B, average peak shine Malaysia is 4-5 hours per day.

Assume average peak shine = 4 hours per day

Required solar panel input = 7.2 Watt hour/ 4 hours = **1.8 W**

### 3.4.3 Battery

Table 3 : Battery specification

<b>Voltage</b>	12 V
<b>Ampere hours</b>	3.2 AH
<b>Current</b>	166.67 mA

Assume battery running for 4 hours per day

Number of hours battery can operate without recharging = 3.2 AH/ 166.67 mA = **19.2 Hours**

### 3.5 Designing Charge Controller

In this system, voltage indicator circuit is used as a charge controller. The main component in the voltage indicator circuit is the LM3914 IC. The LM3914 IC is a small integrated circuit that senses analog voltage levels and drives 10 LEDs, providing a linear analog display. Each LED indicates voltage level of the battery range from 10V to 14.5V.

Modification of the voltage indicator circuit is made with the additions of relay and diodes. The solar panel in the system is connected with the blocking diode. It is because the system includes a battery storage system where a reverse flow of current from the batteries through the PV array can occur. This flow will drain power from the batteries. Diodes used to stop this reverse current flow. On the other hand, relay contacts disconnect the circuit when battery's voltage reached 13V in order to avoid overcharging voltage to the battery.

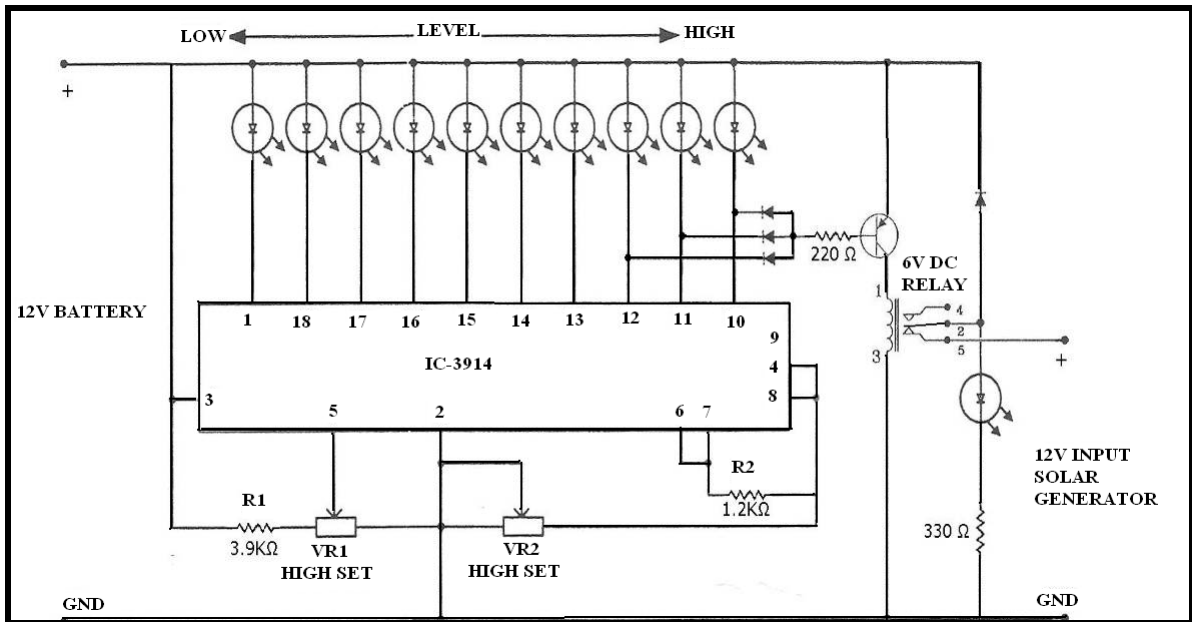

Figure 9 : Schematic diagram of charge controller

### 3.6 Designing Water Level Detector

Water level detector used to detect the presence of water at the maximum level in the water storage tank. The importance of having water detector is to prevent the overflow of the water and to optimize the use of DC water pump (pump only running when no water in the storage tank until water reaches the maximum level).

The IC 555 is a highly stable controller capable of producing accurate time delays, or oscillation. Probe is used as a water sensor. Relay will act like a switch and is operated in normal close (NC) mode. When no water detected by probe, relay is inactive (relay contact connect the circuit) which result the pump to operate. On the other hand, when water is detected, relay is activated (relay contacts disconnect the circuit) result the pump to stop operate. Schematic diagram of the water detector is shown in the Figure 10.

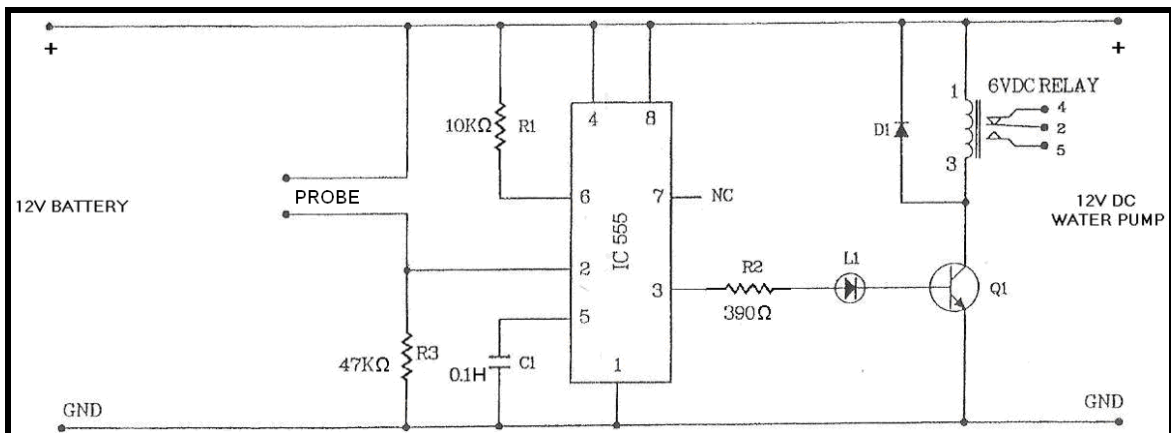

Figure 10 : Schematic diagram of water detector



### 3.7 System Storage

Battery and circuit need to have a proper storage in order to prevent them from damages. Figure 11 below shows the storage box for the battery and circuit.

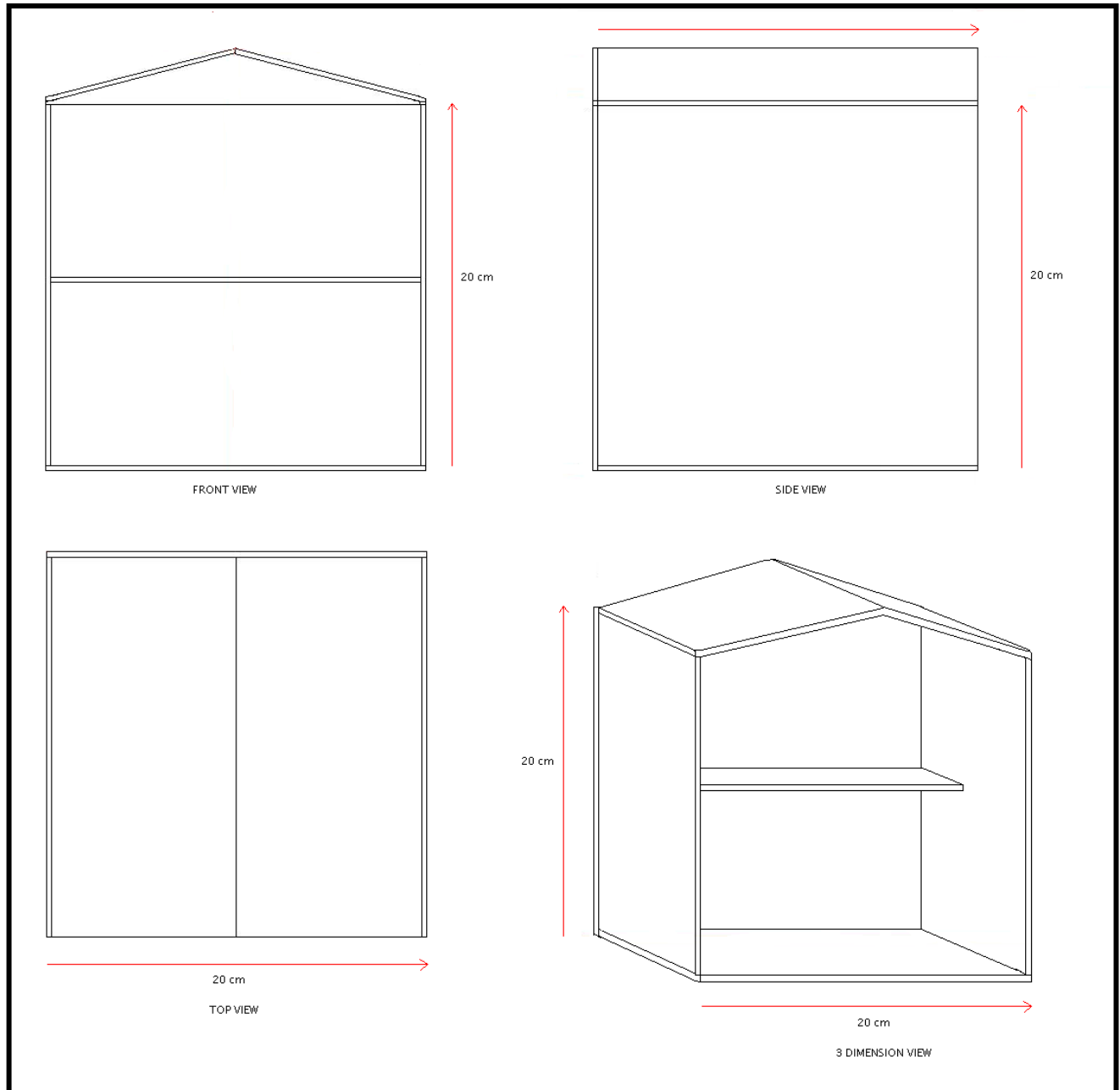

Figure 11 : Storage box schematic view

### **3.8 Hardware**

Tools of this project have been defined after defining the objectives and the project works. Below are the hardware used for this project:

1. PV Panel (Two PV panel of 7.5 V, 135 mA, connected in series)
2. Power Storage/ Battery (12 V, 3.2 AH)
3. 12 V DC Submersible water pump
4. Water Level Detector

### **3.9 Software**

1. Microsoft Word
2. Microsoft Power Point
3. Pspice
4. Microsoft Paint
5. Microsoft Publisher

## CHAPTER 4

### RESULTS AND DISCUSSION

#### 4.1 PSpice simulation

Individual PV panel can be wired in series or parallel to obtain the required voltage or current needed to charge the battery. PSpice simulation is an important step before proceed with the prototype fabrication. Results show the expected value of voltage and current for a single solar cell, two solar cells in series and two solar cells in parallel.

##### 4.1.1 Circuit of a single solar cell

From the simulation, 7.5 V of a solar cell connected in series with a 1 k $\Omega$  resistor, R1, produced 7.5 V voltages, 7.5 mA current.

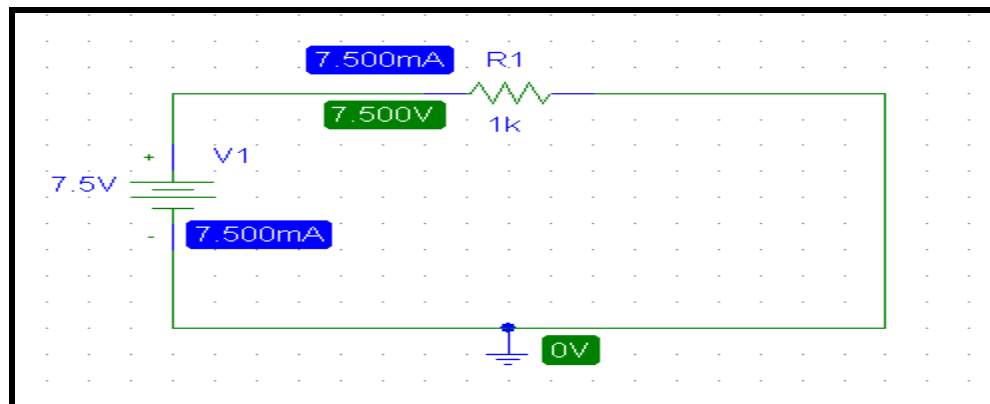

Figure 12 : Circuit with current-voltage value of a single solar cell

### 4.1.2 Circuit of solar cells in series

Next, two 7.5 V of a single solar cell connected in series. The connection of several solar cells is known as a PV panel. PV panel is then connected in series with a 1 k $\Omega$  resistor, R1. The PV panel produced 15 V voltage and 15 mA current at the output.

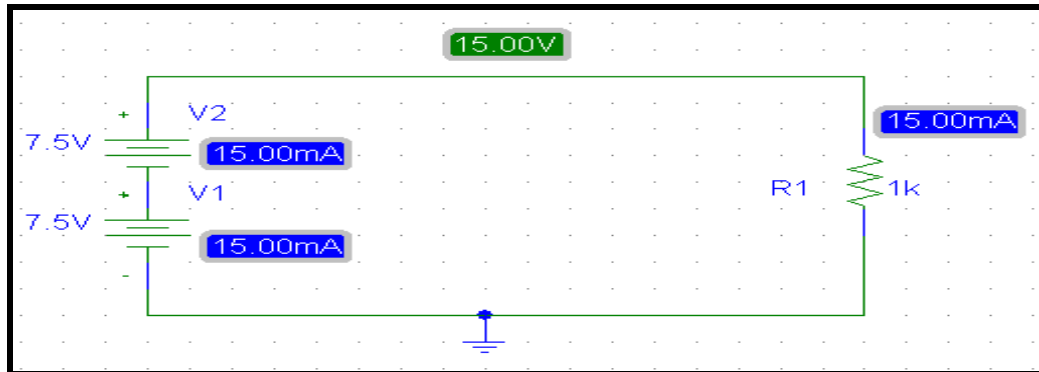

Figure 13 : Circuit with current-voltage value of two solar cells connected in series.

### 4.1.3 Circuit of solar cells in parallel

Lastly, two 7.5 V of a single solar cell connected in parallel. Result shown 7.5 V voltage and 22.5 mA current produced at the output.

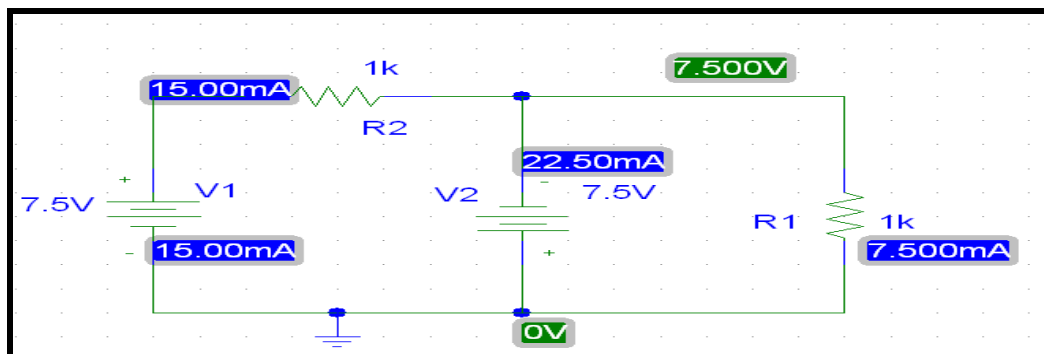

Figure 14 : Circuit with current-voltage value of two solar cells connected in parallel.

## 4.2 Experimental Results

Experimental value of the output of PV panel has been recorded for 5 days and results has been recorded in a graph as shown in Figure 15 and Figure 16 below:-

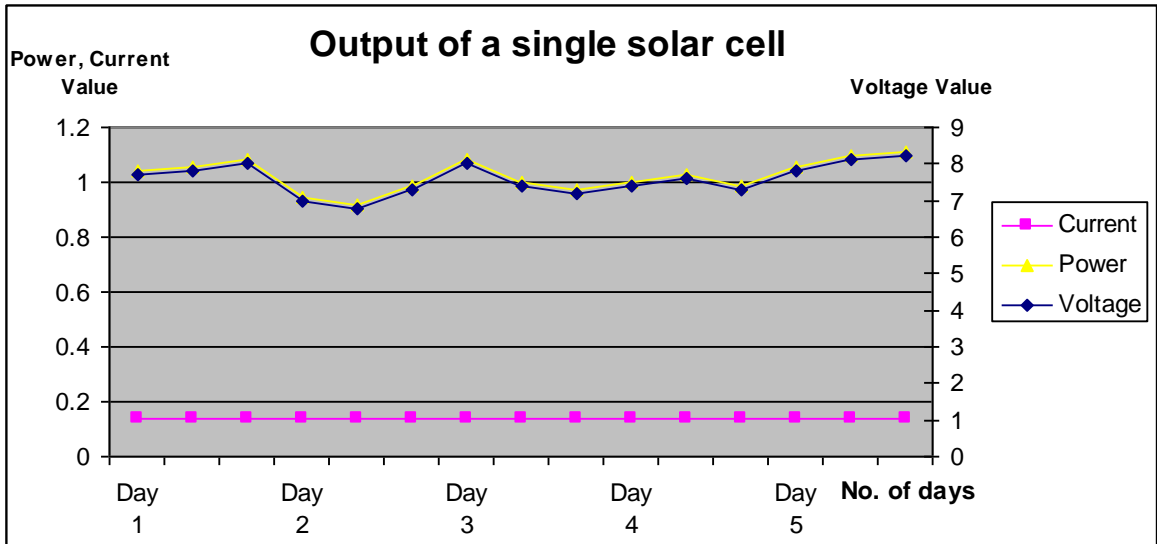

Figure 15 : Output of a single solar cell

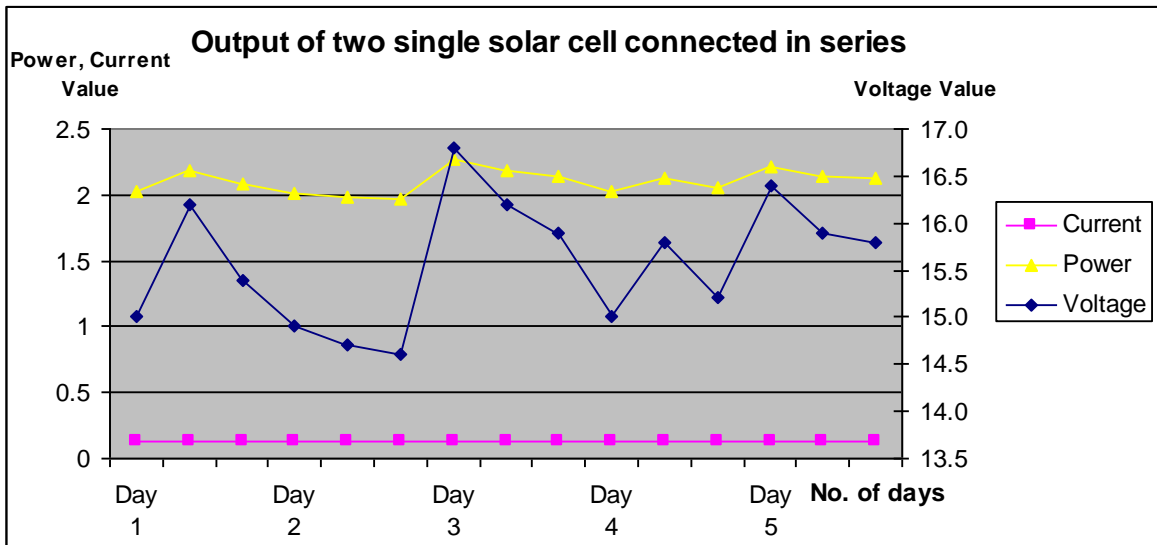

Figure 16 : Output of two single solar cell connected in series

Table 4 and Table 5 below recorded the average output of single solar cells and two single solar cells connected in series:-

Table 4 : Average output from single solar cell

<b>Average voltage</b>	7.6 V
<b>Average current</b>	135 mA
<b>Average power</b>	1.03 W

Table 5 : Average output from two solar cells connected in series

<b>Average voltage</b>	15.6 V
<b>Average current</b>	135 mA
<b>Average power</b>	2.11 W

### 4.3 Designing Stages

#### 4.3.1 Design of pumping system

The first design of connecting the water pump, water detector level and the batteries is shown in the Figure 17 below. All the three components are connected in series. The problem occurred that the water pump was not working due to low current flowing through the pump.

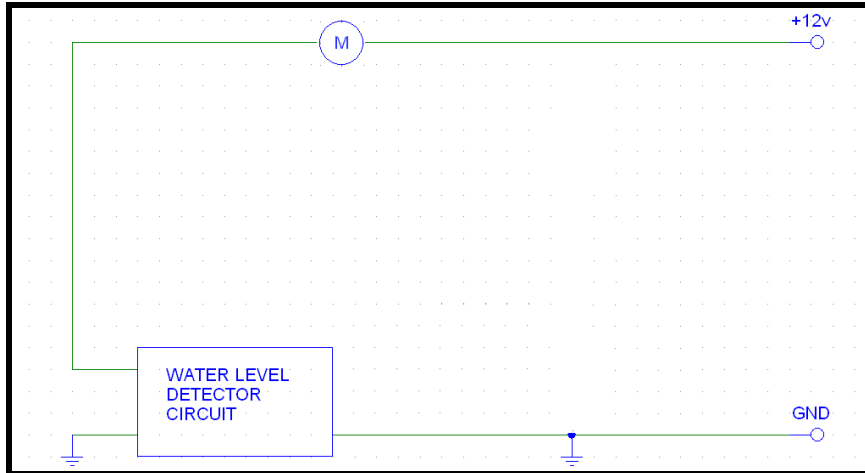

Figure 17 : First design of the output system

Since the problem of the first design was due to low current flowing through the pump, NPN transistor has been added to the original design. The main purpose of this transistor is to amplify or switch electronic signal. A voltage or current applied to one pair of the transistor's terminals changes the current flowing through another pair of terminals. Because the controlled (output) power can be much more than the controlling (input) power, the transistor provides amplification of a signal.

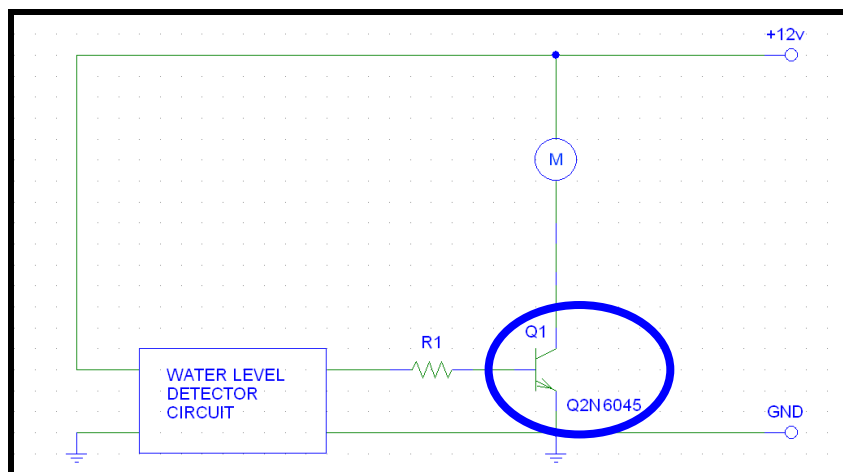

Figure 18 : Second design of the output system

Pump in the second design was working but only for a few seconds. A further analysis has been carried out and the problem has been determined; there is a reverse flow of current from the motor (everytime the battery is disconnected). As a countermeasure, diodes used to stop this reverse current flow.

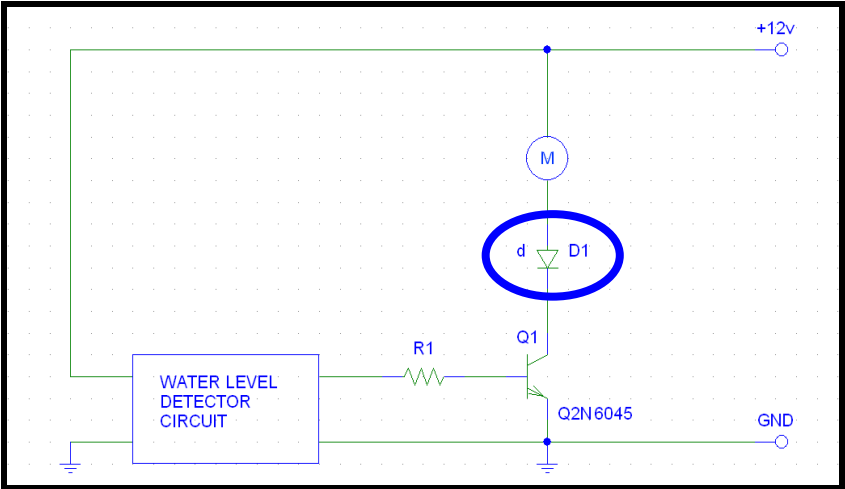

Figure 19 : Third design of the output system



#### 4.4 Discussion

As known from the theory, the voltage output from cells wired in series is the sum of all the voltages from the cells. After doing the simulation with PSpice and running the experiment, it is proven that the voltages of the output came from the summation of the two solar cells while the amount of current maintain the same (equal to single solar cell).

In case solar cells connected in parallel, the voltage output from cells wired in parallel is the same value of the voltage from the single solar cell. Meanwhile, the current (amps) output is the sum of all the currents (amps) from the panels. Simulation and experimentation results proved the theory.

For the system part, since the pump does not need to operate for 24-hours per day, therefore, water level detector is used to disconnect the circuit whenever the water in the storage tank is full. Charge controller used in between PV panel and battery to monitor the charging voltage plus to prevent battery from overcharging. Final focus was made to complete prototype by the end of the semester.

Several difficulties have been faced throughout the semester. At the beginning of the semester, AC water pump has been considered to use as a load (output) in the system. Since the PV panel (input) produced DC output voltage, inverter is used to convert from DC to AC. Unfortunately; the output power from the inverter is too small (did not support the pump). As an alternative, DC pump has been used instead of AC pump.

Another difficulty was when connecting the battery, DC water pump and water detector level. Several experiment needed to be carried out in order to find the successful way to connect all the things together. As a countermeasure, NPN transistor with blocking diode at the transistor has been used.

## **CHAPTER 5**

### **CONCLUSION AND RECOMMENDATION**

#### **5.1 Conclusion**

Most of the work carried out was follow the time frame. The concept of each part (PV panel, power supply, charge controller, water detector and DC water pump) used in this project has been studied. The studies are done continuously throughout this two semesters. The prototype of the project is implemented this semester. Project is completed in two semester courses.

All of the project's objectives have been achieved, which were to design the solar water lifting system, to construct charge controller for the power storage, to construct water level detector for the pump and to construct the prototype of solar energy water lifting system. Studies the operations of the charge controller and the water detector circuit have been done. Circuits also have been designed and implemented.

Step by step approach is applied in this engineering project so that the solutions are based on every single criterion that has been studied. As a conclusion, the project is found to be successful although there are some difficulties in order to complete this project. Hopefully, this project will help the communities from the rural areas to solve their problems regarding water lifting someday.

## 5.2 Recommendations

Due to limited resources and time constraints, the study in this project is not fully completed. Several points should be included to improve the performance of this project. Therefore, the following suggestions are recommended for further study:

### 5.2.1 *Improving the water level detector system*

Currently, there is only one probe in the water storage tank. Pump will keep running starting from empty water until the water level reach maximum (where probe has been placed). In order to increase the life span of the pump, another probe should be added in the water storage tank. This probe will be placed at a certain minimum level so that pump only start to operate whenever the water level exceed the minimum level of the probe, and will stop operate whenever the water lever exceed the maximum level of the probe.

### 5.2.2 *Improving the charge controller circuit*

For this project, the charge controller functions as the voltage indicator and at the same time, also to prevent the overcharging voltage by limiting the amount of voltage charge to the battery. The improved charge controller must be able to choose the operation whether to charge the battery or to directly supply the power to the pump whenever the battery voltage exceeded cutoff value. Hopefully, the improvement of the circuit can make this project is become much better.

### 5.2.3 *Adding second source at the input*

Solar panel only produces voltage when there is sunlight. In order to improve the input power to the source, adding another source such as wind turbine which will boost up the input power.

## REFERENCES

- [1] Wikipedia. Water well. Retrieved February, 2009 from [http://en.wikipedia.org/wiki/Water\\_well](http://en.wikipedia.org/wiki/Water_well)
  
- [2] Epa.gov. *Wells type*. Retrieved February, 2009 from [http://www.epa.gov/ogwdw/privatewells/basic\\_dug.html](http://www.epa.gov/ogwdw/privatewells/basic_dug.html)
  
- [3] Patel Mukund R, *Wind and Solar Power System: Design, analysis and operation*. Boca Raton: CRC Press, 2005.
  
- [4] Gavin D.J. Harper, *Solar Energy Projects for the Evil Genius*. The McGraw-Hill Companies, Inc, 2007.
  
- [5] A M Michael & S D Khepar, *Water well and pump engineering*. Tata McGraw-Hill Publishing Company Limited, 1989.
  
- [6] Hazle bin Ibrahim, *Solar Pump Motor for Irrigation in Rural Areas*. FYP Final Report. 2004.
  
- [7] Ameco TM. *Types of solar electric system*. Retrieved on March, 2009 from <http://www.solarexpert.com/pvtypes.html>
  
- [8] Free Sun Power. *Basic tutorials*. Retrieved on March, 2009 from <http://www.freesunpower.com>
  
- [9] Wikipedia. *Pump and Applications*. Retrieved on February, 2009 from <http://en.wikipedia.org/wiki/Pump>

- [10] Wikipedia. Relay. Retrieved on 20 August, 2009 from <http://en.wikipedia.org/wiki/Relay>
- [11] Luis Castaner and Santiago Silvestre. *Modeling Photovoltaic System Using Pspice*. John Wiley & Sons Ltd, 2002.
- [12] Wirefreedirect. *Sizing a Solar Photovoltaic (PV) Array and System*. Retrieved on April, 2009 from [http://www.wirefreedirect.com/solarpanel\\_sizing.asp](http://www.wirefreedirect.com/solarpanel_sizing.asp)
- [13] Sol\_lite (M) Sdn. Bhd. *Solar Power System*. Retrieved on May, 2009 from [http://www.sol\\_malaysia.com/index.html](http://www.sol_malaysia.com/index.html)
- [14] OtherPower.com (2009). Wind charge controller. Retrieved on April, 2009 from <http://www.fieldlines.com/story/2004/9/20/0406/27488>
- [15] FAO Corporate Document Repository. 1986. *Water lifting devices*. Retrieved on February, 2009 from <http://www.fao.org/docrep/010/ah810e/AH810E03.htm>
- [16] Ursula Eicker. *Solar Technologies for Buildings*. John Wiley & Sons Ltd, 2003.
- [17] World Resource Institute *Energy and Resources Country Profile – Malaysia*. Retrieved on August 9, 2009 from <http://earthtrends.wri.org/text/energy-resources/country-profile-114.html>
- [18] Solar4Power. *Global Solar Power Map*. Retrieved on May, 2009 from <http://www.solar4power.com/map7-global-solar-power.html>

## APPENDICES

## APPENDIX A

### FYP I PROJECT MILESTONE

No.	Detail/ Week	1	2	3	4	5	6	7	8	9		10	11	12	13	14	
1	Selection of Project Topic										Mid-Semester Break						
2	Preliminary Research Work																
3	Submission of Preliminary Report				●												
4	Seminar 1 (optional)																
5	Project Work																
6	Submission of Progress Report								●								
7	Seminar 2 (compulsory)																
8	Project work continues																
9	Submission of Interim Report Final Draft															●	
10	Oral Presentation																●

Indication:

●	Suggested milestone
	Process

## APPENDIX B

### FYP II PROJECT MILESTONE

No.	Detail/ Week	1	2	3	4	5	6	7	8	9		10	11	12	13	14	
1	Project Work Continue										Mid- Semester Break						
2	Submission of Progress Report								●								
3	Seminar																
4	Project work continue																
5	Poster Exhibition												●				
6	Submission of Dissertation (soft bound)																●
7	Oral Presentation																●
8	Submission of Project Dissertation (Hard Bound)																●
		Indication:															
		●	Suggested milestone														
			Process														



## APPENDIX C

### ENERGY SOURCES

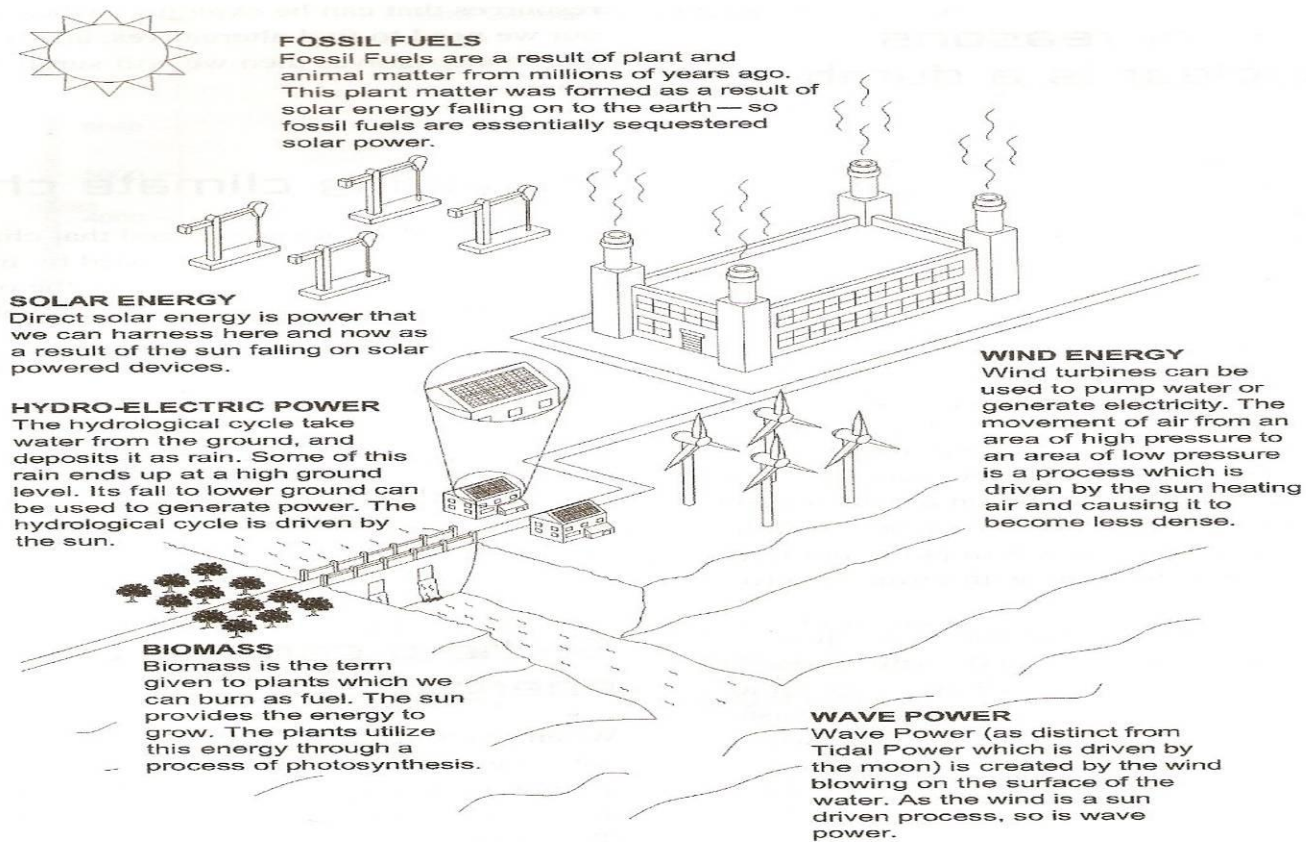

APPENDIX D  
ENERGY CONSUMPTION IN MALAYSIA

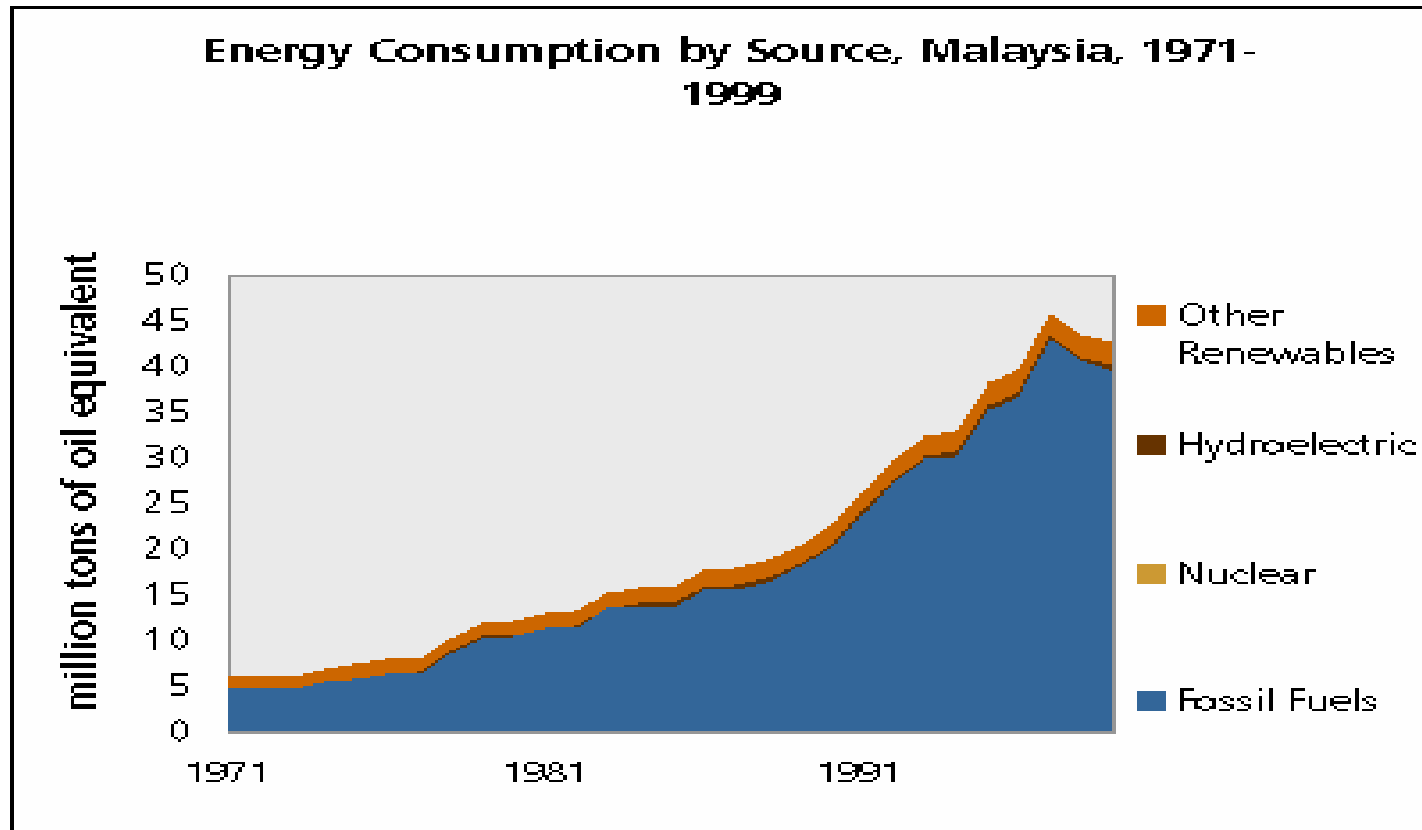

**APPENDIX E**  
**AVERAGE LOW PEAK SUN HOURS**

