

**BATTERY PERFORMANCE MONITORING IN  
PHOTOVOLTAIC ELECTRICITY GENERATION SYSTEM  
(PVEGS)**

By  
ZAINUL ARIFFIN BIN ABD RAHMAN  
Final Report

A project dissertation submitted to the  
Electrical and Electronics Engineering Programme  
Universiti Teknologi PETRONAS  
In partial fulfillment of the requirement for the  
Bachelor of Engineering (Hons)  
(Electrical & Electronics Engineering)

Universiti Teknologi PETRONAS  
Bandar Seri Iskandar  
31750 Tronoh  
Perak Darul Ridzuan

Copyright of 2013  
By  
Zainul Ariffin Abd Rahman 2013

**CERTIFICATION OF APPROVAL**

**BATTERY PERFORMANCE MONITORING IN PHOTOVOLTAIC  
ELECTRICITY GENERATION SYSTEM (PVEGS)**

By

Zainul Ariffin Bin Abd Rahman

A project dissertation submitted to the  
Electrical and Electronics Engineering Programme  
Universiti Teknologi PETRONAS  
In partial fulfillment of the requirement for the  
Bachelor of Engineering (Hons)  
(Electrical & Electronics Engineering)

Approved by:

.....

(A.P. DR BALBIR SINGH)

Project Supervisor

## **CERTIFICATION OF ORIGINALITY**

I hereby verify that this report was written by me, Zainul Ariffin Bin Abd Rahman (12232). I am responsible for the work that I have submitted in this project. The procedures and results achieved throughout the project were conducted with my own effort except as specified in the reference and acknowledgement.

.....  
(ZAINUL ARIFFIN BIN ABD RAHMAN)

## **ABSTRACT**

Generation of electricity is dependent on combustion of fossil fuels such as natural gas and coal. The emissions from the combustion of fossil fuels have led to serious environmental and climatic problems such as global warming and air pollution. The problems associated with fossil fuels initiated the interest to explore alternative energy sources that are more environmentally friendly and sustainable for electricity generation. One of the alternatives is using Photovoltaic Electricity Generation System (PVEGS). This project presents Battery Monitoring Performance in PVEGS. This PVEGS consist of 4 basics elements, which are PV arrays, loads, charge controller, auxiliary energy system and battery banks. This project shows the important of battery monitoring in PV EGS. Energy storage is a fundamental and critical part of any practical PV system, and involves the storage of excess PV-generated power in a form suitable for use during periods when the solar input is insufficient to support load demands. A monitoring mechanism is designed by using simulation in Pspice and Arduino microcontroller board. This project emphasize on battery monitoring based on voltage, current, age and functionality of each battery in battery bank.

## TABLE OF CONTENTS

LIST OF TABLES .....	vii
LIST OF FIGURES .....	viii
<b>CHAPTER 1 INTRODUCTION .....</b>	<b>1</b>
1.1 Project Background .....	1
1.1.1 Significant of the Project .....	2
1.2 Objective .....	2
1.3 Scope of Study .....	3
1.4 The Relevancy of the Project .....	3
1.5 Feasibility of the Project within the Scope and Time frame .....	3
<b>CHAPTER 2 LITERATURE REVIEW .....</b>	<b>4</b>
2.1 Solar Energy .....	4
2.1.1 Energy From The Sun.....	4
2.1.2 Issue In PV Electric Generation System.....	7
2.2 PV Electric Generation System.....	8
2.2.1 PV Array .....	8
2.2.2 Inverter/Charge Controller.....	10
2.2.3 Auxiliary .....	10
2.2.4 Battery Bank .....	10
2.2.5 Load .....	12
2.3 Battery Monitoring.....	12
2.3.1 Type of batteries .....	13
2.3.2 Common batteries in PVEGS .....	14
2.3.3 Issues Using Battery .....	15
<b>CHAPTER 3 METHODOLOGY .....</b>	<b>16</b>
3.1 Research Methodology.....	16
3.2 Project Duration .....	17
3.3 Tools.....	19
<b>CHAPTER 4 RESULTS AND DISCUSSION.....</b>	<b>20</b>
4.1 Problems regarding battery .....	20

4.2 Proposed Design.....	20
4.2.1 Design Methodology .....	21
4.2.2 Battery Performance Monitoring in PVEGS .....	22
4.3 Project hardware.....	23
4.3.1 Voltage sensor .....	23
4.3.2 Current sensor .....	24
4.3.3 Temperature and humidity sensor .....	24
4.3.4 Liquid Crystal Display.....	25
4.3.5 Battery.....	25
4.3.6 Battery monitoring prototype .....	26
4.4 Results .....	27
<b>CHAPTER 5 CONCLUSION AND RECOMENDATIONS .....</b>	<b>30</b>
5.1 Conclusion.....	30
5.2 Recommendation.....	30
<b>REFERENCES.....</b>	<b>31</b>

## LIST OF TABLES

Table 1 : Comparison between the type of PV arrays.....	9
Table 2 :Efficiency of difference cell type.....	9
Table 3: Examples of each type of batteries .....	13
Table 4 : Common batteries in PVEGS .....	14
Table 5 : Issues regarding batteries and its impacts.....	15
Table 6: Gantt Chart.....	18
Table 7: Result of damage batteries in random.....	20
Table 8: Parameter that will be monitored by the system.....	22
Table 9 : Values of components in voltage divider .....	23
Table 10 : Battery Specifications .....	25

## LIST OF FIGURES

Figure 1 : The radiation of sun through the atmosphere .....	5
Figure 2 : Fluctuations in consumption and PV electricity over the day in Japan.....	6
Figure 3 : Inclination and rotational of Earth that affect the PVEGS .....	7
Figure 4 : PV electric generation component.....	8
Figure 5 : Batteries bank .....	11
Figure 6 : Parallel connection of the battery bank .....	11
Figure 7: Series connection of the battery bank.....	11
Figure 8: Research Methodology .....	16
Figure 10 : Battery Performance Monitoring in PVEGS mechanism.....	21
Figure 11 : Proposed batteries performance monitoring system.....	22
Figure 12 : Voltage divider .....	23
Figure 13 : BB ACS 756 current sensor .....	24
Figure 14 : DHT11 Temperature & Humidity Sensor .....	24
Figure 15 : 16x2 Liquid Crystal Display .....	25
Figure 16 : NP7-12 Sealed Rechargeable Battery .....	25
Figure 17 : Circuit Diagram of Battery Monitoring.....	26
Figure 18 : Battery Monitoring Prototype.....	26
Figure 19 : Display Voltage of the Battery .....	27
Figure 20 : Display Current of the Battery.....	27
Figure 21 : Display Temperature Surrounding the Battery.....	28
Figure 22 : Display Humidity Surrounding the Battery.....	28
Figure 23 : Display Light Intensity Surrounding the Battery .....	29



# **CHAPTER 1**

## **INTRODUCTION**

Energy is a fundamental part of our lives and is essential to the economic and social sustainability of a nation. One of the most important energy conversions is for electrical power generation and is often correlated to a better quality of life. Fossil fuels have been used to generate electricity until now, but concerns tied to these fuels are raising the interest in the utilization of renewable energy resources such as solar energy for electricity generation.

### **1.1 Project Background**

Fossil fuels have been used to generate electricity until now, but concerns tied to these fuels are raising the interest in the utilization of renewable energy resources such as biomass, solar, wind, geo thermal and wave. Compare to the various renewable energy technologies of sustainable energy sources, photovoltaic (PV) appears quite attractive to be developed for electricity generation because it is noiseless, used safe source from the sun, no carbon dioxide emission during operation, scale flexibility and rather simple operation and maintenance. The photovoltaic power system has received considerable attention for the clean energy resource to solve the environmental problem in the worldwide scale

Basically, PV electric generation system is still new and still on research. Although it has been found about several decades ago, it is still not used widely in any country. The main component of PV electric generation can be simplified into five parts. The PV array cells, charge controller, load, battery bank and auxiliary energy. Most of the research and development will be focusing to the PV array cells, charge controller, load, and auxiliary system of the PV electric generation. Apart from the developing and enhancing the other components of the PV electric generation, battery in this system also should be noticed.

### **1.1.1 Significant of the Project**

PV electric generation is a system that will convert solar radiation into electric energy. This system will be used for a long period of time. Without a proper maintenance of the system, the PV electric generation will produce an unstable output and the system is not in optimized conditions.

The focus of the project is to make a monitoring system to look for the performance of the batteries. If there a failure in battery bank, the PV electric generation will be useless during non-existent of the solar radiation especially at night.

## **1.2 Objective**

The objectives of this research work are:

- To design a battery bank performance monitoring system for solar electricity generation system.
- To fabricate the battery bank performance monitoring prototype.

### **1.3 Scope of Study**

This project focuses on the battery performance monitoring. The scope of work throughout this research includes literature review related to the PV electric generation system and also the important of battery monitoring. Next will be the theoretical development focusing on the circuit connected with the battery and learning about the capability of the Microcontroller. Microcontroller will be used as the main component of this project as it will integrate the entire PV electric generation system component. The microcontroller also will be designed to add extra functions to monitoring the battery performances. After that, the circuit and battery monitoring design is simulated. A prototype of the PVEGS is implemented based on 12 volts battery and is tested.

### **1.4 The Relevancy of the Project**

Since the battery bank is one of the main components in PV electric generation system, battery monitoring is very important as it will show current battery performance. This project also will help in determining the voltage and current of the batteries.

### **1.5 Feasibility of the Project within the Scope and Time frame**

The project has been completed in two semesters which include four areas which are research, designing, fabricating and also improvement of the model itself. Most of the time will be consumed to make the best design and fabricating the model. The designing stages are using Arduino and Pspice software, and fabricating is related to the parts and equipment available in the laboratory. This project will be feasible to be carried out within the time frame

## **CHAPTER 2**

### **LITERATURE REVIEW**

All the important aspect of the PVEGS is thoroughly investigated and discussed here. This chapter is organized by describing the solar energy, the typical PVEGS then the important of battery monitoring.

#### **2.1 Solar Energy**

Solar energy is a radiant light and heat from the sun. The earth's surface receives an enormous amount of energy from the sun daily. The optimum performance of each of the PV electric generation system components relies on the careful assessment of the solar radiation incident at the site. Therefore, thorough understanding of the solar radiation's properties is contingent for maximum utilization of the energy resource available at a particular site.

##### **2.1.1 Energy From The Sun**

The earth received about  $4.2 \times 10^{18}$  Watt hours or  $1.5 \times 10^{22}$  Joules (or  $6.26 \times 10^{20}$  Joules per hour)[1] from the sun. A PV electric generation system is considered as the most dominant source among renewable energy technologies because it can supply unlimited and clean energy from the sun[2]. Many studies show that PV electric generation systems will have an important share in the electricity of the future as the sun is a non-deplete power source.

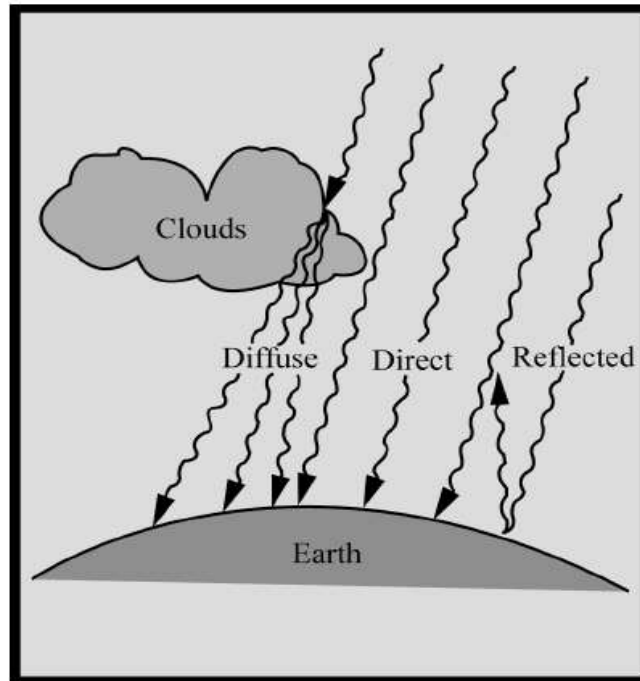

Figure 1 : The radiation of sun through the atmosphere[3]

The intensity of solar radiation outside the atmosphere varies throughout the year as the earth travels through its orbit. The average intensity of solar radiation outside the atmosphere is about  $1353 \text{ W/m}^2$  and is referred to as the solar constant [15]. However, not all of this radiation reaches the surface of the earth. This is because the solar rays that enter the atmosphere are absorbed, scattered and reflected by particle molecules such as air, water, dust, cloud and pollutants before reaching earth's surface. The radiation that reaches the surface directly in the line of the sun without being scattered or reflected is called the beam radiation. The scattered radiation is called the diffuse radiation whereas the radiation reflected from the ground is known as the reflected radiation. The sum of these three components is known as global radiation. The maximum global radiation incident on earth's horizontal surface is approximately  $1000 \text{ W/m}^2$  at noon at sea level.

Another characteristic of the energy based on solar that should be taken to notice is the availability of the sun. Level of the solar insolation (radiation) fluctuates based on time as the path of the sun changes. There will be no sunlight at night and usually the sun only rises from 8am – 5 pm. The peak of the insolation is at noon. The description can be seen through the Figure 2.

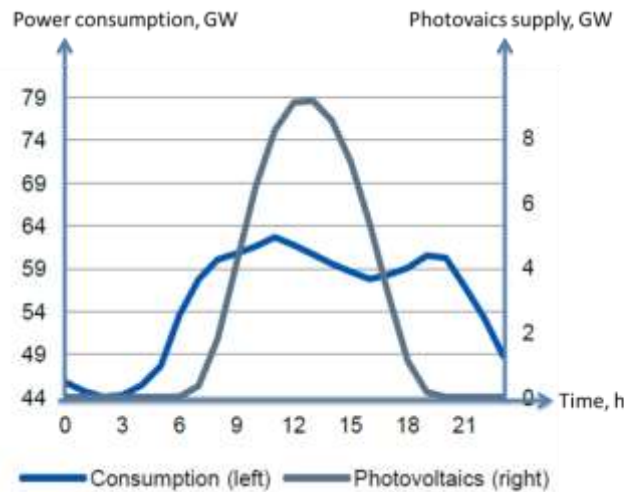

Figure 2 : Fluctuations in consumption and PV electricity over the day in Japan [4]

It can be seen from the graph that the load demand higher at night, but the sunlight availability is limited until dawn. So therefore need for storage to generate the electricity during the absent of sunlight. There are two recommendation to generate the electricity during the absent of sunlight, either by auxiliary power generation or by batteries storage.

### 2.1.2 Issue In PV Electric Generation System

Photovoltaic electric generation system is solely depending on sunlight. There are several issues that should be noticed by researcher when dealing with solar based electric generation. The issues are as follow:

- Availability of the sunlight

The sun only present at the day time. So, precaution should be taken at night time.

- Meteorological conditions

Although during day time, meteorological conditions such as snowing, raining, cloudy season does affecting the electric generated.

- Angle of declination

Angle of declination can be defined as the efficiency of the harness of the sun that is gain by the PV arrays. If the tilt angle between the sun trajectory and the zenith point is reach, the higher the efficiency of electric produce by the system. These are put into consideration as the apparent trajectory of the sun varies daily and seasonal



Figure 3 : Inclination and rotational of Earth that affect the PV electricity generation system[5]

## 2.2 PV Electric Generation System

Solar power systems are independent power generation systems meant to power an individual structure or an entire community. A 2-kW photovoltaic generating system will eliminate about 40 tons of carbon dioxide emissions over its lifetime the equivalent of planting half a hectare of trees[6]. The solar power block diagram in below describes a typical system of solar panels, a controller, energy storage and an inverter for conversion of DC to AC.

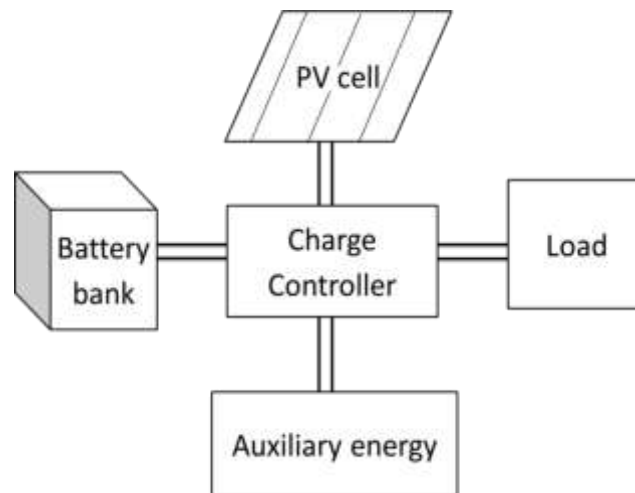

Figure 4 : PV electricity generation component

### 2.2.1 PV Array

A PV arrays consists of semiconductor cells that absorb sunlight and generate electric current. Many cells are combined into a sealed module. Modules are wired together into a PV array. The PV modules which are composed of many solar cells are integrated to form solar array. The hourly energy generated ( $E$ , kWh) from the PV system is calculated using the equation below:

$$E = \eta I_G A$$

where  $A$  is the array area in  $m^2$ ,  $\eta$  is conversion efficiency and  $I_G$  is the hourly insolation ( $kWh/m^2$ )



PV arrays usually related with the efficiency of the converted energy from the sun. PV arrays play an important role as it will collect sunlight and produce electricity. So, table below are the comparison between PV arrays using different materials.

Cell Type	
Monocrystalline Silicone	<ul style="list-style-type: none"> <li>• Uniform pattern</li> <li>• Typically dark in color</li> </ul>
Polycrystalline Silicone	<ul style="list-style-type: none"> <li>• Non-uniform pattern</li> <li>• Typically bluish</li> <li>• Slightly low cost</li> </ul>
Thin film	<ul style="list-style-type: none"> <li>• Deposited in thin layer</li> <li>• High adaptation ability</li> </ul>
Amorphous Silicon	<ul style="list-style-type: none"> <li>• Lack of crystalline properties</li> <li>• Better performance at higher temperatures</li> </ul>
Dye-synthesized Solar cell (DSSC)	<ul style="list-style-type: none"> <li>• Low cost thin film</li> <li>• Efficiency: 5-8%</li> </ul>

Table 1 : Comparison between the type of PV arrays[7]

The efficiency of the PV also different based on the cell type. Below are the typical efficiency based on a few cell type.

Cell Type	Typical efficiency (%)
Monocrystalline Silicone	12-15
Polycrystalline Silicone	11-14
Thin film	7-10
Amorphous Silicon	6-8
Dye-synthesized Solar cell (DSSC)	5-8

Table 2 :Efficiency of difference cell type[7]

### **2.2.2 Inverter/Charge Controller**

The direct current (DC) electricity produced by the PV array is fed through an inverter which converts DC to AC. Most of the demand will be in AC as the alternating current needed by most homes and business appliances.

The main functions of a charge controller are to maintain the battery at the highest level state of charge that is possible and to protect the battery from being overcharged or over discharged. Charge controller also acts as the bridge from PV arrays to other parts of the PV systems. Its other function is to provide load control functions which it will automatically connects or disconnects the electrical load at a specified time.

### **2.2.3 Auxiliary**

An auxiliary energy system is operated at times when PV fails to satisfy the load and when the battery storage is depleted. A typical auxiliary back-up is diesel or wind electric generation system. The main concern of this part is to make the system sustainable. Without considering the sustainability, this will make the system imperfect as the demand is not satisfied.

### **2.2.4 Battery Bank**

Battery storage systems used to comprise a large part of the PV's investment, it is essentially stored for later use. As the PV electric generation technology has an issue with sustainability during at night and other circumstances, the battery will be the source of the electricity. The selection of a proper size of the battery bank for these types of applications requires a complete analysis of the battery's charge and discharge requirements, including load, output and pattern of the solar or alternative energy sources, the operating temperature, and the efficiency of the charger and other

system components. Usually, energy losses occur when charging the battery bank, and the efficiency drops when the battery ages and is not operated correctly.



Figure 5 : Batteries bank[8]

The type of the connection of the battery bank also should be considered as it will affect the total current and voltage produce.

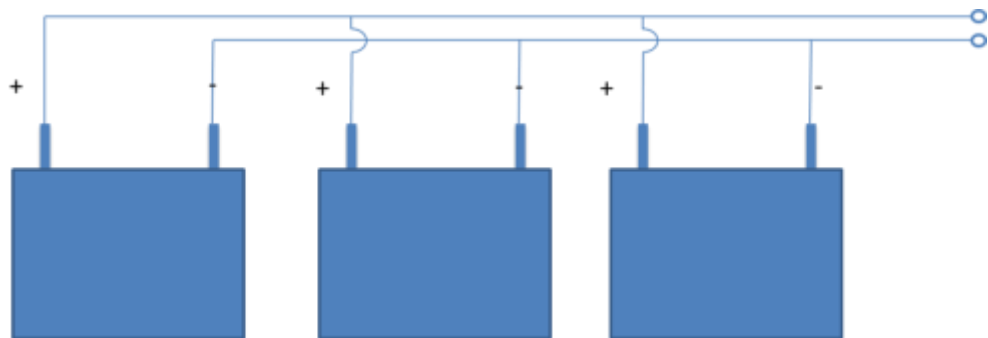

Figure 6 : Parallel connection of the battery bank

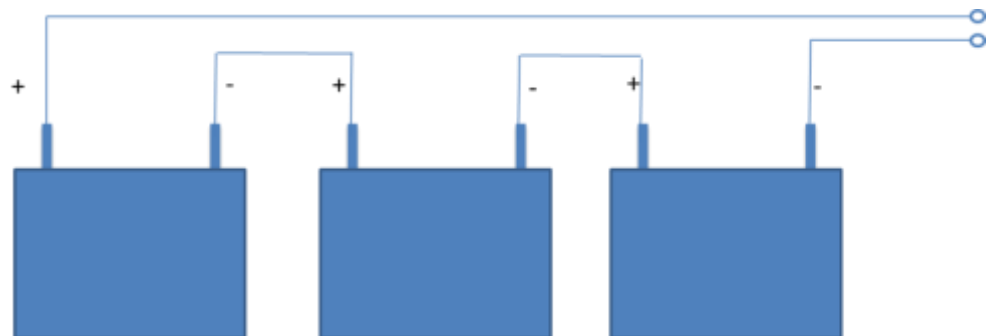

Figure 7: Series connection of the battery bank

### **2.2.5 Load**

The load demand, determines the requirements of power supply from the system. The loads can be DC or AC. The load must be supported by the electric produce by the PV arrays and battery specifications.

## **2.3 Battery Monitoring**

The batteries monitoring is the main concern of this project. Basically, batteries are used for energy storage. Without a proper monitoring of the batteries, the system will be unusable during absent of sunlight.

Monitoring can improve the system reliability by detecting battery problems at an early stage, before they can cause an abrupt system failure. The advantages of making the battery monitoring system are as follow:

- Reducing maintenance time  
Most of the time the maintenance will be monitor by system. So, reducing time to manually check the battery.
- Optimizing battery life  
The monitoring will assist in taking corrective action against any out-of-tolerance condition can prevent premature aging of the battery.
- Reducing test cost  
A permanent installed monitor can log data during scheduled or unscheduled discharges eliminate a substantial amount of servicing cost.
- Safety  
If the monitor identified problem, the system can be programmed to alert the maintenance personal the current condition of the battery.

### 2.3.1 Type of batteries

Currently there are three type of batteries in the current market which is primary cells or non-rechargeable batteries, secondary cells or rechargeable batteries and also batteries by application. Basically, primary cell is a battery that will run out of power when its entire chemical has been used. Secondary cell is a battery that can be rechargeable and battery by application is a battery that is made for a certain purpose. The table below shows example of each type of batteries.

Type	Examples
Primary cells or non-rechargeable batteries	<ul style="list-style-type: none"> <li>• Dry cell</li> <li>• Alkaline battery</li> <li>• Zinc-carbon battery</li> </ul>
Secondary cells or rechargeable batteries	<ul style="list-style-type: none"> <li>• Lithium-ion battery</li> <li>• Fuel cell</li> <li>• Lead-acid battery</li> <li>• Nickel-cadmium battery</li> </ul>
Batteries by application	<ul style="list-style-type: none"> <li>• Button cell - for watch battery</li> <li>• Backup battery - secondary power supply for Aircraft emergency batteries, Burglar alarms, Computers and Telephones</li> <li>• CMOS battery - in mother board to power up the memory and real-time clock</li> <li>• Common battery types for PVEGS</li> </ul>

Table 3: Examples of each type of batteries [8]

### 2.3.2 Common batteries in PVEGS

Solar electricity conversion happens during day time, and is intermittent in nature. So, the roles of the batteries are really important in PVEGS as it will produce an optimum output. Below are three common batteries used in PVEGS.

Types	Descriptions
Lead Acid	<ul style="list-style-type: none"> <li>• These batteries used lead oxides as electrodes. The electrolyte is dilute sulphuric acid. Most of the PVEGS will choice Lead-Acid battery as backup power systems</li> <li>• Industrial type batteries can last as long as 20 years with moderate care. With the usage of typical vehicles, it should last 3-5 years.</li> </ul>
NiCad (Nickel Cadmium)	<ul style="list-style-type: none"> <li>• These alkaline batteries used nickel oxide as positive active material and the negative contains cadmium.</li> <li>• There are few downsides of NiCad batteries such as very expensive and very hazardous. It has a low efficiency in the range of 65-80% and produce non-standard voltage and charging curves that will make it difficult to use with some equipment, such as standard inverters and chargers.</li> </ul>
NiFe (Nickel Iron)	<ul style="list-style-type: none"> <li>• NiFe has a energy storage density of 55 watts per kilogram</li> <li>• The electrolyte is potassium hydroxide while having the anodes of steel wool substrate with active iron material and cathodes of nickel plated steel wool substrate with active nickel material. The batteries are alkaline-type electric and have very long life.</li> <li>• There are a few downsides of NiFe batteries although it has a long life, which are low efficiency, typically 60-65%.the batteries have very high rate of self-discharge and high internal resistance that can make large voltage drops across series cells. NiFe also can reduce the overall efficiency of the solar system as much as 25%</li> </ul>

Table 4 : Common batteries in PVEGS[8]

### 2.3.3 Issues Using Battery

As the battery bank is deeply related to the system, common causes of premature battery system failure should be known.

Issues	Impacts
1. Low temperature	A higher voltage will be required to maintain full charge of the batteries if it is put at low temperature surrounding
2. High temperature	The battery life will be loss if the batteries are put at high temperature surrounding
3. Excessive cycling	The cycling capability of lead calcium depends on the depth of discharged
4. Post seal leakage	If the batteries post seal is leak, it will cause connection problem as the acid is migrate up to the intercell connection area
5. Loose intercell connection	A loose intercell connection is will produce very high resistance connection and disturb the circuit
6. Low float voltage	A Low float voltage will increase the cell resistances as sulphate crystals will be form on plate surfaces
7. Discharge without recharge	The batteries will be damaged and possibly ruined if it is fully discharged or nearly fully discharged.
8. Over discharge	The batteries will undergo permanent damage and recharge problem as the over abnormal expansion of plates happening due to over discharge
9. Electrochemical resistance increase	Electrochemical resistance increase make the batteries to run out of fuel and become incapable of delivering rated capacity. Electrochemical resistance usually happen due to the problem in paste or electrolyte.

Table 5 : Issues regarding batteries and its impacts.[9]

# CHAPTER 3

## METHODOLOGY

### 3.1 Research Methodology

In the beginning of the semester, the titles for the Final Year Project had to be chosen or proposed. After the project title was chosen or approved, preliminary research work and literature review was done on the project title. The next task was to understand more regarding the project and learn from the literature reviews and researches. After understanding about the project, the actual software and hardware application was done. Next step was to simulate the process of the project until the requirement is satisfied. The last step of the procedure is to prepare the project report and presentation

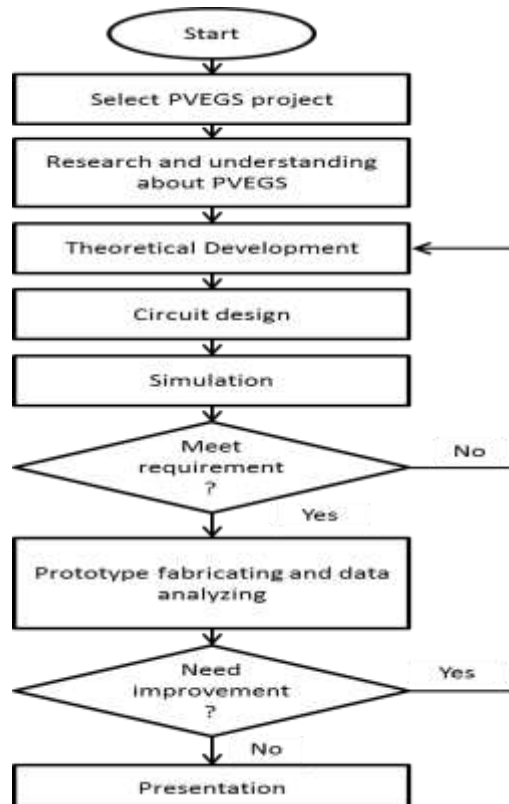

Figure 8: Research Methodology



### 3.2 Project Duration

In order to effectively monitor the progress of this project, a Gantt chart consists of two semester duration had been constructed.

FYP 1														
Activities	Week Number													
	1	2	3	4	5	6	7	8	9	10	11	12	13	14
Topic selection	■	■												
Study on the topic selected		■	■											
Literature review			■	■	■									
Submit the extended proposal (27/6)						■								
Search and buy the component						■	■							
Proposal defense presentation (18/7)							■	■	■					
Developing all the hardware and software system								■	■	■	■	■	■	■
Interim report submission (15/8)													■	■

FYP 2														
Activities	Week number													
	1	2	3	4	5	6	7	8	9	10	11	12	13	14
Testing the system	■	■	■	■	■	■	■	■	■					
Solve the project problem		■	■	■	■	■	■	■	■	■				
Submit the progress report (5/11)								■						
ELECTREX (28/11)											■			
Submit the draft report (10/12)													■	
Submit the final report and technical paper (17/12)														■
Viva session (20/12 – 21/12)														■
Do some improvement and finalize												■	■	■
Submit the final report (7/1)														■

Table 6: Gantt Chart

### **3.3 Tools**

PSpice is software for analog circuit and digital logic simulation program for Microsoft Windows. It is often used by student or for learning purposes. The name is an acronym for Personal computer Simulation Program with Integrated Circuit Emphasis. PSpice is used mainly to design and simulate the circuit connected with the battery. The advantage of using PSpice in this project is it can simulate the circuit and the user can trouble shoot the problem in the circuit without compiling the circuit.

Arduino is the main equipment in this project. It is a microcontroller and a tool for making computers that can detect and control the physical world than desktop computer. It is a physical computing platform based on open source simple microcontroller board, and software development environment for writing to the board. Another function of Arduino is it can be used to develop interactive objects, taking inputs from a variety of switches or sensors, and control the various lights, motors, and other physical outputs.so, in this project, it will perform the battery monitoring and add other significant function to enhance the battery monitoring

## CHAPTER 4

### RESULTS AND DISCUSSION

#### 4.1 Problems regarding battery

The concern with battery monitoring is noted if it is used in large scale industry. The batteries will be puts in arrays and should be maintenance to give a rated output. The challenge will be to know which battery is fault or malfunction. Below are results of simulation of small scale battery fault.

Damage battery	3 batteries (in series) ,V	6 batteries (series and parrallel) ,V	9 batteries ( series and parallel) ,V
0	4.56	4.55	4.57
1	0	4.53	4.55
2	0	4.54	4.53

Table 7: Result of damage batteries in random

As the experiment is finished, the problem is seen clearly. The fault batteries cannot be detected just using the total voltages/output of the batteries. The fault batteries do not affect much the value of total voltage produce. So, a monitoring system should be made.

#### 4.2 Proposed Design

Based on the simulation of small scale batteries fault, we can conclude that each battery should be monitored solely so that the fault can be detected.

### 4.2.1 Design Methodology

This is the monitoring mechanism that is set up based on the needs for the monitoring. of the batteries.

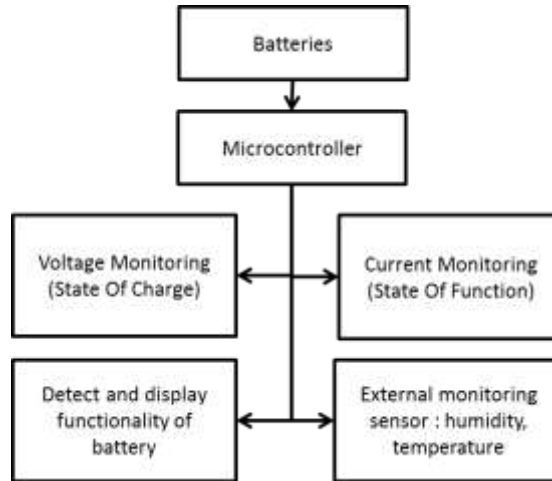

Figure 9 : Battery Performance Monitoring in PVEGS mechanism

The Battery Performance Monitoring in PV-EGS basically using microcontroller as the main component. It will be used to monitor the battery bank. The characteristic that will be monitored by the system is State Of Health, State of charge, State of function, and the functionality of the battery bank.

An additional value also has been added to the Battery Performance Monitoring system such as external monitoring system will detect the humidity and temperature surrounding the batteries bank.

#### 4.2.2 Battery Performance Monitoring in PVEGS

To make Battery Performance Monitoring in PVEGS, 12 Volts rechargeable battery will be the reference. Data is analysed by using Programmable Integrated Circuit Arduino Uno. The PIC will show the value using the 16x2 Liquid Crystal Display.

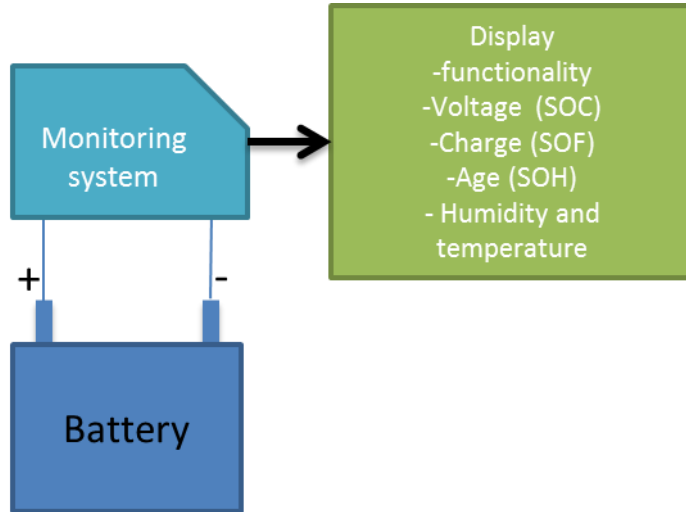

Figure 10 : Proposed batteries performance monitoring system

Below are the strategies to monitor the batteries performance:

Parameter	Description
Functionality	Detect the condition of the battery using Programmable Integrated Circuit Arduino Uno
Voltages	Monitor the voltage of the battery using voltage divider
Charges	Measure the current of the battery using current sensor
External monitoring sensor	Determine humidity, temperature, light intensity surrounding the batteries using DHT 11

Table 8: Parameter that will be monitored by the system

### 4.3 Project hardware

In order to make the prototype, a set of components must be chosen to be the inputs and output to monitor the batteries performances. Below are the components and strategies that are used to make the prototype.

#### 4.3.1 Voltage sensor

The prototype is using PIC Arduino Uno and it has the capability to measure the voltage in the range of 5V. The battery used in this project is 12V and the batteries will damage the PIC if it is directly connected. So, voltage divider is used to make a new reference voltage in the range of 5V. The value of the resistors also must be calculated to get current below 200mA as current above 200mA will damage the PIC.

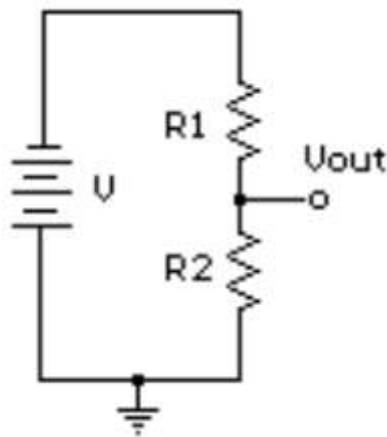

Figure 11 : Voltage divider

	Value
Battery voltage (volts)	15
Current (amperes)	0.0001
R1(ohms)	10000
R2(ohms)	50000
V out (volts)	5

Table 9 : Values of components in voltage divider

### 4.3.2 Current sensor

The current sensor is used to measure the current of the batteries. The current measured is used to know the state of health which determines the estimated time before the batteries is run out. The current sensor used in this project is BB ACS 756 current sensor.



Figure 12 : BB ACS 756 current sensor

### 4.3.3 Temperature and humidity sensor

The batteries performance is affected by the surrounding especially with water and heat. So, temperature and humidity sensor is used to detect the surrounding temperature and humidity. The Temperature & Humidity Sensor used in this project is DHT11 Temperature & Humidity Sensor.



Figure 13 : DHT11 Temperature & Humidity Sensor



#### 4.3.4 Liquid Crystal Display

The Arduino Uno has the features to show the measurements and results on Personal Computer (PC) or on the external display. As this project is developing a stand-alone system for batteries performance monitoring in PV-EGS, a 16x2 LCD is chosen as it has minimum requirement to display the data needed.



Figure 14 : 16x2 Liquid Crystal Display

#### 4.3.5 Battery

Batteries are the main component in this project. The batteries that are used must be rechargeable and can be used with real PV-EGS. So, NP7-12 Sealed Rechargeable Battery is used. Below is battery figure and specification.



Figure 15 : NP7-12 Sealed Rechargeable Battery

Battery type	Valve-regulated lead-acid Maintenance free lead-acid battery
Voltage	12V
Dimensions (L x W x H)	151 x 65 x 94mm
Weight	2.15kg
Nominal capacity	7Ah/20 hours

Table 10 : Battery Specifications

### 4.3.6 Battery monitoring prototype

The circuit is assembling using the PIC Arduino Uno as the main component. The other hardware is connected to monitor the battery parameter except LCD 16x2 will show the results. The figure below show the schematic design and prototype of battery performance monitoring in PVEGS.

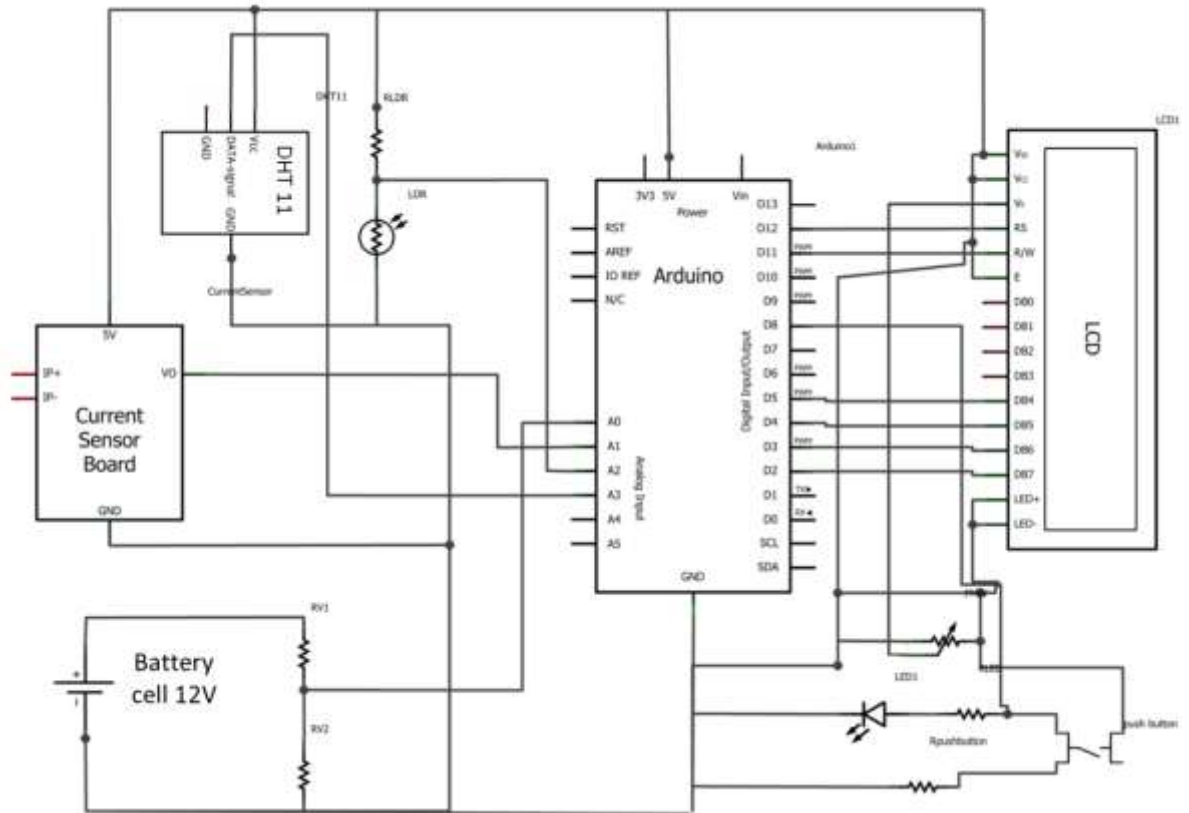

Figure 16 : Circuit Diagram of Battery Monitoring

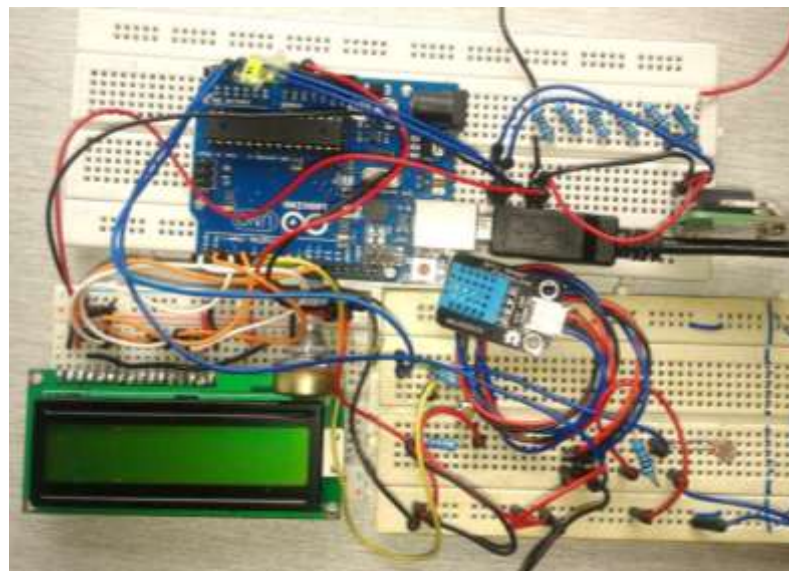

Figure 17 : Battery Monitoring Prototype

#### 4.4 Results

To use battery monitoring prototype, the battery must be connected with the prototype. The prototype will automatically display the current Voltage of the battery. When a push button is pressed, the LCD will display Current of the battery. If the push button is keep on pressed, the LCD will show the temperature surrounding the batteries in Celsius and Fahrenheit. Next, the LCD will show humidity and light intensity in percentage surrounding the battery when the push button is pressed.

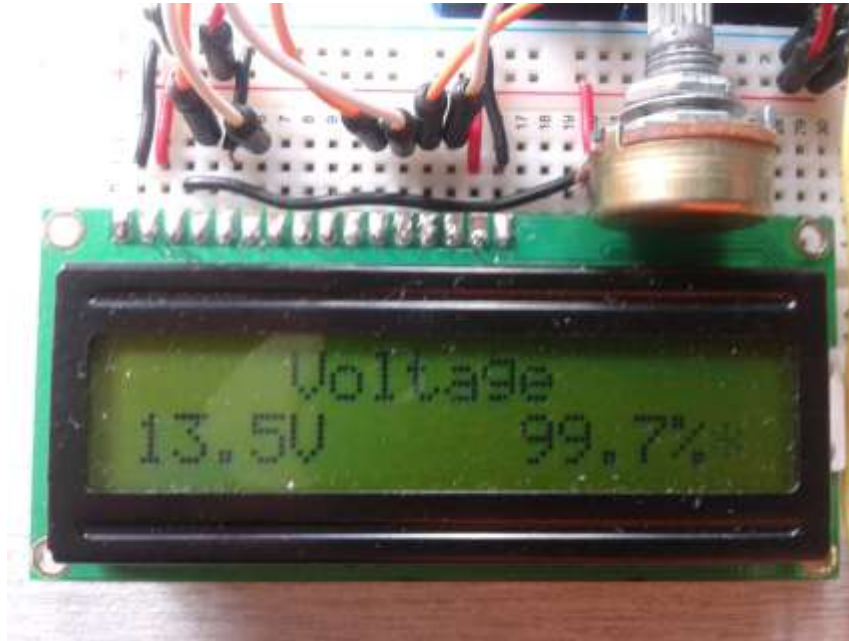

Figure 18 : Display Voltage of the Battery



Figure 19 : Display Current of the Battery

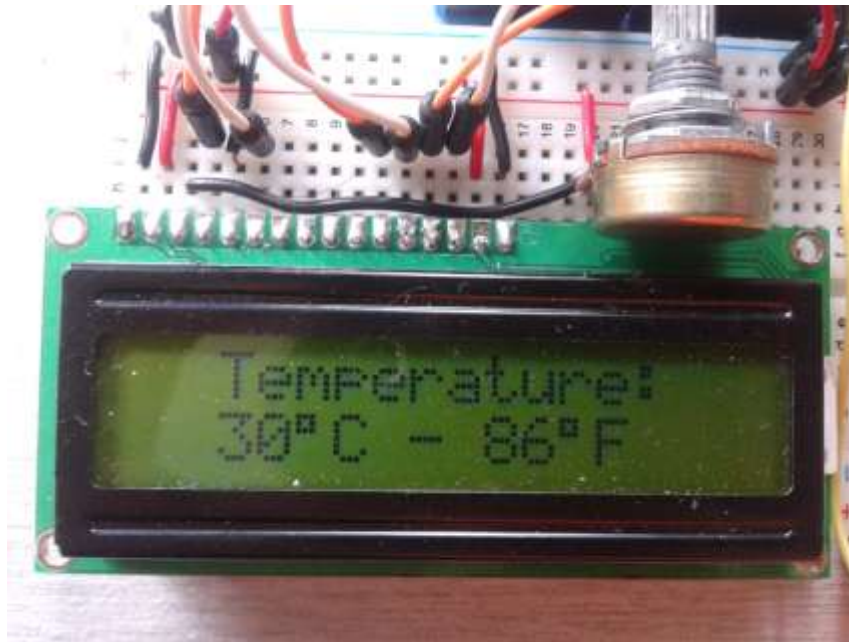

Figure 20 : Display Temperature Surrounding the Battery



Figure 21 : Display Humidity Surrounding the Battery



Figure 22 : Display Light Intensity Surrounding the Battery

## **CHAPTER 5**

### **CONCLUSION AND RECOMENDATION**

#### **5.1 Conclusion**

This project introduces a batteries performance monitoring system in PVEGS. This system enables us to predict the performance of the entire PVEGS and as a monitored mechanism in battery monitoring. The objective is achieved as all the components of the battery are taken into account.

#### **5.2 Recommendation**

For future work, the project can be continued by integrating the photovoltaic electric generation system with national grids. The current project conducted in standalone system. So, if the integrating the photovoltaic electric generation system with national grids if continued, the photovoltaic electric generation system can be used by all house and company in town.

The another recommendation for improvement is to extend the current monitoring system to monitor different sizing of PV arrays and batteries bank by using wireless monitoringsystem.

## REFERENCES

- [1] Michael Viaud, Sven Teske, "Solar Generation," European Photovoltaic Industry Association (EPIA) and Greenpeace International, 2004.
- [2] Science Direct, Renewable Energy 28 (2003)[Online]. Available: <http://www.sciencedirect.com/science/article/pii/S0038092X06001836>
- [3] The German Energy Society, *Planning and Installing Photovoltaic Systems: A Guide for Installers, Architects and Engineers*. London, UK: James and James Science Publishers, 2005.
- [4] Yokogawa Technical Library (Test and Measurement) [Online]. Available: <http://tmi.yokogawa.com/technical-library/application-notes/measuring-power-bought-and-sold-via-power-conditioners/>
- [5] M. Pidwirny. (2006, September) Earth-Sun Geometry. [Online]. Available: <http://www.physicalgeography.net/fundamentals/6h.html>
- [6] Solar Power (Technology and Economics) [Online]. Available: [http://www.mpoweruk.com/solar\\_power.htm](http://www.mpoweruk.com/solar_power.htm)
- [7] S. Liu and R. A. Dougal, "Dynamic Multiphysics Model for Solar Array," *IEEE Trans. on Energy Conversion*, vol. 17, no. 2, pp. 285-294, June 2002.
- [8] IEEE Guide for Array and Battery Sizing in Stand-Alone Photovoltaic (PV) Systems, 2007.
- [9] Battery Maintenance (Reliable Battery Systems Won't Happen Without Proactive Testing And Maintenance) [Online]. Available: <http://www.powerengineer.com/Reliable%20Battery%20Systems.htm>