

**GENERATOR PROTECTION STUDIES AT KAPAR ENERGY VENTURES POWER
STATION (KEV)**

By

MASHITAH BINTI SULAIMAN

FINAL PROJECT REPORT

Submitted to the Electrical & Electronics Engineering Programme
in Partial Fulfillment of the Requirements
for the Degree
Bachelor of Engineering (Hons)
(Electrical & Electronics Engineering)

Universiti Teknologi Petronas
Bandar Seri Iskandar
31750 Tronoh
Perak Darul Ridzuan

© Copyright 2009
by
Mashitah binti Sulaiman, 2009

CERTIFICATION OF APPROVAL

**GENERATOR PROTECTION STUDIES AT KAPAR ENERGY
VENTURES POWER STATION (KEV)**

by

Mashitah binti Sulaiman

A project dissertation submitted to the
Electric and Electronics Engineering Programme
Universiti Teknologi PETRONAS
in partial fulfilment of the requirement for the
BACHELOR OF ENGINEERING (Hons)
(ELECTRIC AND ELECTRONICS ENGINEERING)

Approved by,

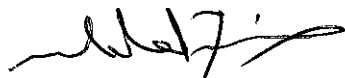

(Ir. Mohd Faris bin Abdullah)

UNIVERSITI TEKNOLOGI PETRONAS

TRONOH, PERAK

DEC 2009

CERTIFICATION OF ORIGINALITY

This is to certify that I am responsible for the work submitted in this project, that the original work is my own except as specified in the references and acknowledgements, and that the original work contained herein have not been undertaken or done by unspecified sources or persons.

Mashitah

Mashitah binti Sulaiman

ABSTRACT

The main purpose of electric device is to isolate the faulted component from the healthy part as fast as possible in order to prevent further damage and endangering human life. The objectives of these studies are to study the overall generator and generator transformer protection at Kapar Energy Ventures and propose recommendation to improve the protection setting and coordination (if required). Generator protection is very important to safe guard the generator at Kapar Energy Ventures power station. Nevertheless, the auxiliary system to the generator plays an equally vital role to ensure that the generator continue to work as intended. There were times that generator and its auxiliary equipment had tripped due to miscoordinated protection system or wrong settings. A protection system must satisfy the following requirements

- Selective – disconnect the equipment is restricted to the minimum necessary to isolate fault.
- Sensitivity – sensitive enough to operate under minimum fault condition.
- Stable – stable and remain inoperative under certain specific condition .
- Fast – fast operation in order to clear the fault from the system and to minimize damage to the affected component
- Reliable – the protective equipment should not fail to operate in the events of faults in the protected zone. It may be necessary to provide backup protection to cover the failure the remaining protection

ACKNOWLEDGEMENTS

The successful completion of this project has been made possible through the help and support of many individuals. First and foremost I would like to extend deepest appreciation to my project supervisor, Ir. Mohd Faris bin Abdullah, who has graciously accepted me as his Final Year Project Student, without which this project would not be possible in the first place. His attention and assistance have encouraged me to put extra effort in finishing this project. Special thanks to Mr. Amirul, director from Antawara Sdn. Bhd for his tremendous help throughout this project whose endlessly support and guides me in finishing this project.

My thanks and appreciation also goes to all technicians, especially Puan Hawa who always be there to help me during project execution. Last but not least to my parent for motivational support that I appreciate the most. The association I have made during this project will truly be memorable for years to come.

TABLE OF CONTENTS

CERTIFICATION OF APPROVAL.	i
CERTIFICATION OF ORIGINALITY	ii
ABSTRACT	iii
ACKNOWLEDGMENT.	iv
TABLE OF CONTENTS	v
LIST OF FIGURES	vii
LIST OF TABLES	viii
CHAPTER 1:	INTRODUCTION	1
	1.1 Background of Study	1
	1.2 Problem Statement	3
	1.3 Objectives	5
	1.4 Scope of Study	6
CHAPTER 2:	LITERATURE REVIEW	7
	2.1 Generator	7
	2.2 Generator Fault	9
	2.3 Generator Protection	11
CHAPTER 3:	METHODOLOGY	29
	3.1 Procedure Identification.	29
	3.2 Calculation	30

CHAPTER 4:	RESULTS AND DISCUSSION	. . .	32
4.1	Nominal Current.	. . .	32
4.2	Differential Relay	. . .	34
4.3	Stator Earth Fault	. . .	51
4.4	Low Forward/Reverse Power Relay	.	53
4.5	Voltage Dependant Over current Relay		53
4.6	Negative Phase Sequence Relay	.	55
4.7	Field Failure Relay	. . .	57
4.8	Overvoltage Relay	. . .	58
CHAPTER 5:	CONCLUSION AND RECOMMENDATION		59
REFERENCES	61
APPENDIXES	63

LIST OF FIGURES

Figure 1: Current Transformer	12
Figure 2: CT Knee Point Voltage	13
Figure 3: Generator Differential Connection With Over Current Relay under Through Fault Condition	16
Figure 4: Generator Differential Connection With Over Current Relay under Internal Fault Condition	16
Figure 5: Solidly Grounded Generator	18
Figure 6: Neutral Impedance Grounding	19
Figure 7: Generator with Distribution Transformer Grounding.	20
Figure 8: DC Detector	22
Figure 9: AC Detector	23
Figure 10: Methodology of work	29
Figure 11: Generator Differential Operation Characteristic	35
Figure 12: Generator Transformer Differential Relay.	43
Figure 13: Disposition of Winding on Distribution Transformer	45
Figure 14: Interposing CTs Connection	46
Figure 15: Bias Differential Characteristic	49
Figure 16: Voltage Restrain Mode Definite Time Characteristic	54
Figure 17: Negative Phase Sequence Characteristic	56
Figure 18: Field Failure Protection Characteristic (mho characteristic)	57

LIST OF TABLES

Table 1: Protection CT Accuracy Class	14
Table 2: Interposing Current Transformer that Available for Current Ratio and Phase Angle Matching with Line CTs Used with Transformer Differential Relay Type MCB	44
Table 3: Details of the Number of Turns on Each of the Transformers Noted in Table 2	44

CHAPTER 1

INTRODUCTION

1.1 BACKGROUND OF STUDY

Power generation is a matter of conversion of energies from one state to another. The chemical energy in fossil fuels (oil, gas & coal) is converted to heat energy in the furnace. The heat from the burning fuel then causes the water in the boiler to change to steam. The energy in the steam is used to drive the turbine thereby converting the heat energy in steam into kinetic energy. The turbine shaft is coupled to the generator rotor and as the rotor turns, the kinetic energy in the rotating shaft is converted into electrical energy in the stator coils by electromagnetic induction [1].

The generator typically consists of the rotor (which carries the field winding), the stator (which carries the stator winding wound for three-phase) and includes the cooling, lubrication and sealing systems as well as the mechanical structure. The rotor windings are supplied with excitation current (DC) from the exciter. This excitation current causes the rotor coils to act like a huge magnet. As the rotor rotates the magnetic field cuts the coils on the stator winding and thus produces electricity in the stator coils.

This electricity is the output of the generator, which is led out from the generator terminals via the GCB (Generator Circuit Breaker) to the Generator Transformer, where it is stepped-up to 275kV and connected to the 275 kV bus bars

in the switchyard. Some of the power is routed to Unit Transformers A & B which step-down the voltage from 22kV to 11kV before supplying the unit auxiliaries.

The current that flows through the windings of a large generator can reach very high values. The flow of these current causes heating because of the $I^2 R$ losses. This heating is quite substantial and will damage the winding insulation if it is not kept under control. The temperature of the rotor windings too must be kept low to prevent deterioration of insulation. In addition there is 'windage' losses caused by friction between the hydrogen gas and the rotor as it rotates.

Protective system is parts of an electrical power system that covers the minimization of service interruption and limitation of equipment damage. The system shall function to remove the faulty elements from the power system with a speed that commensurate with overall power system requirements [2]. A good protection system includes protection against fault (short circuit, earth fault, etc.), proper coordination between protection devices and appropriate grading margins.

Protective device are also place on the electrical side of the turbine generator unit to provide purely mechanical protection. Low or high frequency protection is one of the examples that will protect the turbine blade. In some cases, the basic disturbance is due to some event or condition on the electric system that can readily be detected by monitoring electrical quantities which can be used to remove the machine before any mechanical damage occur. The studies are focused on the protection system coordination at power plant that involves short circuit analysis, grading margins study and protection devices characteristic.

1.2 PROBLEM STATEMENT

1.2.1 Problem Definition

Generator protection is very important to safe guard the generator at Kapar Energy Ventures power station. Nevertheless, the auxiliary system to the generator plays an equally vital role to ensure that the generator continue to work as intended. There were times that generator and its auxiliary equipment had tripped due to miscoordinated protection system or wrong settings.

Generator Protection is used to protect the machine from abnormal operating conditions, which arise from any or all of the following reasons [1]:

- Internal generator failure
- Auxiliary equipment failure
- Operator error
- Abnormal system conditions

Since the protective relays and associated devices themselves could fail at times, a back-up protection is provided for those faults that could cause severe generator damage. The main purpose of the electric protective devise is to isolate the faulted component from the healthy part as fast as possible. This is due to prevent the further damage and mainly to protect human life [3].

1.2.2 Significant of the Project

The study is to find all the possible failure that occur in handling generator and find the protection scheme needed to isolate the fault component. Thus, we need to study the protection coordination in order to isolate the fault component without interrupting the whole system. Due to that, we need to understand the stage of the fault and the point where we need to stop the current flow by switch off the circuit breaker. Besides, we also need to know the types of generator protection since there are many different types of faults that synchronous generators may experience and therefore, many types of protection.

We need to analyze the protection device and finding it setting such as the current transformer ratio, the pickup current, the bias current and etc. After we analyze the protection device, we also can find the saturation point of the protection device. The saturation point is the point where the current transformer will start to have problem or damage.

The protective system always measures certain system quantities such as voltage and current. The system will compare the quantities or some combination of these quantities against the threshold setting that were already set by the protection engineer. All generators will not have the same level of protection.

1.3 OBJECTIVE

The objectives of the project are:

- 1.3.1** To study all the types of fault and failure that occurs in the generator during generating process and the types of generator protection.
- 1.3.2** To study the generator protection concept and analyze the setting of the equipment
- 1.3.3** To calculate some of the setting of the protection device like current transformer and compare it with the actual setting and find the reason of the setting.
- 1.3.4** To conduct short circuit studies and find the proper protection coordinate.
- 1.3.5** To studies the overall generator protection at Kapar Energy Ventures and proposes recommendation to improve the protection coordination (if required)

1.4 SCOPE OF STUDY

1.4.1 The Relevancy of the Project

1. Learn all the fault and failure that occur in the generator system.
 - The fault current value is very important in order to coordinate the fault setting in the system laboratory test.

2. Learn and understand the protection used in generator.
 - The operation characteristic and the setting of the protection device must be carefully coordinated in order to achieve selectivity.
 - The aim is basically to switch off only the selected component and to leave the rest of the power system in service in order to minimize supply interruption and assure stability.
 - The protection coordination is important in order to prevent the further damage to the system and danger to the human life.

3. Calculate the setting for the protection device
 - Calculation will show the setting of the protection device. With this calculation value, we compare it with the actual setting and understand the concept of the selected value of the setting.

The project process includes studies on protection principle, the single line diagram for phase three in Kapar Energy Venture (KEV), the protection device such as the characteristic curve, operation and the available rating and also types of generators protection. Short circuit analysis also being included in the study to obtain the highest short circuit current that may occurred in the network. Earth fault study also been considered in the study.

CHAPTER 2

LITERATURE REVIEW

2.1 GENERATORS

Two generators (each rated for 525MW at 0.85 PF and 22kV) are installed under Phase 3 of Sultan Salahuddin Abdul Aziz Power Station. Each generator consists of a two-pole rotor, which rotates within a stator. The stator consists of the conductors wound round a stator core and held in place by the stator frame. Power is generated in the stator windings when the rotor field cuts the stator conductors as it rotates within the stator. This power is led from the generator output terminals to the GCB (generator circuit breaker) and from the GCB to the generator transformer via Isolated Phase Busbars (IPB).

The stator frame is of twin-dome construction. The generator casing and the end shields at either end are of welded, gas-tight construction, and support the stationary armature winding and core as well as the gas coolers. The rotor is supported within this frame on bearings and the shaft is provided with seals at either end to prevent the escape of gas into the atmosphere.

The principal cooling medium is hydrogen gas, which is contained within the frame and circulated by fans mounted at each end of the rotor. A separate liquid cooling system is provided for the armature (stator) windings. The excitation

is provided by separate auxiliary equipment. The generator is designed for continuous operation and can withstand most abnormal operational conditions such as sudden load and voltage swings or 3-phase short circuits (within prescribed limits).

The functions of generator and generator transformer system are [1]:

- To generate electric power of 22kV using the kinetic energy of steam turbine
- To transmit the power to the 275kV switchyard and also to transmit some power to the unit auxiliary.
- To maintain the steady frequency and operating voltage using the excitation system.
- To isolate the generator from the electrical grid system when there are emergency case or abnormal situations.

2.2 GENERATOR FAULT

2.2.1 Stator Fault

Stator fault occur from insulation breakdown that cause an arc to develop either from phase to phase or from phase conductor to the grounded magnetic steel laminations of the stator. Insulation breakdown may be due to overvoltage, overheating or mechanical damage of the winding insulation due to fault [6].

Overvoltage may occur because of lightning or switching surge. Switching surge usually protected by surge protective devices. Overheating may occur because of unbalance loading or loss of cooling. This will cause insulation deterioration over a period of time.

2.2.1.1 Phase Fault

Phase fault are rarely occur in generator but the fault must be protected. Phase fault can happen in winding end turns. All the 3 phase winding are close or in slot when there are two coils in the same slot. Phase fault usually change to ground fault.

2.2.1.2 Ground Fault

Most of the generator stator winding fault is phase to ground fault. These are because the winding are always in close contact with steel slot at the ground potential [6].

2.2.2 Rotor Fault

Cause by several mechanical and thermal stressed, forced by a variable load cycle.

2.2.2.1 Ground Fault

Field system is normally not connected to the ground. A single ground fault will not cause any fault current but the second ground fault will cause a large of current that may cause extensive damage to the field conductor and rotor steel.

The second earth fault also would short circuit part of the field winding that produces symmetrical field system and unbalanced forces on the rotor [7].

2.2.2.2 Loss of Excitation

It is caused by an open circuit in the main field winding or failure in the excitation system. This will result in loss of synchronism.

Loss of excitation occurs when the generator speed is slightly increased without changing the power input to the machine. The machine will behave as an induction generator and drawing its excitation current from the system. The magnitude is equal to full load rating of the machine. This will cause overheating of the stator winding. Besides, the rotor losses will increase due to the current induced in the rotor body and damper windings.

2.3 GENERATOR PROTECTION

2.3.1 Purpose and Principle

The main purpose of an electric protective device is to isolate the faulted component from the other parts as fast as possible. The equipment will be protected from further damage and more importantly from endangering human life. [3]

2.3.2 Basic Requirements of Distribution Protection

A protection system must satisfy the following requirements: - [3]

- a) Selective - Disconnection of equipment is restricted to the minimum necessary to isolate the fault.
- b) Sensitive - Sensitive enough to operate under minimum fault condition.
- c) Stable - Stable and remain inoperative under certain specified conditions such as transmission system disturbance, through faults, transients, etc.
- d) Fast - Fast operation in order to clear the fault from the system thus to minimize damage to the affected components.
- e) Reliable - The protective equipment should not fail to operate in the events of faults in the protected zone. It may be necessary to provide backup protection to cover the failure of the main protection.

2.3.3 Generator protection

2.3.3.1 Current transformer

A current transformer as shown in figure 1 comprises of two windings. The primary winding is connected in series with the main circuit. In most cases, the primary winding is part of the main circuit. The secondary winding have several turns of wire wrap around the iron core.

The ampere-turns relationship: $N_p I_p = N_s I_s$.

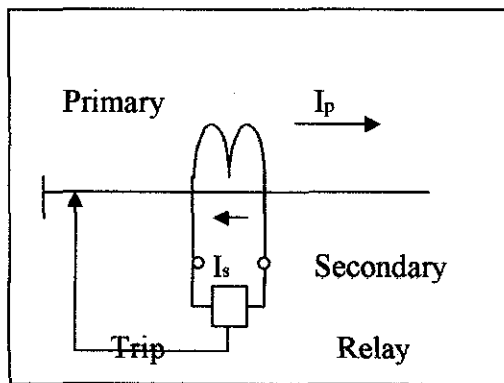

Figure 1: Current transformer

N_p and N_s are the number of primary and secondary turn. The idea is used to provide large number of turns on the secondary to obtain small quantity of current that replicates the primary currents. Current transformer ratio is define as N_p/N_s (example 1500/5 A)

2.3.3.2 Current transformer error and saturation.

There are two important error associated with any current transformer which are ratio and phase error. Ratio error is defined as the different between I_p and I_s which the resistive component of the exciting current is. Phase angle error is due to the quadrature component of exiting current.

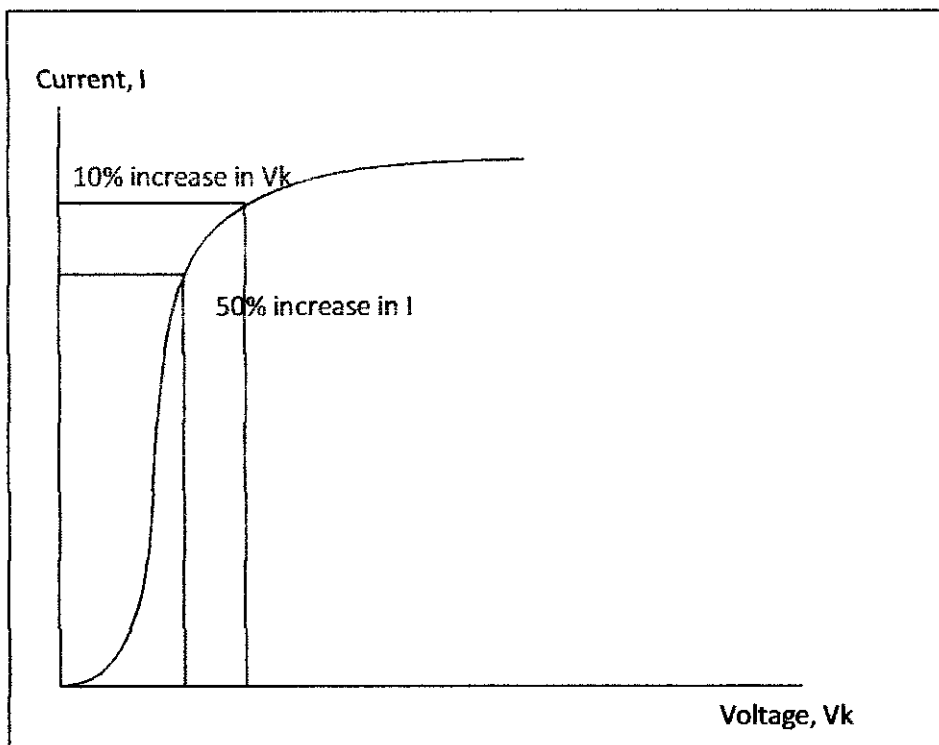

Figure 2: CT knee point voltage

Another important characteristic of a current transformer is saturation. Saturation occurs when a small increase in voltage will cause a large increase in exciting current as illustrated in figure 2. V_k is knee point voltage. 10% increase in voltage will cause 50% increase in exciting current.

Load connected on the secondary of a CT is normally termed as burden in VA. A rated burden assigned to a current transformer is the maximum load at which the CT performs within specified accuracy [3].

When the current transformer is specified, ratio, burden, error and saturation factor are given. For example, 20000/5, 20VA, 5P10. The burden is 20VA and the accuracy class is 5P (see table 1) and saturation factor of /10. saturation factor is linear range of the current transformer [3].

Table 1: Protection CT Accuracy Class

Accuracy Class	Current Error at Rated primary current (%)	Phase error at rated primary current (minimized)
5P	± 1	± 60
10P	± 3	± 60

2.3.3.3 Relays

Relays are usually installed with current. It is used to limit the current. When the current exceed the setting current value, the relay will operate at the time depends on the relay setting. Under fault condition, the relay must operate and disconnect the circuit in time before exceeding the short circuit rating of the protected equipment. Relay must not operate when the circuit is carrying maximum load continuously. Besides, relay also must not operate when the equipment or circuit is allowed to over load in the limited time. For an example, over load 20% less the half an hour.

2.3.3.3.1 Relay construction

- Operating coil = coil is energized by the current from the CT and it will cause movement in the rotor
- Rotor = carries a moving contact. The helical spring attached to the aluminum disc will ensure that no movement occurs below the setting current [3].
- Damping magnet = control the speed of the rotor. Operate on the disc as an eddy current brake.
- Starting current or pickup current = the minimum current to start the relay
- Closing current = amount of current stop the relay.
- Resetting current = value of current to cause the rotor to return to its restrain time.
- Resetting time = time required to reach the restrain position after the current reduces to the resetting value.
- Overshoot time = the time that the rotor move forward after the removal of the current.
- Burden = the load in VA imposed by the relay.

2.3.3.4 Differential Relay

Used for phase fault protection. Differential principle is when the current flowing into one end of the feeder is compared with that flowing out of the other end of the feeder. In differential protection scheme, the matching of the two end current transformer is important to ensure stability on heavy through fault. It is also important to check that the sensitivity of the protection is not affected by the magnetizing current of the current transformer.

Under normal condition or through fault condition, the currents at two ends feeder should be identical and the relay should not operate. See figure 3:

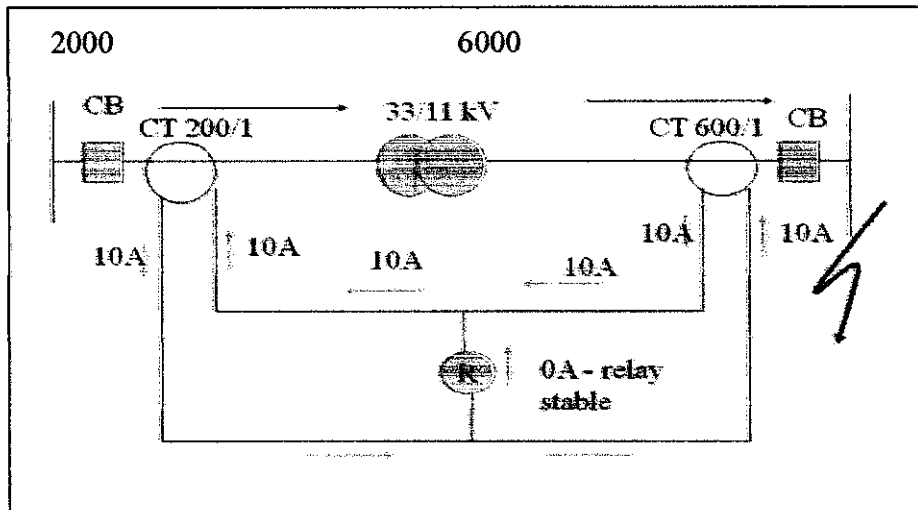

Figure 3: Generator Differential Connection With Over Current Relay under Through Fault Condition [9].

When an internal fault occurs, the current at the two ends feeder is now different. There will be current flow into the relay and the relay will operate. See figure 4:

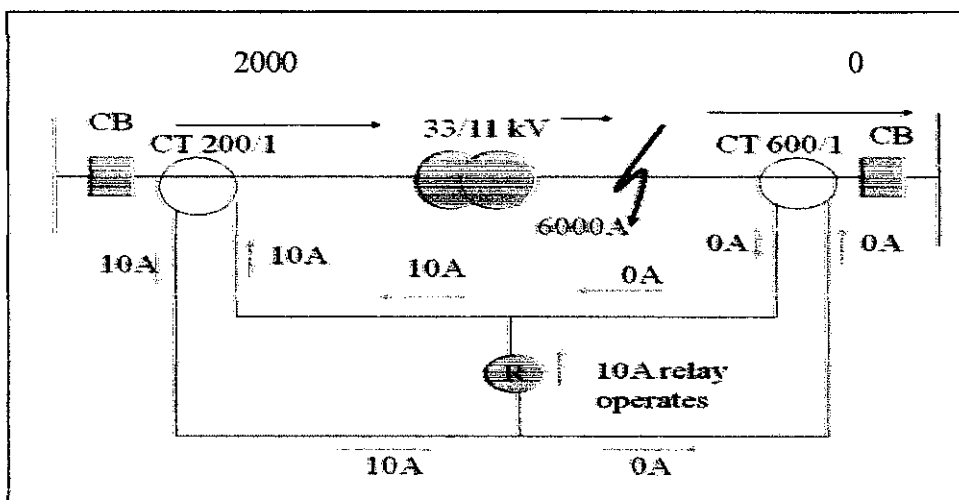

Figure 4: Generator Differential Connection with Over Current Relay under Internal Fault Condition [9].

For short circuit in stator winding, standard practice is to use differential protection on generator rated 1000KVA or higher and on motors 1500hp or larger.

Current transformer or circuit breakers are usually in close proximity with each other. This is done to minimize the burden and error caused by long cable runs. The types and ratio of the current transformer can be the same based on the characteristic. Current transformers used for the generator differential are almost invariably located in the busses and leads are close. This is done to limit the zone of protection so a fault in the generator is immediately identifiable.

Current transformer always reproduces the primary current accurately but under steady state load conditions, there are differences in secondary current due to:

- Variations in manufacturing tolerances.
- Difference in secondary loading (unequal burdens of meter and instruments)
- Transient response of two current transformers is not the same in presence of DC offset during short circuit condition [7].

Over current relay must be set above the maximum error current flowing during fault but must be set under the minimum fault current.

2.3.3.5 Percentage differential relay

The percentage differential relay are used to overcome the fault of the idealized circuit. Electromechanical units have restrained as well as operate winding. Current in the restrain coil produces contact opening torque. Current in the operating coil produces contact closing torque. Relay contact will close when the operating current exceeds the restrain value by a given percentage. The percentage is

referred to as slope of the relay. This design provides an automatic increase in the operating coil current necessary to tripping as fault current and the resulting CT error increase [10].

2.3.3.6 Ground Fault protection

Method of generator grounding will affect the extent of protection provide by the differential relay. When the natural is solidly grounded, the phase current for the phase to ground fault will operate the any differential relay.

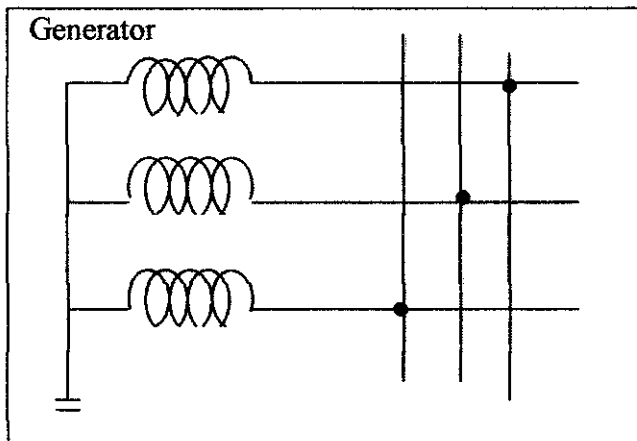

Figure 5: Solidly Grounded Generator

If the generator has neutral impedance, the fault current will be lesser. This will cause the difficulties for the differential relay to detect the ground fault current. Over current protection provided between neutral point and the ground sees all the ground current and can be set without regard to the load current. Increase in grounding impedance will decrease the fault current of phase to ground fault and the damage done by this fault. See figure 6:

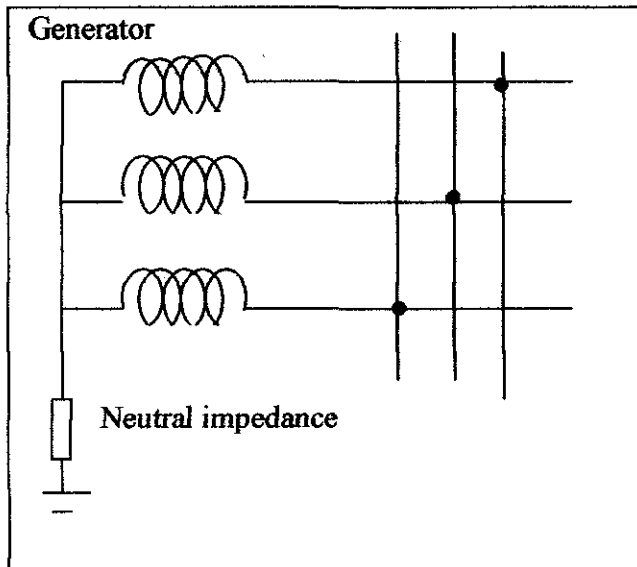

Figure 6: Neutral Impedance Grounding

Large generators used the generator and its generator transformer as a single unit example, failure in the boiler, turbine, generator, generator transformer or any of the associated auxiliary busses result in tripping the entire unit connected system.

Generator is grounded through some resistance to limit the fault current but still provide enough current or voltage to operate relays. There are many methods uses for generator grounding.

- a. Ground the machine neutral directly (high resistance grounding)
- b. Neutral grounded directly through an inductor.
- c. Distribution transformer grounding (using resistance).
- d. Distribution transformer winding (using inductance).
- e. Adding fault resistance to the generators that has no neutral ground.
- f. Zig-zag transformer connection.

Most popular arrangement uses a distribution transformer and resistance. See figure 7:

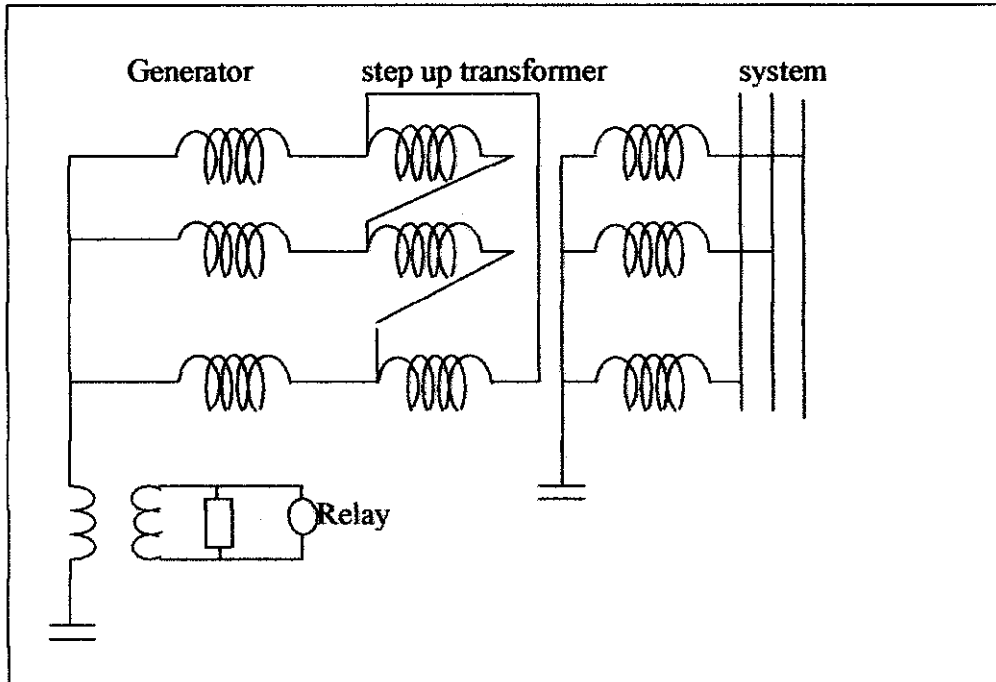

Figure 7: Generator with Distribution Transformer Grounding

Primary voltage rating of the distribution transformer must be equal to or greater than the line to neutral voltage rating of the generator. Voltage transformer should have sufficient over voltage capability so that it does not saturate at 105% of rated voltage.

2.3.3.7 Rotor earth fault protection.

Field circuits of modern generators are operated underground [7]. A single ground fault (first rotor earth fault) on the field of synchronize machine would not produces any immediate damaging effect. However, the existence ground fault will stresses other portion of the field winding. Alarm is issued when the first ground fault occur to start the shut down procedure at first opportunities orderly.

The second ground fault will cause severe unbalance, rotor iron heating, and vibration. There are two methods for detection of rotor earth fault:

1. dc detector
2. ac detector

The field winding earth fault relay is usually instantaneous in operation and connected with alarm when there is no immediate danger to set. In both scheme, earth return path is through the rotor body. Contact between rotor and stator is through the non conducting bearing oil film [7]. Rotor shaft is earthen by an additional brush used to discharge static electricity induce in turbine rotor by steam friction thus preventing pitting of bearing surface.

In brushless design, direct detection of rotor earth fault is impossible. Vibration detector is employed to initiate tripping. Rotating diodes are protected by fuses and fuse failure protection is also provided.

2.3.3.5.1 Dc Detector

Dc detector has the high resistance connected across the rotor circuit. The earth is connected through the sensitive relay coil at the center point of the resistance. Field winding center point being at equipotential with the midpoint of the resistor has blind spot under earth fault condition [7]. One half of the resistor is replaced by non linear resistor since it changes its value for different rotor voltage. It will continuously vary the effective resistor tapping voltage as the field condition change. There by avoiding blind spot. See figure 8:

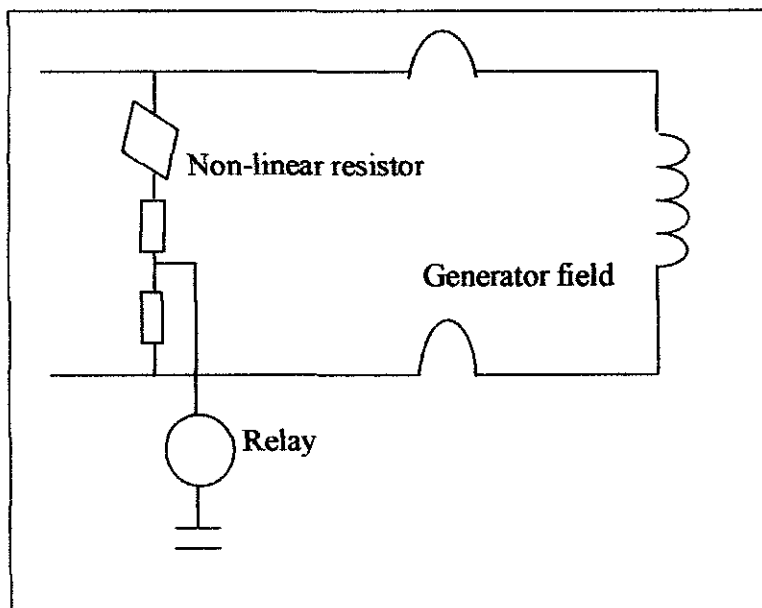

Figure 8: DC Detector

2.3.3.5.2 AC Detector

Ac detector has a small power pack (single phase ac full wave bridge rectifier) connected to the positive pole of the field circuit via a fault detecting relay. A fault at any point in the field system will pass the sufficient magnitude through the relay to cause operation. See figure 9.

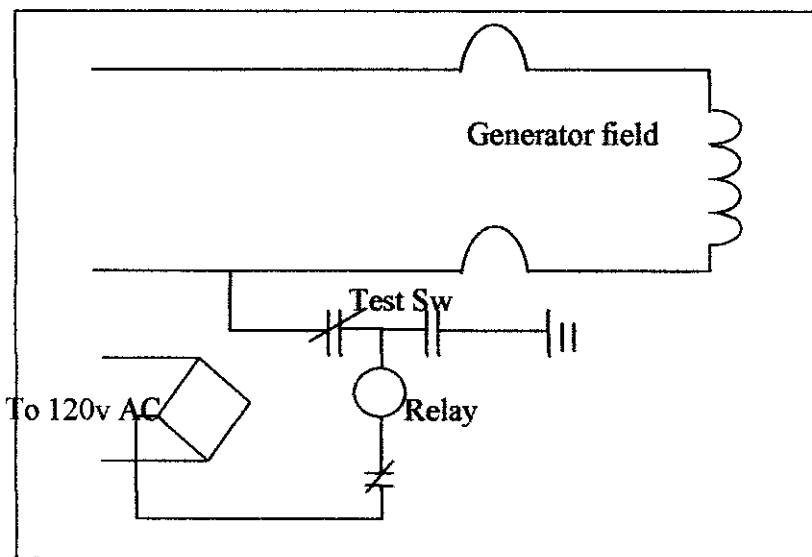

Figure 9: AC detector

2.3.3.8 Reverse power protection

Detect prime mover failure such as engine turbine by measuring the power drawn by the generator when motoring. Watt metric relay and time lag relay are used to prevent operation due to power swings.

2.3.3.9 Overload protection

Overload protection provides back up protection for bus or feeder faults. To use over current relay alone is difficult since the generators synchronous impedance limit the sustained fault current to the rated current.

A voltage controlled over current relay or an impedance relay is used. The relay will not operate until the voltage is reduced by the fault. Incorrect trip may occur on inadvertent loss of voltage supply [6].

2.3.3.10 Pole slipping protection

In large generator, severe mechanical torque oscillations accompany pole slipping, require prompt action to prevent damage [6]. Pole slipping does not occur if the system fault is cleared by high speed main protection.

Pole slipping either between generator and the system or between two sections of the system will result in a flow of synchronizing power, which reverses in direction twice every slip cycle [6]. It is characterized by a cyclic change in effective load impedance as measured at the terminals of the two asynchronous systems.

Pole slipping relays detect the first pole slip condition when a slip in a range of $\pm 0.1\%$ to 10% on a 50Hz basis. Protection remains unprotected for steady state loading, power swings and correctly cleared system fault conditions.

2.3.3.11 Stator open circuit protection

Open circuit in one of the stator winding will cause single phasing of generator and high negative sequence current. This will cause an alarm to alert the operator of the condition.

2.3.3.12 Overheating protection

Overheating may occur because of:

- a. Overload - high active power load coupled with high excitation.
- b. Failure of the ventilation or hydrogen cooling system.
- c. Shorted lamination in the stator iron.
- d. Core bolt insulation failure in the stator iron.

Alarm is used to let the operator to know if there are serious problem. At unattended stations, the output of the temperature indicator may be used to shut down the unit

2.3.3.13 Unbalance current protection

Unbalance of load can cause negative sequence current to flow in stator winding. These currents are reflected to the rotor as double frequency current in the rotor iron, which can cause severe rotor heating and may soften or weaken the slot edge and retaining rings [6].

The unbalance current may causes:

- a. One open phase of a line
 - b. One open pole of the circuit breaker
 - c. Close in unbalance fault that is not promptly cleared
 - d. Stator winding fault.
- } external failure
} to the machine

2.3.3.14 Backup protection

Negative sequence relay is considered as backup protection since most faults should be cleared by stator differential protection. There are 2 types of backup protection apply to the generator:

1. Backup of relays protecting the generator protection zone.
2. Backup of relays protecting external zone.

2.3.3.15 Shorted field winding protection

In generator field winding, the shorted turns have the potential for distorting the field across the air gap. This is because the unsymmetrical ampere turns of in different parts of field winding. If the air gap flux is badly distorted, the very distorted forces acting on the rotor. The unbalance force on rotor is severe vibration. This will cause damage to the baring. Vibration detector is used to spare the machine from serious damage.

2.3.3.16 Open field winding

Open field can do great damage to the rotor iron but this field winding open circuit are rare. Open circuit that does not involve ground can cause a sudden drop in field current that can be detected by loss of field relay.

2.3.3.17 Overheating of the field winding

The temperature of the field winding can be monitored by an ohmmeter that can measure the winding resistance of the field.

2.3.3.18 Over speed protection

Over speed will cause overvoltage which can be protected using overvoltage relay. However, over speed control is part of the turbine control system. Most large steam turbine controls have two or three separate speed control units. Over speed protection must be selective and must not shut the unit down due to temporary loss of load even if the cause is serious.

Most large steam turbine units have protective device that are design to distinguish between a loads rejection and a fault. Both will cause over speed and sudden loss of generated power. Fault will cause increase in current and load rejection will cause decrease in current [7].

Over speed protection is provide on the prime mover. Turbine is more sensitive to over speed. Over speed limiting gear detect sudden loss and closes emergency valve immediately to limit the magnitude of the temporary speed rise [6].

Generator electrical output is monitored using a watt metric relay, to detect sudden loss of output and operate instantaneously to close its contact. A second relay monitors turbine steam output at the chosen stage, closes when the steam pressure in full load region.

A sudden loss of load causes instantaneous operation of output relay but the steam input relay does not operate because steam is being admitted to and expand in the turbine. Under this condition, emergency valve solenoid is energized giving instantaneous control of steam admission. The emergency valve remains close until falling pressure of restoration of load restores in the machine to normal condition. Over speed limiting equipment operates additionally the interceptor emergency stop valves [6].

2.3.3.19 Generator motoring protection

Motoring protection is providing for the steam, hydraulic turbine or power system but not for generators. The protections is usually considered as part of generator protective system since it used electrical quantities usually in form of sensitive power relays.

2.3.3.20 Vibration protection

Vibration protection is a backup for faults that cause unbalance rotor heating due to rotor fault negative sequence rotor heating. It is important that there be coordination between the electrical protection and the mechanical backup.

2.3.3.21 Bearing failure protection

Bearing temperature can be measure by a temperature sensitive device that place in the bearing. This measurement can actuate the alarm to alert the operator if there are unwanted situations. It also can be used to trip the units. Some units, the bearings are lubricating by oil that is circulated through the bearing under pressure. In this case, the temperature of the oil can be monitored.

CHAPTER 3

METHODOLOGY

3.1 PROCEDURE IDENTIFICATION

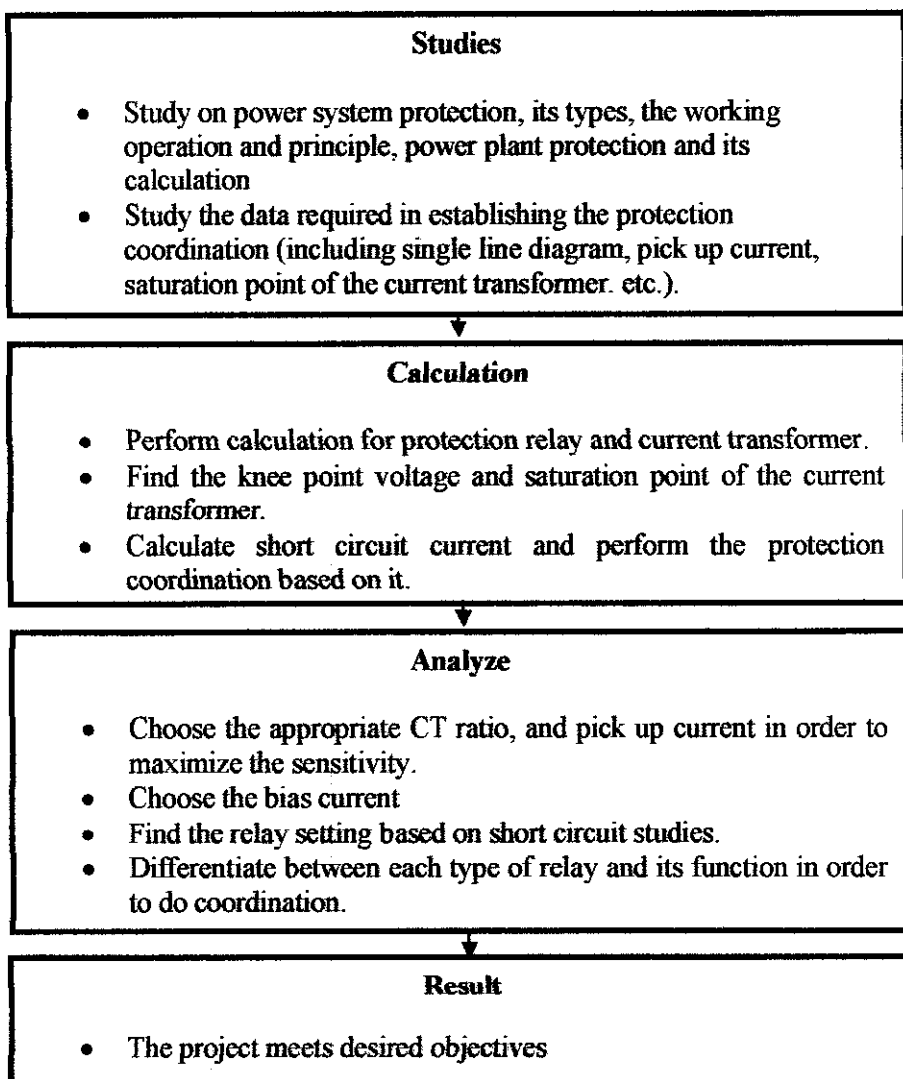

Figure 10: Methodology of Work

3.2 CALCULATION

3.2.1 Nominal Current

Nominal current, $I = ((\text{Rated power}) / (\sqrt{3} * \text{Rated Voltage}))$

Dividing the rated power by square root of three is because the system is three phase.

3.2.2 Differential Relay

We set the ratio of the differential relay is depends on the nominal current. Then we calculate for fault current. To calculate the fault current, first select the base power and also base voltage. Then, find the p.u reactance according to the selected based

Reactance, p.u = (actual reactance*(based power / rated power))

Finding the total impedance, example

0.03 is parallel with 0.024 and 0.025

0.024 And 0.025 are connected in series, so:

0.025

Finding $Z_t = ((0.03) (0.024+0.025)) / (0.03+0.024+0.025)$

$$= 0.019 \text{ p.u}$$

Fault current, $I_f = 1.0 / Z_t \text{ p.u}$

Calculate for the base current, $I = (\text{base power} / \sqrt{3} * \text{base voltage})$

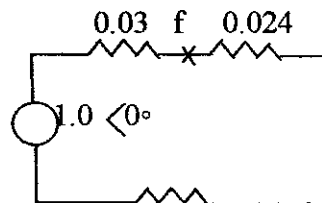

So, actual fault current = (base current * fault current p.u)

To find the secondary current of the current transformer, we divided the current with the CT ratio.

Then we need to find the knee point voltage, the bias current and also the differential current to know the saturation point. Further details about these are being discussed in chapter four (result and discussion).

CHAPTER 4

RESULT AND DISCUSSION

4.1 NOMINAL CURRENT

4.1.1 Generator

Generator rating: 617.7 MVA, 3-phase, 22 kV, $X_d'' = 0.2, 0.85, 50$ Hz

Current, $I = 617.7 \text{ MVA} / (\sqrt{3} * 22\text{kV})$

= 16 209 amps

4.1.2 Generator Transformer

Generator transformer rating: 590 MVA, 290 kV / 22kV, $z = 14\%$

High voltage side

Current, $I = 590 \text{ MVA} / (\sqrt{3} * 290 \text{ kV})$

= 1 174.61 amps

Low voltage side

$$\text{Current, } I = 590 \text{ MVA} / (\sqrt{3} * 22\text{kV})$$

$$= 15\,483 \text{ amps}$$

4.1.3 Generator Transformer Unit Auxiliary

Generator unit rating: 59 MVA, 22 kV / 11.7 kV, Z = 15%

High voltage side

$$\text{Current, } I = 59 \text{ MVA} / (\sqrt{3} * 22 \text{ kV})$$

$$= 1\,548.3 \text{ amps}$$

Low voltage side

$$\text{Current, } I = 59 \text{ MVA} / (\sqrt{3} * 11.7 \text{ kV})$$

$$= 2\,911.42 \text{ amps}$$

4.2 DIFFERENTIAL RELAY

The winding and also the stator core will get damage when there are failures in stator winding or connection insulation occur. The damage will depends on the amount of the fault current and the duration of the fault.

Protection must be as sensitive as possible to detect the lowest fault current in the same time remain stable under all permissible load, overload, and through-fault conditions.

4.2.1 Generator

Heavy through current because of the external fault current will cause one of the current transformers, CT to saturate more than the other. This will cause the difference of the secondary current produce by each CT. The protection need to be stabilizes for this condition.

For this relay, we can use a biasing technique where the relay setting is increase as the through current increase. The through current is calculated as the average of the scalar sum of the current entering and the current leaving the protection zone. The calculated current then used to apply the percentage bias to increase the percentage setting.

For this generator, the differential protection operating characteristic is as shown in figure 11.

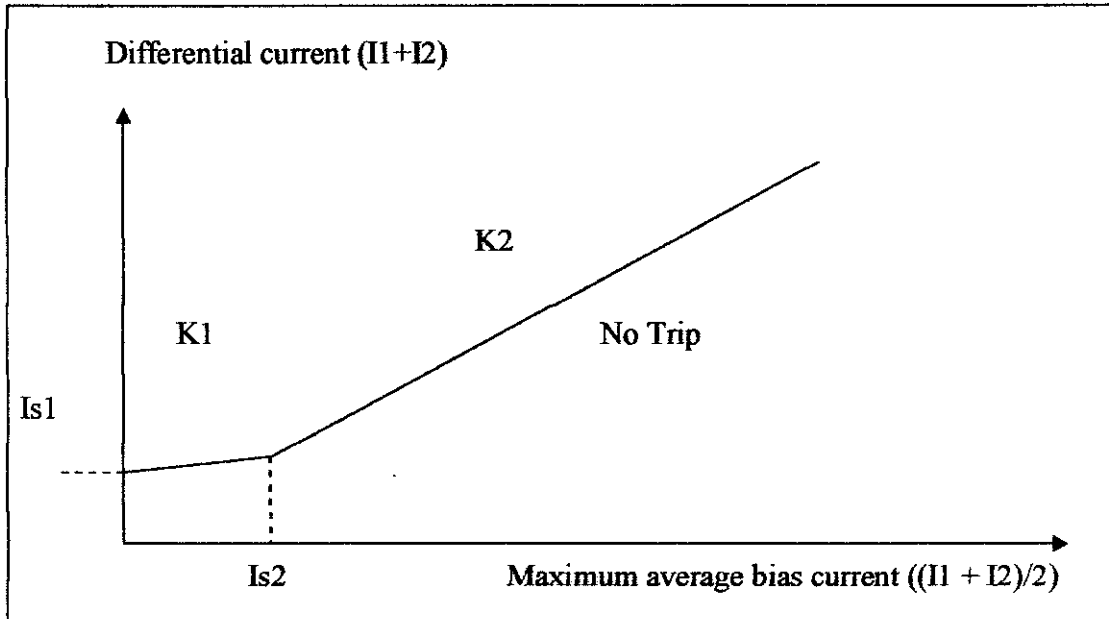

Figure 11: Generator Differential Protection Operation Characteristic

The initial percentage bias slope, K_1 is applied for through current up generator differential current, I_{s2} . The second percentage bias slope, K_2 is applied for through currents above the generator differential, I_{s2} setting.

I_{s1} should be set to a low setting to protect as much as machine winding. The setting should be set 5% of the rated current of the machine (CT secondary rated current) which is 5 amps. The initial percentage bias slope can be set from 0% to 20% to provide optimum sensitivity for internal fault. The second percentage bias slope may typically be set to 80%. The higher slope provides stability for external fault especially if the generator CTs saturate.

The setting of Is2 should be set 120% of the machine rated current. In this case:

$$\begin{aligned} I_{s1} &= (0.05) (5) & I_{s2} &= (1.2) (5) \\ &= 0.25 \text{ amps} & &= 6.0 \text{ amps} \end{aligned}$$

$$\begin{aligned} I_{\text{bias}} &= (0.25 + 6.0) / 2 \\ &= 3.125 \text{ amps} & I_{\text{bias}} &\leq I_{s2} \end{aligned}$$

$$\begin{aligned} I_{\text{diff}} &> ((K1) (I_{\text{bias}})) + I_{s1} \\ &> ((0) (3.125 \text{ amps})) + 0.25 \\ &> 0.25 \end{aligned}$$

4.2.1.1 Calculation

Nominal current = 16 209 amps

CT ratio given = 20 000: 5

CT secondary current = $(16\ 209 / (20\ 000 / 5))$

$$= 4.052$$

Calculate fault current

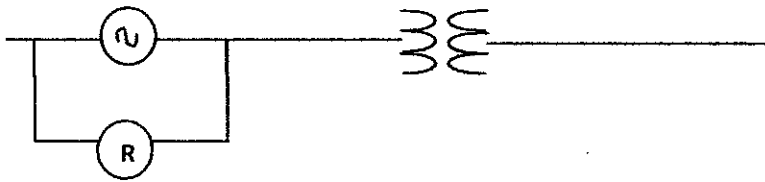

Generator rating	gen transformer rating	system
617.7 MVA, 22 kV	590 MVA, z = 14%	x = 0.025
0.85, Xd' = 0.2	290 kV / 22 kV	

Taking 100 MVA and 22 kV as base to find p.u

Generator impedance = $(0.2) (100\ \text{MVA} / 617.7\ \text{MVA})$

$$= 0.03\ \text{p.u}$$

Generator transformer impedance = $(0.14(100\ \text{MVA}/590\ \text{MVA})) = 0.024\ \text{p.u}$

System impedance = 0.024

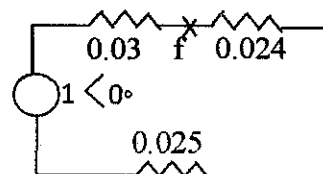

$$\text{Finding } Z_t = ((0.03) (0.024+0.025)) / (0.03+0.024+0.025)$$

$$= 0.019 \text{ p.u}$$

$$\text{Current fault, } I_f = 1.0 / 0.019$$

$$= 52.63 \text{ p.u}$$

Finding base current and actual fault current

$$\text{Base current, } I = (100 \text{ MVA} / (\sqrt{3} * 22 \text{ kV}))$$

$$= 2\,624.32 \text{ amps}$$

$$\text{Fault current, } I_f = (2\,624.32 \text{ amps}) (52.63 \text{ p.u})$$

$$= 138.18 \text{ k amps}$$

Using CT ratio of 20 000:5

$$\text{CT secondary current} = (138.18 \text{ k amps}) / (20\,000/5)$$

$$= 34.545 \text{ amps}$$

$$(34.545 / 5) = 6.909 \approx 7 \text{ times higher than rated secondary current for CT.}$$

Fault at generator side

$$\text{Fault current at generator side} = ((52.63) (0.025+0.024)) / (0.025+0.024+0.03)$$

$$= 32.64 \text{ p.u}$$

$$\text{Actual fault current at the generator side} = (32.64 \text{ p.u}) (2\,624.32 \text{ amps})$$

$$= 85.66 \text{ k amps}$$

$$\text{CT secondary current} = (85.66 \text{ k amps}) / (20\,000 / 5)$$

$$= 21.415 \text{ amps}$$

Fault at system side

$$\text{Fault current at system side} = ((52.63) (0.03)) / (0.025+0.024+0.03)$$

$$= 19.99 \text{ p.u}$$

$$\text{Actual fault current at the system side} = (19.99 \text{ p.u}) (2\,624.32 \text{ amps})$$

$$= 52.46 \text{ k amps}$$

$$\text{CT secondary current} = (52.46 \text{ k amps}) / (20\,000 / 5)$$

$$= 13.115 \text{ amps}$$

CT saturation point

CT rating: 3 phase, 20 000:5, 5P10, 200 VA, relay impedance = 1.5 ohms, and the lead impedance = 0.2

The percentage error of this CT is not more than 5% and the saturation limit factor is 10.

$$\text{Knee point voltage} = (10) (200 \text{ VA} / 5) = 400 \text{ V.}$$

The secondary current imposed 400 V across the CT given by

$$(\text{Knee voltage}) / (\text{relay impedance} + \text{lead impedance}) = (400) / (1.5 + 0.2)$$

$$= 235.29 \text{ amps} \quad \approx 48 \text{ times greater than rated current.}$$

4.2.2 Generator Transformer

4.2.2.1 Calculation

Calculate fault current

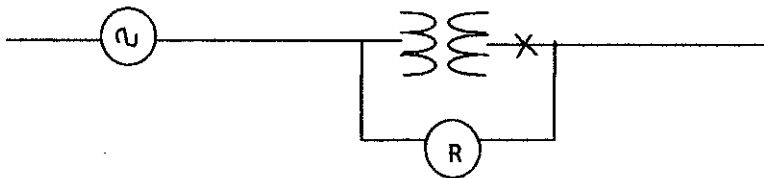

Generator rating	gen transformer rating	system
617.7 MVA, 22 kV	590 MVA, z = 14%	x = 0.025
0.85, Xd'' = 0.2	290 kV / 22 kV	

Nominal current at primary side

$$590\text{MVA} / (\sqrt{3} * 290 \text{ kV}) = 1174.61 \text{ amps}$$

The CT rating is 1500: 5

The secondary CT current is $(1174.61) / (1500 / 5) = 3.91 \text{ amps}$

Taking 100 MVA and 290 kV as base to calculate the impedance

Generator impedance: $(0.2) (100 \text{ MVA} / 617.7 \text{ MVA}) = 0.03 \text{ p.u}$

Generator transformer impedance: $(0.14(100\text{MVA}/590 \text{ MVA})) = 0.024 \text{ p.u}$

System impedance = 0.024

Finding $Z_t = ((0.03 + 0.024)(0.025)) / (0.03 + 0.024 + 0.025)$

= 0.017 p.u

Current fault, $I_f = 1.0 / 0.017 = 58.23$ p.u

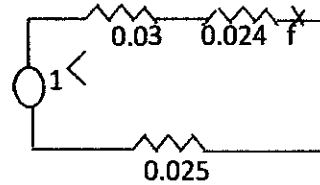

Finding base current and actual fault current

Base current, $I = (100 \text{ MVA} / (\sqrt{3} * 290 \text{ kV}))$

= 199.1 amps

Fault current, $I_f = (199.1 \text{ amps}) (58.23 \text{ p.u})$

= 11.629 k amps

Using CT ratio of 1 500:5

CT secondary current = $(11.629 \text{ k amps}) / (1 500/5)$

= 38.76 amps

$(38.76 / 5) = 7.75 \approx 8$ times higher than rated secondary current for CT.

Fault at generator transformer side

Fault current at generator transformer side

$$\begin{aligned} &= ((58.23) (0.025)) / (0.025+0.024+0.03) \\ &= 18.43 \text{ p.u} \end{aligned}$$

Actual fault current at the generator transformer side

$$= (18.43 \text{ p.u}) (199.1 \text{ amps})$$

$$= 3.680 \text{ k amps}$$

$$\text{CT secondary current} = (3.680 \text{ k amps}) / (1\ 500 / 5)$$

$$= 12.27 \text{ amps}$$

Fault at system side

$$\text{Fault current at system side} = ((58.23) (0.03 + 0.024)) / (0.025+0.024+0.03)$$

$$= 39.8 \text{ p.u}$$

$$\text{Actual fault current at the system side} = (39.8 \text{ p.u}) (199.1 \text{ amps})$$

$$= 7.924 \text{ k amps}$$

$$\text{CT secondary current} = (7.924 \text{ k amps}) / (1\ 500 / 5)$$

$$= 26.41 \text{ amps}$$

4.2.2.2 Interposing Current Transformer

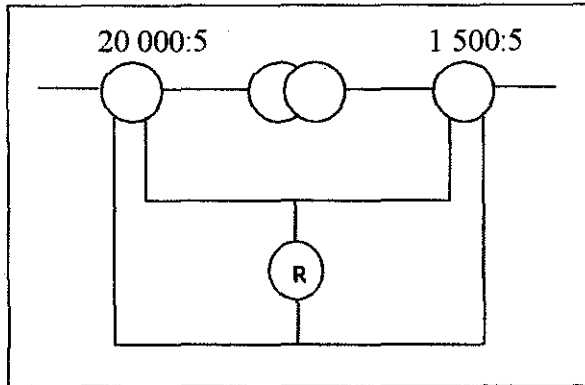

Figure 12: Generator Transformer Differential Relay

The transformer differential relays compare the phase and magnitude of current entering one winding of the transformer with the one leaving the transformer. The difference between this two current will cause the relay to operate and if the current exceed the relay setting, the transformer will trip.

Since the rated currents that entering and leaving the differential relay will not exactly the same with the rated current at the generator transformer, they used the interposing current transformer to balance back the current so that the line current transformer, CT will match to the normal full load current of the transformer.

4.2.2.2.1 Calculation for interposing current transformer

Table 2: Interposing Current Transformer that Available for Current Ratio and Phase Angle Matching with Line CTs Used with Transformer Differential Relay Type MCB[11]

Description		Reference number
single-phase transformer	0.577 - 1.732/1A	GJ0104 010
single-phase transformer	2.886 - 8.66/5A	GJ0104 020
single-phase transformer	2.886 - 8.66/1A	GJ0104 030
three-phase transformer group	0.577 - 1.732/1A	GJ0104 050
three-phase transformer group	2.886 - 8.66/5A	GJ0104 060
three-phase transformer group	2.886 - 8.66/1A	GJ0104 070

Table 3: Details of the Number of Turns on Each of the Transformers Noted in Table 2[11]

Primary Winding Taps	Number of Turns		
	Transformer rating		
	0.577 - 1.732 / 1A	2.886 - 8.66 / 1A	2.886 - 8.66 / 5A
1 - 2	5	1	1
2 - 3	5	1	1
3 - 4	5	1	1
4 - 5	5	1	1
5 - 6	125	25	25
X - 7	25	5	5
7 - 8	25	5	5
8 - 9	25	5	5
S1 - S2	125	125	25
S3 - S4	90	90	18

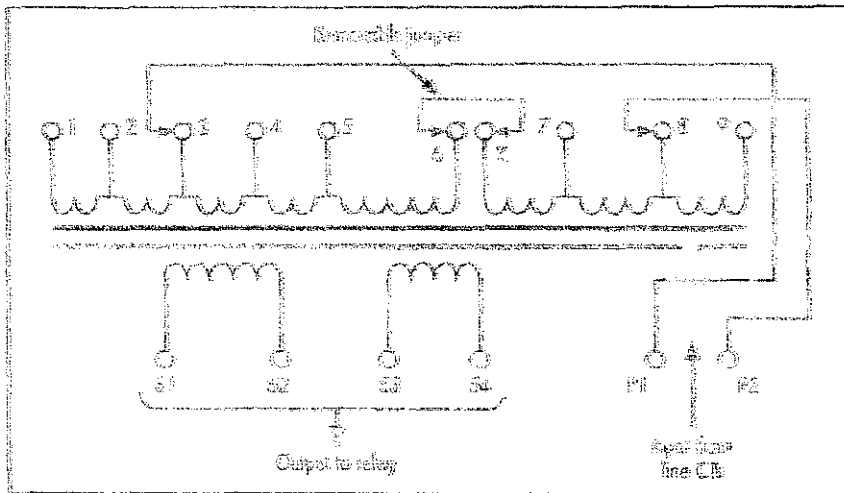

Figure 13: Disposition of Windings on Interposing Transformer [11]

Transformer rating: 3 phase, star delta, 590 MVA, 290 kV / 22 kV

Current transformer rating at primary side 1 500:5

Current transformer rating at secondary side 20 000:5

At primary side of the transformer

Nominal current: $590\text{MVA} / (\sqrt{3} * 290 \text{ kV}) = 1\ 174.61 \text{ amps}$

During rated load condition, the following current per pilot:

$$1\ 174.61 / (1\ 500/5) = 3.915 \text{ amps}$$

At secondary side of the transformer

Nominal current: $590\text{MVA} / (\sqrt{3} * 22 \text{ kV}) = 15\ 483 \text{ amps}$

The output of the secondary current transformers will be:

$$15\,483 / (20\,000/5) = 3.871 \text{ amps}$$

- Thus, the required ratio for the interposing current transformers is 3.871:3.915. Refer to figure 13, the output to the relay are (S1 – S2) and (S3 – S4). Based from the table, using output winding (S1 – S2) and (S3 – S4) connection in series gives $25 + 18 = 43$ turns.
- The input winding turns will be :

$$((43) (3.915)) / (\sqrt{3} * 3.871) = 25.11 \text{ turns} \approx 26 \text{ turns.}$$

The generator transformer is star delta connection and the interposing CT is connected at the star winding of the generator transformer. In this case, the star delta interposing current transformer is being used so that the phase and amplitude of the current can be corrected.

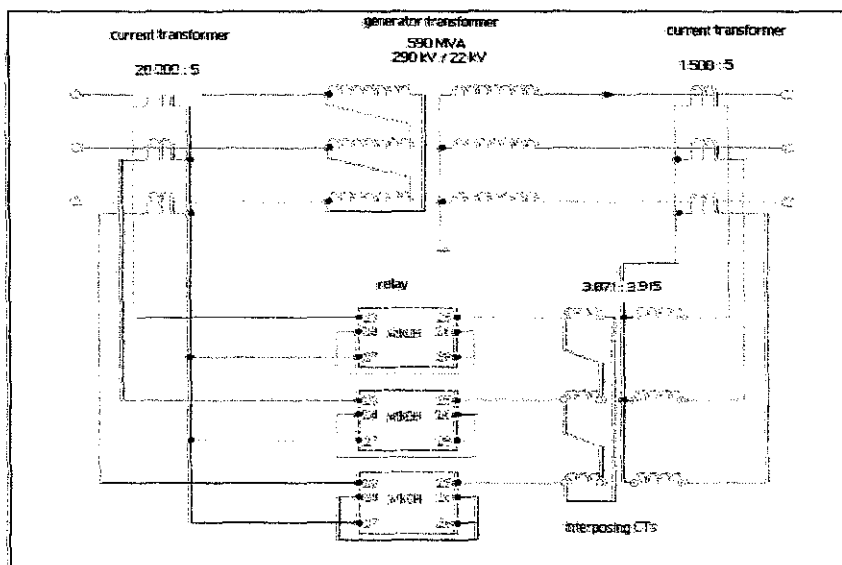
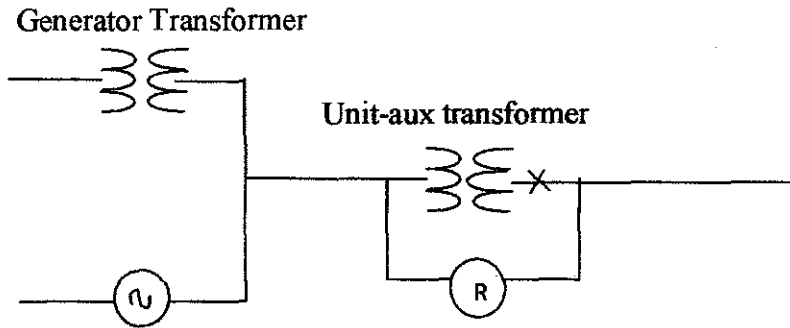

Figure 14: Interposing CTs Connection [11]

4.2.2.3 Unit auxiliary transformer

4.2.2.3.1 Calculation

Fault current calculation



Generator rating	gen transformer rating	unit- aux transformer
617.7 MVA, 22 kV	590 MVA, z = 14%	59MVA, 22kV / 11.7 kV
0.85, Xd'' = 0.2	290 kV / 22 kV	15.5 %

Nominal current at secondary side

$$59\text{MVA} / (\sqrt{3} * 11.7 \text{ kV}) = 2\,911.42 \text{ amps}$$

The CT rating is 3 700: 5

The secondary CT current is $(2\,911.42) / (3\,700 / 5) = 3.93 \text{ amps}$

Taking 100 MVA and 11.7 kV as base to calculate the impedance

Generator impedance: $(0.2) (100 \text{ MVA} / 617.7 \text{ MVA}) = 0.03 \text{ p.u}$

Generator transformer impedance: $(0.14(100\text{MVA}/590 \text{ MVA})) = 0.024 \text{ p.u}$

Unit- aux = $((0.155) (100\text{MVA}/59\text{MVA})) = 0.26 \text{ p.u}$

System impedance = 0.024

Finding Z = $((0.025 + 0.024) (0.03)) / (0.03+0.024+0.025)$

= 0.019 p.u

$Z_t = 0.26 + 0.019 \text{ p.u} = 0.279 \text{ p.u}$

Current fault, $I_f = 1.0 / 0.279 = 3.58 \text{ p.u}$

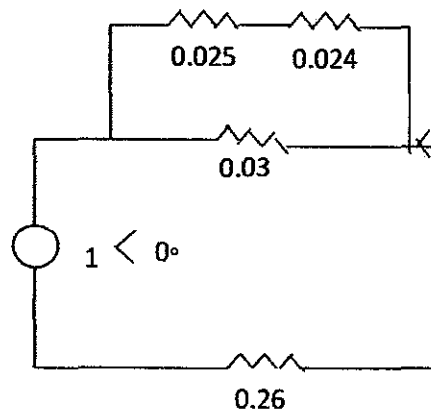

Finding base current and actual fault current

Base current, $I = (100 \text{ MVA} / (\sqrt{3} * 11.7 \text{ kV}))$

= 4 934.46 amps

Fault current, $I_f = (4 934.46 \text{ amps}) (3.58 \text{ p.u})$

= 17.665 k amps

Using CT ratio of 3 700:5

CT secondary current = $(17.665 \text{ k amps}) / (3 700/5)$

= 23.87 amps

$(23.87 / 5) = 4.774 \approx 5$ times higher than rated secondary current for CT.

4.2.2.3.2 Bias differential element

In this relay, there are 2 bias input per phase for two phase winding transformer [12]. In unit-aux transformer, bias differential protection is used to eliminate the use of interposing current transformer. Bias differential protection being used with restricted earth fault protection to cover the large percentage of transformer winding.

Figure 15 show the bias differential characteristic.

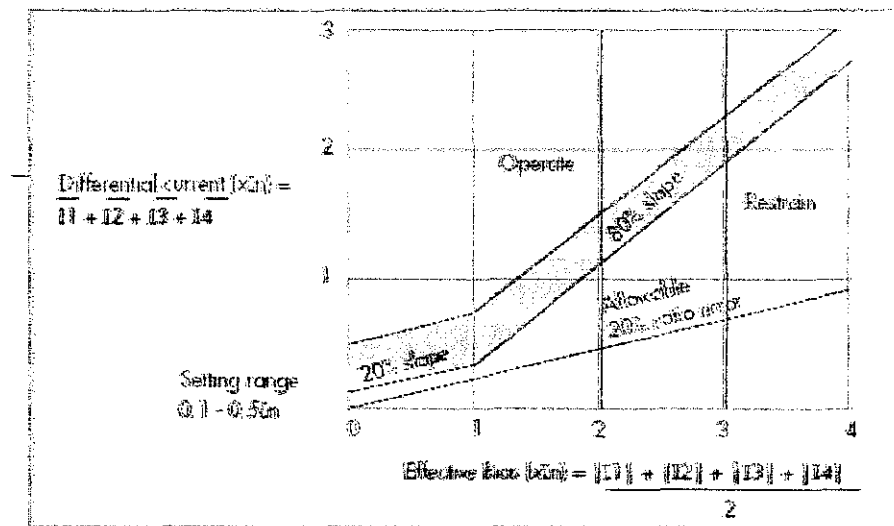

Figure 15: Biased Differential Characteristic[12]

Minimum differential current is set between 10% and 50% of the rated current. The rated current is 5A. So, the minimum differential current is between 0.5 amps and 2.5 amps. The slope is set to 20% from zero to the rated current to ensure the sensitivity to the internal fault and also to allow the current transformer

(CTs) ratio errors. Besides, it is to allow up to 15% mismatch when the generator transformer is at the limit of its tap changing [12].

When the differential current is over the rated current (5 amps), error will increase. This will cause the current transformer to be saturate. To encounter this problem, the bias slope is increase to 80%.

This bias differential protection include with magnetizing inrush element and also selectable over fluxing element [12]. These elements are installed to slow down the relay during the heavy internal fault and to prevent from unwanted tripping due to this condition.

4.3 STATOR EARTH FAULT

Stator earth fault is current operated and can be typically set to 95% of the stator winding. It is usually used resistive earthed generator. Besides, it also is used to respond to current in the secondary current in secondary circuit of an earthing transformer loaded with a resistor. A time delayed low set element and an instantaneous high set element are provided.

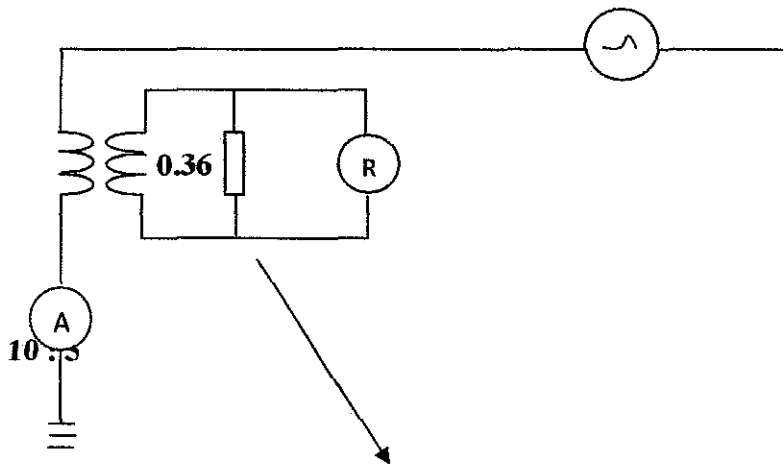

Distribution transformer rating

Max current rating = 381 amps

22 kV / 240 V

= 0.36 ohms

280 kVA, 50 Hz

Primary voltage of the distribution transformer = line-neutral voltage rating of the generator.

CT ratio of the generator = 20 000:5

Maximum current = $381 / (20\ 000/5)$

= 0.0095 this current does not enough to operate differential relay of the generator

Secondary resistor = 0.36 ohms

Primary resistor = $(0.36) (22\text{kV}/240\text{V})^2$

$$= 3025 \Omega$$

Generator ground current, $I = V/R$

$$= 22\text{kV} / 3025$$

$$= 7.27 \text{ amps}$$

We can select the CT A ratio of 10:5

The secondary CT A current is = $7.27 / (10/5)$

$$= 3.64 \text{ amps}$$

Relay current, $I_n = 5 \text{ A}$

TMS setting = 4 sec

Current setting $I_e > 0.005 I_n - 0.1 I_n$

$$> 0.005(5) = 0.025$$

Time characteristic is DT – definite time. The setting time is 4 seconds. The relay will trip directly after 4 seconds.

4.4 LOW FORWARD / REVERSE POWER RELAY

The reverse power relay is used to detect loss in prime mover. The failure in the prime mover can be detected by the power drawn by the generator when motoring. The power setting can be chosen from 1W – 40W since the relay is a 5A relay. Choosing the lowest value of power setting which is 1W to optimize sensitivity of the relay. The time delay can be set from 0.5s – 10s.

The low forward relay is used in steam turbine generator to avoid overspeeding. The low forward power interlock is used in turbine to supply electrical power so that the generator is acting as a break and providing non-urgent tripping condition. The power setting is chosen to be 1W to maximize sensitivity of the relay.

4.5 VOLTAGE DEPENDENT OVERCURRENT RELAY

Voltage dependent overcurrent relay is another backup system. The relay will trip if the fault has not been cleared by another protection. So, the relay operating time is slightly higher than the other protection relay. In Kapar Energy Ventures, the generators are connected to the bus bar via step up transformer, so the voltage dependent overcurrent function is voltage restrain mode. In this mode, the current pick up level is proportionally lowered as the voltage falls below the setting point. But since the timing characteristic is definite time, the graph of the voltage restrain mode is as below. The relay will trip after the setting time which is 3 sec.

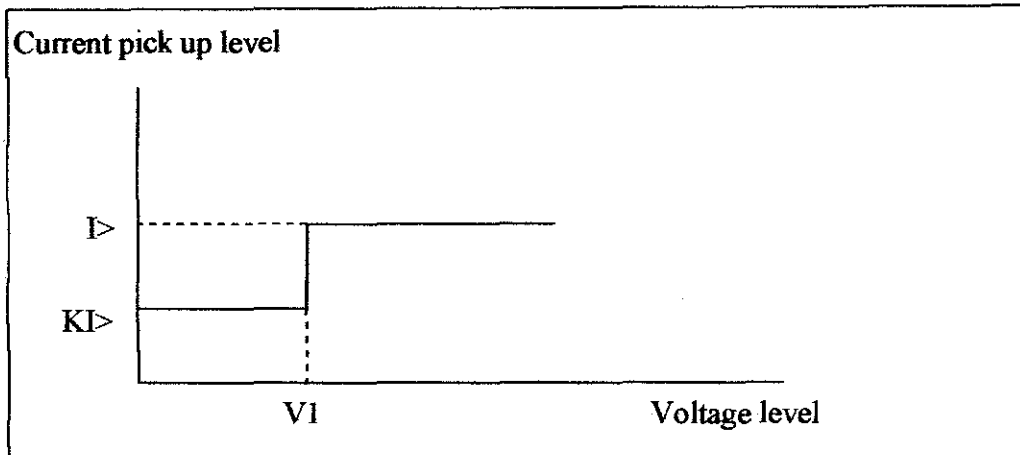

Figure 16: Voltage Restrain Mode Definite Time Characteristic

$$\begin{aligned}
 I> & \quad \text{for} \quad V > V1 \\
 KI> + ((I> - KI>)/(V1 - V2)) * (V - V2) & \quad \text{for} \quad V1 < V < V2 \\
 KI> & \quad \text{for} \quad V < V1
 \end{aligned}$$

Since the time characteristic is definite time, there is no value of $V2$.

The voltage $V1$ can be set between 20V – 120V. The setting voltage $V1 = 88V$. Value of the rated current is 5A. Current $I>$ can be set from 0.5*rated current to 2.4*rated current. Taking 1.3*rated current, $I> = 6.5A$. K factor can be set from 0.25 to 1.00. We take the lowest value of K to increase sensitivity of the relay when the voltage drops below the setting value. Taking the value of $K=0.25$, $KI> = 1.625$. If the current value is above 1.625 below the setting voltage above 4 seconds, the relay will trip. Same goes if the current is above 6.5A above the voltage setting point.

4.6 NEGATIVE PHASE SEQUENCE RELAY

Negative phase sequence relay will detect the unbalance load condition. Overheating can occur due to induced eddy current in rotor. This function has thermal replica curve which simulates the effect of the pre-fault heating due to low level of standing negative phase sequence current, I_2 .

When I_2 value is above the threshold, the thermal replica, $t = K/I_2^2$ K is the generator's per-unit current thermal capacity constant in seconds. In this negative phase sequence relay, the thermal capacity constant for heating, K can be set from 2s to 40s and for the constant for cooling, K reset is from 2s to 60s. K reset is used when the generator is cooling and will cause the reduction of I_2 . This is to provide the rotor components with differing cooling time constant.

When the high value of K is being select and the negative phase sequent currents measured are near to the threshold, the operating time may be too slow. So, in this case, the setting time will be maximums. T_{max} can be set from 500s to 2000s. in this relay, the T_{max} setting = 2000s. The maximum setting time is to provide a safe trip time.

The operating time will become too fast when the value of I_2 is high. This will cause the loss of discrimination with other power protection under fault condition. To overcome this situation, the inverse characteristic is provided with an adjustable minimum operating time setting, T_{min} . T_{min} can be set from 0.25s to

40s. Set to the low value to optimize sensitivity of the relay. T min is set to 0.5s. Alarm is also provided in this relay with definite time output for pre-trip warning purpose.

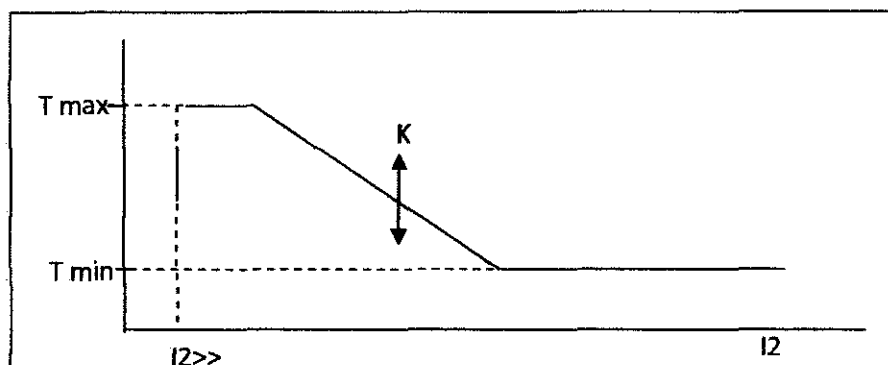

Figure 17: Negative Phase Sequence Characteristic

For tripping element

$I_{2>>}$ can be set from $0.05 \times \text{rated current}$ to $0.5 \times \text{rated current}$. The rated current = 5A.

Operating characteristic, $t = - (K/I_{2>>}^2) \times \log_e(1 - (I_{2>>}/I_2)^2)$

taking $K = 5s$, $I_{2>>} = 0.3A$ and $I_2 = 0.9$

For alarm element

I_2 can be set from $0.03 \times \text{rated current}$ to $0.5 \times \text{rated current}$ and the alarm setting can be set from 2s to 60s.

4.7 FIELD FAILURE RELAY

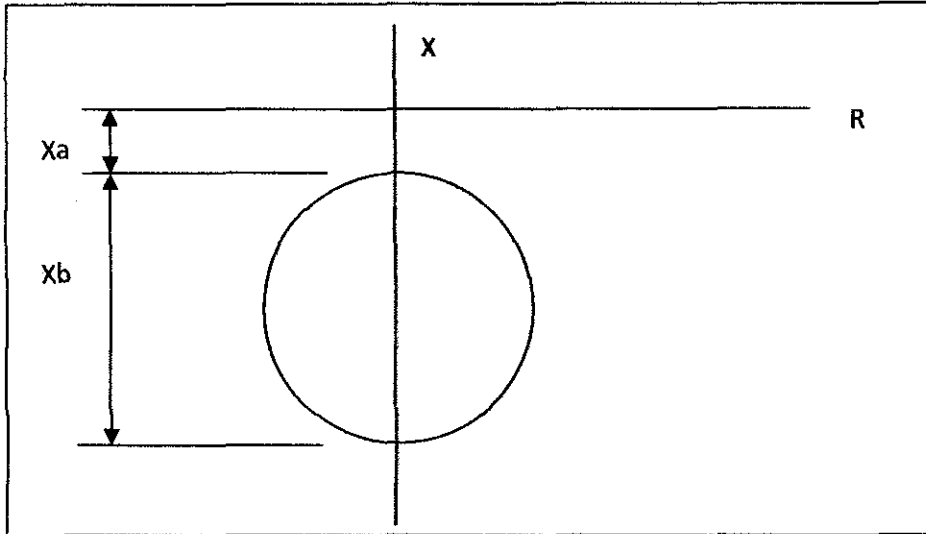

Figure 18: Field Failure Protection Characteristic (mho characteristic)

This field failure protection relay is provided with single phase impedance measuring element. This single phase impedance has an offset mho characteristic as figure 18. Filed failure protection relay are used to protect the loss of excitation due to field failure. This failure can cause a large number of reactive current which can endanger the generator.

- X_a = Mho offset

X_b = Mho diameter

An integrating timing arrangement is also provided to allow the relay to trip within the setting time even though the impedance may fall outside the mho characteristic temporarily for example under pole slipping condition. Time delay pick up timer can be set between 0 to 25 sec and drop off timer can be set from 0 to 5 sec.

-Xa can be set between 0.5Ω - 5Ω .

Injection test on stage Xa

$X_a = V/(I*\sqrt{3})$. For example , voltage inject , $V = 5$, pick up current = 1.962amps
the Mho offset = 1.471Ω

Injection test on stage Xa + Xb

$X_a + X_b = V/(\sqrt{3}*I)$, voltage inject = 20V , pick up current = 0.383amps

: $X_a + X_b = 29.7\Omega$.

4.8 OVER VOLTAGE RELAY

Over voltage relay are used for backup system for speed control governor and automatic voltage regulator. If there are overvoltage occur, the high set of the element can provide fast operation. The rated voltage here is 110V. There are two types of overvoltage for generator protection. One is 59.1. The setting voltage is 140V. If the voltage is higher than 140 V in 3 sec, the relay will operate. The other one is 59.2. The setting current is higher than the first one. The setting current is 160V, so the time delay is lesser to prevent from further damage. The time delay is 0.5 sec. Both of the relay time delay can be set between 0 to 10 seconds depends on the voltage setting and the relay capability. Both elements are three phase device.

CHAPTER 5

CONCLUSIONs AND RECOMMENDATION

5.1 CONCLUSIONS

This project is to studies on protection component in power plant and also protection coordination. The project achieves its objectives as author understands the types of fault and failure that occurs in power plants. Besides, the author understands the concept of generator and generator protection and can analyze the setting of the current transformer. Furthermore, several calculations has been done such as calculation for fault current, the bias setting for differential relay and also interposing current transformer for all the generator, generator transformer and also unit auxiliary transformer in order to understand and analyze the setting of current transformer and relay.

The pickup current for most of the relay is taken 5% - 10% of the rated current. The low value of the pickup current is to optimum the sensitivity for the fault. Relay operating characteristic must be carefully coordinated in order to achieve selectivity and basically to switch off only the faulted component in order to minimize the interruptions and assure stability. Failure of stator winding, or connection insulation, can result in severe damage to the windings and stator core. The extent of damage depends upon the fault current level and the duration of the

fault. Interposing Current transformer and bias differential relay are used to balance the current so that the line current transformer, CT will match to the normal full load current of the transformer.

5.2 RECOMMENDATIONS

This project is a good approach for generator protection studies at Kapar Energy Ventures (KEV). This can contribute in reducing cost for hiring external expertise thus enhancing the reliability of the generator. For more improvement, some additional research could be added in order to make the system more efficient and user friendly.

REFERENCE

- [1] Operation Manual Sultan Salahuddin Abdul Aziz Power Station PH3 Tenaga Nasional Berhad (TNB)
- [2] SMD, "Electrical Protection Relay Study (KNPG-B)", 2008
- [3] Mohd Faris Bin Abdullah, "Protection Relay Coordination and Protection Equipment Commissioning Testing of the 22kV Main Switching Station (SSU) Satera Maju Project, Tenaga Nasional (TNB) Ipoh, Perak", *IEM Professional Interview Report*, 1998
- [4] "Distribution Protection System", Unit Perlindungan (Kedah/Perlis) Tenaga Nasional Berhad
- [5] Distribution Protection, Coordination of Protection Devices
- [6] Protection Device and Controller
- [7] Dr. Ravindra Mukerjee, "Generator and Generator Transformer Protection"
- [8] ERACS user manual
- [9] Abdullah bin Abdul Rahman , " Transformer Protection" , University Tenaga Nasional.
- [10] Copper Power System, Inc. 1997 <
<http://www.cooperpower.com/library/pdf/15032.pdf>>.

[11] **ALSTOM T&D Protection and Control Ltd** <<http://www.aveva.com/solutions/global/docs/legacyproducts/mbch1213sales1en.pdf>>.

[12] **ALSTOM Transmission and Distribution Protection and Control Ltd.**
<http://www.aveva.com/solutions/US_448_US::Solutions::Automation::KBCH+120.+130.+140+.htm>.

APPENDIXES

Detail/ Week	1	2	3	4	5	6	7	8	9	10	11	12	13	14	15
1 Selection of Project Topic															
2 Preliminary Research Work															
3 Submission of Preliminary Report				•											
4 Studies on generator															
5 Studies on types of fault															
6 Studies on Generator protection															
7 Submission of Progress Report								•							
8 Gathering the data needed															
10 Submission of Interim Report Final Draft														•	
11 Submission of Interim Report															•

Gantt chart for FYP1

No.	Detail/ Week	1	2	3	4	5	6	7	8	9	10	11	12	13	14
1	Study on generator protection														
2	Start calculation														
3	Submission of progress report II				•										
4	Analyze the setting														
5	Submission of draft report II							•							
6	Final report (soft bound)										•				
7	Submission of technical report										•				
8	Recommendations and conclusion														
9	Oral presentation														•
10	Submission of final report (hard cover)														•

Gantt chart for FYP2

G. H. Liew Engineering (1990) Sdn. Bhd.

No. 25, Jalan 7/6, Seksyen 7, 46050 Petaling Jaya.
Tel: 03-79542675, 79548675, 79545270 Fax: 03-79548450
Web Address: <http://ghliew1990.com>

Generator Protection LGPG11 (-F60) Protection List

Job No : 3578/2002 - 12
Client : TNB Generation Sdn. Bhd
Installation : SSAA Power Station Phase 3 - GT5, 525MW, KAPAR

Relay Details :

Make	: GEC	Model	: LGPG11101555MEB
Serial No	: 630494H	Aux Voltage	: 250Vdc
Volt Rated	: 110Vac	Amp Rated	: 5 A

Settings List

System Data:

Plant Reference	LGPG111 Relay												
Model No.	LGPG11101555MED												
Serial No.	630494H												
Frequency	50Hz												
Comms Level	1												
Relay Address	1												
Active Setting Group	1												
Software Ref 1	18 LGPG002 XXX EG												
Software Ref 2	18 SCM001 002D												
Logic I/P Status													
Relay O/P Status													

Transformer Ratios:

Display Value	SECONDARY												
Current Rating	5A												
Diff. CT Ratio	4000 / 1												
Sensitive Ia CT Ratio	4000 / 1												
Residual CT Ratio	4000 / 1												
Earth CT Ratio	2.0 / 1												
Earth VT Ratio	200 / 1												
Phase CT Ratio	4000 / 1												
Phase VT Ratio	200 / 1												
Comp VT Ratio	200 / 1												

Protection FN Status

Generator Differential Earth Fault Protection	86 G Gen Diff	ENABLE
	51N>SEF Low Set	ENABLE
	51N>> SEF High Set	DISABLE
	59N Neutral Disp	ENABLE
	67N SDEF	DISABLE
Dependent Over current	51V OC	ENABLE
Power protection	32R Reverse Pwr	ENABLE
	32L Low Fwd Pwr	ENABLE
Frequency Protection	81U-1 UF	ENABLE
	81U-2 UF	ENABLE
	81O OF	DISABLE
Voltage protection	27 UV	DISABLE
	59 OV	ENABLE
	60 Voltage BLN	ENABLE
Negative Phase Sequence	46 Neg. Ph Seq.	ENABLE
Field Failure	40 Field Failure	ENABLE

Generator Differential 87G (percentage relay)

1	0.25A
1)	0%
2	6.0A
2)	150%

Neutral DISP 59N

se>	3.4 KV (17V)
	4.0 sec
	4.0 sec
Reset	0 sec

Dependent OC 51V

1	CONTROL
operate	Yd
S1	88V
S2	-
	0.25
char.	DT
	6.5A
MS	3.0 sec
reset	0 sec

Low Forward Power 32L

<	1 W
	2.0sec
DO	0 sec
comp	-

Under Voltage 27

<	-
	-

Negative Phase sequence 46N

	0.2 A
	3.0 sec
>>	0.3A
	5.0 sec
max	2000 sec
min	0.5 sec
reset	5.0 sec

Earth Fault 51N

Char (SI/DT)	DT
Ie	0.175A
TMS	4.0 sec
TReset	0 sec
Ie>>	-
t>>	-

Voltage Balance 60

Vs >	10 V

Reverse Power 32R

Comp.	0 DEGREE
-P>	1.0W
T	10.0 sec
tDO	0 sec

Under Frequency 81U-1&2

F1	47.5 Hz
t1	10 sec
F2	47.1Hz
t2	0.1sec

Over Voltage 59

V>	140V
t>	3 sec
V>>	160V
t>>	0.5 sec

Field Failure 40

-Xa	1.5 Ohm
Xb	28.2 Ohm
t	2.0 sec
tdo	0 sec

Checked By: KC WONG
DATE:24-4-2002

G. H. Liew Engineering (1990) Sdn. Bhd.

No. 25, Jalan 7/6, Seksyen 7, 46050 Petaling Jaya.

Tel: 03-79542675, 79548675, 79545270 Fax: 03-79548450

Web Address: <http://ghliew1990.com>

Generator Differential Relay test Report.

Job No : 3578/2002 - 12A
Client : TNB Generation Sdn. Bhd
Installation : SSAA Power Station Phase 3 - GT5, 525MW, KAPAR
Circuit : MULTI FUNCTION GEN. PROT. (BACKUP) LGPG111-2

Relay Details :

Make	: GEC	Model	: LGPG11101S555MEB
Serial No	: 630494H	Aux Voltage	: 250Vdc
Code No	: 87G	Rated Current	: 5A

Relay Settings :

Description	Setting
Is1 Setting	0.25 A
K1 Setting	0%
Is2 Setting	6.0 A
K2 Setting	150%

Injection test :

Job	Element	Pick up (A)	Expected (A)
1	Ph A	0.267	0.25
2	Ph B	0.251	0.25
3	Ph C	0.264	0.25

Timing test.

Job	Element	Operating time (sec)	Expected (sec)
1	Ph A	0.037	Instant
2	Ph B	0.038	Instant
3	Ph C	0.041	Instant

Indication : OK
Output : R6
Remark : MAINTENANCE
Tested by : KC WONG
Date : 8-04-2002

Certified by,

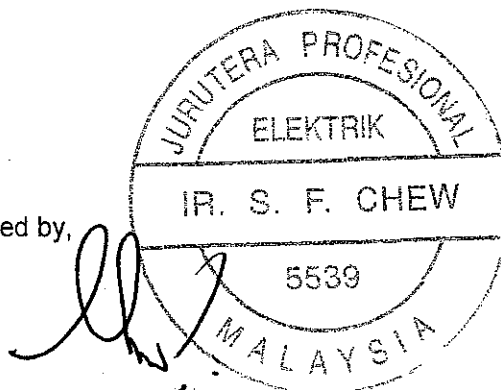

G. H. Liew Engineering (1990) Sdn. Bhd.

G. H. Liew Engineering (1990) Sdn. Bhd.

No. 25, Jalan 7/6, Seksyen 7, 46050 Petaling Jaya.
 Tel: 03-79542675, 79548675, 79545270 Fax: 03-79548450
 Web Address: http://ghliew1990.com

*

Low Forward / Reverse Power Relay test Report.

o No : 3578/2002 - 12B
 ent : TNB Generation Sdn. Bhd
 tallation : SSAA Power Station Phase 3 - GT5, 525MW, KAPAR
 uit : MULTI FUNCTION GEN. PROT. (BACKUP) LGPG111-2

ay Details :

ke	: GEC	Model	: LGPG11101S144LEB
ial No	: 630494H	Aux Voltage	: 250Vdc
de No	: 32	Rated Current	: 5A

ay Settings :

o	Stage	Description	Setting Value 32R	Setting Value 32L
	32	Power Setting	1.0 W	1.0 W
		Time Delay	10 sec	2.0 sec
		Time (Drop Off)	0 sec	0 sec

action test :

Stage	Pickup (W)	Drop-off (W)	Expected (W)
32R	1.03	0.75	1.0
32L	1.0	1.2	1.0

ing test :

Stage	Operating time (sec)	Expected (sec)
32R	10.03	10.0
32L	2.02	2.0

↑ kno die charge

lication : OK
 itput : R2, R13
 mark : MAINTENANCE
 sted by : KC WONG
 te : 8-04-2002

Certified by,

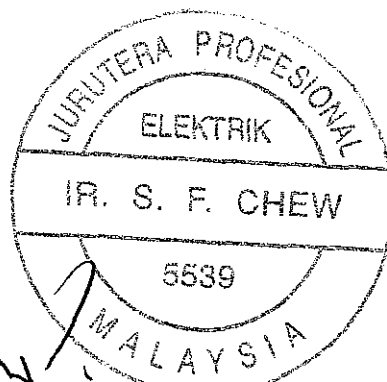
G. H. Liew Engineering (1990) Sdn. Bhd.

G. H. Liew Engineering (1990) Sdn. Bhd.

No. 25, Jalan 7/6, Seksyen 7, 46050 Petaling Jaya.

Tel: 03-79542675, 79548675, 79545270 Fax: 03-79548450

Web Address: <http://ghliew1990.com>

Field Failure Relay test Report.

Job No : 3578/2002 - 12C
Client : TNB Generation Sdn. Bhd
Installation : SSAA Power Station Phase 3 - GT5, 525MW, KAPAR
Circuit : MULTI FUNCTION GEN. PROT. (BACKUP) LGPG111-2

Relay Details :

Make	: GEC	Model	: LGPG11101555MED
Serial No	: 630494H	Aux Voltage	: 250Vdc
Code No	: 40	Rated Current	: 5 Amp

Relay Settings :

Id	Stage	Description	Setting Value
1	40	Xa	1.5Ω
		Xb	28.2Ω
		Time Delay	2.0secs
		Time (Drop-off)	0.1secs

Injection test on stage Xa + Xb :

Phase	Voltage (V)	Pick up Current (A)	Calculate(Ω): $Xa+Xb=V / (I \times \sqrt{3})$	Expected (Ω)
RYB	20	0.383	30.14	29.7

Injection test on stage Xa :

Phase	Voltage (V)	Pick up Current (A)	Calculate (Ω): $Xa=V / (I \times \sqrt{3})$	Expected (Ω)
RYB	5	1.962	1.47	1.5

Timing test.

Stage	Operating time (sec)	Expected time (sec)
Xa +Xb	2.0	2.0
Xa	2.0	2.0

Indication : OK
Output : R4
Remark : MAINTENANCE
Tested by : KC WONG
Date : 8-04-2002

Certified by,

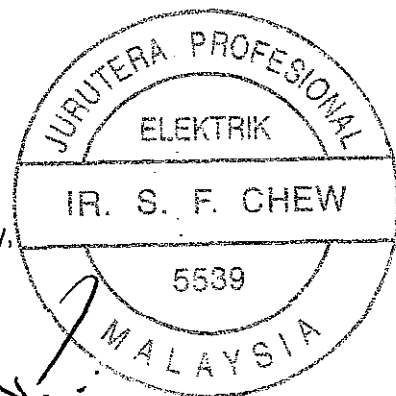
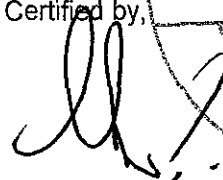

G. H. Liew Engineering (1990) Sdn. Bhd.

G. H. Liew Engineering (1990) Sdn. Bhd.

No. 25, Jalan 7/6, Seksyen 7, 46050 Petaling Jaya.
Tel: 03-79542675, 79548675, 79545270 Fax: 03-79548450
Web Address: <http://ghliew1990.com>

Stator Earth Fault test Report.

o No : 3578/2002 - 12D
ent : TNB Generation Sdn. Bhd
tallation : SSAA Power Station Phase 3 - GT5, 525MW, KAPAR
cuit : MULTI FUNCTION GEN. PROT. (BACKUP) LGPG111-2

lay Details :

ke	: GEC	Model	: LGPG 111 01555 MED
ial No	: 630494H	Aux Voltage	: 250Vdc
DE	: 51N		

lay Settings :

Description	Setting
$I_e >$	0.175A
TMS	(4 sec)
t RESET	0 sec
haracteristic	DT

ection Test :

Description	Pickup (A)	Drop Off (A)	Expected (A)
urrent Injected	0.175	0.160	0.175

ing Test:

Description	Operating Time (sec)	Expected (sec)
10 X $I_e >$	4.00	4.0

lication : OK
rput contact: R14
mark : MAINTENANCE
sted by : KC WONG
te : 8-04-2002

Certified by,

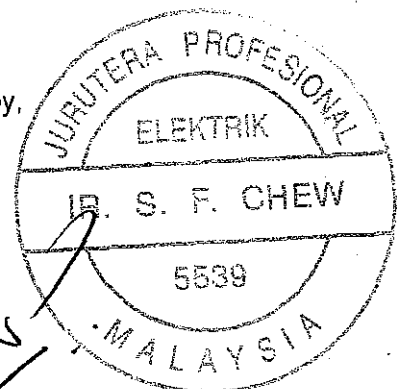

G. H. Liew Engineering (1990) Sdn. Bhd.

G. H. Liew Engineering (1990) Sdn. Bhd.

No. 25, Jalan 7/6, Seksyen 7, 46050 Petaling Jaya.
Tel: 03-79542675, 79548675, 79545270 Fax: 03-79548450
Web Address: <http://ghliew1990.com>

Neutral Displacement Relay Test Report.

Job No : 3578/2002 - 12E
Client : TNB Generation Sdn. Bhd
Installation : SSAA Power Station Phase 3 - GT5, 525MW, KAPAR
Circuit : MULTI FUNCTION GEN. PROT. (BACKUP) LGPG111-2

Relay Details :

Make	: GEC	Model	: LGPG11101555MEB
Serial No	: 630494H	Aux Voltage	: 250Vdc
Code No	: 59N	Rated Current	: 5A

Relay Settings :

No	Stage	Description	Setting Value
1	59N-1	Ve> setting	17V
		Time Delay t1	4 sec
2	59N-2	Ve>>	17 V
		Time Delay t2	4 sec
		Reset Time	0 sec

Action Test :

Description	Pickup (V)	Drop Off (V)	Expected (V)
59N-1	16.94	16.83	17
59N-2	16.94	16.83	17

Timing Test:

Description	Operating Time (sec)	Expected (sec)
59N-1	4.01	4.0
59N-2	4.01	4.0

Indication : OK
Output : R11
Remark : MAINTENANCE
Tested by : KC WONG
Date : 8-04-2002

Certified by

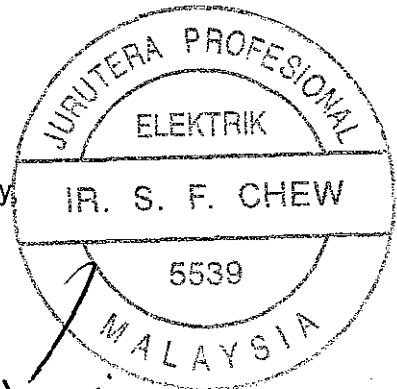

G. H. Liew Engineering (1990) Sdn. Bhd.

G. H. Liew Engineering (1990) Sdn. Bhd.

No. 25, Jalan 7/6, Seksyen 7, 46050 Petaling Jaya.
 Tel: 03-79542675, 79548675, 79545270 Fax: 03-79548450
 Web Address: <http://ghliew1990.com>

Voltage Dependent O/C Relay test Report.

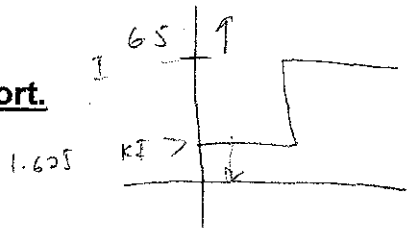

Job No : 3578/2002 - 12F
 Client : TNB Generation Sdn. Bhd.
 Installation : SSAA Power Station Phase 3 - GT5, 525MW, KAPAR.
 Circuit : MULTI FUNCTION GEN. PROT. (BACKUP) LGPG111-2

Relay Details :

Make	: GEC	Model	: LGPG11101555MEB
Serial No	: 630494H	Aux Voltage	: 250Vdc
Code No	: 51V	Rated Current	: 5A

Relay Settings :

Description	Setting Value
VS 1	88V
VS 2	
K	0.25
CHAR	DT
I >	6.5A
T	3 sec

Voltage controlled mode

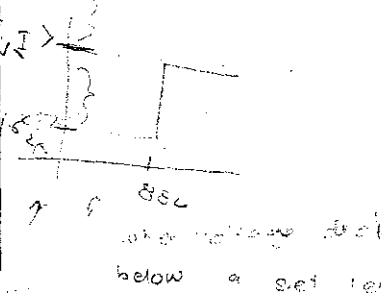

VS = 250V - 120V

Action test :

Phase	Voltage Injected (V)	Expected Current (A)	Pick-up (A)	Drop-off(A)	Operating time at 2x I> (sec)
B, C	120	6.5	6.52	6.46	3
B, C	65	1.625	1.682	1.532	3
B, C	15	1.625	1.65	1.53	3

Indication : OK
 Output : R3
 Remark : MAINTENANCE
 Tested by : KC WONG
 Date : 8-04-2002

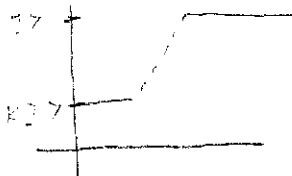

Voltage restrain

Certified by,

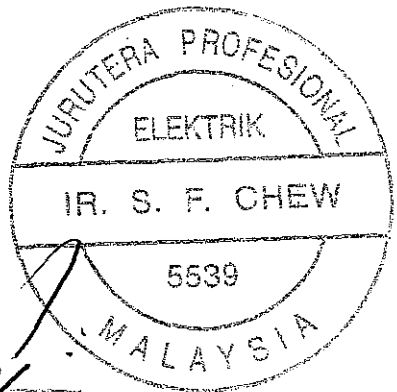

G. H. Liew Engineering (1990) Sdn. Bhd.

G. H. Liew Engineering (1990) Sdn. Bhd.

No. 25, Jalan 7/6, Seksyen 7, 46050 Petaling Jaya.
Tel: 03-79542675, 79548675, 79545270 Fax: 03-79548450
Web Address: <http://ghliew1990.com>

✦ Negative Phase Sequence Relay test Report.

Job No : 3578/2002 - 12G
Client : TNB Generation Sdn. Bhd.
Installation : SSAA Power Station Phase 3 - GT5, 525MW, KAPAR.
Circuit : MULTI FUNCTION GEN. PROT. (BACKUP) LGPG111-2

Relay Details :

Make	: GEC	Model	: LGPG11101555MEB
Serial No	: 630494H	Aux Voltage	: 250Vdc
Code No	: 46	Rated Current	: 5A

Relay Settings :

Stage	Description	Setting Value
46> Alarm	I2> setting	0.2A
	t>	3.0 sec
46>> trip	I2>> setting	0.3 A
	K3	5 sec
	T _{max}	2000 sec
	T _{min}	0.5 sec
	K _{reset}	5 sec

46>> trip (lowest value)
 46>> trip (lowest value)

Injection test :

Characteristic & operating time for 46> NPS Alarm

Phase Injected	Expected current (A)	Pick-up (A)	Drop-off(A)	Operating time (sec)
A-N	0.6	0.606	0.595	3.04

Characteristic & operating time for 46>> NPS trip

Phase injected	Expected current (A)	Pick-up (A)	Expected time (sec)	Operating time (sec) at 4xI2>>
A-N	0.9	0.90	89.58	94.28

Indication : OK
Output : R8, R5
Remark : MAINTENANCE
Tested by : KC WONG
Date : 8-04-2002

Certified by,

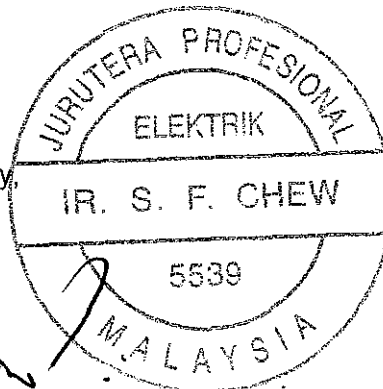
.....
G. H. Liew Engineering (1990) Sdn. Bhd.

G. H. Liew Engineering (1990) Sdn. Bhd.

No. 25, Jalan 7/6, Seksyen 7, 46050 Petaling Jaya.
Tel: 03-79542675, 79548675, 79545270 Fax: 03-79548450
Web Address: <http://ghliew1990.com>

Under Frequency Relay test Report.

Job No : 3578/2002 - 12H
Client : TNB Generation Sdn. Bhd
Installation : SSAA Power Station Phase 3 - GT5, 525MW, KAPAR
Circuit : MULTI FUNCTION GEN. PROT. (BACKUP) LGPG111-2

Relay Details :

Make	: GEC	Model	: LGPG11101555MEB
Serial No	: 630494H	Aux Voltage	: 250Vdc
Code No	: 81U.1 & 81U.2	Rated Current	: 5 A

Relay Settings :

Description	Setting
Frequency Setting, F1<	47.5 Hz
Time Delay, t1	10 sec
Frequency Setting, F2<	47.1 Hz
Time Delay, t2	0.1 sec

Injection Test :

Description	Pickup (Hz)	Drop Off (Hz)	Expected (Hz)
81U.1	47.49	47.50	47.5
81U.2	47.08	47.13	47.1

Timing Test:

Description	Operating Time (sec)	Expected (sec)
81U.1	10.44	10.0
81U.2	0.2	0.1

Indication : OK
Output : R15, R12
Remark : MAINTENANCE
Tested by : KC WONG
Date : 8-04-2002

Certified by

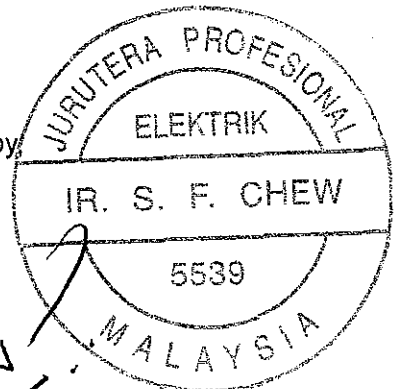

G. H. Liew Engineering (1990) Sdn. Bhd.

G. H. Liew Engineering (1990) Sdn. Bhd.

No. 25, Jalan 7/6, Seksyen 7, 46050 Petaling Jaya.
Tel: 03-79542675, 79548675, 79545270 Fax: 03-79548450
Web Address: <http://ghliew1990.com>

Over Voltage Relay test Report.

Job No : 3578/2002 - 121
Client : TNB Generation Sdn. Bhd
Installation : SSAA Power Station Phase 3 - GT5, 525MW, KAPAR
Circuit : MULTI FUNCTION GEN. PROT. (BACKUP) LGPG111-2

Relay Details :

Make	: GEC	Model	: LGPG11101555MEB
Serial No	: 630494H	Aux Voltage	: 250Vdc
Code No	: 59.1 & 59.2	Rated Voltage	: 110Vac

Relay Settings :

No	Stage	Description	Setting Value
1	59.1	Voltage Setting	140 V
		Time Delay	3.0 sec
2	59.2	Voltage setting	160 V
		Time Delay	0.5 sec

Injection Test :

Description	Pickup (V)	Drop Off (V)	Expected (V)
59.1	140.2	140.1	140
59.2	160.78	160.23	160

Timing Test:

Description	Operating Time (sec)	Expected (sec)
59.1	3.0	3.0
59.2	0.53	0.5

Indication : OK
Output : R7
Remark : MAINTENANCE
Tested by : KC WONG
Date : 08-04-2002

Certified by

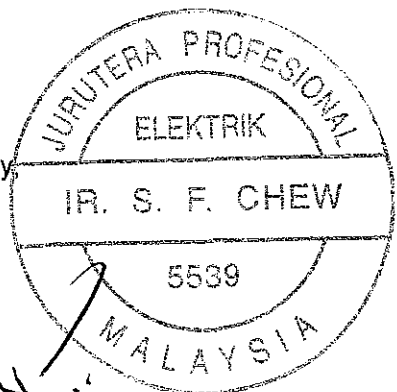

G. H. Liew Engineering (1990) Sdn. Bhd.

G. H. Liew Engineering (1990) Sdn. Bhd.

No. 25, Jalan 7/6, Seksyen 7, 46050 Petaling Jaya.

Tel: 03-79542675, 79548675, 79545270 Fax: 03-79548450

Web Address: <http://ghliew1990.com>

Voltage Balance Relay test Report.

(code:60)

Job No : 3578/2002 - 12J
Client : TNB Generation Sdn. Bhd
Installation : SSAA Power Station Phase 3 - GT5, 525MW, KAPAR
Circuit : MULTI FUNCTION GEN. PROT. (BACKUP) LGPG111-2

Relay Details :

Make	: GEC	Model	: LGPG 11101 555MED
Serial No	: 630494H	Rated Current	: 5A
Code	: 60	Rated Voltage	: 110Vac

Relay Settings :

Description	Setting
Over Voltage Setting	10 V

Secondary Injection Tests :

Phase	Pick-up Value (V)	Drop-off Value(V)	Remark	Expected (V)
V1(R-Y)	100	101.1	V2 =110V	100
V1(B-R)	100.3	101.0	V2 =110V	100
V2(R-Y)	100.1	101.0	V1 =110V	100
V2(B-R)	100.	101.0	V1 =110V	100

Indication : OK
Output Contact : R1
Remarks : MAINTENANCE
Tested by : KC WONG
Date : 08-04-2002

Certified by

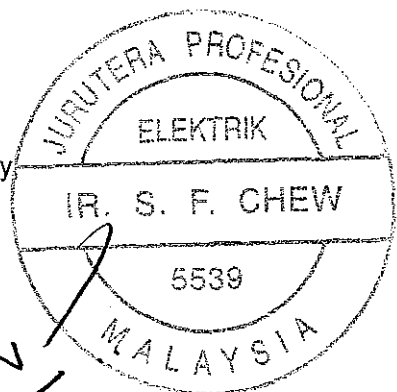

G. H. Liew Engineering (1990) Sdn. Bhd.

G. H. LIEW ENGINEERING (1990) SDN. BHD.
POLE SLIP TEST REPORT
(CODE:78)

Job No. : 3578/2002-13A
 Client : TNB Generation Sdn. Bhd
 Installation : SSAA Power Station Phase 3 - GT5, 525MW, KAPAR
 Circuit : SSA PH3 REG316 VARIANT 4 UNIT 5 78 POLE SLIP

Relay Details :

Make	: ABB	Model	: REG316
Serial No	: -	Aux Voltage	: 250Vdc
Rated Current	: 5 A	Rated Voltage	: 110Vac

Settings :

	Description	Setting Value
1.	ZA	0.174 Ω
2.	ZB	- 0.179 Ω
3	ZC	0.146 Ω
4	Phi,	270 °
5	Scaling Factor, K	- 0.774

Injection Test For Pole Slip:

Description	Operation	3 phase current $I_{R,Y,B}$ (49.5Hz), A	3 phase volatge $V_{R,Y,B}$ (50Hz) V	Ω measured	Ω calculated
ZONE 1 $\theta = 90^\circ$	NO TRIP	2.67	8	-	- 0.182
	TRIP	2.69	8	-0.179	- 0.181
	TRIP	2.70	8	- 0.177	- 0.180
	TRIP	2.75	8	- 0.176	- 0.177
	TRIP	3.0	8	- 0.158	- 0.162
	TRIP	5.0	8	- 0.096	- 0.097
	TRIP	5.0	6	- 0.060	- 0.073
ZONE 2 $\theta = 270^\circ$	TRIP	5.0	8	0.096	0.097
	TRIP	4.0	8	0.119	0.121
	TRIP	3.34	8	0.142	0.145
	TRIP	3.30	8	0.146	0.147
	TRIP	3.28	8	0.147	0.148
	TRIP	2.75	8	0.172	0.177
	TRIP	2.74	8	0.173	0.177
	NO TRIP	2.73	8	0.175	0.178

Checking for Voltage Balance 60-3 Blocking = YES

Remarks : LED 3,6
 Tested by : KM SHEA
 Date : 16-04-2002

Certified by:

(Signature)

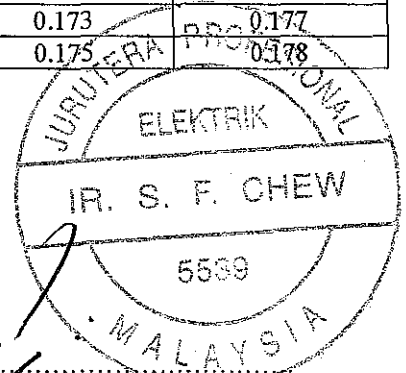

G.H. Liew Engineering (1990) Sdn. Bhd.

G. H. Liew Engineering (1990) Sdn. Bhd.

No. 25, Jalan 7/6, Seksyen 7, 46050 Petaling Jaya.
Tel: 03-79542675, 79548675, 79545270 Fax: 03-79548450
Web Address: <http://ghliew1990.com>

Voltage Balance Relay test Report.

(code:60)

Job No : 3578/2002-13B
Client : TNB Generation Sdn. Bhd
Installation : SSAA Power Station Phase 3 - GT5, 525MW, KAPAR
Circuit : SSA PH3 REG316 VARIANT 4 UNIT 5 60-3 VOLTAGE BALANCE

Relay Details :

Make	: ABB	Model	: REG316
Serial No	: -	Aux Voltage	: 250Vdc
Rated Current	: 5 A	Rated Voltage	: 110Vac

Relay Settings :

Description	Setting
Over Voltage Setting	0.1 Un
Time setting	0.04sec

Secondary Injection Tests : (V1 = VT5 , V2 = VT4)

Phase	Expected Value(V)	Pick-up Value (V)	Drop-off Value(V)	Remark
V1(R-Y)	11	11.15	9.92	V2 =0V
V1(Y-B)	11	11.17	9.93	V2 =0V
V1(B-R)	11	11.16	9.93	V2 =0V
V2(R-Y)	11	11.15	9.99	V1 =0V
V2(Y-B)	11	11.15	9.93	V1 =0V
V2(B-R)	11	11.15	10.0	V1 =0V

Timing Tests :

Voltage Injected (V)	Expected Time (Sec)	Operating Time (Sec)
13.2	0.04	0.04

Remarks : LED 4,5
Tested by : KM SHEA
Date : 16-04-2002

Certified by

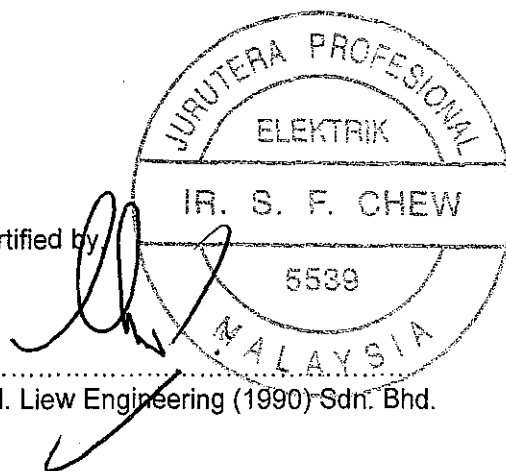

G. H. Liew Engineering (1990) Sdn. Bhd.

G. H. LIEW ENGINEERING (1990) SDN. BHD.
OVER EXCITATION PROTECTION (CODE 24)

Job No. : 3578/2002 - 13C
Client : TNB Generation Sdn. Bhd
Installation : SSAA Power Station Phase 3 - GT5, 525MW, KAPAR
Circuit : SSA PH3 REG316 VARIANT 4 UNIT 5 59/81-2 OVER EXCITATION

Relay Details :

Make	: ABB	Model	: REG316
Serial No	: -	Aux Voltage	: 250Vdc
Rated Current	: 5 A	Rated Voltage	: 110Vac

Settings :

	Description	Setting Value
1.	Voltage Freq	1.08 Un/Fn
2.	Time Delay	43 sec

Injection Test :

	Description	Expected Value	Measured Value
1.	Pick-up Voltage	118.8 V	119.0 V
2.	Time Delay	43.0 sec	43.01 sec

Remarks : LED 2, 4
Tested by : KM SHEA
Date : 16-04-2002

Certified by:

IR. S. F. CHEW

5539

G.H. Liew Engineering (1990) Sdn. Bhd.

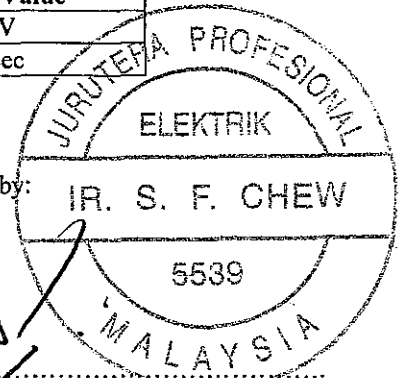

G. H. Liew Engineering (1990) Sdn. Bhd.

No. 25, Jalan 7/6, Seksyen 7, 46050 Petaling Jaya.
Tel: 03-79542675, 79548675, 79545270 Fax: 03-79548450
Web Address: <http://ghliew1990.com>

Generator Protection LGPG11 (-F60) Protection List

Job No : 3578/2002 - 14
Client : TNB Generation Sdn. Bhd
Installation : SSAA Power Station Phase 3 - GT5, 525MW, KAPAR

Relay Details :

Make	: GEC	Model	: LGPG11101555MEB
Serial No	: 630491H	Aux Voltage	: 250Vdc
Volt Rated	: 110Vac	Amp Rated	: 5 A

Settings List

System Data:

Plant Reference	LGPG111 Relay												
Model No.	LGPG11101555MED												
Serial No.	630491H												
Frequency	50Hz												
Volts Level	1												
Relay Address	1												
Protective Setting Group	1												
Software Ref 1	18 LGPG002 XXX EG												
Software Ref 2	18 SCM001 002D												
Logic I/P Status													
Relay O/P Status													

Transformer Ratios:

Display Value	PRIMARY
Current Rating	5A
Primary CT Ratio	4000 / 1
Sensitive Ia CT Ratio	4000 / 1
Residual CT Ratio	4000 / 1
Earth CT Ratio	2.0 / 1
Earth VT Ratio	200 / 1
Phase CT Ratio	4000 / 1
Phase VT Ratio	200 / 1
Impedance VT Ratio	200 / 1

Protection FN Status

Generator Differential	86 G Gen Diff	ENABLE
Earth Fault Protection	51N>SEF Low Set	ENABLE
	51N>> SEF High Set	DISABLE
	59N Neutral Disp	ENABLE
	67N SDEF	DISABLE
Dependent Over current	51V OC	ENABLE
Power protection	32R Reverse Pwr	ENABLE
	32L Low Fwd Pwr	ENABLE
Frequency Protection	81U-1 UF	ENABLE
	81U-2 UF	ENABLE
	81O OF	DISABLE
Voltage protection	27 UV	DISABLE
	59 OV	ENABLE
	60 Voltage BLN	ENABLE
Negative Phase Sequence	46 Neg. Ph Seq.	ENABLE
Field Failure	40 Field Failure	ENABLE

Generator Differential 87G

1	1.0 KA (0.25A)
1	0%
2	24 KA (6.0A)
2	150%

Neutral DISP 59N

se>	3.4 KV (17V)
	4.0 sec
	4.0 sec
Reset	0 sec

Dependent OC 51V

1	CONTROL
otate	Yd
S1	17.6KV (88V)
s2	-
	0.25
nar.	DT
	26KA (6.5A)
MS	3.0 sec
reset	0 sec

Low Forward Power 32L

0	0.8MW (1 W)
	2.0sec
DO	0 sec
comp	-

Under Voltage 27

	-
	-

Negative Phase sequence 46N

	0.8KA (0.2A)
	3.0 sec
>	1.2KA (0.3A)
	5.0 sec
max	2000 sec
min	0.5 sec
reset	5.0 sec

Earth Fault 51N

Char (SI/DT)	DT
Ie	0.35A (0.175A)
TMS	4.0 sec
TReset	0 sec
Ie>>	-
t>>	-

Voltage Balance 60

Vs >	10 V

Reverse Power 32R

Comp.	0 DEGREE
-P>	-0.8MW (1.0W)
T	4.0 sec
tDO	0 sec

Under Frequency 81U-1&2

F1	47.5 Hz
t1	0.1 sec
F2	47.1Hz
t2	0.1sec

Over Voltage 59

V>	28KV (140V)
t>	3 sec
V>>	32KV (160V)
t>>	0.5 sec

Field Failure 40

-Xa	115m Ohm (2.3 Ohm)
Xb	700m Ohm (14 Ohm)
t	0.1 sec
tdo	0 sec

Checked By: KC WONG
 DATE:24-4-2002

G. H. Liew Engineering (1990) Sdn. Bhd.

No. 25, Jalan 7/6, Seksyen 7, 46050 Petaling Jaya.

Tel: 03-79542675, 79548675, 79545270 Fax: 03-79548450

Web Address: <http://ghliew1990.com>

Generator Differential Relay test Report.

Job No : 3578/2002 - 14A
Client : TNB Generation Sdn. Bhd
Installation : SSAA Power Station Phase 3 - GT5, 525MW, KAPAR
Circuit : MULTI FUNCTION GEN. PROT. (PRIMARY) LGPG111-1

Relay Details :

Make	: GEC	Model	: LGPG11101S144LEB
Serial No	: 630491H	Aux Voltage	: 250Vdc
Code No	: 87G	Rated Current	: 5A

Relay Settings :

Description	Setting
Is1 Setting	1KA
K1 Setting	0%
Is2 Setting	24KA
K2 Setting	150%

Injection test :

Id	Element	Pick up (A)	Expected (A)
1	Ph A	0.264	0.25
2	Ph B	0.269	0.25
3	Ph C	0.259	0.25

Timing test.

Id	Element	Operating time (sec)	Expected (sec)
1	Ph A	0.028	Instant
2	Ph B	0.029	Instant
3	Ph C	0.027	Instant

Indication : OK
Output : R6
Remark : MAINTENANCE
Tested by : KC WONG
Date : 9-04-2002

Certified by,

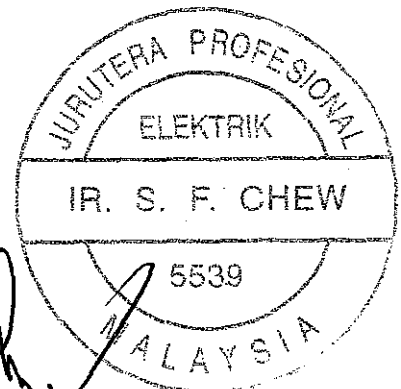
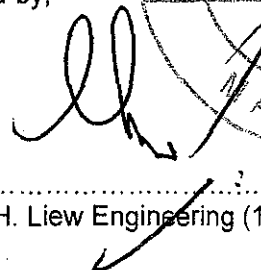

.....
G. H. Liew Engineering (1990) Sdn. Bhd.

G. H. Liew Engineering (1990) Sdn. Bhd.

No. 25, Jalan 7/6, Seksyen 7, 46050 Petaling Jaya.
Tel: 03-79542675, 79548675, 79545270 Fax: 03-79548450
Web Address: <http://ghliew1990.com>

Low Forward / Reverse Power Relay test Report.

Job No : 3578/2002 - 14B
Client : TNB Generation Sdn. Bhd
Installation : SSAA Power Station Phase 3 - GT5, 525MW, KAPAR
Circuit : MULTI FUNCTION GEN. PROT. (PRIMARY) LGPG111-1

Relay Details :

Make	: GEC	Model	: LGPG11101S144LEB
Serial No	: 630491H	Aux Voltage	: 250Vdc
Code No	: 32	Rated Current	: 5A

Relay Settings :

Id	Stage	Description	Setting Value 32R	Setting Value 32L
1	32	Power Setting	0.8 MW	0.8 MW
		Time Delay	4.0 sec	2.0 sec
		Time (Drop Off)	0 sec	0 sec

Action test :

Stage	Pickup (MW)	Drop-off (MW)	Expected (MW)
32R	0.797	0.620	0.8
32L	0.794	0.960	0.8

Timing test :

Stage	Operating time (sec)	Expected (sec)
32R	4.0	4.0
32L	2.09	2.0

Indication : OK
Output : R2, R13
Remark : MAINTENANCE
Tested by : KC WONG
Date : 9-04-2002

Certified by,

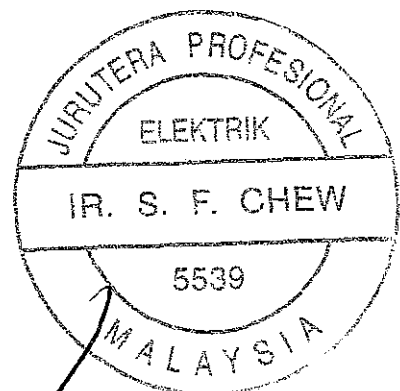
G. H. Liew Engineering (1990) Sdn. Bhd.

G. H. Liew Engineering (1990) Sdn. Bhd.

No. 25, Jalan 7/6, Seksyen 7, 46050 Petaling Jaya.
Tel: 03-79542675, 79548675, 79545270 Fax: 03-79548450
Web Address: <http://ghliew1990.com>

Field Failure Relay test Report.

Job No : 3578/2002 - 14C
Client : TNB Generation Sdn. Bhd
Installation : SSAA Power Station Phase 3 - GT5, 525MW, KAPAR
Circuit : MULTI FUNCTION GEN. PROT. (PRIMARY) LGPG111-1

Relay Details :

Type	: GEC	Model	: LGPG11101555MED
Serial No	: 630491H	Aux Voltage	: 250Vdc
Code No	: 40	Rated Current	: 5 Amp

Relay Settings :

No	Stage	Description	Setting Value
1	40	Xa	2.3Ω
		Xb	14Ω
		Time Delay	0.1secs
		Time (Drop-off)	0secs

Injection test on stage Xa + Xb :

Phase	Voltage (V)	Pick-up Current (A)	Calculate(Ω): $Xa+Xb=V / (I \times \sqrt{3})$	Expected (Ω)
R/Y/B	20	0.7	16.49	16.3

Injection test on stage Xa :

Phase	Voltage (V)	Pick up Current (A)	Calculate (Ω): $Xa=V / (I \times \sqrt{3})$	Expected (Ω)
R/Y/B	5	1.268	2.27	2.3

Timing test.

Stage	Operating time (sec)	Expected time (sec)
Xa +Xb	0.10	0.10
Xa	0.10	0.10

Location : OK
Output : R4
Remark : MAINTENANCE
Tested by : KC WONG
Date : 9-04-2002

Certified by,

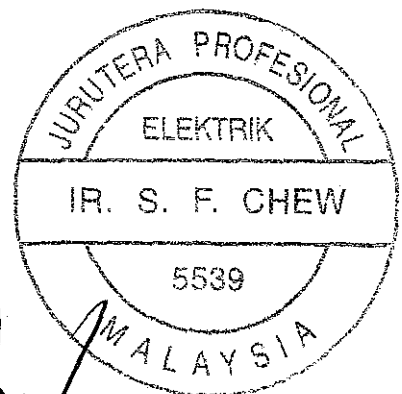
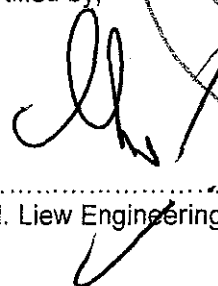

.....
G. H. Liew Engineering (1990) Sdn. Bhd.

G. H. Liew Engineering (1990) Sdn. Bhd.

No. 25, Jalan 7/6, Seksyen 7, 46050 Petaling Jaya.

Tel: 03-79542675, 79548675, 79545270 Fax: 03-79548450

Web Address: <http://ghliew1990.com>

Stator Earth Fault test Report.

Job No : 3578/2002 - 14D
Client : TNB Generation Sdn. Bhd
Installation : SSAA Power Station Phase 3 - GT5, 525MW, KAPAR
Circuit : MULTI FUNCTION GEN. PROT. (PRIMARY) LGPG111-1

Play Details :

Make	: GEC	Model	: LGPG 111 01555 MED
Serial No	: 630491H	Aux Voltage	: 250Vdc
CODE	: 51N		

Play Settings :

Description	Setting
$I_e >$	0.175A
TMS	4 sec
t RESET	0 sec
Characteristic	DT

Action Test :

Description	Pickup (A)	Drop Off (A)	Expected (A)
Current Injected	0.175	0.160	0.175

Timing Test:

Description	Operating Time (sec)	Expected (sec)
$10 \times I_e >$	4.01	4.0

Indication : OK
Output contact: R14
Remark : MAINTENANCE
Tested by : KC WONG
Date : 9-04-2002

Certified by

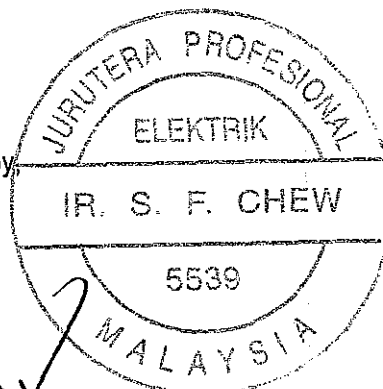

G. H. Liew Engineering (1990) Sdn. Bhd.

G. H. Liew Engineering (1990) Sdn. Bhd.

No. 25, Jalan 7/6, Seksyen 7, 46050 Petaling Jaya.
Tel: 03-79542675, 79548675, 79545270 Fax: 03-79548450
Web Address: <http://ghliew1990.com>

Neutral Displacement Relay Test Report.

Job No : 3578/2002 - 14E
Client : TNB Generation Sdn. Bhd
Installation : SSAA Power Station Phase 3 - GT5, 525MW, KAPAR
Circuit : MULTI FUNCTION GEN. PROT. (PRIMARY) LGPG111-1

Relay Details :

Make	: GEC	Model	: LGPG11101555MEB
Serial No	: 630491H	Aux Voltage	: 250Vdc
Code No	: 59N	Rated Current	: 5A

Relay Settings :

No	Stage	Description	Setting Value
1	59N-1	Ve> setting	17V
		Time Delay t1	4 sec
2	59N-2	Ve>>	17 V
		Time Delay t2	4 sec
		Reset Time	0 sec

Action Test :

Description	Pickup (V)	Drop Off (V)	Expected (V)
59N-1	17	16.07	17
59N-2	17	16.07	17

Timing Test:

Description	Operating Time (sec)	Expected (sec)
59N-1	4.0	4.0
59N-2	4.01	4.0

Indication : OK
Output : R11
Remark : MAINTENANCE
Tested by : KC WONG
Date : 9-04-2002

Certified by,

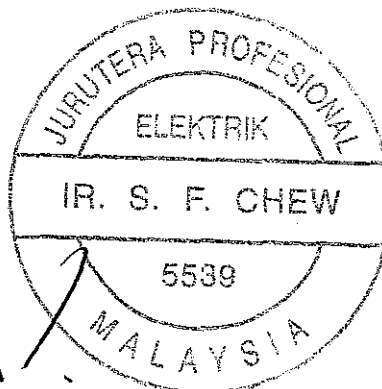

G. H. Liew Engineering (1990) Sdn. Bhd.

G. H. Liew Engineering (1990) Sdn. Bhd.

No. 25, Jalan 7/6, Seksyen 7, 46050 Petaling Jaya.
Tel: 03-79542675, 79548675, 79545270 Fax: 03-79548450
Web Address: <http://ghliew1990.com>

Voltage Dependent O/C Relay test Report.

Job No : 3578/2002 - 14F
Client : TNB Generation Sdn. Bhd.
Installation : SSAA Power Station Phase 3 - GT5, 525MW, KAPAR.
Circuit : MULTI FUNCTION GEN. PROT. (PRIMARY) LGPG111-1

Relay Details :

Type	: GEC	Model	: LGPG11101555MEB
Serial No	: 630491H	Aux Voltage	: 250Vdc
Rated Voltage	: 51V	Rated Current	: 5A

Relay Settings :

Description	Setting Value
VS 1	88V
VS 2	-
K	0.25
CHAR	DT
I >	6.5A
T	3 sec

Operation test :

Phase	Voltage Injected (V)	Expected Current (A)	Pick-up (A)	Drop-off(A)	Operating time at 2x I> (sec)
B, C	120	6.5	6.5	6.21	3
B, C	65	1.625	1.646	1.53	3
B, C	15	1.625	1.636	1.55	3

Relay Operation : OK
Relay Output : R3
Remarks : MAINTENANCE
Tested by : KC WONG
Date : 9-04-2002

Certified by

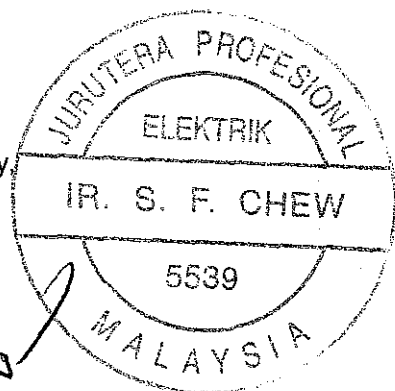
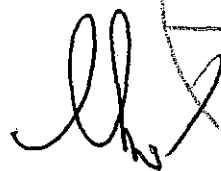

G. H. Liew Engineering (1990) Sdn. Bhd.

G. H. Liew Engineering (1990) Sdn. Bhd.

No. 25, Jalan 7/6, Seksyen 7, 46050 Petaling Jaya.
Tel: 03-79542675, 79548675, 79545270 Fax: 03-79548450
Web Address: <http://ghliew1990.com>

Negative Phase Sequence Relay test Report.

Job No : 3578/2002 - 14G
Client : TNB Generation Sdn. Bhd.
Installation : SSAA Power Station Phase 3 - GT5, 525MW, KAPAR.
Circuit : MULTI FUNCTION GEN. PROT. (PRIMARY) LGPG111-1

Relay Details :

Make	: GEC	Model	: LGPG11101555MEB
Serial No	: 630491H	Aux Voltage	: 250Vdc
Code No	: 46	Rated Current	: 5A

Relay Settings :

Stage	Description	Setting Value
46> Alarm	I2> setting	0.2A
	t>	3.0 sec
46>> trip	I2>> setting	0.3 A
	K3	5 sec
	T _{max}	2000 sec
	T _{min}	0.5 sec
	K _{reset}	5 sec

Action test :

Characteristic & operating time for 46> NPS Alarm

Phase Injected	Expected current (A)	Pick-up (A)	Drop-off(A)	Operating time (sec)
A-N	0.6	0.605	0.599	3.04

Characteristic & operating time for 46>> NPS trip

Phase Injected	Expected current (A)	Pick-up (A)	Expected time (sec)	Operating time (sec) at 4xI2>>
A-N	0.9	0.894	89.58	90.39

Indication : OK
Output : R8, R5
Remark : MAINTENANCE
Tested by : KC WONG
Date : 9-04-2002

Certified by,

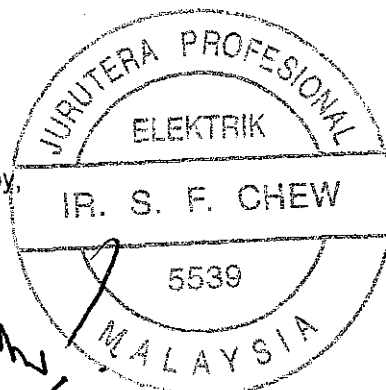

G. H. Liew Engineering (1990) Sdn. Bhd.

G. H. Liew Engineering (1990) Sdn. Bhd.

No. 25, Jalan 7/6, Seksyen 7, 46050 Petaling Jaya.
Tel: 03-79542675, 79548675, 79545270 Fax: 03-79548450
Web Address: <http://ghliew1990.com>

Under Frequency Relay test Report.

Job No : 3578/2002 - 14H
Client : TNB Generation Sdn. Bhd
Installation : SSAA Power Station Phase 3 - GT5, 525MW, KAPAR
Circuit : MULTI FUNCTION GEN. PROT. (PRIMARY) LGPG111-1

Relay Details :

Make	: GEC	Model	: LGPG11101555MEB
Serial No	: 630491H	Aux Voltage	: 250Vdc
Code No	: 81U.1 & 81U.2	Rated Current	: 5 A

Relay Settings :

Description	Setting
Frequency Setting, F1<	47.5 Hz
Time Delay, t1	0.1 sec
Frequency Setting, F2<	47.1 Hz
Time Delay, t2	0.1 sec

Action Test :

Description	Pickup (Hz)	Drop Off (Hz)	Expected (Hz)
81U.1	47.56	47.76	47.5
81U.2	47.13	47.19	47.1

Timing Test:

Description	Operating Time (sec)	Expected (sec)
81U.1	0.211	0.1
81U.2	0.17	0.1

Indication : OK
Output : R15, R12
Remark : MAINTENANCE
Tested by : KC WONG
Date : 9-04-2002

Certified by,

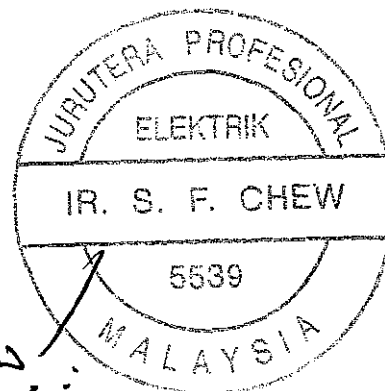

G. H. Liew Engineering (1990) Sdn. Bhd.

G. H. Liew Engineering (1990) Sdn. Bhd.

No. 25, Jalan 7/6, Seksyen 7, 46050 Petaling Jaya.
Tel: 03-79542675, 79548675, 79545270 Fax: 03-79548450
Web Address: <http://ghliew1990.com>

Over Voltage Relay test Report.

Job No : 3578/2002 - 141
Client : TNB Generation Sdn. Bhd
Installation : SSAA Power Station Phase 3 - GT5, 525MW, KAPAR
Circuit : MULTI FUNCTION GEN. PROT. (PRIMARY) LGPG111-1

Relay Details :

Make	: GEC	Model	: LGPG11101555MEB
Serial No	: 630491H	Aux Voltage	: 250Vdc
Code No	: 59.1 & 59.2	Rated Voltage	: 110Vac

Relay Settings :

No	Stage	Description	Setting Value
1	59.1	Voltage Setting	140 V
		Time Delay	3.0 sec
2	59.2	Voltage setting	160 V
		Time Delay	0.5 sec

Action Test :

Description	Pickup (V)	Drop Off (V)	Expected (V)
59.1	140.29	140.12	140
59.2	160.78	160.23	160

Timing Test:

Description	Operating Time (sec)	Expected (sec)
59.1	3.0	3.0
59.2	0.53	0.5

Indication : OK
Output : R7
Remark : MAINTENANCE
Tested by : KC WONG
Date : 09-04-2002

Certified by,

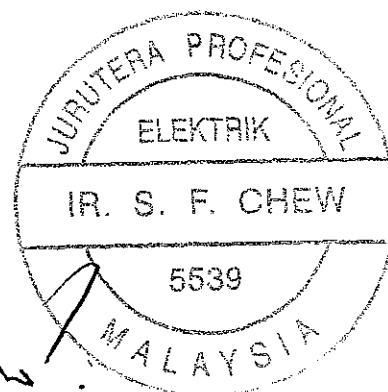
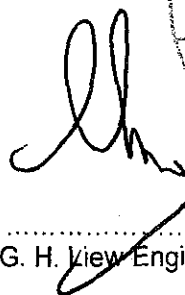

G. H. Liew Engineering (1990) Sdn. Bhd.

G. H. Liew Engineering (1990) Sdn. Bhd.

No. 25, Jalan 7/6, Seksyen 7, 46050 Petaling Jaya.
Tel: 03-79542675, 79548675, 79545270 Fax: 03-79548450
Web Address: <http://ghliew1990.com>

Voltage Balance Relay test Report. (code:60)

Job No : 3578/2002 - 14J
Client : TNB Generation Sdn. Bhd
Installation : SSAA Power Station Phase 3 - GT5, 525MW, KAPAR
Circuit : MULTI FUNCTION GEN. PROT. (PRIMARY) LGPG111-1

Relay Details :

Type	: GEC	Model	: LGPG 11101 555MED
Serial No	: 630491H	Rated Current	: 5A
Code	: 60	Rated Voltage	: 110Vac

Relay Settings :

Description	Setting
Over Voltage Setting	10 V

Secondary Injection Tests :

Phase	Pick-up Value (V)	Drop-off Value(V)	Remark	Expected (V)
V1(R-Y)	100.1	101.0	V2 =110V	100
V1(B-R)	100	101.0	V2 =110V	100
V2(R-Y)	100	101.1	V1 =110V	100
V2(B-R)	100.3	101.0	V1 =110V	100

Location : OK
Output Contact : R1
Remarks : MAINTENANCE
Tested by : KC WONG
Date : 09-04-2002

Certified by,

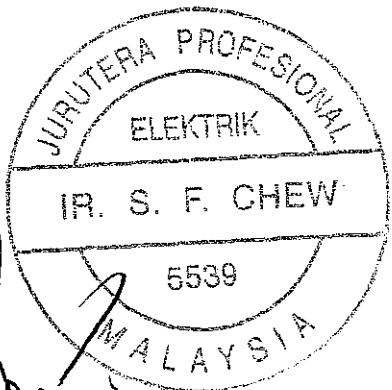
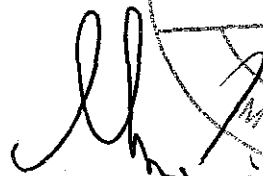

G. H. Liew Engineering (1990) Sdn. Bhd.

fault setting
and impedance a power
station setting
commissioning sets

abduljail@koparenergy.com.my

Transient response for transformer

CT saturation
involving CT

275KV SUBSTATION

ST → ± 10Y DC
low current (4-20mA)

- NOTES:
1. FOR DETAILED METERING AND RELAYING, SEE LINE OF WORK 275KV SUBSTATION. SEE ATTACHED DRAWINGS 20/04/2022.
 2. ALL PROTECTIVE RELAYING AND METERING DRAWING ARE LOCATED IN THE UNIT CONTROL ROOM, UNLESS NOTED OTHERWISE.
 3. EXCEPT FOR DEVICES BY 42 TODAY, ALL PROTECTIVE RELAYS AND METERING WILL BE FURNISHED UNDER E3-2001 CONTRACT.
 4. ISOLATED PHASE BUS DUCT RATINGS
HAP BUS: 20000A CONTINUOUS, 4250A S.C. FOR 3 SEC., 3500A PE
HAP BUS: 20000A CONTINUOUS, 4250A S.C. FOR 3 SEC., 652.5KA PE
- LEGEND:
- CONFIRMATION SYMBOL
 - HR MULTI RATIO CTS
 - DEVICES LOCATED IN DEEP
 - DEVICES LOCATED IN SHALLOW
 - DEVICES LOCATED ON TRANSFORMER

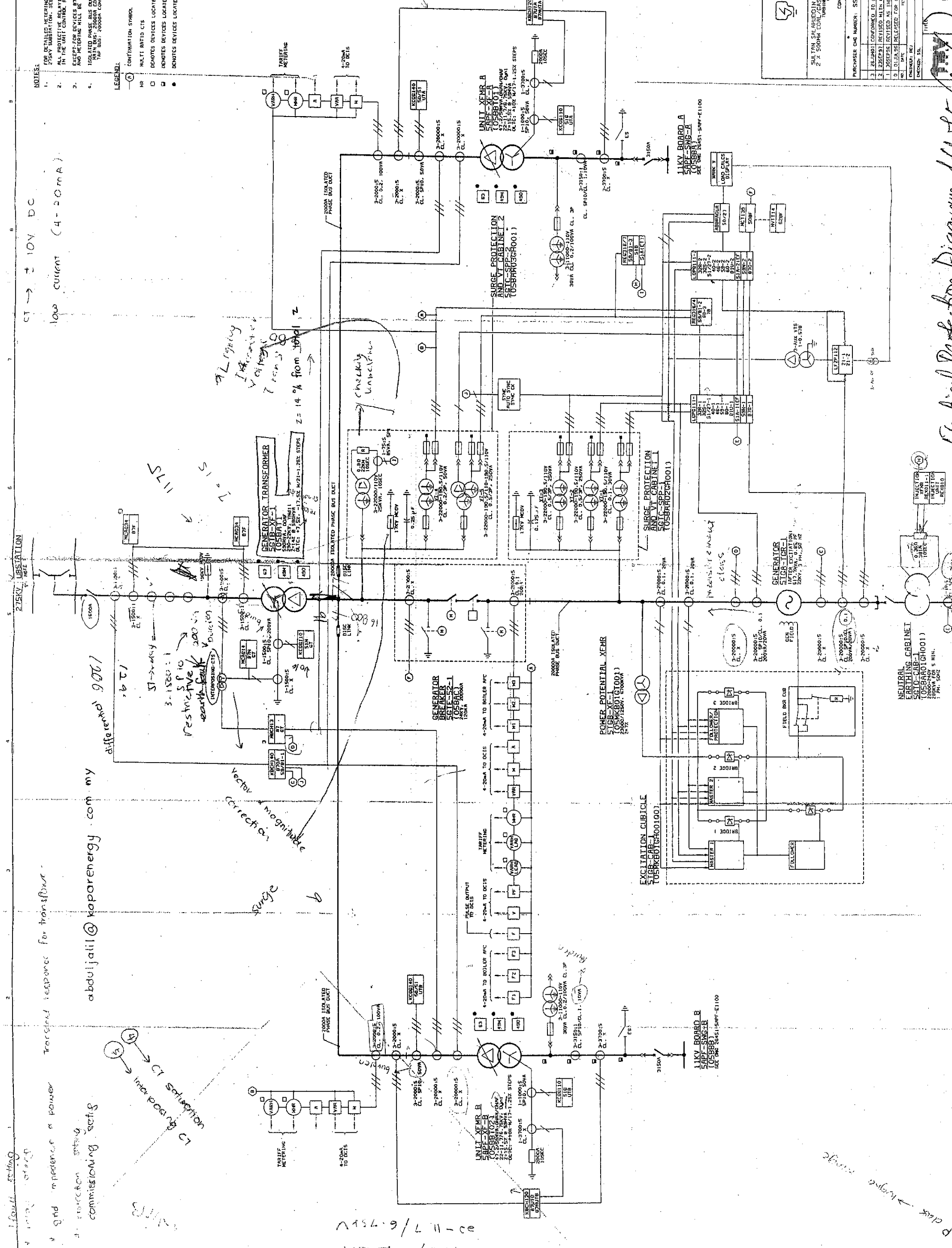

TENAGA NASIONAL BERHAD

SULTAN SAHABUDDIN REINVAUT ENGINEERING CONSULTANTS
2, 2A, SONGKA CONDUIT TOWER, 11200 PUTERI MANGROVE, MALACCA, MALAYSIA
CONTRACT NO. 102/05/11

CONTRACTOR: GE/CEFS (M)

PURCHASER CMC NUMBER: SS3-11-MKA-P-001-3

3. REVISIONS REFERENCED TO CONSTRUCTION RECORDS
2. ZONE(S) REVISED WITH A/C NUMBER(S)
1. ZONE(S) REVISED WITH A/C NUMBER(S)
0. DULAS RECEIVED FOR CONSTRUCTION

REVISIONS:

NO.	DATE	BY	REVISION
1			
2			
3			

REVISIONS: 01, 02, 03, 04, 05, 06, 07, 08, 09, 10, 11, 12, 13, 14, 15, 16, 17, 18, 19, 20, 21, 22, 23, 24, 25, 26, 27, 28, 29, 30, 31, 32, 33, 34, 35, 36, 37, 38, 39, 40, 41, 42, 43, 44, 45, 46, 47, 48, 49, 50, 51, 52, 53, 54, 55, 56, 57, 58, 59, 60, 61, 62, 63, 64, 65, 66, 67, 68, 69, 70, 71, 72, 73, 74, 75, 76, 77, 78, 79, 80, 81, 82, 83, 84, 85, 86, 87, 88, 89, 90, 91, 92, 93, 94, 95, 96, 97, 98, 99, 100, 101, 102, 103, 104, 105, 106, 107, 108, 109, 110, 111, 112, 113, 114, 115, 116, 117, 118, 119, 120, 121, 122, 123, 124, 125, 126, 127, 128, 129, 130, 131, 132, 133, 134, 135, 136, 137, 138, 139, 140, 141, 142, 143, 144, 145, 146, 147, 148, 149, 150, 151, 152, 153, 154, 155, 156, 157, 158, 159, 160, 161, 162, 163, 164, 165, 166, 167, 168, 169, 170, 171, 172, 173, 174, 175, 176, 177, 178, 179, 180, 181, 182, 183, 184, 185, 186, 187, 188, 189, 190, 191, 192, 193, 194, 195, 196, 197, 198, 199, 200, 201, 202, 203, 204, 205, 206, 207, 208, 209, 210, 211, 212, 213, 214, 215, 216, 217, 218, 219, 220, 221, 222, 223, 224, 225, 226, 227, 228, 229, 230, 231, 232, 233, 234, 235, 236, 237, 238, 239, 240, 241, 242, 243, 244, 245, 246, 247, 248, 249, 250, 251, 252, 253, 254, 255, 256, 257, 258, 259, 260, 261, 262, 263, 264, 265, 266, 267, 268, 269, 270, 271, 272, 273, 274, 275, 276, 277, 278, 279, 280, 281, 282, 283, 284, 285, 286, 287, 288, 289, 290, 291, 292, 293, 294, 295, 296, 297, 298, 299, 300, 301, 302, 303, 304, 305, 306, 307, 308, 309, 310, 311, 312, 313, 314, 315, 316, 317, 318, 319, 320, 321, 322, 323, 324, 325, 326, 327, 328, 329, 330, 331, 332, 333, 334, 335, 336, 337, 338, 339, 340, 341, 342, 343, 344, 345, 346, 347, 348, 349, 350, 351, 352, 353, 354, 355, 356, 357, 358, 359, 360, 361, 362, 363, 364, 365, 366, 367, 368, 369, 370, 371, 372, 373, 374, 375, 376, 377, 378, 379, 380, 381, 382, 383, 384, 385, 386, 387, 388, 389, 390, 391, 392, 393, 394, 395, 396, 397, 398, 399, 400, 401, 402, 403, 404, 405, 406, 407, 408, 409, 410, 411, 412, 413, 414, 415, 416, 417, 418, 419, 420, 421, 422, 423, 424, 425, 426, 427, 428, 429, 430, 431, 432, 433, 434, 435, 436, 437, 438, 439, 440, 441, 442, 443, 444, 445, 446, 447, 448, 449, 450, 451, 452, 453, 454, 455, 456, 457, 458, 459, 460, 461, 462, 463, 464, 465, 466, 467, 468, 469, 470, 471, 472, 473, 474, 475, 476, 477, 478, 479, 480, 481, 482, 483, 484, 485, 486, 487, 488, 489, 490, 491, 492, 493, 494, 495, 496, 497, 498, 499, 500, 501, 502, 503, 504, 505, 506, 507, 508, 509, 510, 511, 512, 513, 514, 515, 516, 517, 518, 519, 520, 521, 522, 523, 524, 525, 526, 527, 528, 529, 530, 531, 532, 533, 534, 535, 536, 537, 538, 539, 540, 541, 542, 543, 544, 545, 546, 547, 548, 549, 550, 551, 552, 553, 554, 555, 556, 557, 558, 559, 560, 561, 562, 563, 564, 565, 566, 567, 568, 569, 570, 571, 572, 573, 574, 575, 576, 577, 578, 579, 580, 581, 582, 583, 584, 585, 586, 587, 588, 589, 590, 591, 592, 593, 594, 595, 596, 597, 598, 599, 600, 601, 602, 603, 604, 605, 606, 607, 608, 609, 610, 611, 612, 613, 614, 615, 616, 617, 618, 619, 620, 621, 622, 623, 624, 625, 626, 627, 628, 629, 630, 631, 632, 633, 634, 635, 636, 637, 638, 639, 640, 641, 642, 643, 644, 645, 646, 647, 648, 649, 650, 651, 652, 653, 654, 655, 656, 657, 658, 659, 660, 661, 662, 663, 664, 665, 666, 667, 668, 669, 670, 671, 672, 673, 674, 675, 676, 677, 678, 679, 680, 681, 682, 683, 684, 685, 686, 687, 688, 689, 690, 691, 692, 693, 694, 695, 696, 697, 698, 699, 700, 701, 702, 703, 704, 705, 706, 707, 708, 709, 710, 711, 712, 713, 714, 715, 716, 717, 718, 719, 720, 721, 722, 723, 724, 725, 726, 727, 728, 729, 730, 731, 732, 733, 734, 735, 736, 737, 738, 739, 740, 741, 742, 743, 744, 745, 746, 747, 748, 749, 750, 751, 752, 753, 754, 755, 756, 757, 758, 759, 760, 761, 762, 763, 764, 765, 766, 767, 768, 769, 770, 771, 772, 773, 774, 775, 776, 777, 778, 779, 780, 781, 782, 783, 784, 785, 786, 787, 788, 789, 790, 791, 792, 793, 794, 795, 796, 797, 798, 799, 800, 801, 802, 803, 804, 805, 806, 807, 808, 809, 810, 811, 812, 813, 814, 815, 816, 817, 818, 819, 820, 821, 822, 823, 824, 825, 826, 827, 828, 829, 830, 831, 832, 833, 834, 835, 836, 837, 838, 839, 840, 841, 842, 843, 844, 845, 846, 847, 848, 849, 850, 851, 852, 853, 854, 855, 856, 857, 858, 859, 860, 861, 862, 863, 864, 865, 866, 867, 868, 869, 870, 871, 872, 873, 874, 875, 876, 877, 878, 879, 880, 881, 882, 883, 884, 885, 886, 887, 888, 889, 890, 891, 892, 893, 894, 895, 896, 897, 898, 899, 900, 901, 902, 903, 904, 905, 906, 907, 908, 909, 910, 911, 912, 913, 914, 915, 916, 917, 918, 919, 920, 921, 922, 923, 924, 925, 926, 927, 928, 929, 930, 931, 932, 933, 934, 935, 936, 937, 938, 939, 940, 941, 942, 943, 944, 945, 946, 947, 948, 949, 950, 951, 952, 953, 954, 955, 956, 957, 958, 959, 960, 961, 962, 963, 964, 965, 966, 967, 968, 969, 970, 971, 972, 973, 974, 975, 976, 977, 978, 979, 980, 981, 982, 983, 984, 985, 986, 987, 988, 989, 990, 991, 992, 993, 994, 995, 996, 997, 998, 999, 1000

ONE-LINE DIAGRAM
UNIT 5 METERING AND RELAYING