

**Design, Fabricate and Test of an Injector Driver for
Automotive Direct Injector**

by

Taufiqurrahman bin Mohd Yunus

Dissertation submitted in partial fulfilment of
the requirements for the
Bachelor of Engineering (Hons)
(Electrical & Electronics Engineering)

DECEMBER 2009

**Universiti Teknologi PETRONAS
Bandar Seri Iskandar
31750 Tronoh
Perak Darul Ridzuan**

CERTIFICATION OF APPROVAL

Design, Fabricate and Test of an Injector Driver for Automotive Direct Injector

By

Taufiqurrahman Bin Mohd Yunus

A project dissertation submitted to the
Electrical and Electronics Engineering Programme
Universiti Teknologi PETRONAS
in partial fulfilment of the requirement for the
BACHELOR OF ENGINEERING (Hons)
(ELECTRICAL AND ELECTRONICS ENGINEERING)

Approved by,

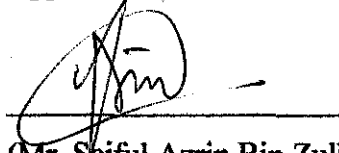

(Mr. Saiful Azrin Bin Zulkifli)

Main Supervisor

UNIVERSITI TEKNOLOGI PETRONAS

TRONOH, PERAK

December 2009

CERTIFICATION OF ORIGINALITY

This is to certify that I am responsible for the work submitted in this project, that the original work is my own except as specified in the references and acknowledgements, and that the original work contained herein have not been undertaken or done by unspecified sources or persons.



TAUFIQURRAHMAN BIN MOHD YUNUS

ABSTRACT

The objective of this project is to design and test a suitable driver circuit to meet current control objectives. Injector drivers for automotive engines require peak-and-hold current control for operation. For this project, the designed circuits need to be tested and compared to an injector driver that is available in the market. Implementation of the driver circuit will be done on PCB using an injector driver chip, PCB maker and schematic capture software. At the end of this project, the fabricated circuit will be tested with an actual automotive injector. Analog electronics and microelectronics knowledge will be applied for designing the circuit and to analyze the acquired data. As a conclusion, this project is to design, fabricate and test an injector driver that can meet current control objectives: peak-and-hold current.

ACKNOWLEDGMENT

First of all, thank God for this opportunity and seeing me through some truly difficult times especially through the period of this FYP 1 and FYP 2. My highest gratitude goes to all those who helped me towards the completion of this Final Year Project either directly or indirectly. First up to my supervisor, Mr. Saiful Azrin, an Electrical and Electronics lecturer, thanks for all the never-ending support and trust given to me in order to carry out the project given. Besides, I appreciate all your comments and remarks given to me with regards to my project as this is crucial for me to take note when doing my FYP in the future. My further gratitude is to all the lecturers, technicians and related staff who have assisted me in completing this project. Last but not least, not to forget my family and friends who gave me the supports towards the completion this course and project. Thank you very much for the fully hearted support.

TABLE OF CONTENT

ABSTRACT	iv
ACKNOWLEDGMENT	v
LIST OF FIGURES	viii
CHAPTER 1 INTRODUCTION	1
1.1 Background of Study	1
1.2 Problem Statement	2
1.3 Objective and Scope of Study	2
CHAPTER 2 LITERATURE REVIEW	3
2.1 Type of Fuel Injector.....	3
2.1.1 <i>Peak-and-Hold Injector (Low impedance: 1.7-3.0 ohm)</i>	3
2.1.2 <i>Saturated Circuit Injector (High impedance: 10-16 ohm)</i>	4
2.1.3 <i>Purpose and Function</i>	4
2.1.4 <i>Method of Measurement</i>	5
2.1.5 <i>Power Rating of Fuel Injector</i>	5
2.2 Peak-and-Hold Injector Driver.....	5
2.2.1 <i>Injectors (L_I)</i>	6
2.2.2 <i>Timer (R_T and C_T)</i>	6
2.2.3 <i>Compensation (C_C)</i>	7
2.2.4 <i>Zener Diode (Z_I)</i>	7
2.3 Peak-and-Hold Injector Waveforms	8

CHAPTER 3 METHODOLOGY	10
3.1 Procedure Identification.....	10
3.2 Tools and Equipments Required	11
3.2.1 <i>Eagle Layout Editor 5.1.0</i>	11
3.2.2 <i>LabVIEW 7.1</i>	11
3.2.3 <i>Power Supply Unit</i>	11
3.2.4 <i>Function Generator</i>	11
3.2.5 <i>Orbital Low Impedance Direct Injector</i>	12
3.2.6 <i>Orbital Low Side Injector Driver</i>	12
3.2.7 <i>Injector Driver (LM1949 IC)</i>	12
3.3 Research Methodology.....	13
3.3.1 <i>Software and Hardware Manual</i>	13
3.3.2 <i>Books</i>	13
3.3.3 <i>Internet</i>	13
3.4 Project Milestone	14
CHAPTER 4 RESULTS AND DISCUSSION	15
4.1 System Design.....	15
4.2 Fabrication and Testing.....	17
4.3 Data Analysis	20
CHAPTER 5 CONCLUSIONS AND RECOMMENDATIONS	23
5.1 Conclusions.....	23
5.2 Recommendations	23
REFERENCES.....	24
APPENDICES	25
APPENDIX A: DIRECT INJECTOR SPECIFICATION	26

LIST OF FIGURES

Figure 1: Different length of fuel injector.....	4
Figure 2: Typical application and test circuit.....	5
Figure 3: Zener current waveform	7
Figure 4: Typical circuit waveforms	8
Figure 5: Closed up peak and hold waveform	9
Figure 6: Project Gantt chart	14
Figure 7: Equipments setup.....	15
Figure 8: Circuit connection	16
Figure 9: PCB schematic.....	17
Figure 10: PCB layout.....	17
Figure 11: Complete circuit	18
Figure 12: Test on actual direct injector	18
Figure 13: Test using Orbital Injector Driver	19
Figure 14: Injector current for 50ms pulse duration	20
Figure 15: Injector current for 30ms pulse duration	21
Figure 16: Injector current for 10ms pulse duration	21
Figure 17: Close up for 10ms pulse duration	22

CHAPTER 1

INTRODUCTION

1.1 Background of Study

“Fuel driver injection is a quick, responsive, reliable way to meter the right amount of fuel and spark for a given volume of air to an engine” [4]. Early automotive engines found on 1983-84 Celica’s use an analog system. For a given volume of air, an appropriate amount of fuel is metered into the engine by the injectors. This signal is amplified by input from other sensors, but for analog system, resistance is used to control its operation.

Direct fuel injectors are just simple solenoid devices that allow pressurized fuel to be squirted into the engine in a fine spray for a predetermined period of time [4]. An injector’s size is measured in how much volume of fuel it can flow in a given period of time. United States domestic injectors are usually measured in pounds per hour (lbs/hr), while injectors for import engines are usually measured in cubic centimeters per minute (cc/min) [4]. Injectors come in two types which are low impedance (typically less than 3 ohms) and high impedance (typically more than 12 ohms) known respectively as “peak-and-hold” and “saturated” injector.

The National Semiconductor LM1949 injector controller chip gives great control on fuel injector drive circuitry in modern automotive systems [1]. The chip is designed to control an external power NPN Darlington transistor that drives the high current through the injector solenoid.

1.2 Problem Statement

Peak-and-hold injectors typically have between 1 to 3 ohms of resistance in their coil windings. This would mean quite a lot of current for an injector winding to handle for long periods of time. When the injector reaches peak current, the driver switches to a hold state. This state reduces the current flow in the injector to 1 ampere (the amount of holding current is dependent on the driver configuration of the particular application). Since it takes less current to hold something open, after it has been opened, the current is then reduced. This lower current will reduce the heat buildup. It also allows for a quicker closing time, because the lower current has resulted in a weaker magnetic field to overcome when closing [2].

The current required to open a solenoid is several times greater than the current necessary merely to hold it open, therefore the injector driver by directly sensing the actual solenoid current, initially saturates the driver until the 'peak' injector current is 4 times that of the idle or 'hold' current. This guarantees opening of the injector [3].

1.3 Objective and Scope of Study

The objective of this project is to design and test suitable peak-and-hold circuit to meet the required current control. The circuit also will be used for comparison with another injector driver available at UTP laboratory. It includes analysis on driver circuit itself and the fabrication of the circuit using PCB. In order to achieve this objective, a few research and circuit design process need to be carried out by collecting all technical details and perform certain test using circuit simulator. The best circuit will be implemented on PCB and test will be performed on actual automotive direct injector.

CHAPTER 2

LITERATURE REVIEW

2.1 Type of Fuel Injector

Injector impedance is the electrical resistance exists in the solenoid windings. These are usually grouped in two categories which are low impedance and high impedance. There also have different length of fuel injector as shown in *Figure 1*.

2.1.1 Peak-and-Hold Injector (Low impedance: 1.7-3.0 ohm)

Peak and hold injectors may also be called current sensing or current limiting driver. These types of injectors are more expensive and complex than saturated circuit drivers, and are not generally used with domestic production ECUs. Besides, these injectors primarily used in aftermarket high performance systems. It was shown that “most high flow injectors are low resistance (2-5 ohms) and use a peak and hold driver to activate them” [8]. The “peak” current is the amount required to quickly open the injector, and then the lower “hold” current rating is used to keep it open for as long as the input signal. These require the extra kick from the higher current to keep the opening and closing time of the injector stable at the higher fuel flow rate. With this type of driver, 12 volts is still delivered to the injector, but due to its low resistance, the current in the driver circuit is high. This is substantial current flow and a high impedance injector cannot handle it. The drivers usually come in two values which are 4 amp peak/1 amp hold, and 2 amp peak/0.5 amp hold. Even though 6 amps may be available to operate the injector, the maximum it is allowed to reach is 2 or 4 amps, depending on the driver’s current limit.

2.1.2 Saturated Circuit Injector (High impedance: 10-16 ohm)

Saturated circuit injectors mostly used in domestic production of Electronic Fuel Injection (EFI) system. These injectors are very inexpensive, simple, and reliable. This type of driver works by supplying 12 volts to the injectors and the ECU turns it on and off to establish a fuel injector pulse. Generally, if an injector has a high resistance specification (12-16 ohms) the ECU uses a 12 volt saturated circuit driver to control it. This means that “the current flow in the driver and injector circuit stays low keeping the components nice and cool for long life” [8]. The disadvantage of a saturated circuit driver is that it has a slower response time (and closing time) compared to peak and hold type. This slower time can decrease the usable operating range of the injector energized by this driver. An injector operating on a saturated circuit driver typically has a reaction time of 2 milliseconds while a peak and hold driver typically responds in 1.5ms.

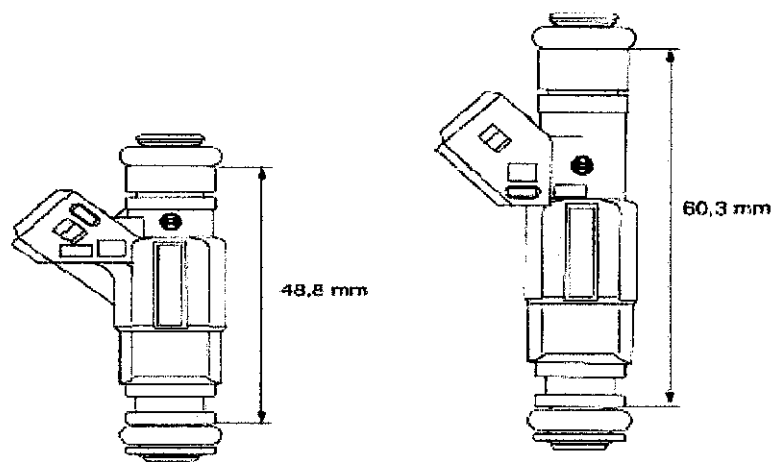

Figure 1: Different length of fuel injector [7]

2.1.3 Purpose and Function

The purpose and function of fuel injectors is to “perform the accurate metering and atomization of fuel” [7]. These electro-mechanical valves react in milliseconds to open and close which gives the ECU optimal control over fuel flow to the engine.

2.1.4 Method of Measurement

Fuel flow specifications are given in grams per minute (g/min), as this is an internationally accepted standard at vehicle manufacturing level. As vehicle development engineer deal with the weight or mass of air inducted by an engine not its expected power rating, the weight of fuel that an injector can provide is the pivotal measurement.

2.1.5 Power Rating of Fuel Injector

It has become an aftermarket performance industry practice to “rate fuel injectors in relation to expected engine power outputs, mainly horsepower” [7]. As this method of measurement has many issues in relation to various calculation methods, accuracy, individual interpretation and overall relevance, supplier of fuel injectors does not subscribe to this specification method. There are many design requirements taken into account when undertaking the design and manufacture of a fuel injector to suit a particular application.

2.2 Peak-and-Hold Injector Driver

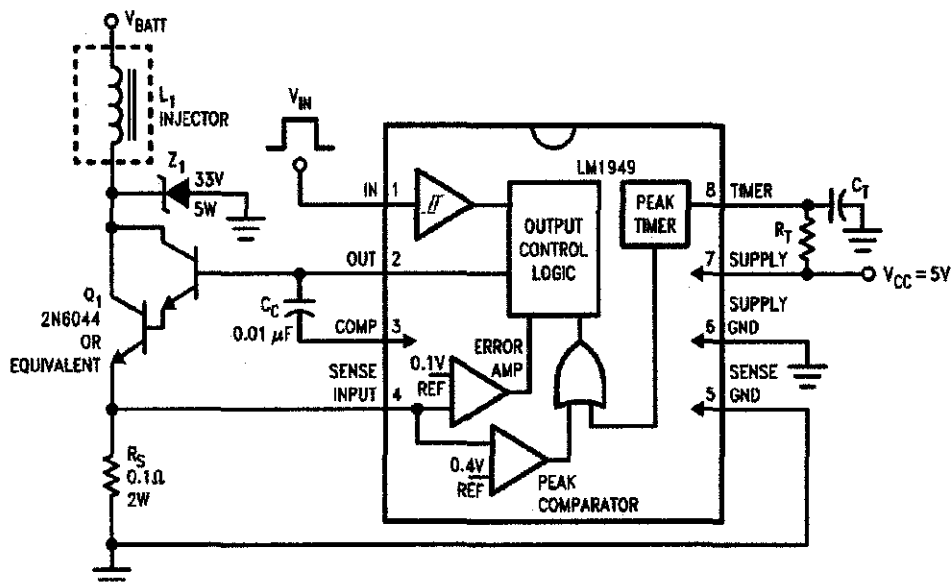

506201

Figure 2: Typical application and test circuit [1]

Figure 2 shows the design of full connection using LM1949 injector drive controller chip. This circuit is one of many different variations of peak and hold circuit but still have the same function. From the start of an injector pulse, the circuit works about the same. The analog circuit relays the logic 'high' signal to the base of the transistor, which fully saturates it, causing the collector too short to the emitter. One difference in this circuit is the 0.1 ohm resistor in series with the emitter. This voltage is proportional to the current through the injector and is monitored by the analog circuit. From this point on, a much smaller amount of current is needed to hold the injector open.

The injector controller chip was designed to be used in conjunction with an external controller. The LM1949 can get the input from PC-based controller or function generator. This input signal, in the form of square wave with a variable duty cycle or frequency is applied to pin 1 [1].

2.2.1 Injectors (L_I)

Injector in *Figure 2* can usually be modeled by a simple RL circuit. In actual operation, the inductance of the injector depends on whether it is open or closed. This characteristic can be used to determine the current required to open a certain type of fuel injector [1]. For the value of sense input voltage at 130 mV, the current necessary to open that particular injector is approximately 1.3A.

2.2.2 Timer (R_T and C_T)

R_T and C_T connected between pin 7 and 8 is used to limit the power dissipated by the injector under certain condition. Value of resistor and capacitor will set the timer period to just less than 5ms. This timer is used during periods where the current through the injector doesn't reach 386mV peak threshold voltage. This can happen during cranking periods where the battery voltage is too low to get 3.86A through the injector coil. When one time cycle is reach (4.6ms) the controller drops into hold mode. The timer is reset at the end of each input pulses. If the timer function is not used, it can be disabled by grounding the TIMER pin (Pin 8).

2.2.3 Compensation (C_C)

A 0.01 μ F compensation capacitor was installed between pin 2 and 3 as recommended to reduce the oscillation and maintain stability during hold state. In designing process, the value or type of compensation capacitor is not critical. Circuit on *Figure 2* can have value from 100pF to 0.1 μ F for the compensation capacitor.

2.2.4 Zener Diode (Z_1)

The 33V/5W zener diode was used to clamp the maximum positive voltage excursions to 33V or rated zener voltage. This diode gives the energy stored in the injector coil a current path for inductive kickback. If it wasn't for stray leakage, this kickback voltage would go to infinity and destroying as much component as it could. In *Figure 2*, the zener diode is connected before Q_1 to make sure the system peak current less than the guaranteed minimum breakdown of Q_1 . The second purpose of Z_1 is to provide system transient protection. Automotive systems are susceptible to voltage transients on the power supply. Although the duration is short, Q_1 could have permanent damage unless absorbed by the injector and Z_1 . *Figure 3* below shows the zener current is conducting majority of injector current during peak-to-hold transition.

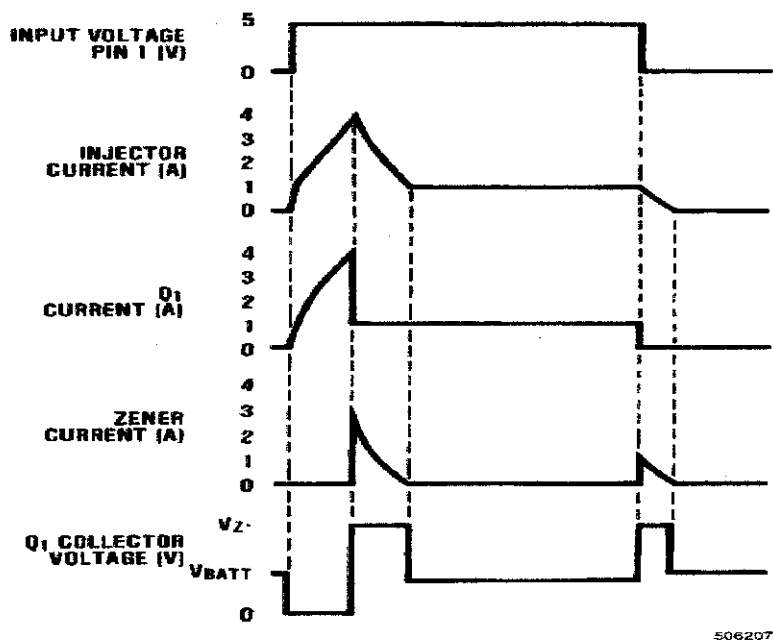

Figure 3: Zener current waveform [1]

2.3 Peak-and-Hold Injector Waveforms

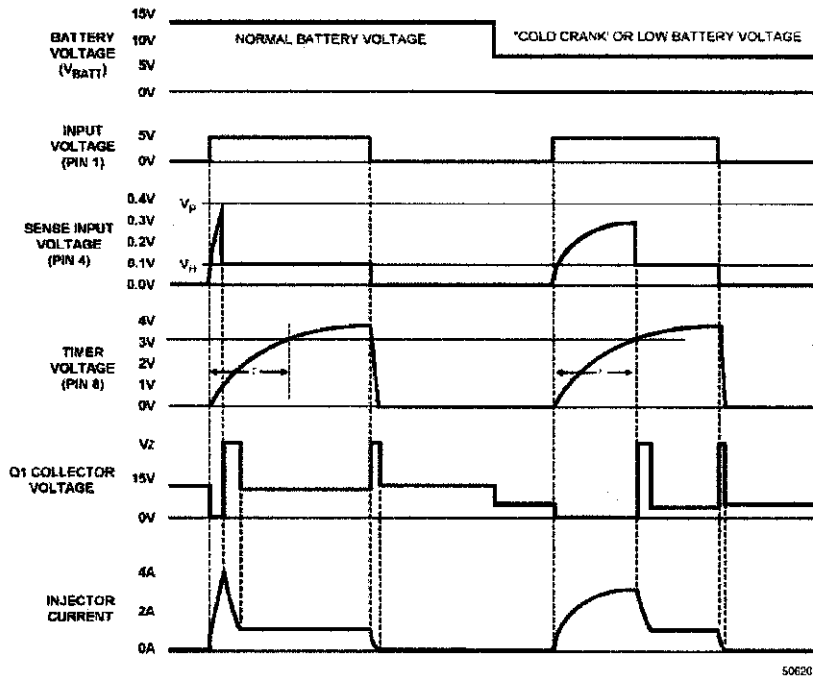

Figure 4: Typical circuit waveforms [1]

Figure 4 shows the typical waveform under normal battery voltage and low battery voltage. The injector peak and hold current can be determined by the value of sense resistor, R_s . With the sense resistor set to 0.1Ω , it makes thing simple to calculate. 100mV voltage drops across R_s equals 1A through the injector. The LM1949 trips into hold mode when the voltage across the sense resistor reaches 386mV and gives 3.86A through injector. During hold mode, the controller acts like an op-amp holding the voltage across R_s to 94mV . The injector current will remain at hold level for the duration of the input signal at pin 1 [1].

The purpose to have peak current 4 times than the hold current is to overcome kinetic and constriction forces when working with solenoids. Power dissipated in solenoids and transistor also can be reduced by holding injector current at $\frac{1}{4}$ of the peak current. 4A peak current was chosen to make sure the injector operation over the life and temperature range of the system [1]. By choosing 0.1Ω of R_s value, it will give 3.86A peak and 0.94A hold current which is closed to the recommended value.

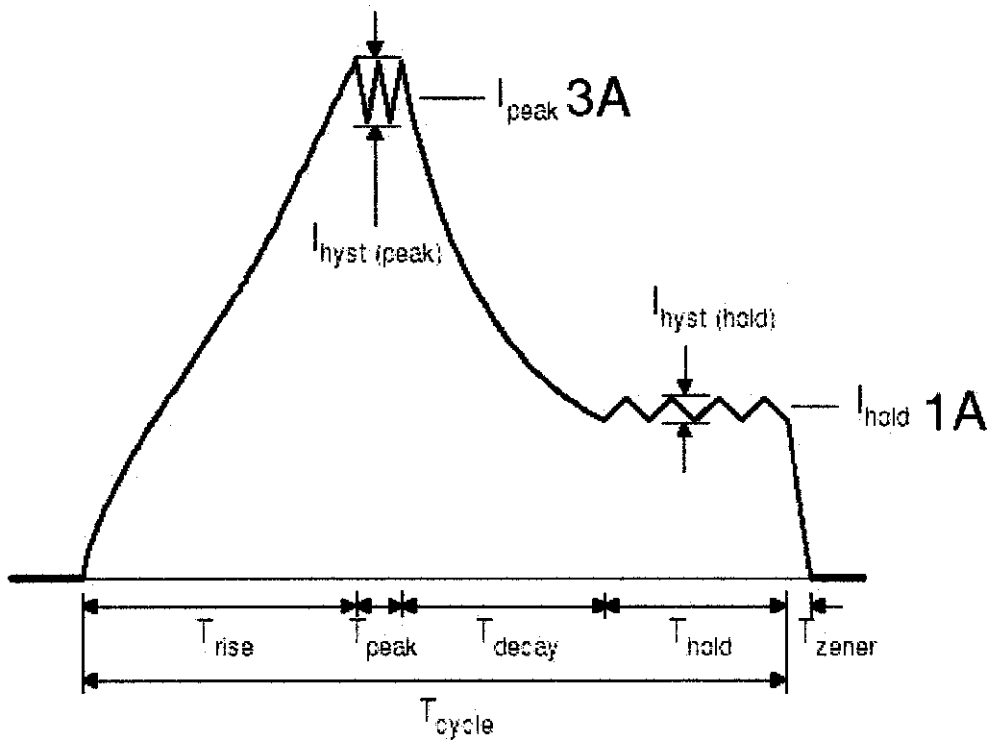

Figure 5: Closed up peak and hold waveform
(Source image: Orbital documentation)

Figure 5 shows the closed up view of peak and hold current for direct injector (reproduced from Orbital). This type of injector requires 3A to open the solenoid and 1A to keep the solenoid open while minimizing power dissipated. The waveform show corresponding time taken for rise, peak, decay and hold state. Time cycle is the time taken for one input pulse to set and reset. This time can be adjusted depend on the input signal generated at pin 1 of the LM1949. Peak time is fixed and cannot be changed unless there are modifications were made to the circuit. Hold time is always depending on the input signal come from PC-based controller or function generator.

There have some oscillation during the hold state due to the Darlington power device used. That's why there has compensation part connected at pin 2 and 3 of the circuit to reduce the oscillation and provides stability.

CHAPTER 3

METHODOLOGY

3.1 Procedure Identification

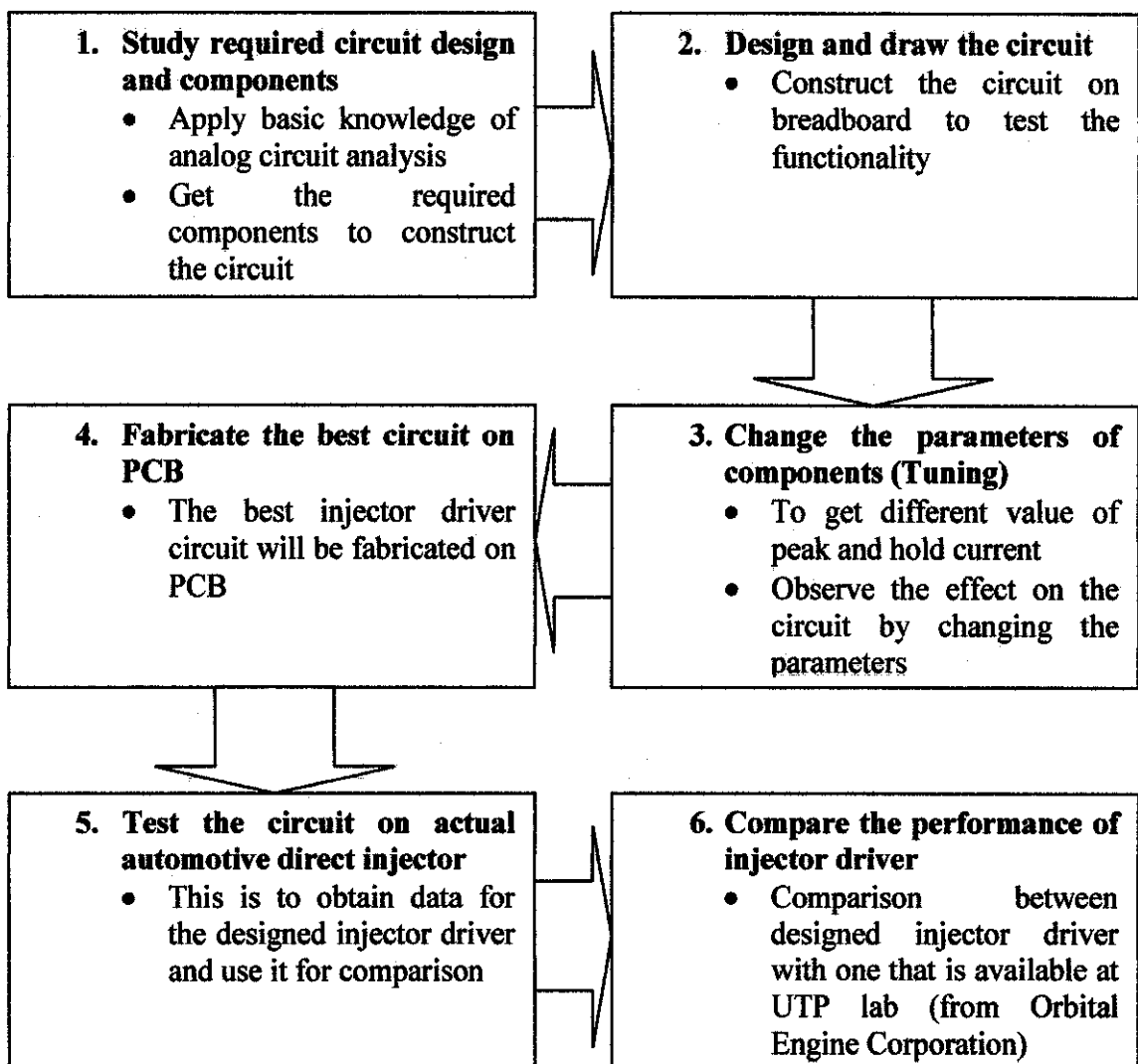

3.2 Tools and Equipments Required

Software

3.2.1 Eagle Layout Editor 5.1.0

This software was used to draw the schematic diagram and the layout for the PCB board before it will be fabricated on the PCB. Eagle Layout Editor 5.0.1 was chosen instead of other software because only this software was compatible with PCB workstation at the PCB lab.

3.2.2 LabVIEW 7.1

LabVIEW (Laboratory Virtual Instrumentation Engineering Workbench) is a platform and development environment for a visual programming language. LabVIEW is commonly used for data acquisition, instrument control and industrial automation [6]. For this project, LabVIEW was used to acquire data after the reading was obtained by using transducer.

Hardware

3.2.3 Power Supply Unit

The injector driver circuit requires two (2) power supplies. One is for the injector (solenoid) which needs 12V/14V supply and another one is for the LM1949 IC. The IC requires 3V-5.5V of voltage supply to operate normally.

3.2.4 Function Generator

A function generator is a piece of electronic test equipment or software used to generate electrical waveforms. These waveforms can be either repetitive, or single-shot in which case some kind of triggering source is required (internal or external). The function generator is required to generate input pulses for the injector driver.

3.3 Research Methodology

3.3.1 Software and Hardware Manual

This is more on understanding of the system and device itself with closer view. The manuals given during the installation of the software and hardware are not enough for giving more understanding on the device itself. The manuals give the basic concept and steps on how to handle the devices. The component datasheet give some useful information such as the parameter value needed to construct the circuit.

3.3.2 Books

To enquire more knowledge and understanding of the component and circuit used, research on books is very useful. Much information such as the typical values and specification can be identified by using this research method. The verification and understanding of certain criteria can be made assists by the books and past journals.

3.3.3 Internet

Internet is one of the easiest methods to find information, knowledge and do researches. Much information obtained from this research method. Internet can help us access into the unlimited condition of requiring knowledge.

3.4 Project Milestone

No.	Detail/ Week	1	2	3	4	5	6	7	8	9	10	11	12	13	14
1	Project work continues	Process	Process	Process	Process	Process	Process	Process							
2	Submission of Progress Report 2								Milestone						
3	Seminar (compulsory)									Process	Process	Process			
4	Project work continue								Process	Process	Process	Process			
5	Poster Exhibition										Milestone				
6	Submission of Dissertation (Soft bound)												Milestone		
7	Oral Presentation													Milestone	
8	Submission of Project Dissertation (Hard														Milestone

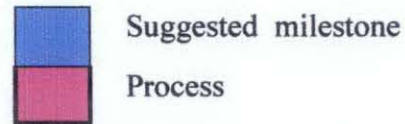

Figure 6: Project Gantt chart

CHAPTER 4

RESULTS AND DISCUSSION

4.1 System Design

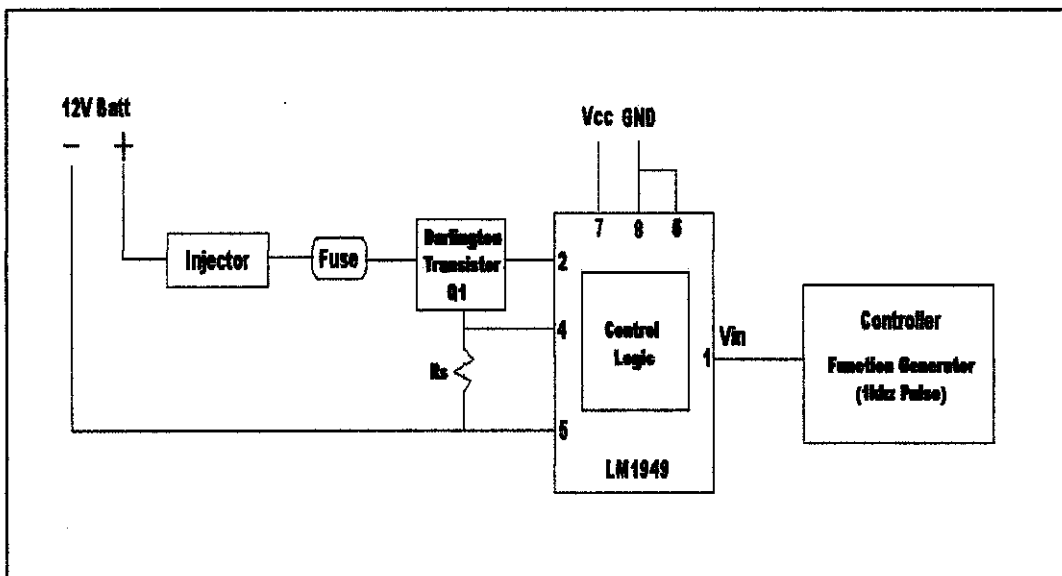

Figure 7: Equipments setup

Figure 7 shows the setup of the injector with connection of other peripheral or component such as fuse and controller. 8A fuse was chosen and connected in series with Darlington transistor to protect it from blow due to the overrated of current flow. The input of the LM1949 IC is come from external controller which is the function generator. This controller is used to generate required input pulses to the IC. By using function generator, variations of inputs pulses can be generated by manipulate the frequency. In this case the square wave pulse was used.

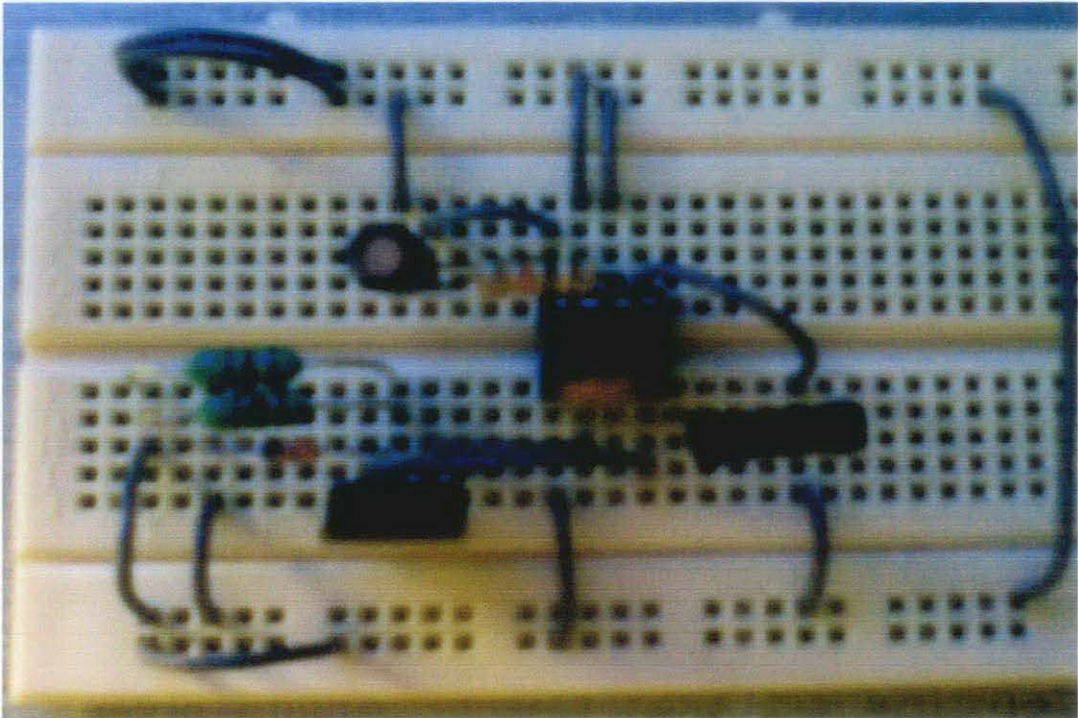

Figure 8: Circuit connection

The circuit on *Figure 8* shows the initial design of the injector driver circuit connection on breadboard. During this stage, the circuit cannot be tested with the direct injector because that injector is high impedance type. This circuit is design for use with low impedance injector only. If using a high impedance fuel injector, this circuit cannot perform its peak and hold current control function. Thus this project is stuck until suitable low impedance fuel injector is found.

Eventually there have one set of low impedance direct injector and injector driver kit available at UTP laboratory, so the test to obtain data for benchmarking has been done. The result is use for comparison between these two injector drivers.

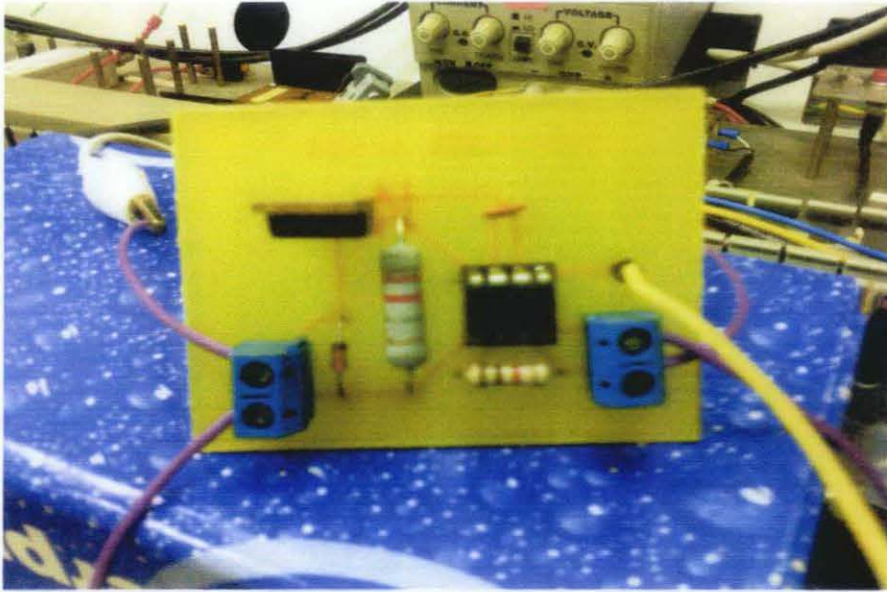

Figure 11: Complete circuit

Figure 9 and *Figure 10* show the PCB schematic diagram and layout of the injector driver circuit. The schematic was drawn using *Eagle* software. By using this schematic diagram, the PCB layout can be drawn using the same software. *Figure 11* shows the complete connection of component and wiring on PCB.



Figure 12: Test on actual direct injector

Figure 12 shows the setup for testing the designed circuit on actual automotive direct injector. This circuit is connected with external peripheral such as power supply, oscilloscope and PC-based controller for data acquisition and generating input.

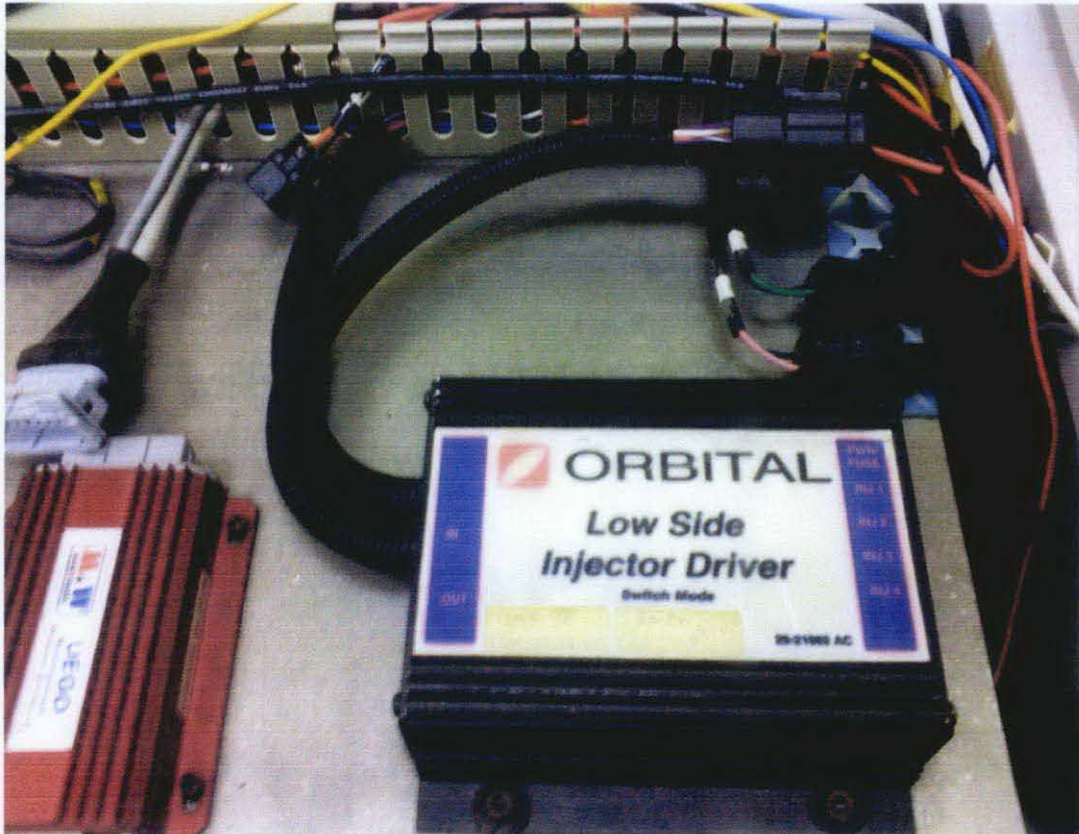

Figure 13: Test using Orbital Injector Driver

Figure 13 shows the “Orbital Low Side Injector Driver” was used to get the benchmark for comparison with the designed injector driver. Both test using same type of fuel injector which is the “Orbital Direct Injector”. The specification for the direct injector is attached in Appendix A.

4.3 Data Analysis

Test was done using Orbital direct injector and low impedance injector driver kit. The result and analysis is shown in following graph.

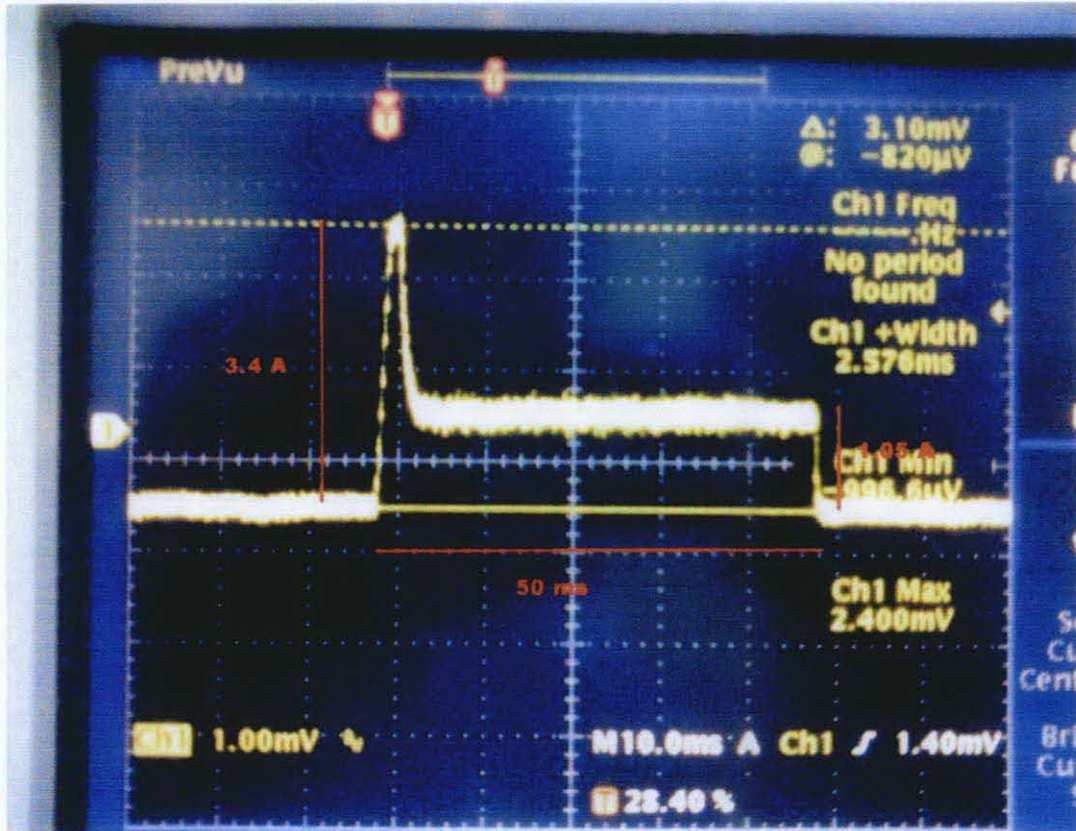

Figure 14: Injector current for 50ms pulse duration

Figure 14 shows the injector peak and hold current for input signal pulse duration is set to 50ms. This value of peak and hold current is fixed for this injector driver. Even if the pulse duration is changed, it will give the same value of 3.4A peak and 1.05A hold current.

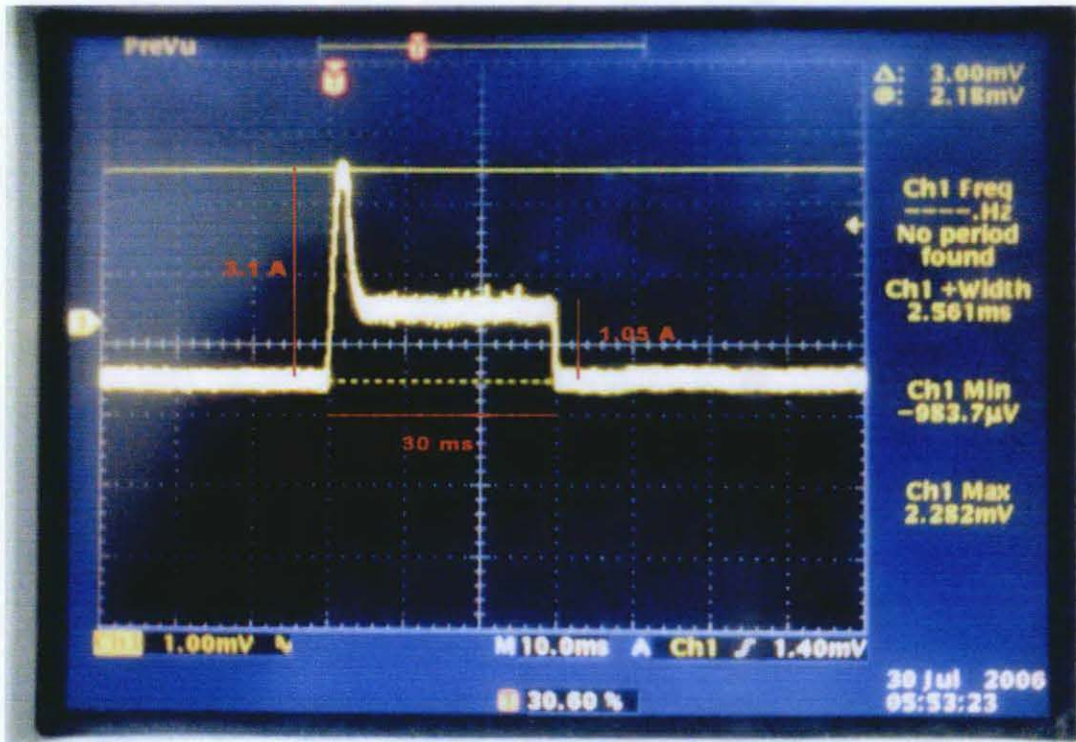

Figure 15: Injector current for 30ms pulse duration

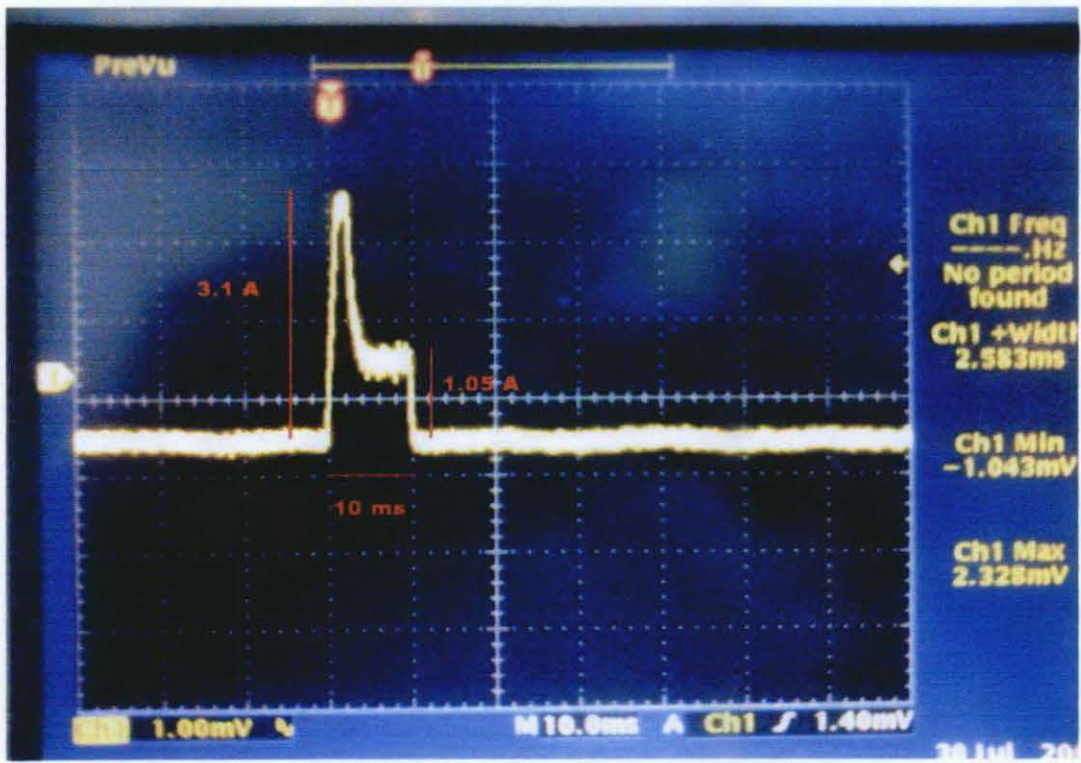

Figure 16: Injector current for 10ms pulse duration

Figure 15 and Figure 16 show the injector current for 30ms and 10ms. It can be seen that the value of peak and hold current not changing for different values of pulse duration. This time cycle can be adjusted depending on the input signal pulses from the PC-based controller.

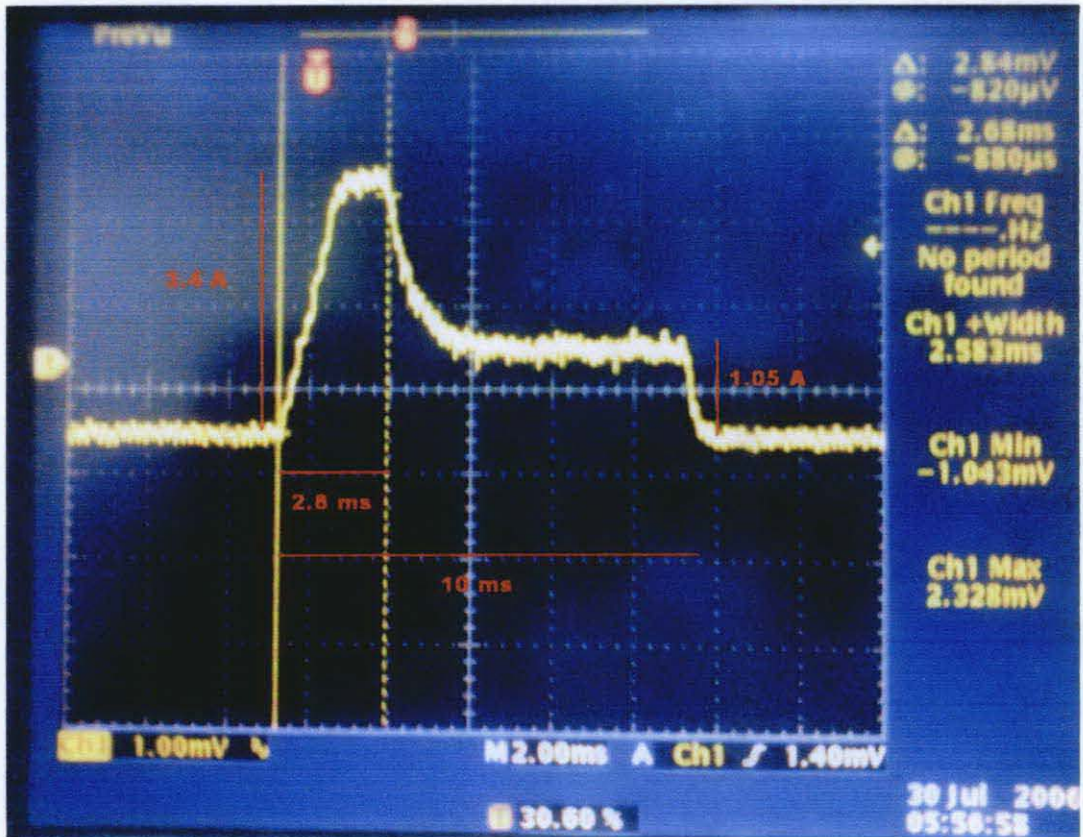

Figure 17: Close up for 10ms pulse duration

Figure 17 shows the close up view for 10ms pulse duration. This is to show that the peak time is fixed at 2.8ms. Although the pulse duration is reduced, the value of peak time is not changing. Thus, although the hold time changes with the pulse duration, the 2.8ms peak time remains the same. Besides, the peak and hold value for current are maintained at 3.4A and 1.05A respectively, regardless of the pulse duration.

CHAPTER 5

CONCLUSIONS AND RECOMMENDATIONS

5.1 Conclusions

At the end of this project, the injector driver circuit has been designed and fabricated on PCB. But the testing on actual automotive direct injector is failed because the circuit did not function properly. The data for Orbital direct injector and low impedance injector driver has been obtained and analyzed. The comparison cannot be done because there are no data on designed injector driver. Thus the project only reaches this stage and no result was obtained for the designed injector driver.

5.2 Recommendations

It is recommended that for future work of the project, some modification will be made to obtain different result. First is to make an adjustable peak and hold current control injector driver. This mean the respective current can be adjust as required by the user. Second recommendation is to modify the parameter value so that the peak time can be changed to give longer hold current state. Another recommendation is to make the circuit also work with high impedance fuel injector.

REFERENCES

- [1] National Semiconductor. (2008). LM1949 Injector Drive Controller. *Datasheet for LM1949 IC*, page 1-12.

- [2] Injectors. (1999). In *Tomco Techtips Issue 38*. Retrieved March 13, 2009, from http://www.tomco-inc.com/Tech_Tips/ttt38.pdf

- [3] Peak and Hold Injector Patterns. (2001). In *Tomco Techtips Issue 40*. Retrieved March 15, 2009, from http://www.tomco-inc.com/Tech_Tips/ttt40.pdf

- [4] Part I: Basics Components of 22R-TE fuel injection system. (2005). In *Electronic Fuel Injection and the 22R-TE engine*. Retrieved April 1, 2009, from <http://www.well.com/user/mosk/EFI1.htm>

- [5] Overview. (2007). In *Peak&Hold Injector Driver Board*. Retrieved February 12, 2009, from http://jbperf.com/p&h_board/index.html

- [6] LabVIEW article. In *Wikipedia*. Retrieved August 19, 2009, from <http://en.wikipedia.org/wiki/LabVIEW>

- [7] Bosch Motorsport Components. (2003). Fuel injectors, page B8.

- [8] Fuel Injector Spotters Guide and Information. (2000). In *RTR performance*. Retrieved August 10, 2009, from <http://www.fuelinjectorguide.htm>

APPENDICES

APPENDIX A

DIRECT INJECTOR SPECIFICATION



Natural Gas Direct Injector



Type	Strata CNG
Nominal pressure	2 MPa
Target Flow	3.0 mg/msec
Nozzle	79 deg exit angle
Actual performance to be confirmed with bench testing	