

**DESIGNING AN ONLINE CONTROLLER FOR  
TEMPERATURE MEASUREMENT**

By

**SYARIFAH AZIZA KAMALIA BINTI SYED FARUK**

**FINAL PROJECT REPORT**

Submitted to the Electrical & Electronics Engineering Programme  
in Partial Fulfillment of the Requirements  
for the Degree  
Bachelor of Engineering (Hons)  
(Electrical & Electronics Engineering)

Universiti Teknologi Petronas  
Bandar Seri Iskandar  
31750 Tronoh  
Perak Darul Ridzuan

© Copyright 2009

by

Syarifah Aziza Kamalia Binti Syed Faruk, 2009

# CERTIFICATION OF APPROVAL

## DESIGNING AN ONLINE CONTROLLER FOR TEMPERATURE MEASUREMENT

by

Syarifah Aziza Kamalia Binti Syed Faruk

A project dissertation submitted to the  
Electrical & Electronics Engineering Programme  
Universiti Teknologi PETRONAS  
in partial fulfilment of the requirement for the  
Bachelor of Engineering (Hons)  
(Electrical & Electronics Engineering)

Approved:

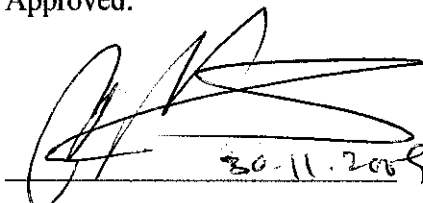
  
20.11.2009  
Dr Taj Mohammad Baloch  
Project Supervisor

Dr Taj Mohammad Baloch  
Senior Lecturer  
Electrical & Electronic Engineering  
Universiti Teknologi PETRONAS  
31750 Tronoh  
Perak Darul Ridzuan, MALAYSIA

UNIVERSITI TEKNOLOGI PETRONAS  
TRONOH, PERAK

December 2009

## **CERTIFICATION OF ORIGINALITY**

This is to certify that I am responsible for the work submitted in this project, that the original work is my own except as specified in the references and acknowledgements, and that the original work contained herein have not been undertaken or done by unspecified sources or persons.



A handwritten signature in black ink, appearing to read 'Syarifah Aziza', is written over a horizontal line.

**Syarifah Aziza Kamalia Binti Syed Faruk**

## **ABSTRACT**

This document reports the progress of the project so far in detail. Here the task done is clearly laid out. Problems encountered were identified and listed. The solutions for each problem were developed as finalizing the design continues. Considering the problems that might arise while completing the project, preventions of such problems are planned. All the future work was scheduled specifically to fabricate the final design chosen. In recent years, the application of controller for measurement based techniques to a wide range of industrial processes has become increasingly common. One reason for this development is the level of development of theory of measurement and its implementation into application tools for feasible use. Controller for measurement is the success of automatic process control, real-monitoring, and a long term performance tracking in improving plant performances depends crucially on measurement. In the oil and gas industry, due to high dissemination levels of many production fields and the complex nature of processes, the need for increased efficiencies and highly effective processing of a large amount of information is particularly evident. Therefore, controller for measurement has been introduced as a plan to contract with indecisive, inexact or qualitative decision making problem. Controllers that unite intelligent and conservative techniques are frequently used in the intelligent control of complex dynamic systems. As a result, the controller can be used to advance on hand conventional control systems in conjunction with an extra level of intelligence to existing control technique to make it more efficient.

## **ACKNOWLEDGEMENTS**

Alhamdulillah, in the name of Allah, Most Gracious and Most Merciful, thank God for His blessings and guidance, at last the author has successfully finished the first part of Final Year Project 1. Above all, we would like to express our gratitude to my supervisor, Dr Taj Mohammad Baloch for the supervision and guidance throughout this project. I appreciate their effort in providing advice, great support and assistance that enable this project to achieve its objectives and be completed successfully within the time frame given.

I would like to acknowledge other Electrical Electronic Engineering lecturers in sharing their expertise in various plant design aspects. With this opportunity, I am able to deepen our knowledge, both in theory and practical in the basic of a design an online controller for temperature measurement.

I would like to my deepest appreciation to my course mates especially Mr Azri Hafiz in exchanging ideas and provide guidance in unfamiliar design characteristics and usage of plant design software.

Lastly but not the least, we would like to show our heartfelt gratitude our family and friends and those who has directly or indirectly involved in this project, for their tremendous support and motivation during undertaking this project.

## TABLE OF CONTENTS

LIST OF TABLES .....	ix
LIST OF FIGURES .....	x
LIST OF ABBREVIATIONS .....	xi
CHAPTER 1 .....	1
1.1 Introduction .....	1
1.2 Problem Statement .....	2
1.3 Process Control Algorithm.....	2
CHAPTER 2 .....	3
2.1 Literature Review .....	3
2.2 The Workhorses .....	5
2.2.1 Thermocouple .....	5
2.2.2 Resistive Temperature Devices .....	7
2.2.3 Thermistors .....	8
2.2.4 Infrared sensors.....	9
CHAPTER 3 .....	11
3.1 Procedure.....	11
3.2 Tool Required.....	12
CHAPTER 4 .....	13
4.1 Circuit Operation.....	13
4.1.1 Transmitter circuit operation .....	14
4.1.2 Receiver circuit operation .....	15
4.2 Modification on Circuit Operation .....	13
4.2.1 Transmitter circuit operation .....	14
4.2.2 Receiver circuit operation .....	14
4.3 Experiment of Accuracy Comparison .....	13
CHAPTER 5 .....	20
5.1 Introduction .....	20
5.2 Recommendation And Future Work Plan .....	20
5.3 Conclusion.....	21
REFERENCES.....	22

APPENDICES .....	23
Appendix A Parts in Circuit.....	24
Appendix B Precision Voltage to Frequency Converters .....	26
Appendix C Precision Centrigade Temperature Sensors .....	33
Appendix D Quad 2 Input Schmitt Nand Gate .....	39

## LIST OF TABLES

Table 1: Medium of measurement is boiled water.....	18
Table 2: Medium of measurement is lukewarm water.....	19
Table 3: Medium of measurement is ice.....	34
Table 4: Ordering Information.....	26
Table 5: Electrical Characteristics for LM331.....	28
Table 6: Electrical Characteristics for LM35.....	34
Table 7: Absolute Maximum Rating for NAND Gate.....	38



## LIST OF FIGURES

Figure 1: Simple Circuit on Temperature Controller .....	3
Figure 2: Thermocouple concept .....	7
Figure 3: Resistance temperature relationship of a thermistor .....	8
Figure 4: Resistance temperature relationship of a thermistor .....	8
Figure 5: Thermistor Sensor .....	9
Figure 6: Methodology Flowchart .....	12
Figure 7: Transmitter Circuit .....	13
Figure 8: Receiver Circuit.....	14
Figure 9: Circuit Operation when LM35 touched ice and hot water .....	15
Figure 10: Transmitter (433MHz).....	16
Figure 11: RF transmitter module CS901.....	16
Figure 12: RF receiver module CS902.....	17
Figure 13: Transmitter and Receiver Circuit.....	17
Figure 14: Comparison between the prototype and alcohol thermometer as reference temperature.....	19

## **LIST OF ABBREVIATIONS**

**RTD**      **Resistive Temperature Device**

**T**          **Temperature**

**IC**        **Integrated Circuit**

**Q**         **Transistor**

# CHAPTER 1

## INTRODUCTION

### 1.1 Introduction

Human progress from a primitive state to our present complex, technological world has been marked by learning new and improved methods to control the environment. The term control means methods to force parameters in the environment to have specific values. This can be as simple as making the temperature in a room stay some certain value or as complex as manufacturing an integrated circuit or guiding a spacecraft to other planets in the galaxy.

When the value of a variable is needed, it can be obtained from at least two real-time methods. First, it can be measured “directly” by a sensor; as an example, a temperature can be measured by a thermocouple, although the actual value sensed is the voltage generated for a bimetallic connection with nodes at two temperature; the references and process temperatures.

This sensor is called direct sensor because the physical principle underlying the measurement is independent of the process application and the relationship between the sensor signal and process variable is level, pressure, temperature, and flows of many fluids. Also, the compositions and physical properties of some process streams can be determined in real-time with on-stream analyzers.

In the second method, the variable cannot be measured, at least at reasonable cost, in real-time, but it can be inferred using other measurement and a process-specific correlation.

Not all variables can be measured in real time. These variables have to be determined through analysis of sample material. When the sample and analysis can be performed quickly the value can be used in feedback control. These are many industrial examples of controllers that use results and are executed every few hours.

While not providing control performances as good as would be possible with on-stream analysis, this approach usually gives much better performances than not using lab value.

## **1.2 Problem Statement**

Many problems encountered in designing the controller which include this process:

- To develop the actual circuit both for transmitter and receiver.
- To encounter with the complexity of receiver circuit.
- To design circuit for the mathematical model and simulation model.

## **1.3 Process Control Algorithm**

The process control algorithm undertakes the following procedure:

1. Measurement of a certain output based on the sensors input to the controller
2. Controller decision on the required state.
3. Output signal to the plant from the controller, manipulating the process.
4. Plant process operation based on the controller's decision.

## CHAPTER 2

### LITERATURE REVIEW

#### 2.1 Literature Review

The control system for modern industrial plants typically includes thousands of individual control loops. During control system design, preliminary controller settings are specified based on process knowledge, control objectives and prior experience. After a controller is installed, the preliminary setting often to be satisfactory but for critical control loops, the preliminary settings may have to be adjusted in order to achieve satisfactory control. This is called online controller.

Online controller tuning involves plant testing, often on a trial and error basis, the tuning can be quite tedious and time consuming. Consequently, good initial controller settings are very desirable to reduce the required time and effort. Ideally, the preliminary settings from the control system design can be used as the initial field settings. If the preliminary settings are not satisfactory, alternative settings can be obtained from simple experiment tests. If necessary, the settings can be fine tuned by a modest amount of trial and error.

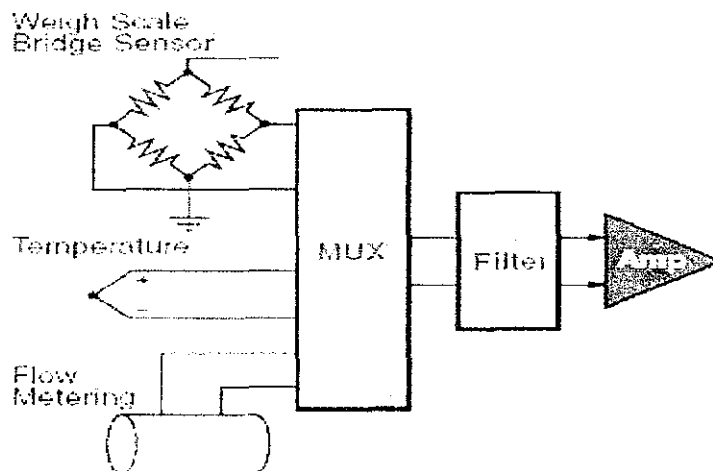

Figure 1: Simple Circuit on Temperature Controller

Temperature can be measured via a diverse array of sensors. All of them infer temperature by sensing some change in a physical characteristic. Six types with which the engineer is likely to come into contact are: *thermocouples, resistive temperature devices (RTDs and thermistors), infrared radiators, bimetallic devices, liquid expansion devices, and change-of-state devices.*

Thermocouples consist essentially of two strips or wires made of different metals and joined at one end. As discussed later, changes in the temperature at that juncture induce a change in electromotive force (emf) between the other ends. As temperature goes up, this output (emf) of the thermocouple rises, though not necessarily linearly.

Resistive temperature devices capitalize on the fact that the electrical resistance of a material changes as its temperature changes. Two key types are the metallic devices (commonly referred to as RTDs), and thermistors. As their name indicates, RTDs rely on resistance change in a metal, with the resistance rising more or less linearly with temperature. Thermistors are based on resistance change in a ceramic semiconductor; the resistance drops nonlinearly with temperature rise.

Infrared sensors are non-contacting devices. They infer temperature by measuring the thermal radiation emitted by a material.

Bimetallic devices take advantage of the difference in rate of thermal expansion between different metals. Strips of two metals are bonded together. When heated, one side will expand more than the other, and the resulting bending is translated into a temperature reading by mechanical linkage to a pointer. These devices are portable and they do not require a power supply, but they are usually not as accurate as thermocouples or RTDs and they do not readily lend themselves to temperature recording.

Fluid-expansion devices, typified by the household thermometer, generally come in two main classifications: the mercury type and the organic-liquid type. Versions employing gas instead of liquid are also available. Mercury is considered an environmental hazard, so there are regulations governing the shipment of devices that contain it. Fluid-expansion sensors do not require electric power, do not pose explosion hazards, and are stable even after repeated cycling. On the other hand, they

do not generate data that are easily recorded or transmitted, and they cannot make spot or point measurements.

Change-of-state temperature sensors consist of labels, pellets, crayons, lacquers or liquid crystals whose appearance changes once a certain temperature is reached. They are used, for instance, with steam traps - when a trap exceeds a certain temperature, a white dot on a sensor label attached to the trap will turn black. Response time typically takes minutes, so these devices often do not respond to transient temperature changes. And accuracy is lower than with other types of sensors. Furthermore, the change in state is irreversible, except in the case of liquid-crystal displays. Even so, change-of-state sensors can be handy when one needs confirmation that the temperature of a piece of equipment or a material has not exceeded a certain level, for instance for technical or legal reasons during product shipment.

## **2.2 The Workhorses**

In the chemical process industries, the most commonly used temperature sensors are thermocouples, resistive devices and infrared devices. There is widespread misunderstanding as to how these devices work and how they should be used.

### **2.2.1 Thermocouple**

Consider first the thermocouple, probably the most-often-used and least-understood of the three. Essentially, a thermocouple consists of two alloys joined together at one end and open at the other. The (emf) at the output end (the open end; V1 in Figure 2a) is a function of the temperature T1 at the closed end. As the temperature rises, the emf goes up.

Often the thermocouple is located inside a metal or ceramic shield that protects it from a variety of environments. Metal-sheathed thermocouples are also available with many types of outer coatings, such as polytetrafluoroethylene, for trouble-free use in corrosive solutions.

The open-end emf is a function of not only the closed-end temperature (i.e., the temperature at the point of measurement) but also the temperature at the open end (T2 in Figure 2a). Only by holding T2 at a standard temperature can the measured emf be considered a direct function of the change in T1. The industrially accepted standard for T2 is 0°C; therefore, most tables and charts make the assumption that T2 is at that level. In industrial instrumentation, the difference between the actual temperature at T2 and 0°C is usually corrected for electronically, within the instrumentation. This emf adjustment is referred to as the cold-junction, or CJ, correction.

The composition of the junction itself does not affect the thermocouple action in any way, so long as the temperature, T1, is kept constant throughout the junction and the junction material is electrically conductive (Figure 2b). Similarly, the reading is not affected by insertion of non-thermocouple alloys in either or both leads, provided that the temperature at the ends of the "spurious" material is the same (Figure 2c).

It is important to be aware of what might be called the Law of Successive Thermocouples. Of the two elements that are shown in the upper portion of Figure 2d, one thermocouple has T1 at the hot end and T2 at the open end. The second thermocouple has its hot end at T2 and its open end at T3. The emf level for the thermocouple that is measuring T1 is V1; that for the other thermocouple is V2. The sum of the two emfs, V1 plus V2, equals the emf V3 that would be generated by the combined thermocouple operating between T1 and T3. By virtue of this law, a thermocouple designated for one open-end reference temperature can be used with a different open-end temperature.



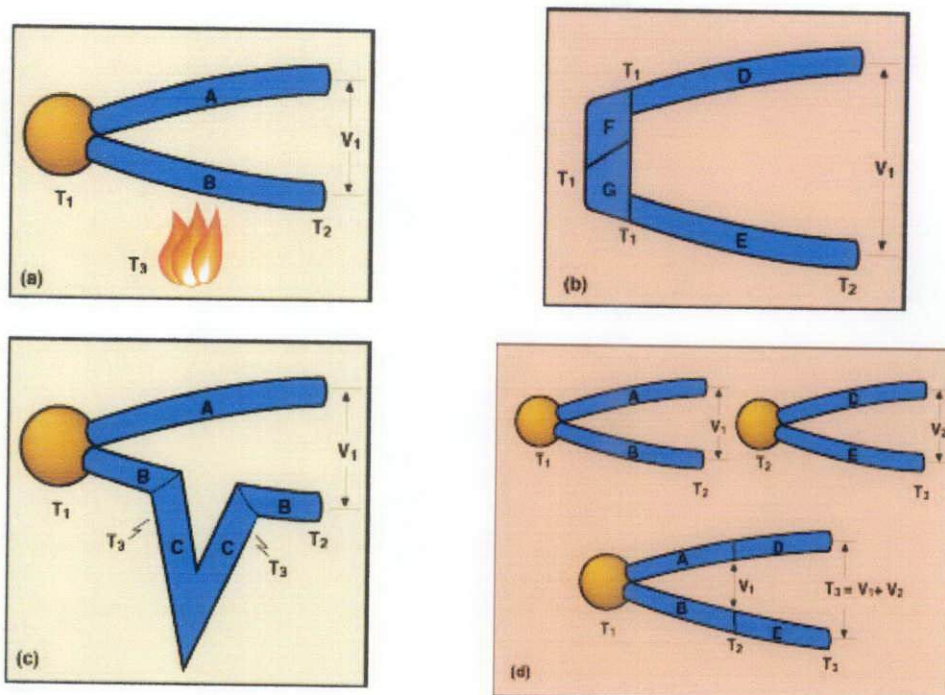

Figure 2: Thermocouple concept

### 2.2.2 Resistive Temperature Devices

A typical RTD consists of a fine platinum wire wrapped around a mandrel and covered with a protective coating. Usually, the mandrel and coating are glass or ceramic.

The mean slope of the resistance vs temperature plot for the RTD is often referred to as the alpha value (Figure 2), alpha standing for the temperature coefficient. The slope of the curve for a given sensor depends somewhat on purity of the platinum in it.

The most commonly used standard slope, pertaining to platinum of a particular purity and composition, has a value of 0.00385 (assuming that the resistance is measured in ohms and the temperature in degrees Celsius). A resistance vs temperature curve drawn with this slope is a so-called European curve, because RTDs of this composition were first used extensively on that continent. Complicating the picture, there is also another standard slope, pertaining to a slightly different platinum composition. Having a slightly higher alpha value of 0.00392, it follows what is known as the American curve.

If the alpha value for a given RTD is not specified, it is usually 0.00385. However, it is prudent to make sure of this, especially if the temperatures to be measured are high. This point is brought out in Figure 2, which shows both the European and American curves for the most widely used RTD, namely one that exhibits 100 ohms resistance at 0°C.



Figure 3: Resistive Temperature Device

### 2.2.3 Thermistors

The resistance-temperature relationship of a thermistor is negative and highly nonlinear. This poses a serious problem for engineers who must design their own circuitry. However, the difficulty can be eased by using thermistors in matched pairs, in such a way that the nonlinearities offset each other. Furthermore, vendors offer panel meters and controllers that compensate internally for thermistors' lack of linearity.

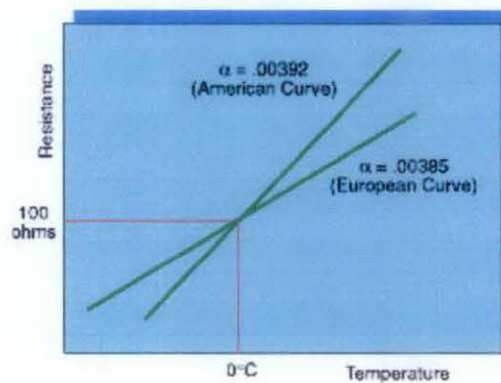

Figure 4: Resistance temperature relationship of a thermistor

Thermistors are usually designated in accordance with their resistance at 25°C. The most common of these ratings is 2252 ohms; among the others are 5,000 and 10,000 ohms. If not specified to the contrary, most instruments will accept the 2252 type of thermistor.

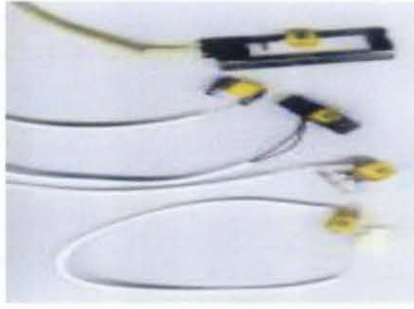

Figure 5: Thermistor Sensor

#### 2.2.4 *Infrared sensors*

These measure the amount of radiation emitted by a surface. Electromagnetic energy radiates from all matter regardless of its temperature. In many process situations, the energy is in the infrared region. As the temperature goes up, the amount of infrared radiation and its average frequency go up.

Different materials radiate at different levels of efficiency. This efficiency is quantified as emissivity, a decimal number or percentage ranging between 0 and 1 or 0% and 100%. Most organic materials, including skin, are very efficient, frequently exhibiting emissivities of 0.95. Most polished metals, on the other hand, tend to be inefficient radiators at room temperature, with emissivity or efficiency often 20% or less.

To function properly, an infrared measurement device must take into account the emissivity of the surface being measured. This can often be looked up in a reference table. However, bear in mind that tables cannot account for localized conditions such as oxidation and surface roughness. A sometimes practical way to measure temperature with infrared when the emissivity level is not known is to "force" the emissivity to a known level, by covering the surface with masking tape (emissivity of 95%) or a highly emissive paint.

Some of the sensor input may well consist of energy that is not emitted by the equipment or material whose surface is being targeted, but instead is being reflected by that surface from other equipment or material. Emissivity pertains to energy radiating from a surface whereas reflection pertains to energy reflected from another source. Emissivity of an opaque material is an inverse indicator of its reflectivity. Substances that are good emitters do not reflect much incident energy, and thus do not

pose much of a problem to the sensor in determining surface temperatures. Conversely, when one measures a target surface with only, say, 20% emissivity, much of the energy reaching the sensor might be due to reflection from, e.g., a nearby furnace at some other temperature. In short, be wary of hot, spurious reflected targets.

An infrared device is like a camera, and thus covers a certain field of view. It might, for instance, be able to “see” a 1-deg visual cone or a 100-deg cone. When measuring a surface, be sure that the surface completely fills the field of view. If the target surface does not at first fill the field of view, move closer, or use an instrument with a narrower field of view. Or, simply take the background temperature into account (i.e., to adjust for it) when reading the instrument.

## **CHAPTER 3**

### **METHODOLOGY AND PROJECT WORK**

#### **3.1 Procedure Identification**

This project is a two semester project. The first half of the project is to understand the controller and the second half is to design circuit. The complete project planning is as figure below. The first thing to do is to find the specification of the controller. This required student to study from many source to find the correct specification. Next is to design the circuit and capture the schematic. Lastly is circuit validation before proceed to layout design.

Second half of the project starts with design of actual circuit and also the simulation in the Pspice.

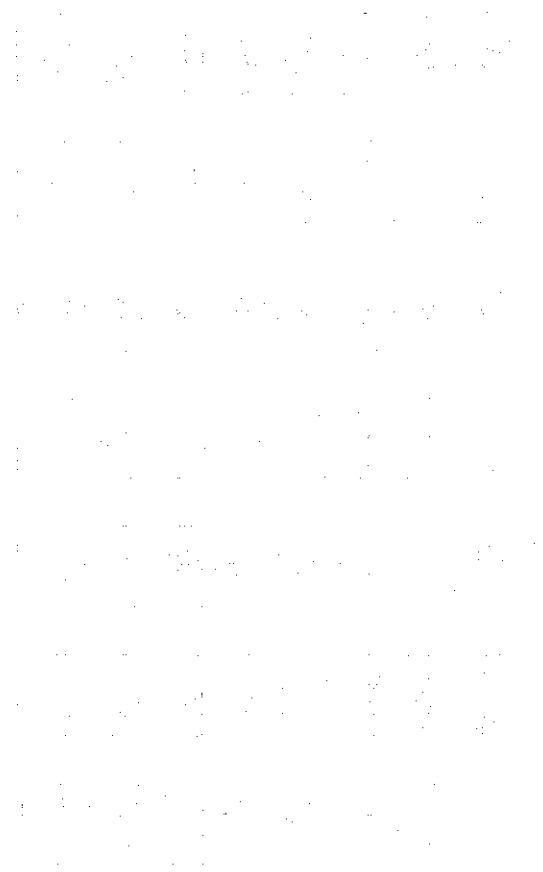

**Figure 6: Methodology Flowchart**

### **3.2 Tool Required**

This project is simulation based only. The software that will be used for design circuit and layout is Pspice design software and MultiSim Software..

## CHAPTER 4

### RESULTS AND DISCUSSION

#### 4.1 Circuit Operation

This circuit is intended for precision centigrade temperature measurement, with a transmitter section converting to frequency the sensor's output voltage, which is proportional to the measured temperature. The output frequency bursts are conveyed into the mains supply cables.

The receiver section counts the signal coming from mains supply and shows the counting on three 7-segment LED displays. The least significant digit displays tenths of degree and then a 00.0 to 99.9 °C range is obtained. Transmitter-receiver distance can reach hundred meters, provided both units are connected to the mains supply within the control of the same light-meter.

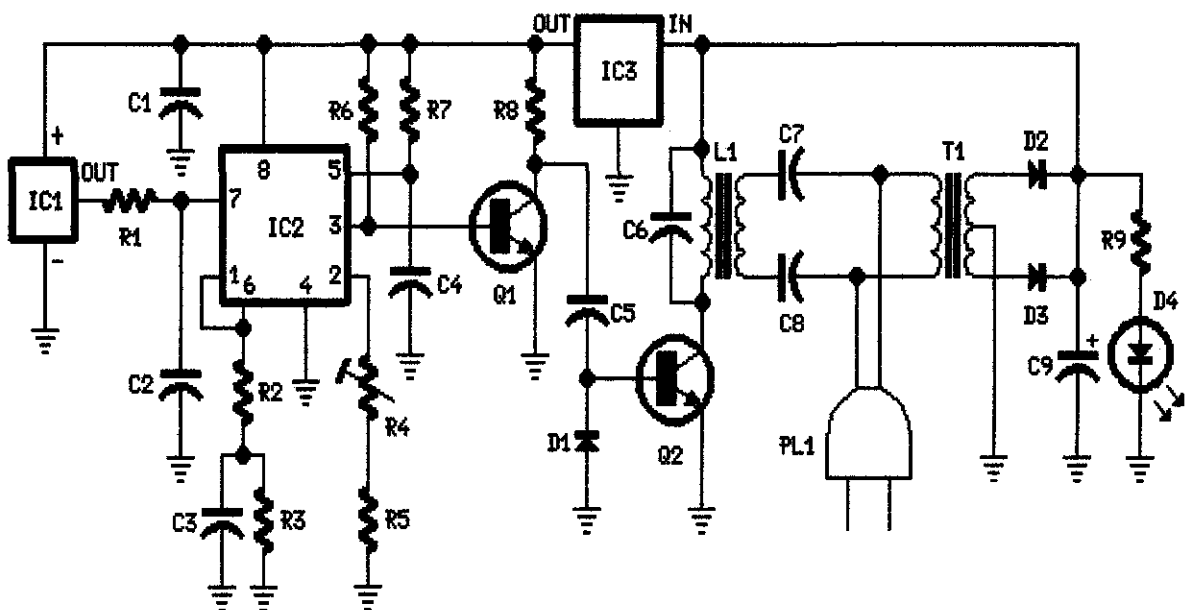

Figure 7: Transmitter Circuit

### 4.1.2 Transmitter circuit operation

IC1 is a precision centigrade temperature sensor with a linear output of 10mV/°C driving IC2, a voltage-frequency converter. At its output pin (3), an input of 10mV is converted to 100Hz frequency pulses. Thus, for example, a temperature of 20°C is converted by IC1 to 200mV and then by IC2 to 2KHz. Q1 is the driver of the power output transistor Q2, coupled to the mains supply by L1 and C7, C8.

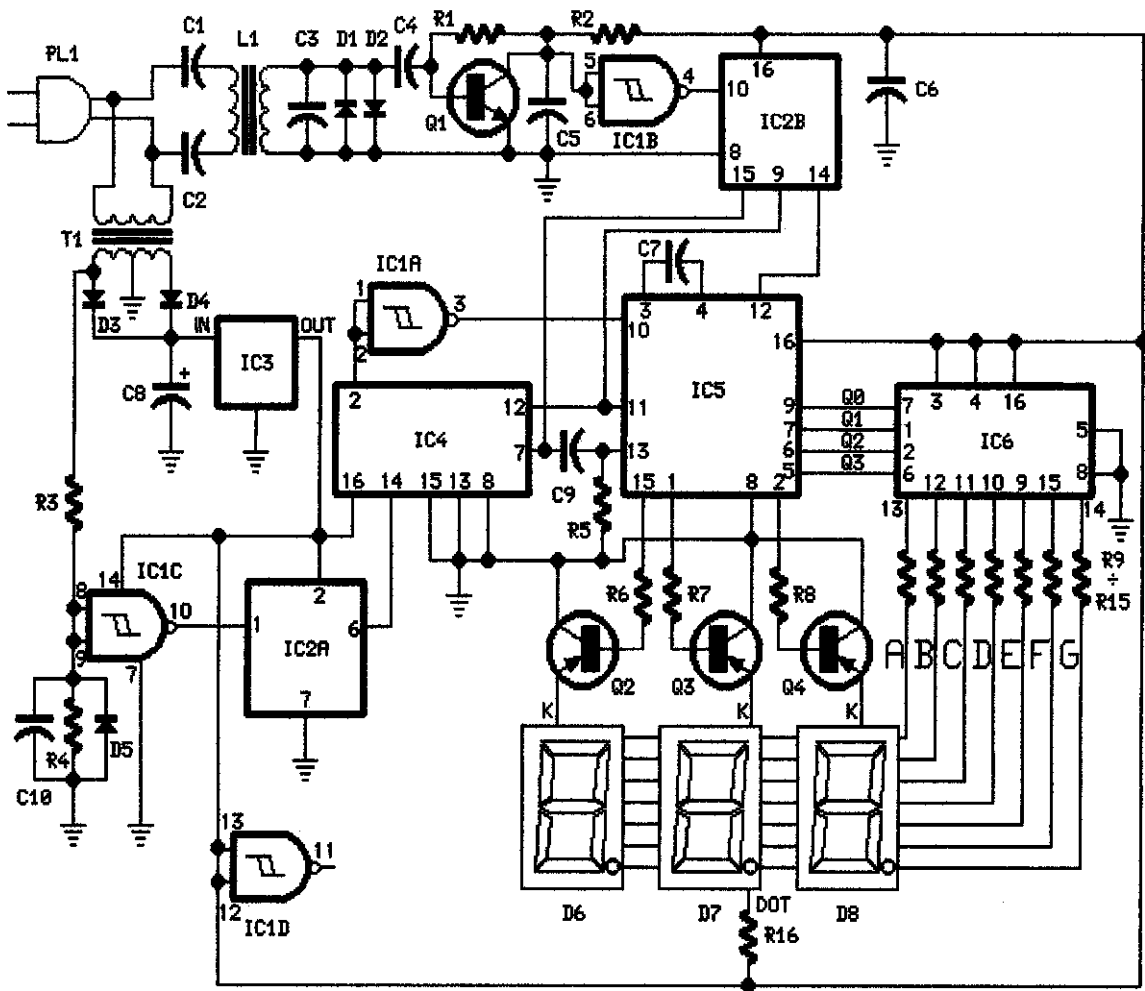

Figure 8: Receiver Circuit



#### 4.1.2 Receiver circuit operation

The frequency pulses coming from mains supply and safely insulated by C1, C2 & L1 are amplified by Q1; diodes D1 and D2 limiting peaks at its input. Pulses are filtered by C5, squared by IC1B, divided by 10 in IC2B and sent for the final count to the clock input of IC5. IC4 is the time-base generator: it provides reset pulses for IC1B and IC5 and enables latches and gate-time of IC5 at 1Hz frequency. It is driven by a 5Hz square wave obtained from 50Hz mains frequency picked-up from T1 secondary, squared by IC1C and divided by 10 in IC2A. IC5 drives the displays' cathodes via Q2, Q3 & Q4 at a multiplexing rate frequency fixed by C7. It drives also the 3 displays' paralleled anodes via the BCD-to-7 segment decoder IC6. Summing up, input pulses from mains supply at, say, 2KHz frequency, are divided by 10 and displayed as 20.0°C.

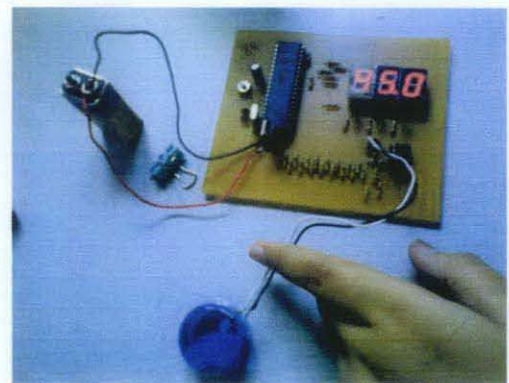
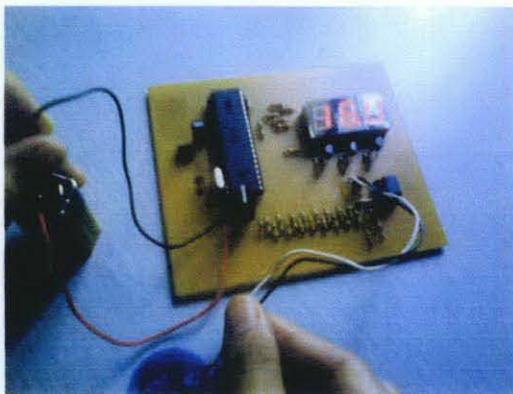
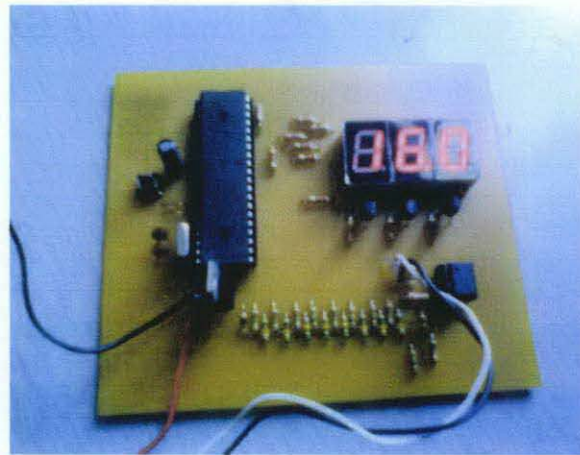

Figure 9: Circuit Operation when LM35 touched ice and hot water

## 4.2 Modification on the Circuit

Due to some component not available in store, some modifications have been made to the circuit. The transmitter circuit has been simplified like below:

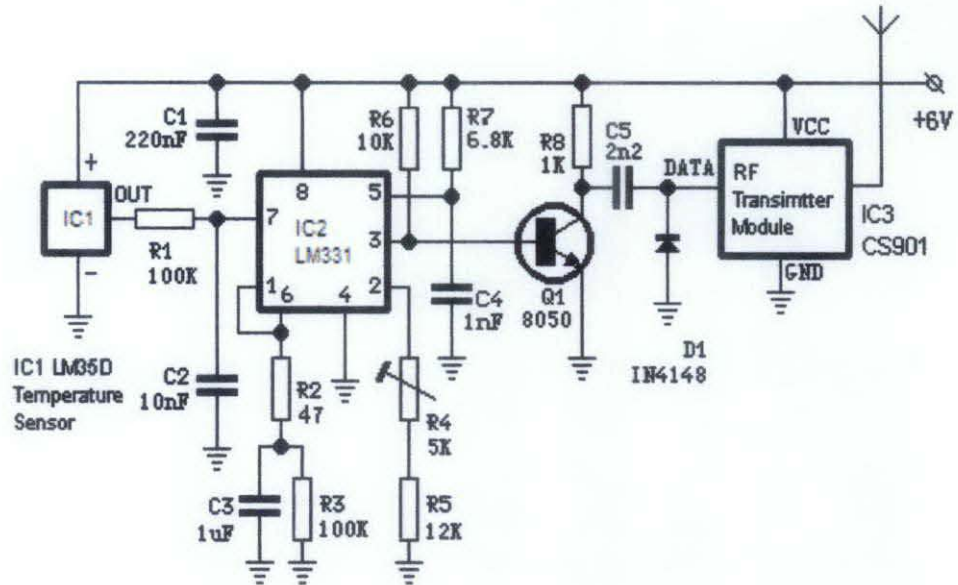

Figure 10: Transmitter (433MHz)

### 4.2.2 Modified Transmitter circuit operation

IC1 is a precision centigrade temperature sensor with a linear output of  $10\text{mV}/^\circ\text{C}$  driving IC2, a voltage-frequency converter. At its output pin (3), an input of  $10\text{mV}$  is converted to  $100\text{Hz}$  frequency pulses. Thus, for example, a temperature of  $20^\circ\text{C}$  is converted by IC1 to  $200\text{mV}$  and then by IC2 to  $2\text{KHz}$ . Q1 is the driver of the power output transmitter module CS901(**figure 11**).

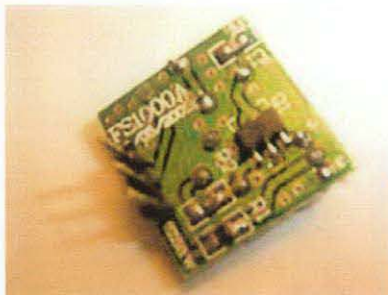

Figure 11: RF transmitter module CS901

#### ***4.2.2 Modified Receiver circuit operation***

Instead of putting the main supply to produce the frequency, we had the frequency pulses coming out from RF receiver module CS902 (**figure 12**)

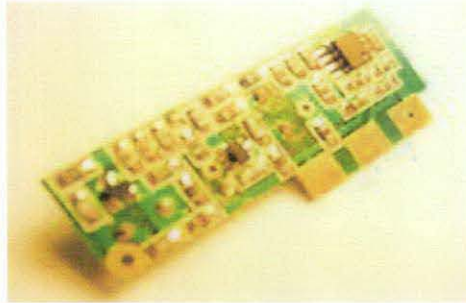

Figure 12: RF receiver module CS902

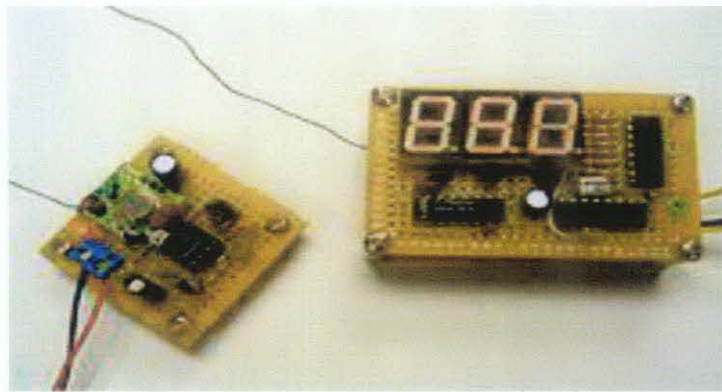

Figure 13: Transmitter and Receiver Circuit

### 4.3 Experiment of Accuracy Comparison

This experiment is created to compare the accuracy of the prototype with the reference temperature measured by an alcohol temperature. This experiment will prove that the prototype is working as accurate as the alcohol thermometer.

There are three medium used in the experiment which includes, boiled water, lukewarm water and ice. Several measurements were taken in this experiment and the value of the average is calculated. The result is as shown in tables below:

Number of Experiment	Measurement Medium	Time Taken,s	Temperature Reference using thermometer, °C	Temperature taken, °C
1	Boiled Water	10	100	98
2	Boiled Water	12	100	98
3	Boiled Water	12	100	99
Average		11	100	98.5

Table 1: Medium of measurement is boiled water

Number of Experiment	Measurement Medium	Time Taken,s	Temperature Reference using Thermometer, °C	Temperature taken, °C
1	Lukewarm Water	8	55	50
2	Lukewarm Water	9	60	48
3	Lukewarm Water	6	62	40
Average		7.6	59	46

Table 2: Medium of measurement is Lukewarm water

Number of Experiment	Measurement Medium	Time Taken,s	Temperature Reference using thermometer, °C	Temperature taken, °C
1	Ice	11	8.4	11.4
2	Ice	12	11.8	11.3
3	Ice	12	9.8	11.3
Average		11.7	10.0	11.35

Table 3: Medium of measurement is ice

After all data is collected, the author plotted the value on excel and get the graph as shown below:

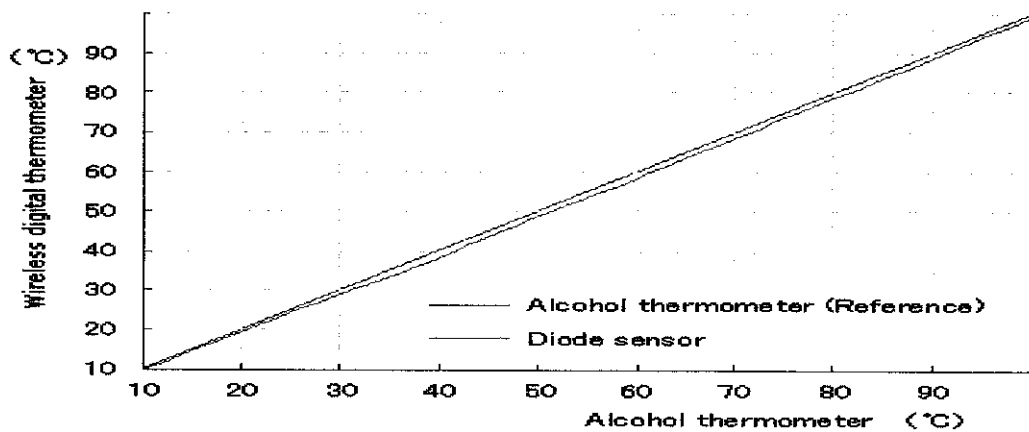

Figure 14: Comparison between the prototype and alcohol thermometer as reference temperature

As we can see from the graph, the author can conclude that the prototype is accurate compared to a reference temperature even though there are a slight difference between the two line.

## **CHAPTER 5**

### **RECOMMENDATION AND CONCLUSION**

#### **5.1 Introduction**

For this final part of the report, the author had included the suggested recommendation and future work plan with respect to the project and also necessary expansion and continuation for the upcoming work. Lastly the report will finished off with the conclusion, summarizing all relevance information within this project.

#### **5.2 Recommendation and Future Work Plan**

So far to the author's observation, there are few recommendation can be made to ensure a better outcome towards this project. So far it was a great success to finally do the actual circuit even though both circuits is complex and while there will definitely be future plan to finish this projects, below are some recommendation(s) that can be made:

- To replace the bread board with permanent board.
- To create a workpiece box to put the circuit inside so that it will appear presentable for the exhibition.

As for the future work plan, the author will be looking to continue the progress which will commence within the next left months. Future work plans for this project includes:

1. To experiment the circuit by using a set of a parameters with temperature variable.
2. To collect the data in the experiment.

### **5.3 Conclusion**

These days, many accidents happened in the plant and in high risk area on platform, factory and etc. Online controller help persona for example engineers and technicians to record the measurement without having to go to the high risk and dangerous places. This project have two part to accomplish which is part 1 is the simulation of the Temperature Measurement controller circuit. Meanwhile, part 2 is the development of the circuit of both Transmitter and Receiver circuit. By referring to project flow, this project progress is smooth as plan. Out of that, other task that can be done is to improve understanding on design knowledge and other technique of design.

## **APPENDICES**



## APPENDIX A

### PARTS IN CIRCUIT

#### Transmitter:

R1,R3	100K	1/4W Resistors
R2	47R	1/4W Resistor
R4	5K	1/2W Trimmer Cermet
R5	12K	1/4W Resistor
R6	10K	1/4W Resistor
R7	6K8	1/4W Resistor
R8,R9	1K	1/4W Resistors
C1	220nF	63V Polyester Capacitor
C2	10nF	63V Polyester Capacitor
C3	1 $\mu$ F	63V Polyester Capacitor
C4,C6	1nF	63V Polyester Capacitors
C5	2n2	63V Polyester Capacitor
C7,C8	47nF	400V Polyester Capacitors
C9	1000 $\mu$ F	25V Electrolytic Capacitor
D1	1N4148	75V 150mA Diode
IC1	LM35	Linear temperature sensor IC
IC2	LM331	Voltage-frequency converter IC
IC3	78L06	6V 100mA Voltage regulator IC
Q1	9014/8050(BC238)	25V 100mA NPN Transistor
IC3	CS901	RF Transmitter Module (433MHz) [Parts Available]

## Receiver:

R1,R2,R4,R5,R6	12K	1/4W Resistor
R3	47K	1/4W Resistor
R7-R13,R14	220R	1/4W Resistors
C1,C2,C6,	220nF	63V Polyester Capacitors
C3	1nF	63V Polyester Capacitors
C4	100pF	63V Polyester Capacitor
C5	100µF	63V Polyester Capacitors
D1,D2,	1N4002	100V 1A Diodes
D3	1N4148	75V 150mA Diodes
D6-D8		Common-cathode 7-segment LED mini-displays
IC0	CS902	RF receiver Module [Parts Available]
IC1	CD4093	Quad 2 input Schmitt NAND Gate IC
IC2	CD4518	Dual BCD Up-Counter IC
IC3	78L12	12V 100mA Voltage regulator IC
IC4	CD4017	Decade Counter with 10 decoded outputs IC
IC5	CD4553	Three-digit BCD Counter IC
IC6	CD4511	BCD-to-7-Segment Latch/Decoder/Driver IC
Q2-Q4	8550(BC327)	45V 800mA PNP Transistors
T1	Power transformer	2200V Primary,12+12V Secondary 3VA Mains transformer

## APPENDIX B

# PRECISION VOLTAGE-TO-FREQUENCY CONVERTERS

### General Description

The LM231/LM331 family of voltage-to-frequency converters is ideally suited for use in simple low-cost circuits for analog-to-digital conversion, precision frequency-to-voltage conversion, long-term integration, linear frequency modulation or demodulation, and many other functions. The output when used as a voltage-to-frequency converter is a pulse train at a frequency precisely proportional to the applied input voltage. Thus, it provides all the inherent advantages of the voltage-to-frequency conversion techniques, and is easy to apply in all standard voltage-to-frequency converter applications.

Further, the LM231A/LM331A attain a new high level of accuracy versus temperature which could only be attained with expensive voltage-to-frequency modules. Additionally the LM231/331 are ideally suited for use in digital systems at low power supply voltages and can provide low-cost analog-to-digital conversion in microprocessor controlled systems. And, the frequency from a battery powered voltage-to-frequency converter can be easily channeled through a simple photo isolator to provide isolation against high common mode levels.

The LM231/LM331 utilize a new temperature-compensated band-gap reference circuit, to provide excellent accuracy over the full operating temperature range, at power supplies as low as 4.0V. The precision timer circuit has low bias currents without degrading the quick response necessary for 100 kHz voltage-to-frequency conversion. And the output are capable of driving 3 TTL loads, or a high voltage output up to 40V, yet is short-circuit-proof against VCC.

## Features

- Guaranteed linearity 0.01% max
- Improved performance in existing voltage-to-frequency conversion applications
- Split or single supply operation
- Operates on single 5V supply
- Pulse output compatible with all logic forms
- Excellent temperature stability:  $\pm 50$  ppm/ $^{\circ}\text{C}$  max
- Low power consumption: 15 mW typical at 5V
- Wide dynamic range, 100 dB min at 10 kHz full scale frequency
- Wide range of full scale frequency: 1 Hz to 100 kHz
- Low cost

## Connection Diagram

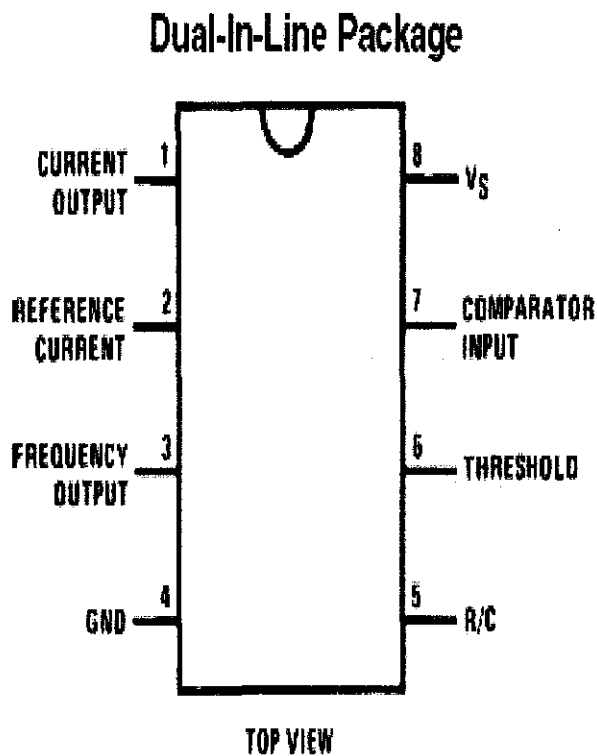

## Ordering Information

Device	Temperature Range	Package
LM231N	$-25^{\circ}\text{C} \leq T_A \leq +85^{\circ}\text{C}$	N08E (DIP)
LM231AN	$-25^{\circ}\text{C} \leq T_A \leq +85^{\circ}\text{C}$	N08E (DIP)
LM331N	$0^{\circ}\text{C} \leq T_A \leq +70^{\circ}\text{C}$	N08E (DIP)
LM331AN	$0^{\circ}\text{C} \leq T_A \leq +70^{\circ}\text{C}$	N08E (DIP)

Table 1: Ordering Information

## Operation Rating

### Operating Ambient Temperature

LM231, LM231A                       $-25^{\circ}\text{C}$  to  $+85^{\circ}\text{C}$

LM331, LM331A                       $0^{\circ}\text{C}$  to  $+70^{\circ}\text{C}$

Supply Voltage,  $V_S$                        $+4\text{V}$  to  $+40\text{V}$

## Electrical Characteristics

All specifications apply in the circuit of Figure 4, with  $4.0V \leq V_S \leq 40V$ ,  $T_A=25^\circ C$ , unless otherwise specified.

Parameter	Conditions	Min	Typ	Max	Units
VFC Non-Linearity (Note 4)	$4.5V \leq V_S \leq 20V$		$\pm 0.003$	$\pm 0.01$	% Full-Scale
	$T_{MIN} \leq T_A \leq T_{MAX}$		$\pm 0.006$	$\pm 0.02$	% Full-Scale
VFC Non-Linearity in Circuit of Figure 3	$V_S = 15V$ , $f = 10 \text{ Hz to } 11 \text{ kHz}$		$\pm 0.024$	$\pm 0.14$	% Full-Scale
Conversion Accuracy Scale Factor (Gain)					
LM231, LM231A	$V_{IN} = -10V$ , $R_S = 14 \text{ k}\Omega$	0.95	1.00	1.05	kHz/V
LM331, LM331A		0.90	1.00	1.10	kHz/V
Temperature Stability of Gain					
LM231/LM331	$T_{MIN} \leq T_A \leq T_{MAX}$ , $4.5V \leq V_S \leq 20V$		$\pm 30$	$\pm 150$	ppm/ $^\circ C$
LM231A/LM331A			$\pm 20$	$\pm 50$	ppm/ $^\circ C$
Change of Gain with $V_S$	$4.5V \leq V_S \leq 10V$		0.01	0.1	%/V
	$10V \leq V_S \leq 40V$		0.006	0.06	%/V
Rated Full-Scale Frequency	$V_{IN} = -10V$	10.0			kHz
Gain Stability vs. Time (1000 Hours)	$T_{MIN} \leq T_A \leq T_{MAX}$		$\pm 0.02$		% Full-Scale
Over Range (Beyond Full-Scale) Frequency	$V_{IN} = -11V$	10			%
<b>INPUT COMPARATOR</b>					
Offset Voltage			$\pm 3$	$\pm 10$	mV
LM231/LM331	$T_{MIN} \leq T_A \leq T_{MAX}$		$\pm 4$	$\pm 14$	mV
LM231A/LM331A	$T_{MIN} \leq T_A \leq T_{MAX}$		$\pm 3$	$\pm 10$	mV
Bias Current			-80	-300	nA
Offset Current			$\pm 8$	$\pm 100$	nA
Common-Mode Range	$T_{MIN} \leq T_A \leq T_{MAX}$	-0.2		$V_{CC}-2.0$	V
<b>TIMER</b>					
Timer Threshold Voltage, Pin 5		0.63	0.667	0.70	$\times V_S$
Input Bias Current, Pin 5	$V_S = 15V$				
All Devices	$0V \leq V_{PIN 5} \leq 9.9V$		$\pm 10$	$\pm 100$	nA
LM231/LM331	$V_{PIN 5} = 10V$		200	1000	nA
LM231A/LM331A	$V_{PIN 5} = 10V$		200	500	nA
$V_{SAT \text{ PIN } 5}$ (Reset)	$I = 5 \text{ mA}$		0.22	0.5	V
<b>CURRENT SOURCE (Pin 1)</b>					
Output Current					
LM231, LM231A	$R_S = 14 \text{ k}\Omega$ , $V_{PIN 1} = 0$	126	135	144	$\mu A$
LM331, LM331A		116	136	156	$\mu A$
Change with Voltage	$0V \leq V_{PIN 1} \leq 10V$		0.2	1.0	$\mu A$
Current Source OFF Leakage					

<b>Electrical Characteristics</b> (Continued)					
All specifications apply in the circuit of <i>Figure 4</i> , with $4.0V \leq V_S \leq 40V$ , $T_A=25^\circ C$ , unless otherwise specified.					
Parameter	Conditions	Min	Typ	Max	Units
<b>CURRENT SOURCE (Pin 1)</b>					
LM231, LM231A, LM331, LM331A			0.02	10.0	nA
All Devices	$T_A = T_{MAX}$		2.0	50.0	nA
Operating Range of Current (Typical)			(10 to 500)		$\mu A$
<b>REFERENCE VOLTAGE (Pin 2)</b>					
LM231, LM231A		1.76	1.89	2.02	$V_{DC}$
LM331, LM331A		1.70	1.89	2.08	$V_{DC}$
Stability vs. Temperature			$\pm 60$		ppm/ $^\circ C$
Stability vs. Time, 1000 Hours			$\pm 0.1$		%
<b>LOGIC OUTPUT (Pin 3)</b>					
$V_{SAT}$	$I = 5 \text{ mA}$		0.15	0.50	V
	$I = 3.2 \text{ mA}$ (2 TTL Loads), $T_{MIN} \leq T_A \leq T_{MAX}$		0.10	0.40	V
OFF Leakage			$\pm 0.05$	1.0	$\mu A$
<b>SUPPLY CURRENT</b>					
LM231, LM231A	$V_S = 5V$	2.0	3.0	4.0	mA
	$V_S = 40V$	2.5	4.0	6.0	mA
LM331, LM331A	$V_S = 5V$	1.5	3.0	6.0	mA
	$V_S = 40V$	2.0	4.0	8.0	mA

Table 2: Electrical Characteristics for LM331

# Typical Circuit Characteristic

Nonlinearity Error as Precision V-to-F Converter (Figure 4)

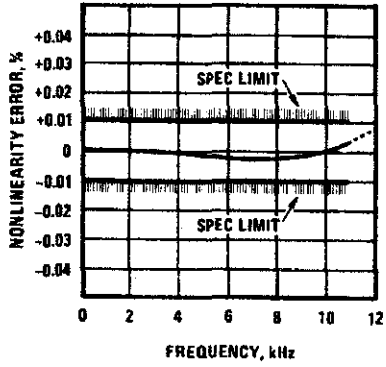

00568025

Nonlinearity Error

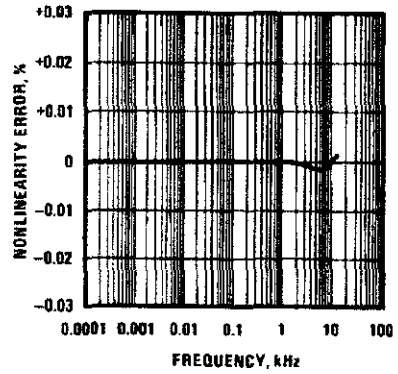

00568026

Nonlinearity Error vs. Power Supply Voltage

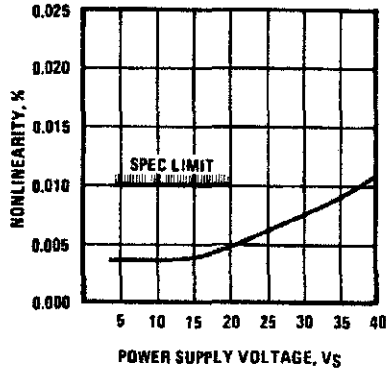

00568027

Frequency vs. Temperature

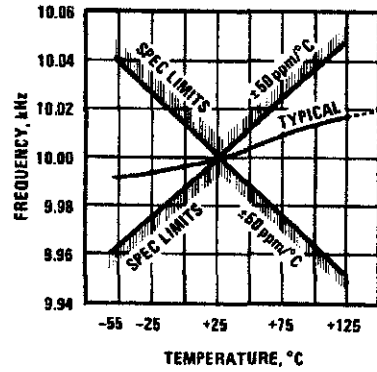

00568028

V<sub>REF</sub> vs. Temperature

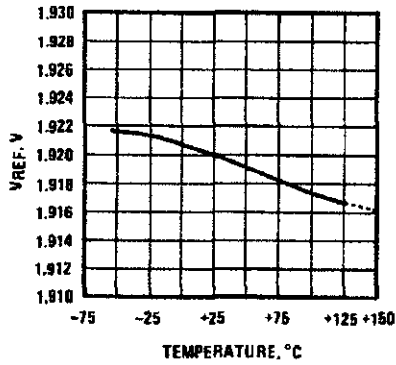

00568029

Output Frequency vs. V<sub>SUPPLY</sub>

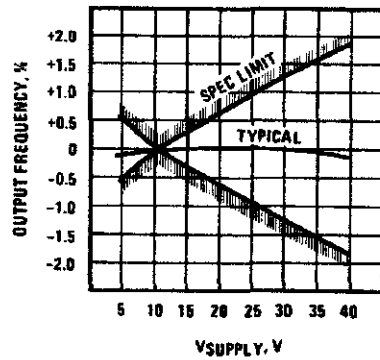

00568030



# Schematic Diagram

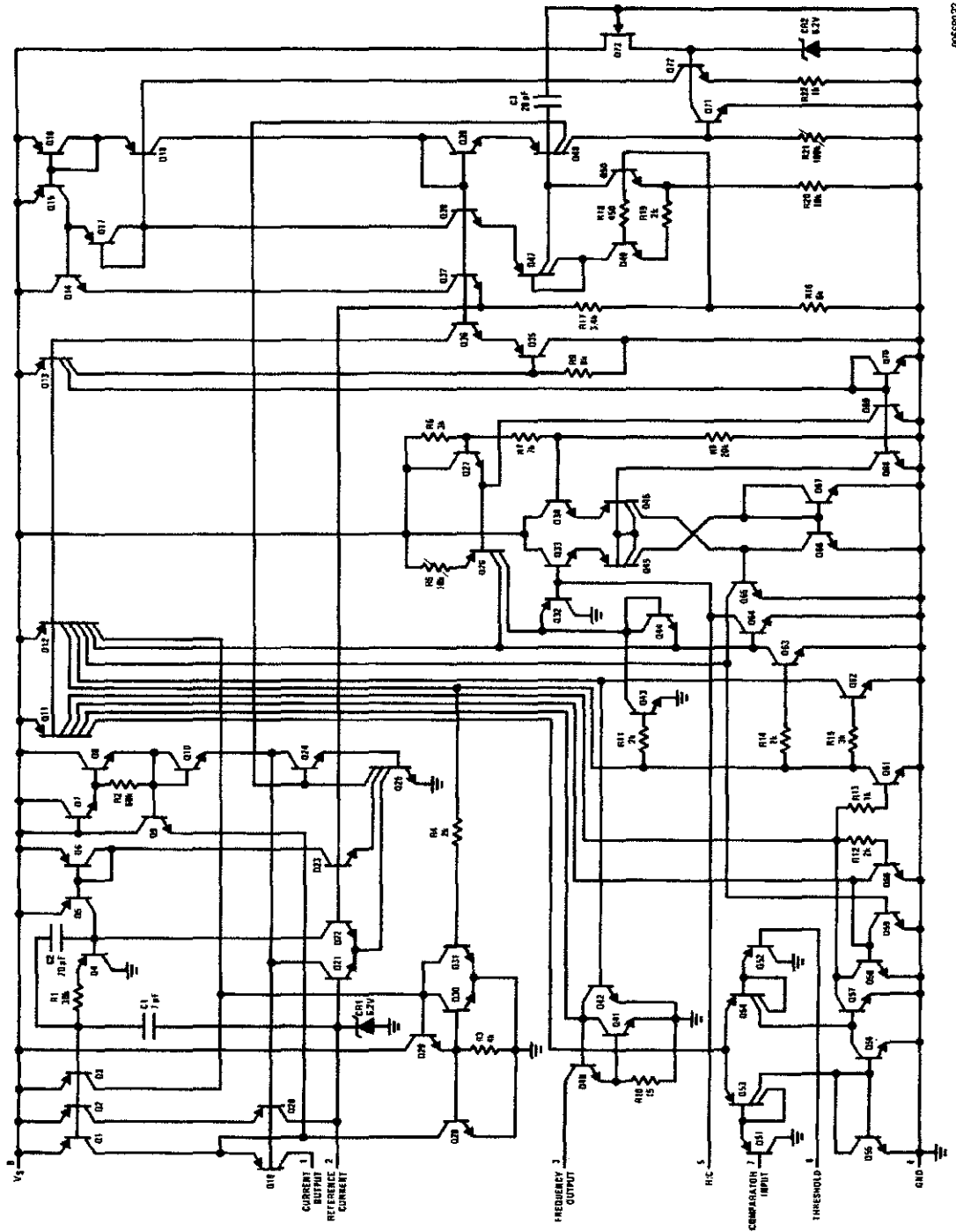

## APPENDIX C

### PRECISION CENTIGRADE TEMPERATURE SENSORS

#### General Description

The LM35 series are precision integrated-circuit temperature sensors, whose output voltage is linearly proportional to the Celsius (Centigrade) temperature. The LM35 thus has an advantage over linear temperature sensors calibrated in

° Kelvin, as the user is not required to subtract a large constant voltage from its output to obtain convenient Centigrade scaling. The LM35 does not require any external calibration or trimming to provide typical accuracies of  $\pm 1/4^{\circ}\text{C}$  at room temperature and  $\pm 3/4^{\circ}\text{C}$  over a full  $-55$  to  $+150^{\circ}\text{C}$  temperature range. Low cost is assured by trimming and calibration at the wafer level. The LM35's low output impedance, linear output, and precise inherent calibration make interfacing to readout or control circuitry especially easy. It can be used with single power supplies, or with plus and minus supplies. As it draws only  $60\ \mu\text{A}$  from its supply, it has very low self-heating, less than  $0.1^{\circ}\text{C}$  in still air. The LM35 is rated to operate over a  $-55^{\circ}$  to  $+150^{\circ}\text{C}$  temperature range, while the LM35C is rated for a  $-40^{\circ}$  to  $+110^{\circ}\text{C}$  range ( $-10^{\circ}$  with improved accuracy). The LM35 series is available packaged in hermetic TO-46 transistor packages, while the

LM35C, LM35CA, and LM35D are also available in the plastic TO-92 transistor package. The LM35D is also available in an 8-lead surface mount small outline package and a plastic TO-220 package.

#### Features

- Calibrated directly in ° Celsius (Centigrade)
- Linear + 10.0 mV/°C scale factor
- $0.5^{\circ}\text{C}$  accuracy guaranteeable (at  $+25^{\circ}\text{C}$ )
- Rated for full  $-55^{\circ}$  to  $+150^{\circ}\text{C}$  range
- Suitable for remote applications

- Low cost due to wafer-level trimming
- Operates from 4 to 30 volts
- Less than 60  $\mu$ A current drain
- Low self-heating, 0.08°C in still air
- Nonlinearity only  $\pm 1/4^\circ\text{C}$  typical
- Low impedance output, 0.1 W for 1 mA load

## Connection Diagram

**TO-46  
Metal Can Package\***

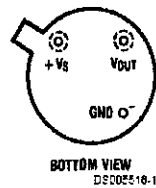

\*Case is connected to negative pin (GND)

Order Number LM35H, LM35AH, LM35CH, LM35CAH or LM35DH

See NS Package Number H03H

**SO-8  
Small Outline Molded Package**

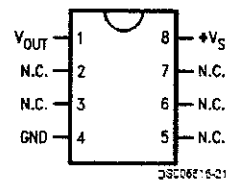

N.C. = No Connection

Order Number LM35DM  
See NS Package Number M08A

**TO-92  
Plastic Package**

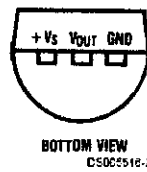

Order Number LM35CZ,  
LM35CAZ or LM35DZ  
See NS Package Number Z03A

**TO-220  
Plastic Package\***

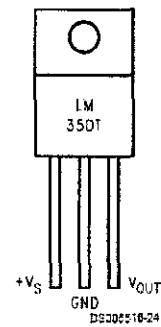

\*Tab is connected to the negative pin (GND).

Note: The LM35DT pinout is different than the discontinued LM35DP.

Order Number LM35DT  
See NS Package Number TA03F

## Electrical Characteristics

(Notes 1, 6)

Parameter	Conditions	LM35A			LM35CA			Units (Max.)
		Typical	Tested Limit (Note 4)	Design Limit (Note 5)	Typical	Tested Limit (Note 4)	Design Limit (Note 5)	
Accuracy (Note 7)	$T_A = +25^\circ\text{C}$	$\pm 0.2$	$\pm 0.5$		$\pm 0.2$	$\pm 0.5$		$^\circ\text{C}$
	$T_A = -10^\circ\text{C}$	$\pm 0.3$			$\pm 0.3$		$\pm 1.0$	$^\circ\text{C}$
	$T_A = T_{\text{MAX}}$	$\pm 0.4$	$\pm 1.0$		$\pm 0.4$	$\pm 1.0$		$^\circ\text{C}$
	$T_A = T_{\text{MIN}}$	$\pm 0.4$	$\pm 1.0$		$\pm 0.4$		$\pm 1.5$	$^\circ\text{C}$
Nonlinearity (Note 8)	$T_{\text{MIN}} \leq T_A \leq T_{\text{MAX}}$	$\pm 0.18$		$\pm 0.35$	$\pm 0.15$		$\pm 0.3$	$^\circ\text{C}$
Sensor Gain (Average Slope)	$T_{\text{MIN}} \leq T_A \leq T_{\text{MAX}}$	<b>+10.0</b>	<b>+9.9,</b> <b>+10.1</b>		<b>+10.0</b>		<b>+9.9,</b> <b>+10.1</b>	mV/ $^\circ\text{C}$
Load Regulation (Note 3) $0 \leq I_L \leq 1 \text{ mA}$	$T_A = +25^\circ\text{C}$	$\pm 0.4$	$\pm 1.0$		$\pm 0.4$	$\pm 1.0$		mV/mA
	$T_{\text{MIN}} \leq T_A \leq T_{\text{MAX}}$	$\pm 0.5$		$\pm 3.0$	$\pm 0.5$		$\pm 3.0$	mV/mA
Line Regulation (Note 3)	$T_A = +25^\circ\text{C}$	$\pm 0.01$	$\pm 0.05$		$\pm 0.01$	$\pm 0.05$		mV/V
	$4\text{V} \leq V_S \leq 30\text{V}$	$\pm 0.02$		$\pm 0.1$	$\pm 0.02$		$\pm 0.1$	mV/V
Quiescent Current (Note 9)	$V_S = +5\text{V}, +25^\circ\text{C}$	56	67		56	67		$\mu\text{A}$
	$V_S = +5\text{V}$	<b>105</b>		<b>131</b>	<b>91</b>		<b>114</b>	$\mu\text{A}$
	$V_S = +30\text{V}, +25^\circ\text{C}$	56.2	68		56.2	68		$\mu\text{A}$
	$V_S = +30\text{V}$	<b>105.5</b>		<b>133</b>	<b>91.5</b>		<b>116</b>	$\mu\text{A}$
Change of Quiescent Current (Note 3)	$4\text{V} \leq V_S \leq 30\text{V}, +25^\circ\text{C}$	0.2	1.0		0.2	1.0		$\mu\text{A}$
	$4\text{V} \leq V_S \leq 30\text{V}$	<b>0.5</b>		<b>2.0</b>	<b>0.5</b>		<b>2.0</b>	$\mu\text{A}$
Temperature Coefficient of Quiescent Current		<b>+0.39</b>		<b>+0.5</b>	<b>+0.39</b>		<b>+0.5</b>	$\mu\text{A}/^\circ\text{C}$
Minimum Temperature for Rated Accuracy	In circuit of <i>Figure 1</i> , $I_L = 0$	+1.5		+2.0	+1.5		+2.0	$^\circ\text{C}$
Long Term Stability	$T_J = T_{\text{MAX}}$ , for 1000 hours	$\pm 0.08$			$\pm 0.08$			$^\circ\text{C}$

<b>Electrical Characteristics</b>								
(Notes 1, 6)								
Parameter	Conditions	LM35			LM35C, LM35D			Units (Max.)
		Typical	Tested Limit (Note 4)	Design Limit (Note 5)	Typical	Tested Limit (Note 4)	Design Limit (Note 5)	
Accuracy, LM35, LM35C (Note 7)	$T_A = +25^\circ\text{C}$	$\pm 0.4$	$\pm 1.0$		$\pm 0.4$	$\pm 1.0$		$^\circ\text{C}$
	$T_A = -10^\circ\text{C}$	$\pm 0.5$			$\pm 0.5$		$\pm 1.5$	$^\circ\text{C}$
	$T_A = T_{\text{MAX}}$	$\pm 0.8$	$\pm 1.5$		$\pm 0.8$		$\pm 1.5$	$^\circ\text{C}$
	$T_A = T_{\text{MIN}}$	$\pm 0.8$		$\pm 1.5$	$\pm 0.8$		$\pm 2.0$	$^\circ\text{C}$
Accuracy, LM35D (Note 7)	$T_A = +25^\circ\text{C}$				$\pm 0.6$	$\pm 1.5$		$^\circ\text{C}$
	$T_A = T_{\text{MAX}}$				$\pm 0.9$		$\pm 2.0$	$^\circ\text{C}$
	$T_A = T_{\text{MIN}}$				$\pm 0.9$		$\pm 2.0$	$^\circ\text{C}$
Nonlinearity (Note 8)	$T_{\text{MIN}} \leq T_A \leq T_{\text{MAX}}$	$\pm 0.3$		$\pm 0.5$	$\pm 0.2$		$\pm 0.5$	$^\circ\text{C}$
Sensor Gain (Average Slope)	$T_{\text{MIN}} \leq T_A \leq T_{\text{MAX}}$	<b>+10.0</b>	<b>+9.8,</b> <b>+10.2</b>		<b>+10.0</b>		<b>+9.8,</b> <b>+10.2</b>	mV/ $^\circ\text{C}$
Load Regulation (Note 3) $0 \leq I_L \leq 1$ mA	$T_A = +25^\circ\text{C}$	$\pm 0.4$	$\pm 2.0$		$\pm 0.4$	$\pm 2.0$		mV/mA
	$T_{\text{MIN}} \leq T_A \leq T_{\text{MAX}}$	$\pm 0.5$		$\pm 5.0$	$\pm 0.5$		$\pm 5.0$	mV/mA
Line Regulation (Note 3)	$T_A = +25^\circ\text{C}$	$\pm 0.01$	$\pm 0.1$		$\pm 0.01$	$\pm 0.1$		mV/V
	$4\text{V} \leq V_S \leq 30\text{V}$	$\pm 0.02$		$\pm 0.2$	$\pm 0.02$		$\pm 0.2$	mV/V
Quiescent Current (Note 9)	$V_S = +5\text{V}, +25^\circ\text{C}$	56	80		56	80		$\mu\text{A}$
	$V_S = +5\text{V}$	<b>105</b>		<b>158</b>	<b>91</b>		<b>138</b>	$\mu\text{A}$
	$V_S = +30\text{V}, +25^\circ\text{C}$	56.2	82		56.2	82		$\mu\text{A}$
	$V_S = +30\text{V}$	<b>105.5</b>		<b>161</b>	<b>91.5</b>		<b>141</b>	$\mu\text{A}$
Change of Quiescent Current (Note 3)	$4\text{V} \leq V_S \leq 30\text{V}, +25^\circ\text{C}$	0.2	2.0		0.2	2.0		$\mu\text{A}$
	$4\text{V} \leq V_S \leq 30\text{V}$	<b>0.5</b>		<b>3.0</b>	<b>0.5</b>		<b>3.0</b>	$\mu\text{A}$
Temperature Coefficient of Quiescent Current		<b>+0.39</b>		<b>+0.7</b>	<b>+0.39</b>		<b>+0.7</b>	$\mu\text{A}/^\circ\text{C}$
Minimum Temperature for Rated Accuracy	In circuit of Figure 1, $I_L = 0$	+1.5		+2.0	+1.5		+2.0	$^\circ\text{C}$
Long Term Stability	$T_J = T_{\text{MAX}}$ , for 1000 hours	$\pm 0.08$			$\pm 0.08$			$^\circ\text{C}$

Table 3: Electrical Characteristics for LM35

## Typical Performance Characteristics

**Thermal Resistance  
Junction to Air**

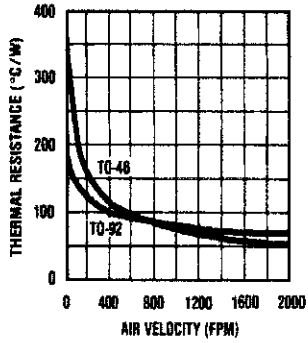

DS005616-25

**Thermal Time Constant**

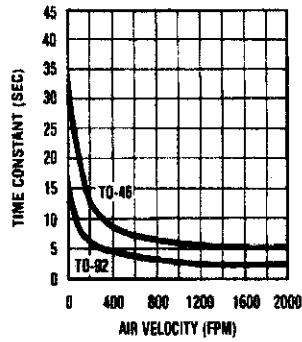

DS005616-26

**Thermal Response  
in Still Air**

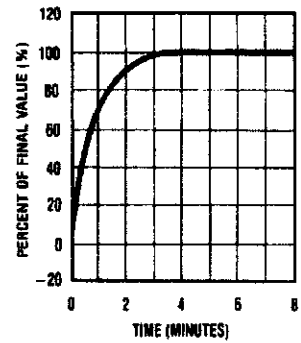

DS005616-27

**Thermal Response in  
Stirred Oil Bath**

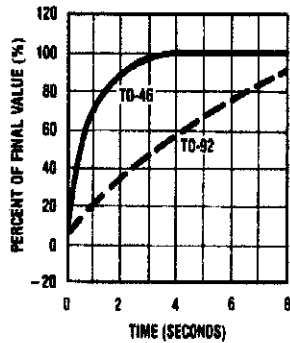

DS005616-28

**Minimum Supply  
Voltage vs. Temperature**

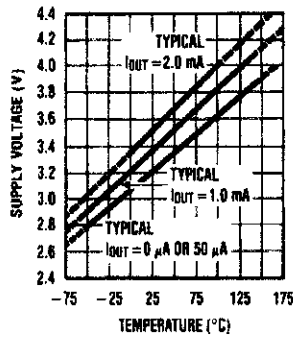

DS005616-29

**Quiescent Current  
vs. Temperature  
(In Circuit of Figure 1.)**

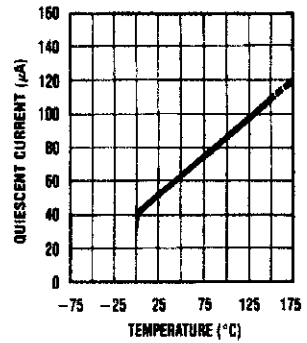

DS005616-30

**Quiescent Current  
vs. Temperature  
(In Circuit of Figure 2.)**

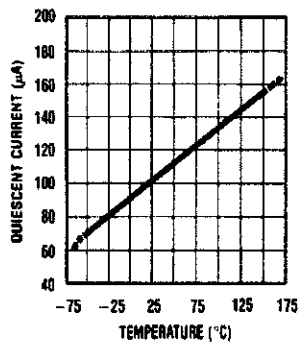

DS005616-31

**Accuracy vs. Temperature  
(Guaranteed)**

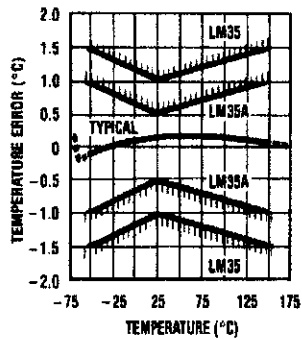

DS005616-32

**Accuracy vs. Temperature  
(Guaranteed)**

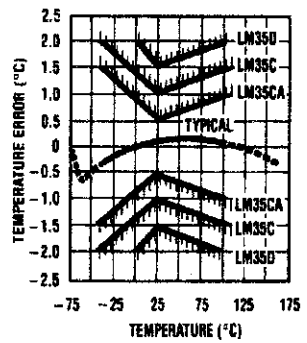

DS005616-33

## Block Diagram

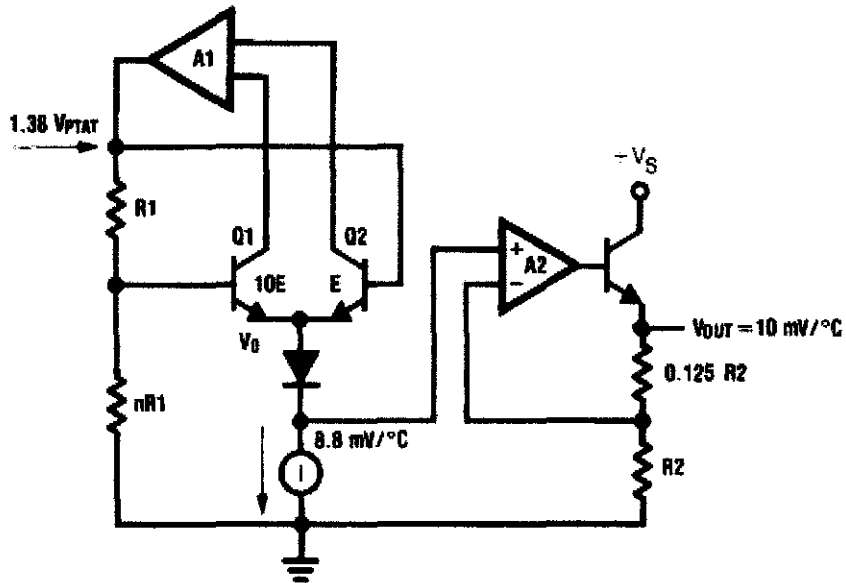

DS005516-23

## Physical Dimension

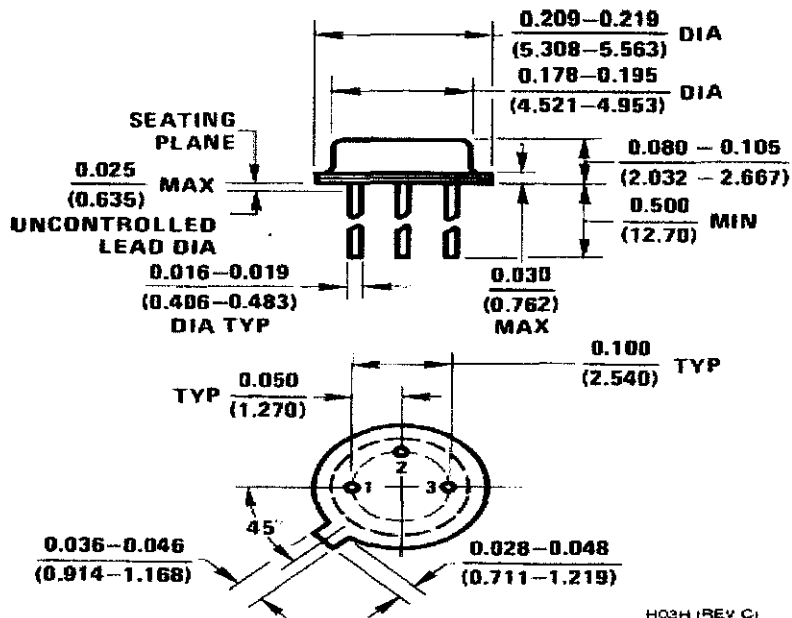

**TO-46 Metal Can Package (H)**  
**Order Number LM35H, LM35AH, LM35CH,**  
**LM35CAH, or LM35DH**  
**NS Package Number H03H**

## APPENDIX D

### QUAD 2 INPUT SCHMITT NAND GATE

#### Features

- High speed
- $T_{pd} = 11 \text{ ns (typ.)}$  At  $V_{CC} = 5 \text{ v}$  lowpower dissipation
- $I_{CC} = 1 \mu\text{a (max.)}$  At  $T_a = 25 \text{ }^\circ\text{C}$  output drive capability
- 10 lSttl loads high noise immunity
- $V_h \text{ (typ.)} = 0.9 \text{ v}$  at  $V_{CC} = 5 \text{ v}$  symmetrical output impedance
- $I_{OH} = I_{OL} = 4 \text{ ma (min.)}$  Balancedpropagation delays
- $T_{plh} = t_{phl}$  wide operating voltage range
- $V_{CC} \text{ (opr)} = 2 \text{ v to } 6 \text{ v}$  pin and function compatible with 54/74ls132

#### Description

The M54/74HC132 is a high speed CMOSQUAD2-INPUT SCHMITT NAND GATE fabricated in silicon gate C2MOS technology. It has the same high speed performance of LSTTL combined with true CMOS low power consumption. Pin configuration and function are identical to those of the M54/74HC00. The hysteresis characteristics (around 20 % VCC) of all inputs allow slowly changing input signals to be transformed into sharply defined jitter-free output signals. All inputs are equipped with protection circuits against static discharge and transient excess voltage.



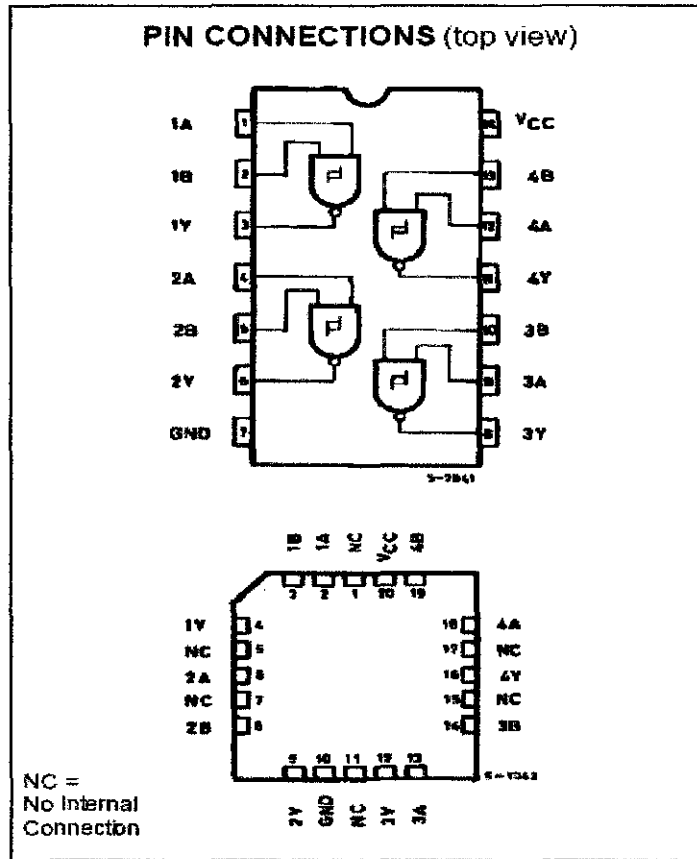

#### ABSOLUTE MAXIMUM RATINGS

Symbol	Parameter	Value	Unit
$V_{CC}$	Supply Voltage	-0.5 to +7	V
$V_I$	DC Input Voltage	-0.5 to $V_{CC} + 0.5$	V
$V_O$	DC Output Voltage	-0.5 to $V_{CC} + 0.5$	V
$I_{IK}$	DC input Diode Current	$\pm 20$	mA
$I_{OK}$	DC Output Diode Current	$\pm 20$	mA
$I_C$	DC Output Source Sink Current Per Output Pin	$\pm 25$	mA
$I_{CC}$ or $I_{GND}$	DC $V_{CC}$ or Ground Current	$\pm 50$	mA
$P_D$	Power Dissipation	500 (*)	mW
$T_{Sg}$	Storage Temperature	-65 to +150	$^{\circ}C$
$T_L$	Lead Temperature (10 sec)	300	$^{\circ}C$

Absolute Maximum Ratings are those values beyond which damage to the device may occur. Functional operation under these conditions is not implied.  
 (\*) 500 mW:  $\pm 65^{\circ}C$  derate to 300 mW by 10mW/ $^{\circ}C$ : 65  $^{\circ}C$  to 85  $^{\circ}C$

Table 4: Absolute Maximum Rating for NAND Gate