

# **WIRELESS ELECTROMYOGRAPH RECORDER**

**By**

**Wan Nur Syazwani bt Wan Zin**

**Dissertation submitted in partial fulfilment of  
the requirements for the  
Bachelor of Engineering (Hons)  
(Electrical & Electronic Engineering)**

**SEPTEMBER 2011**

**Universiti Teknologi PETRONAS  
Bandar Seri Iskandar  
31750 Tronoh  
Perak Darul Ridzuan**

# **CERTIFICATION OF APPROVAL**

## **WIRELESS ELECTROMYOGRAPH RECORDER**

By

Wan Nur Syazwani bt Wan Zin

A project dissertation submitted to the  
Electrical & Electronic Engineering Department  
Universiti Teknologi PETRONAS  
in partial fulfilment of the requirements for the  
Bachelor of Engineering (Hons)  
(Electrical & Electronic Engineering)

Approved by,

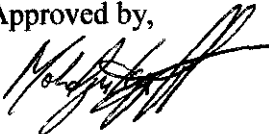

(Dr. Mohd Zuki bin Yusoff)  
Project Supervisor

Universiti Teknologi PETRONAS  
Tronoh, Perak

September 2011

## **CERTIFICATION OF ORIGINALITY**

This is to certify that I am responsible for the work submitted in this project, that the original work is my own except as specified in the references and acknowledgements, and that the original work contained herein has not been undertaken or performed by unspecified sources or persons.



---

WAN NUR SYAZWANI BT WAN ZIN

## **ACKNOWLEDGEMENTS**

First and foremost, I would like to express my heartily gratitude to my supervisor, Dr. Mohd Zuki bin Yusoff for the guidance, encouragement, and enthusiasm given throughout the progress of this report.

My appreciation also goes to my beloved parents and family who have been so tolerant and supports me all these years. Thanks for their encouragements, love and emotional supports that they have given to me.

Nevertheless, my great appreciation is dedicated to all my friends and those who are involved directly or indirectly with this project. Thank you.

## **ABSTRACT**

Muscles generate low voltages which are around 100 mV when they contract. These voltages are weakened by internal tissues and the skin. Even though the voltages are weak but they can be measurable at the surface of the skin. Electromyography (EMG) recorder is used to measure a muscle electrical activity that occurs during muscle contraction and relaxation cycles. In medical applications, people mostly used a wired EMG recorder. However, the advanced technology had allowed wireless collection and recording of muscle electrical activities using an EMG recorder. Thus this report is going to discuss in depth about a wireless EMG recorder. This project background study will include problem statements to justify the need of this project, objectives, scope and limitation of the project as well as project feasibility. Literature reviews will also cover aspects like EMG signal, conventional EMG recorder, and types of wireless network that can be used. In the methodology part, the proposed design, tool and equipment will be discussed further. Result and discussion will explain about the output obtained from the project. This report will be wrapped up with a conclusion.

## TABLE OF CONTENTS

<b>CERTIFICATION OF APPROVAL</b> .....	III
<b>CERTIFICATION OF ORIGINALITY</b> .....	IV
<b>ACKNOWLEDGEMENT</b> .....	V
<b>ABSTRACT</b> .....	VI
<b>LIST OF FIGURES</b> .....	IX
<b>LIST OF EQUATIONS</b> .....	X
<b>CHAPTER 1 PROJECT BACKGROUND</b> .....	1
1.1 Background Study.....	1
1.2 Problem Statement .....	2
1.3 Objectives .....	2
<b>CHAPTER 2 LITERATURE REVIEW</b> .....	3
2.1 EMG signals.....	3
2.2 Conventional EMG recorder .....	4
2.2.1 Electrodes.....	4
2.2.2 Amplifier.....	5
2.2.3 Filter.....	6
2.2.4 Analog to Digital Converter.....	6
2.2.5 Processor/monitor.....	7
2.3 Wireless Network.....	7
2.3.1 Types of Wireless Network in Medical Applications.....	7
2.3.2 Wireless Network Standards.....	9
2.3.2 Comparison of the ways to create wireless communication.....	9
<b>CHAPTER 3 METHODOLOGY</b> .....	11
3.1 System Overview .....	12
3.2 Tools & Equipment.....	12
3.2.1 Hardware.....	12
3.2.2 Software.....	19

<b>CHAPTER 4 RESULT &amp; DISCUSSION</b> .....	20
4.1 Amplifier, Filter & Rectifier Circuit.....	20
4.2 Wireless Transmission Circuit.....	21
<b>CHAPTER 5 CONCLUSION</b> .....	26
<b>REFERENCES</b> .....	27
<b>APPENDICES</b> .....	29
Appendix A: PIC18F452 Pinout I/O Description.....	29
Appendix B: Datasheets for RF wireless module.....	34
Appendix C: RF Transmitter and Receiver firmware files.....	41

<b>LIST OF FIGURES</b>	<b>PAGE</b>
Figure 1: ZeroWire system	1
Figure 2: Three time domain EMG signals	3
Figure 3: Operation flow of conventional EMG recorder	4
Figure 4: Typical Ag/AgCl Electrodes	4
Figure 5: The placement of two EMG electrodes	5
Figure 6: Wireless EMG system	11
Figure 7: MEDI -TRACE™ Series Foam Electrodes	12
Figure 8: INA106 configuration	12
Figure 9: TL072 pin configuration	13
Figure 10: Active high pass filter	14
Figure 11: Active low-pass filter	15
Figure 12: Active full-wave rectifier	15
Figure 13: PIC18F452 controller	17
Figure 14: FM-RTFQ2-433R transmitter circuit	18
Figure 15: FM-RRFQ2-433 receiver circuit	18
Figure 16: Transmitter pin configuration	18
Figure 17: Receiver pin configuration	18
Figure 18: Schematic circuit for amplifier	20
Figure 19: Schematic circuit for filter and rectifier	20
Figure 20: Circuit for amplifier, filter and rectifier	21
Figure 21: Schematic of Transmitter part	23
Figure 22: Schematic of Receiver part	23
Figure 23: Output signal of RF transmitter	24
Figure 24: Output signal of RF receiver	24
Figure 25: Output signal of RF receiver and transmitter	25



<b>LIST OF EQUATIONS</b>	<b>PAGE</b>
Equation 1: Gain of Differential Amplifier	13
Equation 2: Gain of Inverting Amplifier	14
Equation 3: Cut off frequency of active high pass filter	14
Equation 4: Cut off frequency for active low-pass filter	15
Equation 5: Voltage, V	16
Equation 6: Output voltage, $V_o$	16

## CHAPTER 1: PROJECT BACKGROUND

### 1.1 Background Study

Since Emil du Bois-Reymond [1] discovered the nerve potential and electrical properties of biological cells and tissues, electromyography system has evolved rapidly for THE past hundreds of years. It started from analog EMG system, digital EMG system, microprocessor-controlled EMG system, PC-based EMG system and the most recent one are handheld and wireless EMG system such as the ZeroWire system [2] that was manufactured by Aurion shown in Figure 1.



Figure 1: ZeroWire system

Recent developments in all fields of electronic technologies have pushed EMG equipment into the present state. Wireless technologies such as Wi-Fi and Bluetooth have also been incorporated into today's existing EMG equipment to provide the user with extended mobility. Acquired EMG signals can now be picked up on the body and sent wirelessly to the personal computer (PC) where it is recorded, processed and analyzed. These features give many advantages to the users especially the patient, doctors, physician and others.

## **1.2 Problem Statement**

Conventional electromyography equipment has few disadvantages which are:

- 1) The sensor electrodes are wired to the associated amplifier and display equipment which cause the users to suffer from the inconvenience of carrying many cabled electrodes [3].
- 2) Wire cables are subject to triboelectric phenomena whereby small electrode potentials are caused by physical movement of the signal carrying electrical cable [4]. Thus, the signal recorded could be not so accurate.
- 3) Besides, patient leakage current which is defined as the current flowing from a part applied to a patient to ground that originates from the accidental emergence of voltage from an external source on the patient may occur when using 240V DC equipment [5].

## **1.3 Objectives**

The main objective of this project is to build a wireless EMG recorder. Other objectives are:

- 1) To apply the wireless module for signal transmission
- 2) To perform analysis on the EMG signals
- 3) To explore the function of MATLAB in recording and processing signals

## **1.4 Scope of Project**

The scope of this project consists of research, prototype construction, testing, analysis and improvements. The research is important for better understanding on the theory and concept of a wireless electromyography recorder. After that, the concept will be applied to design and build the prototype. Then, testing must be done to the prototype in order to make sure it is working well. Furthermore, analysis of the result and improvements are included in the scope of this project.

## CHAPTER 2: LITERATURE REVIEW

### 2.1 EMG Signals

EMG signals are basically made up of superimposed motor unit action potentials (MUAPs) from several motor units. For an in-depth analysis, the measured EMG signals can be decomposed into their constituent MUAPs. MUAPs from different motor units would show different characteristic shapes, while MUAPs recorded from the same motor unit are typically alike. The shapes of the MUAPs are important in conveying information about the characteristics and arrangement of the muscle fibers. Figure 2 shows three time domain signals namely the EMG signal which is made up of individual motor neuron action potentials, a rectified signal which looks similar to the EMG signal but all values are positive, and a signal representing the cumulative sum of the rectified signal reset to every 50 samples.

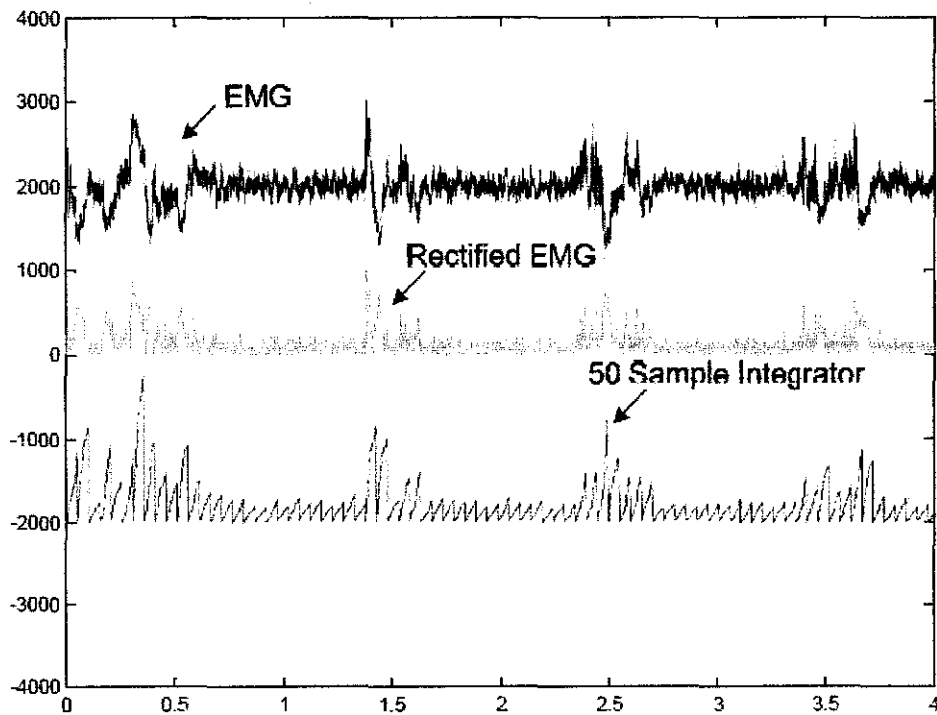

Figure 2: Three time domain EMG signals

## 2.2 Conventional EMG Recorder

Basic operation of a conventional EMG recorder starts when the EMG signal generated by the muscle fibers is captured by the electrodes, then amplified and filtered before being converted to a digital signal by the encoder. It is then sent to the computer to be processed, displayed and recorded by plotter software [7]. Figure 3 shows the operation flow of conventional EMG recorder.

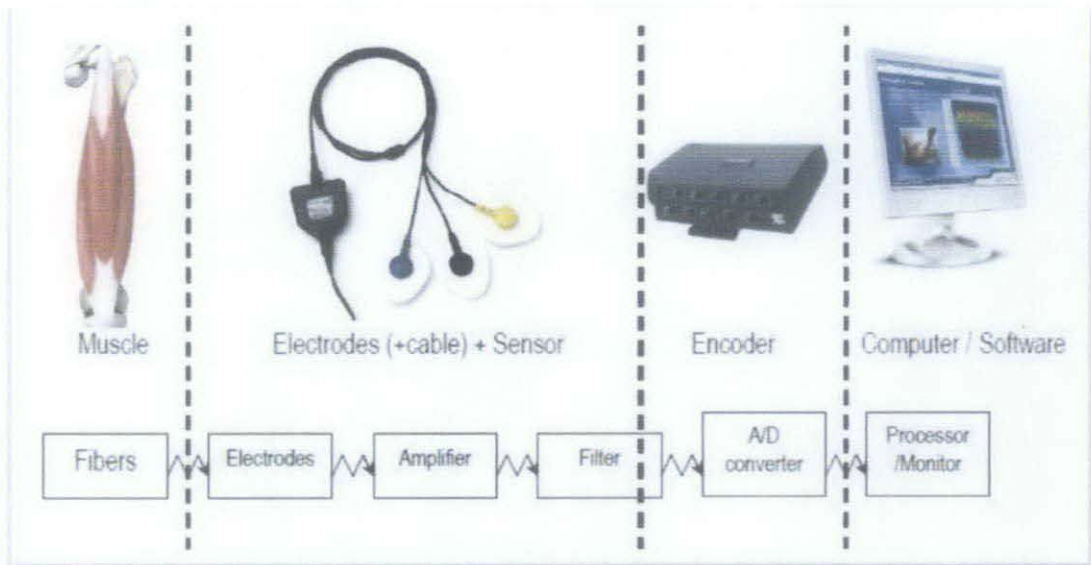

Figure 3: Operation flow of conventional EMG recorder

### 2.2.1 Electrodes

Usually, Ag-AgCl electrodes are used in over 80% of surface EMG applications. Figure 4 shows typical Ag/AgCl electrodes.

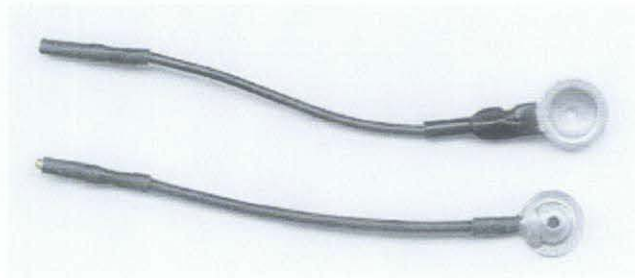

Figure 4: Typical Ag/AgCl Electrodes

Silver - silver-chloride (Ag- AgCl) is the most common composite for the metallic part of gelled electrodes. The AgCl layer allows current from the muscle to pass more freely across the junction between the electrolyte and the electrode. This introduces less electrical noise into the measurement, as compared with equivalent metallic electrodes. [8]. An EMG signal is collected by using a surface EMG electrode placed on the skin of the muscle of interest. Figure 4 shows the placement of two EMG electrodes on the biceps and one for the reference. Reference electrode is placed on the wrist, which is the bony area of hand. This wrist is chosen because fewer muscles contained at this area will not generate EMG signal. Before placing the electrode, the subject skin is cleaned to reduce the resistance of the outer layer of the skin and ensure a good electrical contact. The distance between the two electrodes is 2 to 5 cm apart and aligned with the long axis marked on the skin overlaying the belly of the biceps muscle [9].

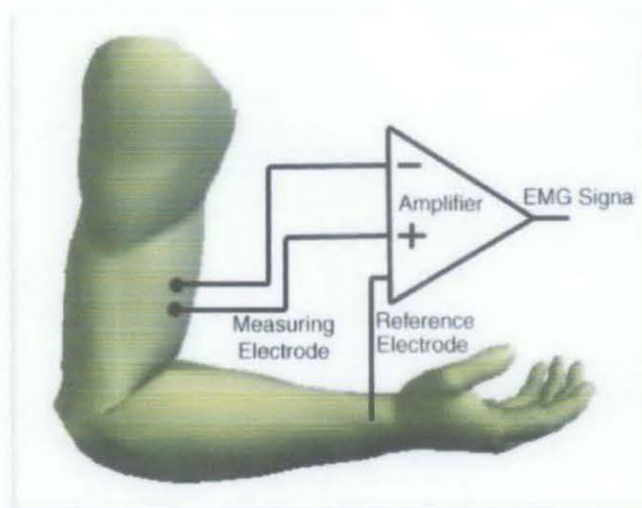

Figure 5: The placement of two EMG electrodes

### 2.2.2 *Amplifier*

An amplifier is also necessary to optimize the resolution of the recording or digitizing equipment [10]. Amplifiers of high quality have adjustable gains of between, at least, 100 and 10 000 to maximize the signal to noise ratio of the EMG signal during each recording. This range of gains provides the sufficient range of amplifications for surface EMG signals which can range typically from 0 to 6mV peak to peak.

While there may be several stages of amplification, the most important stage is often described as pre-amplification. Pre-amplification implies the first stage of amplification, close to the signal source. There are several important properties to consider in a pre-amplifier:

- High common mode rejection ratio
- Very high input impedance
- Short distance to the signal source
- Strong DC signal suppression

### 2.2.3 *Filter*

Basically, there are three types of filters applied to EMG data: high-pass, low-pass, and notch filters [11]. A low-pass filter is used in order to allow signal frequencies below the low cut-off frequency to pass and stops frequencies above the cut-off frequency. This type of filter is commonly used to help reduce environmental noise and provide a smoother signal. For a high-pass filter, it allows frequencies higher than the cut-off frequency to pass and removes any steady direct current (DC) component or slow fluctuations from the signal [12]. A notch filter removes a particular frequency from a signal and has a frequency response that falls to zero over a narrow range of frequencies (i.e. a 50 Hz notch may block signals from 49.5 – 50.5 Hz).

### 2.2.4 *Analog-to-Digital converter*

The digitization process of an analog signal is performed by a device known as an Analog-to-Digital Converter (ADC) [13]. The following ADC characteristics should be considered:

- ADC Range Setting
- Gain Setting
- Minimum Resolution

### **2.2.5 Processor/monitor**

At the processor of the computer, the EMG signal will be recorded by using certain software and the signal graph will be displayed on the monitor. After the recording, the signal characteristics will be processed for further analysis.

## **2.3 Wireless Network**

Wireless networks based technologies has facilitated biomedical researches for several decades and has been applied to convey bioelectric potentials like electrocardiograms (ECG), electromyograms (EMG), or electroencephalograms (EEG) [14]. Some benefits of using wireless networks based technologies in include:

- Non-invasive monitoring
- Cost saving and efficient method of care
- Ease of communication between care givers and patients

### **2.3.1 Types of wireless network in medical applications**

There are various types of wireless network that are being applied in medical applications such as in [15]:

#### **1) WBAN (Wireless Body Area Network)**

These Body Area Networks (BANs) have extremely low power requirements which make them fit for integrating them in day to day wearables. In the medical application field, these unobtrusive devices can be attached to patient's bodies to collect vital health information such as ECG, blood pressures, etc. When used inside hospitals, BANs can be used to monitor patients in critical conditions. Outside the hospital, i.e., homecare, patients' vital signs can be collected and transmitted over the Internet to their doctors and nurses in real time.



## **2) RFID (Radio Frequency Identification)**

RFID tags are used in hospitals to keep track of equipment. They can also be planted on patients as well as doctors to know at time where they are. RFIDs are extremely low powered radio devices that do not need any battery power.

## **3) WPAN (Wireless Personal Area Network)**

WPANS using 802.15.4 or Bluetooth have potential uses in the medical fields. These are short range networks that can be deployed for example, within a patient's room. Nurses are able to monitor patients in real time without having to visit them frequently. These saves them time and give them the opportunity to take care of more patients. Bluetooth is also a good technology for short range communication.

## **4) Sensor Networks**

Sensor Networks technologies such as Zigbee are being combined with WBANs to form smaller scale networks that can be placed on human clothing (or other objects) and provide unobtrusive access to their health information. Due to lower power requirements, they can be deployed for a long period of time. Due to limited range and low price, sensor networks also are deployed in large numbers and thus form a distributed network covering a large portion of space.

## **5) GPRS/UMTS**

GPRS and UMTS wireless technologies have also found their uses in the area of medical applications. An application called MobiHealth, had been designed by using BANs with GPRS/UMTS for Internet connectivity.

## **6) Wireless LAN (802.11)**

Most hospitals, universities and corporate offices these days provide wireless LAN access. Some benefits include untethered access to the Internet. Hospitals can use the wireless LAN channels to transfer patient data around the hospital. Communication between medical devices is also made possible using this wireless channel.

### **2.3.2 *Wireless network standards***

Although the area of wireless networks for medical applications is largely without standards due to companies developing products based on their own standards, some standards do exist as listed below. Recently there are increasing demands for creating strict standards, especially for pacemakers, which are being used by a large number of heart patients across America [15].

- IEEE Standards Medical Device Communications/Health Informatics Standards Subscription
- ISO/IEEE Health informatics - Point-of-care medical device communication
- IEEE Standard for Medical Device Communications-Transport Profile
- Mobile Health Care Alliance
- Setting standards for mobile health information systems
- Medical Implant Communications Service in the 402-405 MHz band
- High-speed, ultra-low power, non-voice transmissions to and from implanted medical devices such as cardiac pacemakers and defibrillators.

### **2.3.3 *Comparison of the ways to create wireless communication***

There are plenty of other options to create wireless communication or even small networks of devices and applications [16]. Here is the comparison of some of the ways to create wireless communication between two or more devices:

#### **i) XBee**

**Advantages:** No collision of messages; very specific addressing of messages; can be extremely long range, fast.

**Disadvantages:** Slightly expensive; sometimes difficult to configure.

#### **ii) Wireless Internet**

**Advantages:** No collisions of messages; very specific addressing of messages; allows sending many different kinds of data; fast.

**Disadvantages:** Expensive; difficult to configure communication between another

computer and a wireless card; depending on the network and router; limited to range of wireless network.

iii) Cellphone

Advantages: Range unlimited; no collisions of messages; very specific addressing of messages.

Disadvantages: Requires either a SIM card with an account or prepaid credits; difficult to configure with the Arduino; can be relatively slow; expensive; high power requirements.

iv) Bluetooth

Advantages: Allows large amounts of data; comparatively fast; does not require much power.

Disadvantages: Difficult to configure; expensive.

v) Radio

Advantages: Cheap; easy to configure; requires little power.

Disadvantages: Cannot have more than one transmitter in an area; no addressing of messages; range limited; comparatively slow.

## CHAPTER 3: METHODOLOGY

### 3.1 System overview

Two surface EMG electrodes which are placed on the muscle tissue on the body will send the signal to the amplifier circuit. After the signal is amplified, it will go through a filter circuit in order to remove noise. The signal is then digitized using an Analog-to-Digital Converter (ADC). A wireless transmitter then transmits the recorded EMG signal to a wireless receiver circuit over wireless medium. At final stage, the data are sent to a personal computer via a USB connection that processes the digitized signal. The structure of the wireless EMG system is shown in Figure 6.

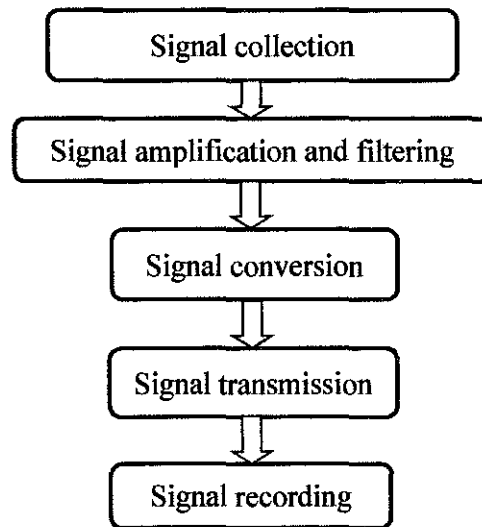

Figure 6: Wireless EMG system

## 3.2 Tools and Equipments

### 3.2.1 Hardware

#### 1) Surface EMG electrodes

In this project, as shown in Figure 7, MEDI-TRACE™ Series Foam Electrodes will be used since it has a smaller, teardrop shape footprint for convenient lead placement on small or pediatric patients [17]. The low profile foam substrate is fluid and tear resistant. The patented conductive adhesive hydrogel maximizes adhesion and electrical contact.



Figure 7: MEDI -TRACE™ Series Foam Electrodes

#### 2) Amplifier

The acquired EMG signal from the electrode is fed into an amplification stage. In the amplification stage, the acquired EMG signal is amplified by two different amplifiers. A differential amplifier is used with a gain of 110 as the first amplification and an inverting amplifier with a gain of -15 is used for the second amplification. The INA106 (shown in Figure 8) is a differential amplifier which will measure and amplify the very small voltage differences between the two electrodes placed on the muscle.

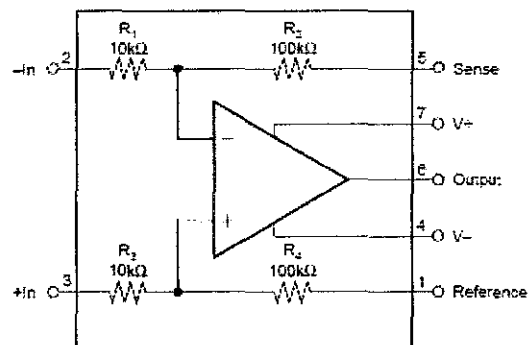
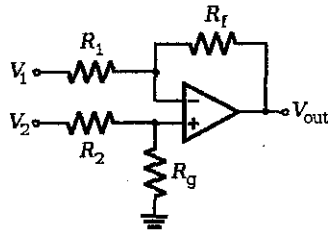

Figure 8: INA106 configuration

To produce gain of 110, a INA106 and  $1\text{M}\Omega$  resistor is used. The calculation for the gain of the differential amplifier is shown in Equation 1 as below:



$$\begin{aligned}
 A &= R_f/R_1 = R_g/R_2 \\
 &= (100\text{k} + 1\text{M})/10\text{k} \\
 &= 110\text{dB}
 \end{aligned}
 \tag{1}$$

where  $R_f = R_g = 100\text{k} + 1\text{M} = 1.1\text{M}\Omega$ ,  $R_1 = R_2 = 10\text{k}\Omega$

The TL072 chip (as shown in Figure 9) is a low noise JFET-input operational amplifier which is be used to build an inverting amplifier, active high pass filter, full wave rectifier and active low pass filter in this system.

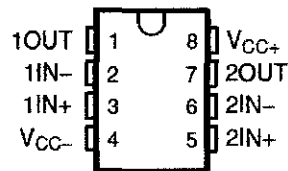
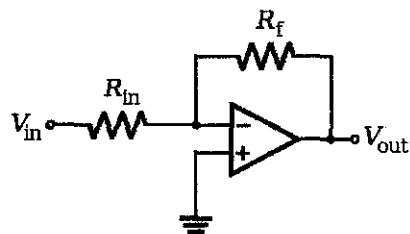

Figure 9: TL072 pin configuration

To produce gain of -15,  $150\text{k}\Omega$  and  $10\text{k}\Omega$  resistors are used. The calculation of gain of the inverting amplifier is shown in Equation 2 as below:



$$\begin{aligned}
 A &= -R_f / R_{in} \\
 &= -150\text{k} / 10\text{k} \\
 &= -15\text{dB}
 \end{aligned}
 \tag{2}$$

where  $R_f = 150\text{k}\Omega$ ,  $R_{in} = 10\text{k}\Omega$

### 3) Filter and rectifier

A filter is used to eliminate the noise contained in the signal after the signal is amplified. In this system, an operational amplifier that was included in the TL072 chip is used for building high pass filter, low pass filter and rectifier.

An active high pass filter (as shown in Figure 10) with 106Hz cut off frequency is used to get rid of any DC offset and low frequency noise.

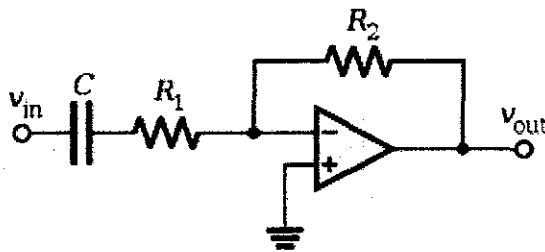

Figure 10: Active high pass filter

To produce 106Hz cut off frequency, two 150kΩ resistors and a 0.01μF capacitor are used. The calculation of the cut off frequency of active high pass filter is shown in Equation 3 as below:

$$\begin{aligned} f_c &= \frac{1}{2\pi R_1 C} \\ &= \frac{1}{2\pi(150k)(0.01\mu)} \\ &= 106\text{Hz} \end{aligned} \quad (3)$$

where  $R_1 = R_2 = 150\text{k}\Omega$ ,  $C = 0.01\mu\text{F}$

An active low-pass filter (as shown in Figure 11) is designed to filter out the humps of the signal in order to produce a smooth signal. The cut off frequency for this filter is 1.9Hz.

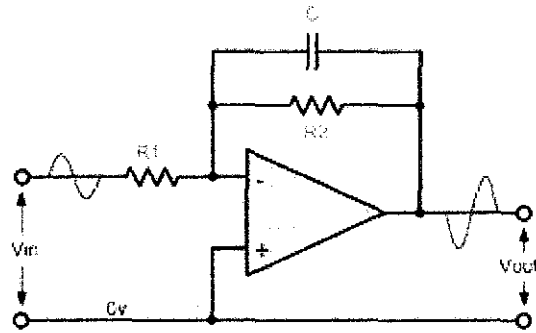

Figure 11: Active low-pass filter

The calculation of the cut off frequency for an active low-pass filter is shown in Equation 4 as below:

$$\begin{aligned}
 f_c &= \frac{1}{2\pi R_2 C} \\
 &= \frac{1}{2\pi(82k)(1.0\mu)} \\
 &= 1.9 \text{ Hz}
 \end{aligned}
 \tag{4}$$

where  $R_1 = R_2 = 82k\Omega$ ,  $C = 1.0\mu\text{F}$

The amplified and filtered signal will then be rectified using an active full-wave rectifier [19] as shown in Figure 12. The rectifier will take the negative portion of our signal and turn it positive so the entire signal falls within the positive voltage region.

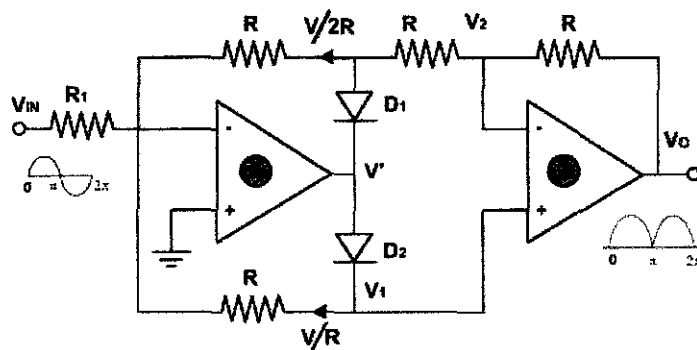

Figure 12: Active full-wave rectifier

When  $V_{in}$  is positive then  $V' =$  negative,  $D_1$  is ON and  $D_2$  is virtual ground at the input to (1). Because  $D_2$  is non-conducting, and since there is no current in the R which is



connected to the non-inverting input to (2), therefore,  $V_1 = 0$ . Hence, the system consists of two operational amplifiers in cascade with the gain of  $A_1$  equal to  $(-R / R_1)$  and the gain of  $A_2$  equal to  $(-R / R) = -1$ .

The resultant voltage output is  $V_o = (R / R_1) v_{in} > 0$  (for  $v_{in} > 0$  voltage output of (1)).

Consider now next half cycle when  $V_{in}$  is negative. The  $v'$  is positive  $D_1$  is OFF and  $D_2$  is ON because of the virtually ground at the input to (2)  $V_2 = V_1 = V$ . Since the input terminals of (2) are at the same (ground) potential, the current coming to the inverting terminal of (1) is as indicated in Figure 12.

The output voltage is  $V_o = i R + v$  where  $i = V / 2R$  (because input impedance of OPAMP is very high). Equation 5 shows the formula used in order to find  $V$  value.

$$V = -\frac{2}{3} \frac{R}{R_1} V_{in} \quad (5)$$

The sign of  $V_o$  in Equation 6 is again positive because  $V_{in}$  is negative in this half cycle. Therefore, outputs during two half cycles are the same; and full wave rectified output voltage is obtained as shown in Figure 12.

$$V_o = \frac{V}{2R} * R + V = \frac{3}{2} V = -\frac{R}{R_1} V_{in} \quad (6)$$

where  $R = R_1 = 10k\Omega$ ,  $D1 = D2 = 1N4148$

Another inverting amplifier circuit with a trimmer configured as a variable resistor is used in order to invert the signal one more time. By using a screw driver and turning the trimmer, gain of the signal can be adjusted to account for different signal strengths from different muscle groups.

#### 4) Analog to Digital Converter (ADC)

The filtered signal is fed into an analog-to-digital converter (ADC) which reads the analog signal and converts it to digital signal. The ADC is used because RF wireless module cannot receive analog data straight away.

#### 5) PIC18F452 controller

The digitized signal is processed by the PIC18F452 controller (shown in Figure 13) through suitable coding and then transmission using RF wireless module. The PIC18F452 Pinout I/O descriptions is shown in Appendix A.

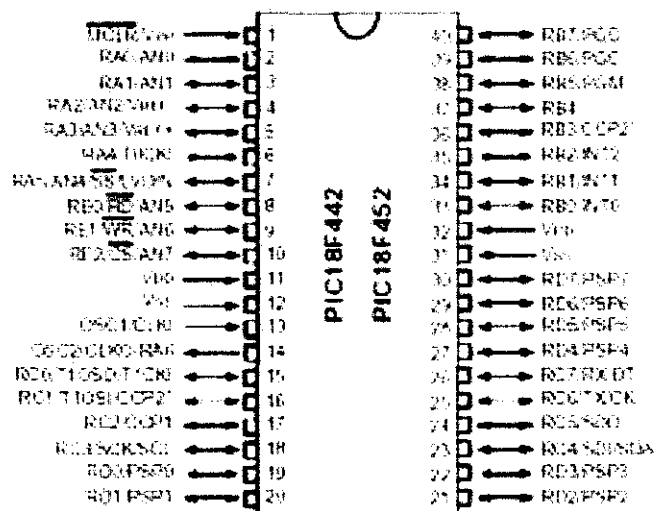

Figure 13: PIC18F452 controller

#### 6) RF wireless module

The output of the PIC18F452 is given as the input to the RF transmitter. The FM-RTFQ2-433R transmitter and FM-RRFQ2-433 receiver circuits are used for transmission of EMG signal as shown in Figure 14 and Figure 15. The frequency range of the RF transmitter and the receiver is 433.92MHz. The transmitter and receiver pair enables the simple implementation of a data link at distances up to 75 metres in-building and 250 metres in open ground. The modulation technique used is frequency modulation (FM). The data rate of the modules could be up to 9.6kbps. The maximum supply

voltage for the transmitter is 12V and for the receiver is 5V. The datasheet of these RF modules is shown in Appendix B.

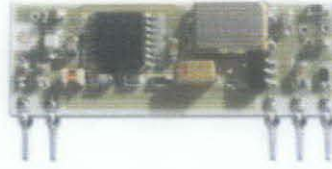

Figure 14: FM-RTFQ2-433R transmitter circuit

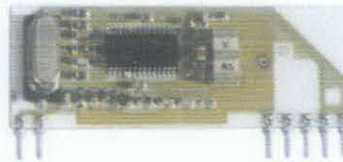

Figure 15: RF receiver circuit

The transmitter module has five pins as shown in Figure 16 below. Starting from left, Pin 1 and Pin 4 go to ground. Pin 5 is the data input from the microcontroller. Pin 3 is the supply voltage, which will commonly be 5 volts. Finally Pin 2 is the optional antenna.

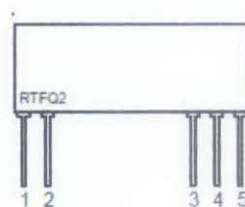

Figure 16: Transmitter pin configuration

The receiver module has 6 pins as shown in Figure 17 below. Pin 2 and Pin 15 go to ground. Pin 1 receives the incoming byte from the transmitter and Pin 18 sends the incoming byte out to the microcontroller. Pin 3 needs no connection, but can be taken to ground. Pin 14 represents Received Signal Strength Output which can be used as an indicator for the received signal strength. Pin 16 goes to supply voltage. Pin 17 goes to the AF output.

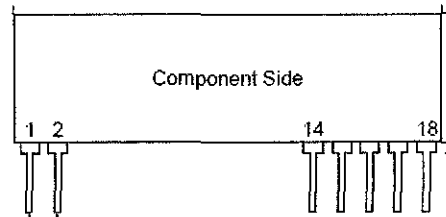

Figure 17: Receiver pin configuration

## 7) Computer

At the processor of the computer, the EMG signal will be recorded by using MATLAB software and the signal graph will be displayed on the monitor. After the recording, the signal characteristics will be processed for further application.

### 3.2.2 Software

#### 1) MATLAB Software

MATLAB<sup>®</sup> is a high-level technical computing language and interactive environment for algorithm development, data visualization, data analysis, and numeric computation. MATLAB can be used in a wide range of applications, including signal and image processing, communications, control design, test and measurement, financial modeling and analysis, and computational biology [20]. The collections of special-purpose MATLAB functions which are known as add-on toolboxes extend the MATLAB environment to solve particular classes of problems in these application areas.

## CHAPTER 4: RESULTS AND DISCUSSION

### 4.1 Amplifier, Filter and Rectifier Circuit

The prototype for amplifier, filter and rectifier discussed in the Methodology chapter are built based on the schematics in Figure 18 and Figure 19.

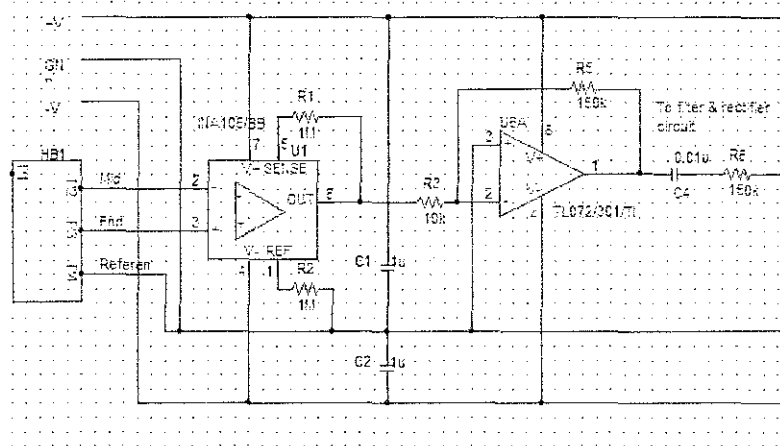

Figure 18: Schematic for amplifier

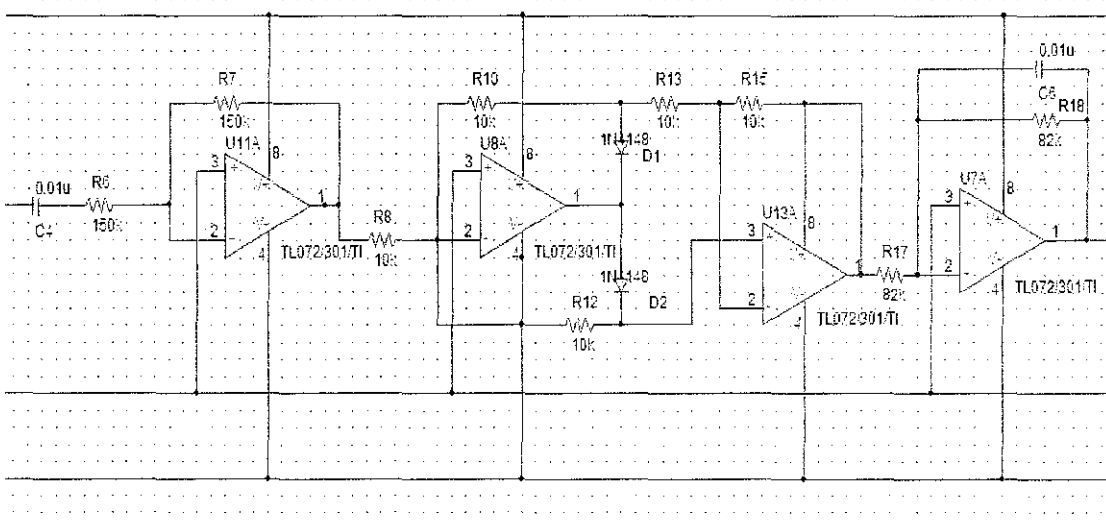

Figure 19: Schematic for filter and rectifier

The circuits in Figure 18 and 19 are built on the breadboard as shown in Figure 20. The circuit uses positive and negative power supply by connecting two 9V batteries in series.

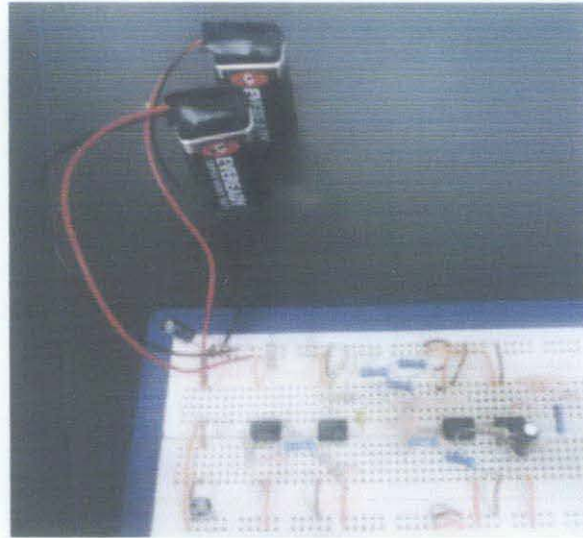

Figure 20: Circuit for amplifier, filter and rectifier

This circuit was tested with analog oscilloscope but the output signal produces some noise. This problem may be solved by inserting a higher value of a variable resistor to adjust the noise.

## 4.2 Wireless Transmission Circuit

### 4.2.1 Components

Few important components that are used in wireless transmission circuit are:

i. Two PICs 18F452

These two microcontrollers will be doing the processing of the data being transmitted and received. One sends information to the RF Module transmitter and the other PIC understands and executes the information sent to it by the RF Module receiver.

ii. RF 434MHz transmitter module

This 5 pin module is small enough to fit into this project and add wireless communication.

iii. RF 434MHz receiver module

The RF interface receiver module is larger for demodulation and amplification circuitry. It also has a simple array of power, ground and data pins to connect up with the PIC's USART.

iv. Two LM7805 +5v Regulators

Two of these +5V regulators are used to control the battery input down to +5 volts. This is the power needed to run the PIC microcontrollers and can also be used for the RF transmitter and receiver modules. The LM7805 takes battery input and regulates it down to +5V.

#### 4.2.2 Testing

To confirm that the proper information is being received, two testing circuits are built on the breadboards as shown in Figure 21 and 22 by using two buttons for input which will be present on the transmitter part and two LEDs for output on the receiver part. Suppose that one button is pressed, a specific command will light up one LED; when the other button is pressed, the other LED will be turned on. To produce this action, the two PIC18F452s are being programmed with two firmware files (see Appendix C) by using PIC Kit 2 software.

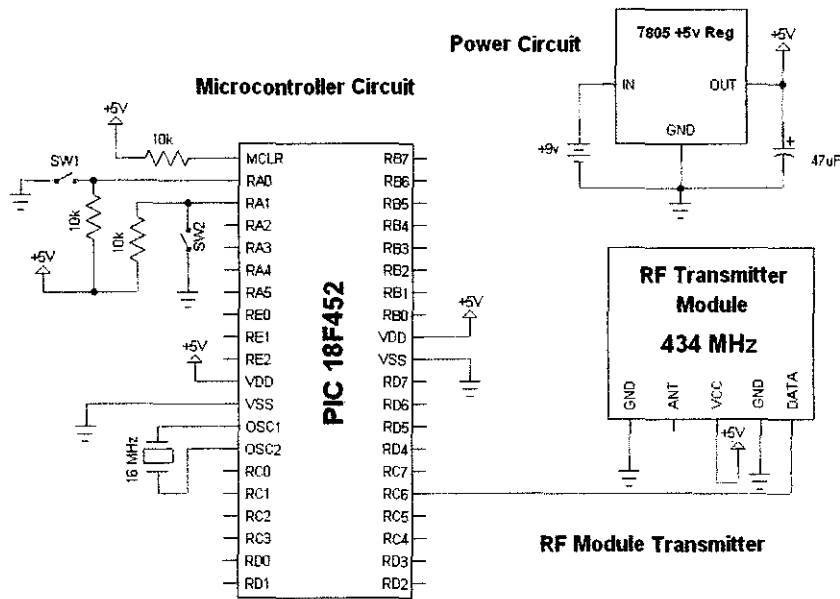

Figure 21: Schematic of Transmitter part

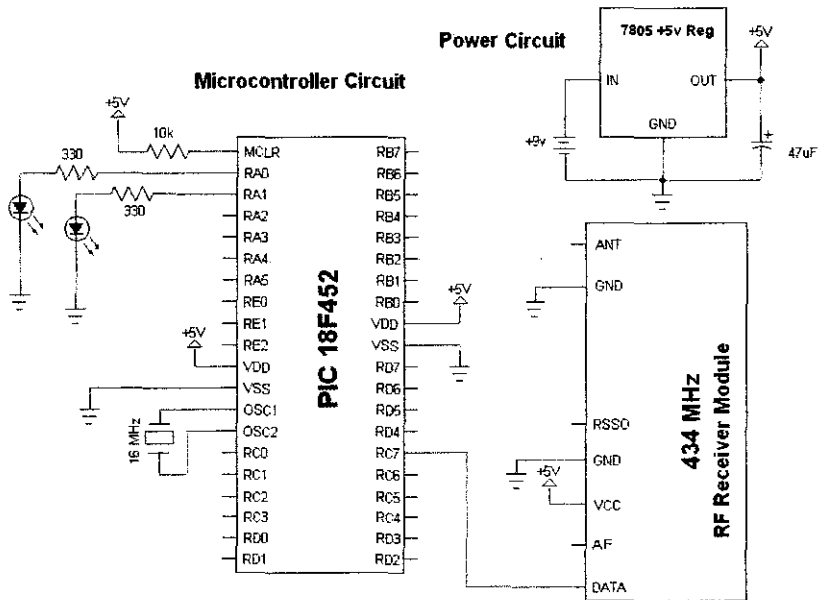

Figure 22: Schematic of Receiver part

The circuit was then tested using an analog oscilloscope. The output signal produced by the RF transmitter is shown in Figure 23.



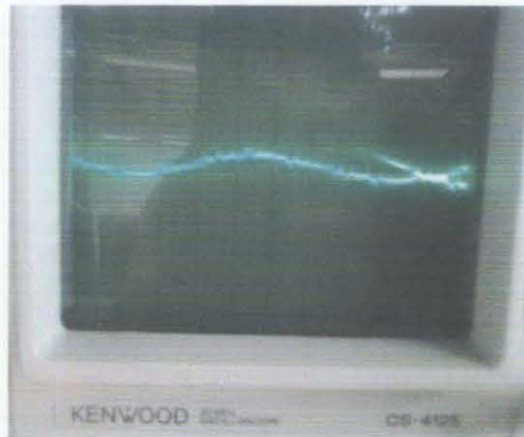

Figure 23: Output signal of RF transmitter

The output signal produced by the RF transmitter is in sinusoidal waveform. The output is not accurate as it should be in triangular waveform since the transmission is in digital form. On the other hand, the output signal produced by the RF receiver is a 5V peak-to-peak triangular waveform as shown in Figure 24. The output is not accurate too since the signal that was transmitted by the receiver should be same with the signal received at the receiver. The configuration on wireless transmission circuit must be checked properly to avoid unwanted signal.

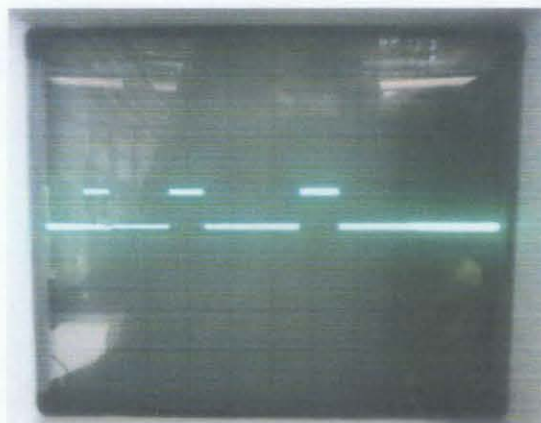

Figure 24: Output signal of RF receiver

Then, another testing was performed by applying frequency as the input to the PIC18F452 at the transmitter part. The frequency applied was 5Hz. The output signal for both RF transmitter and receiver were measured using digital storage oscilloscope as shown in Figure 25.

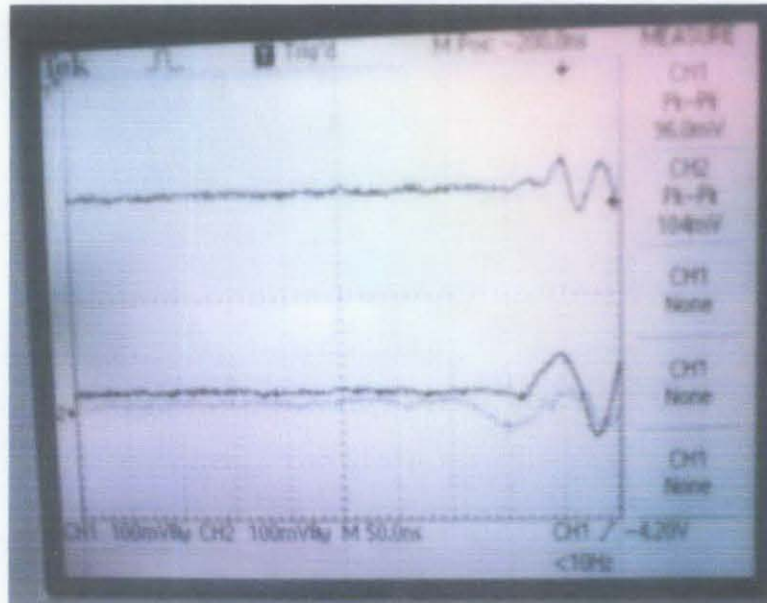

Figure 25: Output signal of RF receiver and transmitter

The upper signal shows the output for the RF transmitter and the lower signal shows the output for the RF receiver. The measurement shows that both output signals are quite similar despite the differences on the peak-to-peak voltages. For the transmitter output, the peak-to-peak voltage is 96.0mV and the receiver output produces a bigger peak-to-peak voltage which is 104mV.

The next step that should be furthered is to make sure that the EMG signal can be transmitted wirelessly using the RF transmitter and receiver. The main concern is to find a suitable sampling frequency so that the signal can be recorded in the plotter software.

## **CHAPTER 5: CONCLUSION**

As mentioned earlier in the objective, the main purpose is to design and build a wireless electromyography recorder which allows for wireless collection and recording of EMG signals. In the mean time, the objective of this project has not been fully achieved yet. The biggest challenge in this project is to make sure that the signal is sent successfully through the wireless medium and record it. In order to get an accurate signal, extra attention should be put on the wireless transmission.

As conclusion, this project is not complete 100% yet. If this project can be implemented successfully, it will bring many benefits to the user, especially the one with muscle diseases, and it can be applied in other advanced applications such as moving a wheelchair.

## REFERENCES

- [1] "Emil du Bois-Reymond", 2011,  
<http://neuroportraits.eu/portrait/emil-du-bois-reymond>
- [2] "ZeroWire",  
<http://www.noraxon.com/products/zerowire.php>
- [3] Jonghwa Kim, Stephan Mastnik, Elisabeth André, EMG-based Hand Gesture Recognition for Realtime Biosignal Interfacing, Lehrstuhl für Multimedia Konzepte und ihre Anwendungen, Germany, 30-39, 2008.
- [4] Thomas H.Cooke, Wireless Transmitter for Needle Electrodes as Used in Electromyography, United States Patent Number: 5579781, 1996.
- [5] Jamie Bell, Andrew Tutt, Brian Schulte, Show Wang, The Wireless ECG Device, BME 227L- Design in Biotechnology Final Report, 2009.
- [6] "Electromyography",  
<http://en.wikipedia.org/wiki/Electromyography>
- [7] Basics of Surface Electromyography: Applied to Psychophysiology, 2008, Thought Technology Ltd, 2008.
- [8] "Important Factors in Surface EMG Measurement",  
[http://edge.rit.edu/content/P08027/public/IRB/Papers/intro\\_EMG.pdf](http://edge.rit.edu/content/P08027/public/IRB/Papers/intro_EMG.pdf)
- [9] T. S. Poo, K. Sundaraj, 2010, Design and Development of a Low Cost EMG Signal Acquisition System Using Surface EMG Electrode, School of Mechatronic Engineering, Universiti Malaysia Perlis (UniMAP), 2010.
- [10] Gerdle B, Karlsson S, Day S, Djupsjöbacka M, 1999, Acquisition, Processing and Analysis of the Surface Electromyogram. Modern Techniques in Neuroscience, Chapter 26: 705-755. Eds: Windhorst U and Johansson H. Springer Verlag, Berlin, 1999.
- [11] "Electromyography Fundamentals",  
<http://myweb.wvu.edu/~chalmers/EMGfundamentals.pdf>
- [12] "Signal Filtering",  
<http://www.adinstruments.com/solutions/attachments/pr-signalfilters-05a.pdf>
- [13] Gianluca De Luca, Fundamental Concepts in EMG Signal Acquisition, Rev.2.1, March 2003, Delsys Inc., 2001.

- [14] C.N. Chien, H.W. Hsu, J.K. Jang, C.L. Rau, F.S. Jaw, Microcontroller- based wireless recorder for biomedical signals, National Taiwan University, Taipei, Taiwan, 2005.
- [15] “Survey Paper: Medical Application of Medical Network”, [http://www1.cse.wustl.edu/~jain/cse574-06/ftp/medical\\_wireless.pdf](http://www1.cse.wustl.edu/~jain/cse574-06/ftp/medical_wireless.pdf),2006.
- [16] “Wireless + Arduino + of [Tutorial]”, 2010, <http://www.creativeapplications.net/sound/wireless-arduino-of-tutorial/>
- [17] “Kendall Medi-Trace 200 Foam Electrode”, 2011, <http://www.cardiologyshop.com/kenmed200foa.html>
- [18] Dr. Roberto Merletti, Standards for Reporting EMG Data, International Society of Electrophysiology and Kinesiology (ISE), 1999.
- [19] “Active Full Wave Rectifier”, [http://nptel.iitm.ac.in/courses/Webcourse-contents/IIT-ROORKEE/Analog\\_circuits/lecturers/lecture\\_17/lecture17\\_page1.htm](http://nptel.iitm.ac.in/courses/Webcourse-contents/IIT-ROORKEE/Analog_circuits/lecturers/lecture_17/lecture17_page1.htm)
- [20] “MATLAB R2009b”, <https://help.ubuntu.com/community/MATLAB/R2009b>

# PIC18FXX2

TABLE 1-3: PIC18F4X2 PINOUT I/O DESCRIPTIONS

Pin Name	Pin Number			Pin Type	Buffer Type	Description
	DIP	PLCC	TQFP			
MCLR/VPP <u>MCLR</u> VPP	1	2	18	I  I	ST  ST	Master Clear (input) or high voltage ICSP programming enable pin. Master Clear (Reset) input. This pin is an active low RESET to the device. High voltage ICSP programming enable pin.
NC	—			—	—	These pins should be left unconnected.
OSC1/CLKI OSC1  CLKI	13	14	30	I  I	ST  CMOS	Oscillator crystal or external clock input. Oscillator crystal input or external clock source input. ST buffer when configured in RC mode, CMOS otherwise. External clock source input. Always associated with pin function OSC1. (See related OSC1/CLKI, OSC2/CLKO pins.)
OSC2/CLKO/RA6 OSC2  CLKO  RA6	14	15	31	O  O  I/O	—  —  TTL	Oscillator crystal or clock output. Oscillator crystal output. Connects to crystal or resonator in Crystal Oscillator mode. In RC mode, OSC2 pin outputs CLKO, which has 1/4 the frequency of OSC1 and denotes the instruction cycle rate. General Purpose I/O pin.
RA0/AN0 RA0 AN0 RA1/AN1 RA1 AN1 RA2/AN2/VREF- RA2 AN2 VREF- RA3/AN3/VREF+ RA3 AN3 VREF+ RA4/T0CKI RA4 T0CKI RA5/AN4/SS/LVDIN RA5 AN4 SS LVDIN RA6	2  3  4  5  6  7	3  4  5  6  8	19  20  21  22  23  24	I/O I I/O I I/O I I/O I I/O I I/O I I/O I I/O I I/O I I/O I	TTL Analog TTL Analog TTL Analog Analog TTL Analog Analog ST/OD ST TTL Analog ST Analog	PORTA is a bi-directional I/O port.  Digital I/O. Analog input 0. Digital I/O. Analog input 1. Digital I/O. Analog input 2. A/D Reference Voltage (Low) input. Digital I/O. Analog input 3. A/D Reference Voltage (High) input. Digital I/O. Open drain when configured as output. Timer0 external clock input. Digital I/O. Analog input 4. SPI Slave Select input. Low Voltage Detect Input. (See the OSC2/CLKO/RA6 pin.)

Legend: TTL = TTL compatible input

ST = Schmitt Trigger input with CMOS levels

O = Output

OD = Open Drain (no P diode to V<sub>DD</sub>)

CMOS = CMOS compatible input or output

I = Input

P = Power

# PIC18FXX2

TABLE 1-3: PIC18F4X2 PINOUT I/O DESCRIPTIONS (CONTINUED)

Pin Name	Pin Number			Pin Type	Buffer Type	Description
	DIP	PLCC	TQFP			
RB0/INT0 RB0 INT0	33	36	8	I/O I	TTL ST	PORTB is a bi-directional I/O port. PORTB can be software programmed for internal weak pull-ups on all inputs.  Digital I/O. External Interrupt 0.
RB1/INT1 RB1 INT1	34	37	9	I/O I	TTL ST	External Interrupt 1.
RB2/INT2 RB2 INT2	35	38	10	I/O I	TTL ST	Digital I/O. External Interrupt 2.
RB3/CCP2 RB3 CCP2	36	39	11	I/O I/O	TTL ST	Digital I/O. Capture2 input, Compare2 output, PWM2 output.
RB4	37	41	14	I/O	TTL	Digital I/O. Interrupt-on-change pin.
RB5/PGM RB5 PGM	38	42	15	I/O I/O	TTL ST	Digital I/O. Interrupt-on-change pin. Low Voltage ICSP programming enable pin.
RB6/PGC RB6 PGC	39	43	16	I/O I/O	TTL ST	Digital I/O. Interrupt-on-change pin. In-Circuit Debugger and ICSP programming clock pin.
RB7/PGD RB7 PGD	40	44	17	I/O I/O	TTL ST	Digital I/O. Interrupt-on-change pin. In-Circuit Debugger and ICSP programming data pin.

Legend: TTL = TTL compatible input  
 ST = Schmitt Trigger input with CMOS levels  
 O = Output  
 OD = Open Drain (no P diode to VDD)

CMOS = CMOS compatible input or output  
 I = Input  
 P = Power

# PIC18FXX2

**TABLE 1-3: PIC18F4X2 PINOUT I/O DESCRIPTIONS (CONTINUED)**

Pin Name	Pin Number			Pin Type	Buffer Type	Description
	DIP	PLCC	TQFP			
RC0/T1OSO/T1CKI	15	16	32	I/O	ST	PORTC is a bi-directional I/O port.  Digital I/O. Timer1 oscillator output. Timer1/Timer3 external clock input.
RC0				O	—	
T1OSO				I	ST	
T1CKI						
RC1/T1OSI/CCP2	16	18	35	I/O	ST	Digital I/O. Timer1 oscillator input. Capture2 input, Compare2 output, PWM2 output.
RC1				I	CMOS	
T1OSI				I/O	ST	
CCP2						
RC2/CCP1	17	19	36	I/O	ST	Digital I/O. Capture1 input/Compare1 output/PWM1 output.
RC2				I/O	ST	
CCP1						
RC3/SCK/SCL	18	20	37	I/O	ST	Digital I/O. Synchronous serial clock input/output for SPI mode. Synchronous serial clock input/output for I <sup>2</sup> C mode.
RC3				I/O	ST	
SCK						
SCL				I/O	ST	
RC4/SDI/SDA	23	25	42	I/O	ST	Digital I/O. SPI Data In. I <sup>2</sup> C Data I/O.
RC4				I	ST	
SDI				I/O	ST	
SDA						
RC5/SDO	24	26	43	I/O	ST	Digital I/O. SPI Data Out.
RC5				O	—	
SDO						
RC6/TX/CK	25	27	44	I/O	ST	Digital I/O. USART Asynchronous Transmit. USART Synchronous Clock (see related RX/DT).
RC6				O	—	
TX				I/O	ST	
CK						
RC7/RX/DT	26	29	1	I/O	ST	Digital I/O. USART Asynchronous Receive. USART Synchronous Data (see related TX/CK).
RC7				I	ST	
RX				I/O	ST	
DT				I/O	ST	

Legend: TTL = TTL compatible input  
 ST = Schmitt Trigger input with CMOS levels  
 O = Output  
 OD = Open Drain (no P diode to V<sub>DD</sub>)

CMOS = CMOS compatible input or output  
 I = Input  
 P = Power



# PIC18FXX2

TABLE 1-3: PIC18F4X2 PINOUT I/O DESCRIPTIONS (CONTINUED)

Pin Name	Pin Number			Pin Type	Buffer Type	Description	
	DIP	PLCC	TQFP				
RD0/PSP0	19	21	38	I/O	ST TTL	PORTD is a bi-directional I/O port, or a Parallel Slave Port (PSP) for interfacing to a microprocessor port. These pins have TTL input buffers when PSP module is enabled.  Digital I/O. Parallel Slave Port Data.	
RD1/PSP1	20	22	39	I/O	ST TTL		
RD2/PSP2	21	23	40	I/O	ST TTL		
RD3/PSP3	22	24	41	I/O	ST TTL		
RD4/PSP4	27	30	2	I/O	ST TTL		
RD5/PSP5	28	31	3	I/O	ST TTL		
RD6/PSP6	29	32	4	I/O	ST TTL		
RD7/PSP7	30	33	5	I/O	ST TTL		
RE0/ $\overline{RD}$ /AN5 RE0 RD  AN5 RE1/ $\overline{WR}$ /AN6 RE1 WR  AN6 RE2/ $\overline{CS}$ /AN7 RE2 CS  AN7	8	9	25	I/O	ST TTL  Analog  ST TTL  Analog  ST TTL  Analog	PORTE is a bi-directional I/O port.  Digital I/O. Read control for parallel slave port (see also $\overline{WR}$ and $\overline{CS}$ pins). Analog input 5.  Digital I/O. Write control for parallel slave port (see $\overline{CS}$ and $\overline{RD}$ pins). Analog input 6.  Digital I/O. Chip Select control for parallel slave port (see related $\overline{RD}$ and $\overline{WR}$ ). Analog input 7.	
Vss	12, 31	13, 34	6, 29	P	—		Ground reference for logic and I/O pins.
VDD	11, 32	12, 35	7, 28	P	—		Positive supply for logic and I/O pins.

Legend: TTL = TTL compatible input

ST = Schmitt Trigger input with CMOS levels

I = Input

O = Output

OD = Open Drain (no P diode to VDD)

CMOS = CMOS compatible input or output

I = Input

P = Power



## FM TRANSMITTER & RECEIVER HYBRID MODULES.

## FM-RTFQ SERIES FM-RRFQ SERIES

- FM Radio Transmitter & Receivers
- Available As 315 or 433 or 868MHz
- Transmit Range Up To 250m
- Miniature Packages
- Data Rate upto 9.6Kbps
- No Adjustable Components
- Very Stable Operating Frequency
- Operates from -20 to +85°C

### Transmitter

- 3-12 Supply Voltage
- SIL or DIL Package

### Receiver

- PLL XTAL Design
- CMOS/TTL Output
- RSSI Output
- **Standby Mode (max 100nA)**
- 5V Supply Voltage

### Applications

- Wireless Security Systems
- Car Alarms
- Remote Gate Controls
- Remote Sensing
- Data Capture
- Sensor Reporting

### Description

These miniature RF modules provide a cost effective high performance FM Radio data link, at either 315, 433.92 or 868MHz. Manufactured using laser trimmed Thick Film ceramic Hybrid the modules exhibits extremely stable electronic characteristics over an Industrial Temperature range. The hybrid technology uses no adjustable components and ensures very reliable operation.

This transmitter and receiver pair enables the simple implementation of a data link at distances upto 75 metres in-building and 250 metres open ground.

These modules will suit one-to-one and multi-node wireless links in applications including car and building security, EPOS and inventory tracking, remote industrial process monitoring and computer networking. Because of their small size and low power requirements, both modules are ideal for use in portable, battery-powered applications such as hand-held terminals.



RTFQ1

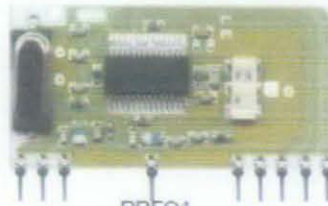

RRFQ1

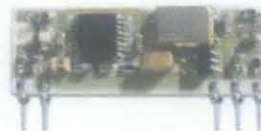

RTFQ2



RRFQ2



# FM TRANSMITTER & RECEIVER HYBRID MODULES.

# FM-RTFQ SERIES FM-RRFQ SERIES

### Transmitters

There are two versions of transmitter:

- RTFQ1: A Dual in Line Package operating at 3.3V. This provides the most rugged mechanical fixing to the host PCB. Power Down mode is also available.
- RTFQ2: A Single in Line Package incorporating a voltage regulator for 3-12V operation. (Compatible with many other RF transmitter modules available)

### Transmitter Block Diagram

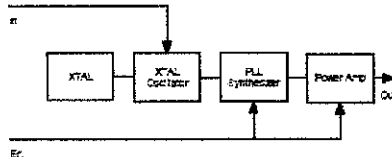

### Part Numbering

Part Number	Description
FM-RTFQ1-315	DIL FM Transmitter Module 315 MHz
FM-RTFQ1-433	DIL FM Transmitter Module 433.92 MHz
FM-RTFQ1-868	DIL FM Transmitter Module 868.35 MHz
FM-RTFQ2-433R	SIL FM Transmitter Module 433.92 MHz 3-12V I/P
FM-RTFQ2-868R	SIL FM Transmitter Module 868.35 MHz 3-12V I/P

### Receivers

There are two versions of receiver:

- RRFQ1: A Single in Line Package with sleep / Power down mode.
- RRFQ2: A Single in Line Package, pin compatible with many other receivers

### Receiver Block Diagram

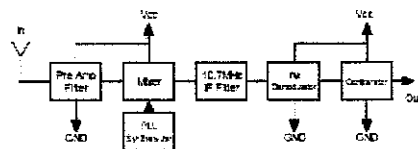

### Part Numbering

Part Number	Description
FM-RRFQ1-315	SIL FM Receiver Module 315 MHz
FM-RRFQ1-433	SIL FM Receiver Module 433.92 MHz
FM-RRFQ1-868	SIL FM Receiver Module 868.35 MHz
FM-RRFQ2-433	SIL FM Receiver Module 433.92 MHz
FM-RRFQ2-868	SIL FM Receiver Module 868.35 MHz



# FM TRANSMITTER & RECEIVER HYBRID MODULES.

# FM-RTFQ SERIES FM-RRFQ SERIES

## RTFQ1 Mechanical Dimensions

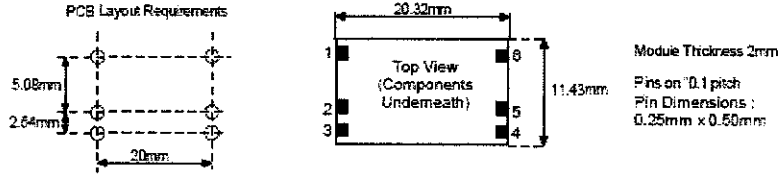

## RTFQ2 Mechanical Dimensions

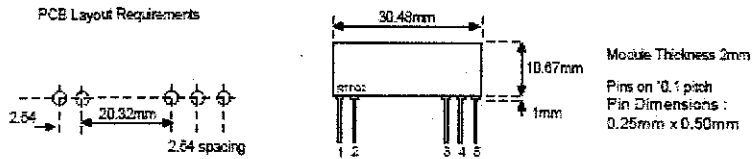

## Pin Description

RTFQ1	RTFQ2	Name	Description
1	N/A	En	Enable (active high)
2	5	IN	Data input
3	1	GND	Ground. Connect to RF earth return path
4	3	Vcc	Supply Voltage
5	4	GND	Ground. Connect to RF earth return path
6	2	EA	External Antenna

## Technical Specifications

Electrical Characteristics	MIN	TYPICAL	MAX	DIMENSION
Supply Voltage RTFQ1	2.1	3.3	4.00	V
Supply Voltage RTFQ2	2.5		12.00	V
Supply Current		7	8	mA
Standby Current (IN = EN = Low)			100	nA
Frequency		315.0 433.92 886.35		MHz
RF Output into 50Ω (Vcc=3.3V)		+5 / +5 / +1		dBm
Initial Frequency Accuracy	-35	0	+35	KHz
FM Deviation	25	30	35	KHz
Harmonic Spurious Emissions		-50		dBc
Input High Voltage RTFQ1	1.5		Vcc	V
Input High Voltage RTFQ2	1.5		5.5	V
Power up Time (En to full RF)			1	mS
Power up Time (Power on to full RF)			5	mS
Max Data Rate			9.6	KHz
Operating Temperature	-25		+80	°C



## FM TRANSMITTER & RECEIVER HYBRID MODULES.

## FM-RTFQ SERIES FM-RRFQ SERIES

### RRFQ1 Mechanical Details

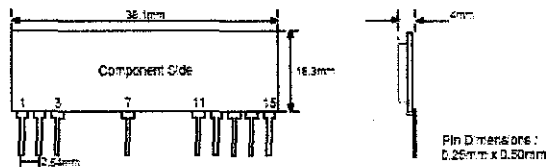

### RRFQ2 Mechanical Details

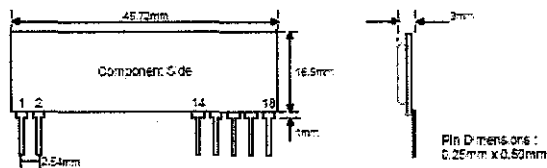

### Pin Description

RRFQ1	RRFQ2	Pin Description
1	16	+Vcc
2, 7, 11	2, 15	GND
3	1	Data In (Antenna)
12		NC
13	14	Received Signal Strength Output
N/A	17	AF Output
14	18	Data Out
15	N/A	Power Down 0V = Standby 5V = Operating

### RSSI Output\*

RF In (dBm)	RSSI (V)
-120	1.20
-110	1.32
-100	1.50
-90	1.78
-80	2.06
-70	2.35
-60	2.62
-50	2.72
-40	2.75

### RSSI Output

The RSSI provides a DC Voltage proportional to the peak value of the receive data signal. This output can be used as an indicator for the received signal strength to use in wake-up circuits etc.

An RC circuit is normally used to provide the timing for the RSSI signal. The modules have a 10nF capacitor internally connected to GND, therefore a pull down resistor (to GND) connected to the RSSI pin may be used to generate a simple RC network time constant for the RSSI signal output.

Please note that the maximum output current is typically 950µA, the discharge current is lower than 2µA



**FM TRANSMITTER & RECEIVER  
HYBRID MODULES.**

**FM-RTFQ SERIES  
FM-RRFQ SERIES**

**Technical Specifications**

Electrical Characteristics	Min	Typical	Max	Dimension	Notes
Supply Voltage (Vcc)	4.5	5	5.5	V	
Supply Current (Operating)		5.7	6.8	mA	
Supply Current (Standby)			100	nA	
Receiver Frequency		315.00 433.92 868.35		MHz	
R.F Sensitivity (100% AM) 315, 433MHz versions 868MHz versions		-103 -100		dBm	
3dB Bandwidth		+/-150		KHz	
Data Rate	300		9,600	Hz	
Turn on Time			5	mSecs	1
Turn on Time		8		mSecs	2
Level of Emitted Spectrum			-70	dBm	
Low Level Output Voltage			0.8	V	I = 200uA
High Level Output Voltage	Vcc-1			V	I = 200uA
RSSI Output		0.95		mA	
Operating Temperature Range	-25		+60	°C	

Notes

1. Time from PD pin going high to stable data. (RRFQ1 only)
2. Time from Power ON to stable data.



# FM TRANSMITTER & RECEIVER HYBRID MODULES.

# FM-RTFQ SERIES FM-RRFQ SERIES

### Typical Application

The following circuits show a remote control system with 'self learning feature' for more information please see Datasheet DS600

Transmitter Circuit

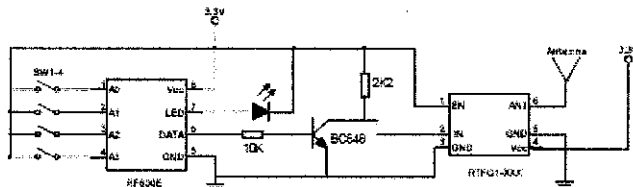

Receiver Circuit

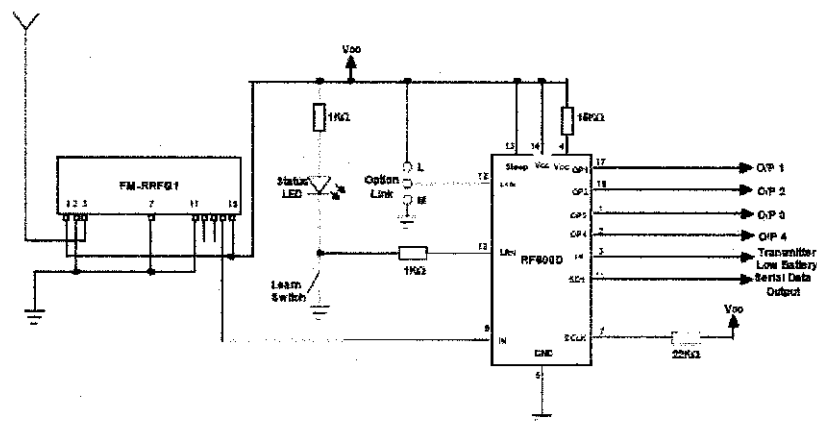

### Prototyping Hints:

It is essential when building any Low Power Radio System that you have a 'clean' DC power source. Typically the ripple voltage should be less than 10mV Peak to Peak. Normally a 470uF decoupling capacitor is sufficient de-coupling for an AC derived DC power source.

Never place a Transmitter or Receiver directly into Vero-Board or any similar prototyping board. This will severely restrict the range. Rather, use small lengths of wire from the prototyping board to the pins of the Transmitter or Receiver.

A useful antenna, for testing purposes, for both the Transmitter and Receiver on 433MHz is to use a piece of wire 17.3cm long (23.8cm at 315MHz) soldered directly to the antenna pin.

For more information or general enquiries, please contact:

**RF Solutions Ltd.,**

*Unit 21, Cliffe Industrial Estate,*

*South Street, Lewes, E Sussex, BN8 6JL, England*

**Tel +44 (0)1273 898 000 Fax +44 (0)1273 480 661**

**Email [sales@rfsolutions.co.uk](mailto:sales@rfsolutions.co.uk)**

**<http://www.rfsolutions.co.uk>**

*RF Solutions is a member of the Low Power Radio Association*

**All Trademarks acknowledged and remain the property of the respected owners**

Information contained in this document is believed to be accurate, however no representation or warranty is given and R.F. Solutions Ltd. assumes no liability with respect to the accuracy of such information. Use of R.F. Solutions as critical components in life support systems is not authorized except with express written approval from R.F. Solutions Ltd.

## Appendix C: RF Transmitter and Receiver Firmware Files

### RF Transmitter Firmware

```
-----« Begin Code »-----
//*****Button/Command Output Control*****
//*****
//If No Button Pressed, Send Command L0
if(PORTDbits.RD0 == 1 &&
PORTDbits.RD1 == 1){
    //Turn LED ON
    putcUSART( '0' ); //write value of PORTD
    Delay10KTCYx(10);
    putcUSART( 'L' ); //write value of PORTD
    Delay10KTCYx(10);
}
//If Button #1 Is Pressed, Send Command L1
else if(PORTDbits.RD0 == 0 &&
PORTDbits.RD1 == 1){
    //Turn LED OFF
    putcUSART( '1' ); //write value of PORTD
    Delay10KTCYx(10);
    putcUSART( 'L' ); //write value of PORTD
    Delay10KTCYx(10);
}
//If Button #2 Is Pressed, Send Command L2
else if(PORTDbits.RD0 == 1 &&
PORTDbits.RD1 == 0){
    //Turn LED OFF
    putcUSART( '2' ); //write value of PORTD
    Delay10KTCYx(10);
    putcUSART( 'L' ); //write value of PORTD
    Delay10KTCYx(10);
}
//*****
-----« End Code »-----
```



## RF Receiver Firmware

-----« Begin Code »-----

```
//***** Button/LED Control *****
if(data_array[1] == 'L' &&
   data_array[2] == '0')
  PORTA= 0x00;
//**** Button 1 Pressed - LED #1 On ****
else if(data_array[1] == 'L' &&
   data_array[2] == '1')
  PORTA= 0x01;
//**** Button 2 Pressed - LED #2 On ****
else if(data_array[1] == 'L' &&
   data_array[2] == '2')
  PORTA= 0x02;
//*****
...
....
...
//Interrupt Evaluation Routine
if(PIR1bits.RCIF){
  buf = ReadUSART();
  data_array[7] = data_array[6];
  data_array[6] = data_array[5];
  data_array[5] = data_array[4];
  data_array[4] = data_array[3];
  data_array[3] = data_array[2];
  data_array[2] = data_array[1];
  data_array[1] = data_array[0];
  data_array[0] = buf;
  PIR1bits.RCIF = 0; //Clear RCIF Flag
}
```

-----« End Code »-----