

# ONLINE WOMEN SELF HEALTH CHECK SYSTEM

by

Maslydhia Bt. Maslan

Dissertation submitted in partial fulfillment of  
the requirement for the  
Bachelor of Technology (Hons)  
(Business Information System)

JANUARY 2006

Universiti Teknologi PETRONAS  
Bandar Sri Iskandar  
31750 Tronoh  
Perak Darul Ridzuan

t  
R858

. m394

2006

1) Medicine -- Information Technology  
2) IT / IS -- Thesis

**CERTIFICATION OF APPROVAL**

**The Implementation of Online Women Self Health Check System**

by

Maslydhia Maslan

A project dissertation submitted to the

Information System Programme

University Technology PETRONAS

In partial fulfillment of the requirement for the

**BACHELOR in BUSINESS INFORMATION SYSTEM (BIS)**

Minor in Corporate Management

Approved by,

---

(Ms. Emy Elyanee Mustapha)

UNIVERSITY TECHNOLOGY PETRONAS

TRONOH, PERAK

January 2006

## **CERTIFICATION OF ORIGINALTY**

This is to certify that I am responsible for the work submitted in this project, that the original work is my own except as specified in the references and acknowledgements, and that the original work contained herein have not been undertaken or done by unspecified sources of persons.

---

(Maslydhia Maslan)

## ACKNOWLEDGEMENT

First of all, thank to God for His Love, guidance and strength He has given me through out my final semester here in University Technology Petronas in finishing my Final Year Project.

There are so many people that always behind me helping me in ensuring the success of my project. There are my pillar of strength and also my inspiration. Without them this project will not be completed and succeed which is exceeded my own expectation.

I would like to thank my supervisor, Ms. Emy Elyanee Mustapha, for the valuable advice and support she has given me in implementing my final year project also in the writing of this report. All of her supportive comments, suggestion and expert guidance really teach me a lot in handling the entire tasks well this semester.

My huge and humble gratitude to all of my friends for their encouragement and guidance that they have gave me for the success of the project. Knowledge sharing really contributes a big amount in the success of the project.

Last but not least, the FYP Coordinator, in giving us the final semester student chances in increasing our marks by having additional tasks that really help us a lot. Thanks also to for the lovely cooperation that have been given by all hospitals and clinics that I have been gone for the project. THANK YOU!

## ABSTRACT

The research was done on two main cancers that having high percentage among women which are breast cancer and cervical cancer. The aim of the study is to investigate the problem that faced by women and overcome it by developing a system. The motivation in developing the system is to decrease the percentage of the leading cause of death among women. Research is done in the area of symptoms and risk factors of each cancer.

The system is focus specifically for women and the main findings of the research is related to female patient behavior and also factors that contributing to high percentage of breast cancer and cervical cancer each year. Research indicate that more than 500 new cases of breast cancer in Malaysia each year and it than followed by cervical cancer which indicate 12% of leading cause of death among women [The Star, 2005]. The dissertation, serves to provide women with information and steps in communicating the problem or curiosity rather than wait till it is at the end stage.

In order to overcome the problem Online Women Self Health Check System is developed. It is to ensure facts is transfer to more user friendly form that requires less reading but more action. This is because by using this system, users have to interact with the system whereby they have to follow the instruction given and give response to the result obtain base on the option given. As the result of the process, user will gain the risk level of the cancer and also list of hospital that located near to the user's location. This element is included in the system in encouraging user to go and have further consultation with specialist and gynecologist.

Methodology that applied in the system is incremental delivery. This is due to the content of the system which is related to symptoms and risk factors. Both of the elements have the potential to change overtime and thus, by using incremental delivery it allow changes and enhancement overtime.

By having the system, it helps in encouraging women in doing self examination and makes it as habit for healthier life style. Self examination is important as the start in decreasing the percentage because by having examination than only these cancers can be detected and cured.

## TABLE OF CONTENTS

<b>CERTIFICATION OF APPROVAL</b>	II
<b>CERTIFICATION OF ORIGINALITY</b>	III
<b>ACKNOWLEDGEMENT</b>	IV
<b>ABSTRACT</b>	V
<b>CHAPTER 1: INTRODUCTION</b>	1
1.1 Background of Study	1
1.2 Problem Statement	2
1.3 Objectives.	4
1.4 Scope of Study	5
<b>CHAPTER 2: LITERATURE REVIEW/THEORY</b>	6
2.1 Online System.	6
2.2 User's perspective	8
2.3 Health System	10
2.4 Decision Analysis	11
<b>CHAPTER 3: METHODOLOGY</b>	13
3.1 Procedure Identification	13
3.1.1 Project Management and Planning	13
3.1.2 Software Process	16
3.1.2.1 Requirement and Analysis Phase.	18
3.1.2.2 Interface Design Phase	19
3.1.2.3 Development of Coding Phase	20
3.1.2.4 Testing Phase.	22
3.2 Apparatus.	25
3.2.1 Software	25
3.2.2 Hardware.	26
3.2.3 Process Flow	26

<b>CHAPTER 4:</b>	<b>RESULT AND DISCUSSION</b>	27
4.1	Results	27
4.1.1	Interview	27
4.1.2	Questionnaires.	29
4.1.3	Heuristic Evaluation Sheets	32
4.2	Discussion	33
4.2.1	Online Women Self Health Check System	33
4.3	Recommendation	35
<b>CHAPTER 5:</b>	<b>CONCLUSION.</b>	36
<b>REFERENCES</b>		40



## LIST OF FIGURES

Figure 1: Overall Process Groups in a Phase.....	15
Figure 2: Incremental Model Flow Diagram .....	17
Figure 3: Female Favorite Color by Joe Hallock.....	19
Figure 4: Flow chart of Breast Cancer Question .....	21
Figure 5: Process of Manipulating Input for Output.....	26
Figure 6: Results for Questionnaire .....	30
Figure 7: Female Favorite Color – Author’s survey .....	31
Figure 8: Heuristic Evaluation Result.....	32

## **APPENDICES**

**APPENDIX A: Project Gantt Chart**

**APPENDIX B: Questionnaire for Target User**

**APPENDIX C: Use Case Diagram**

**APPENDIX D: Data Flow Diagram**

**APPENDIX E: Flow Chart for Breast Cancer**

**APPENDIX F: Flow Chart for Cervical Cancer**

**APPENDIX G: Project System Architecture**

**APPENDIX H: List of Question based on symptoms**

**APPENDIX I: Heuristic Evaluation Sheet**

**APPENDIX J: ONLINE WOMEN SELF HEALTH CHECK SYSTEM**

# CHAPTER 1

## INTRODUCTION

### 1.1 Background of Study

Online Women Self Health Check System is an interactive web based application that focuses on two cancers and three diseases that have high percentage among women in Malaysia. The cancers are breast cancer and cervical cancer while the other three are depression, migraine and menopause. The system enable user to interact their condition and history of health according to the questions asked in the system. All of the questions that provided in the system are all base on the research that had been done through medical books and also from a few interviews have been conducted among gynecologist. This is to ensure the validity of the questions relate to the cancer and disease that available in the system.

The system actually enhances the method that currently available for users whereby they have to set an appointment and wait for the result in having the diagnosis where it is very time consuming. Mainly the project serves to help user in being a place for them to actually expressing their condition instead of not doing anything. Further explanation on the system will be describe later in the dissertation

Percentage of death in breast cancer and cervical cancer is increasing every year and the main factor is because of late detection [The Star, 2005]. Thus, this system will help in decreasing the percentage by having a system that allow user to communicate their condition of health at anytime they want. Women actually do not feel comfortable in confiding things that they feel private and embarrassing and one of it is gynecology examination [Dr Alex, 2000], thus this system will act as a place for

them to determine the risks of having the cancers and proceed with further examination later.

## **1.2 Problem Statement**

Malaysia for the recent years is facing with increasing in the percentage of breast cancer and cervical cancer. There are more than 500 new cases of breast cancer in Malaysia each year than followed by cervical cancer which indicate 12% of leading cause of death among women [The Star, Sept 28 2005].

The root of this problem is actually because of lack of consciousness among women in Malaysia. They tend to think positively and therefore do not take any action in doing diagnosis or checkup. Government, Malaysia women's organization, private and public hospitals have played their role in reminding women about the importance of breast check and cervical check but still it is the mind set that still think that diagnosis is not importance and wait till its really at the end stage and as the result about 45% of patient are in the end stage [The Star, Sept 28 2005].

Female patient is different than male patient, thus doctors and nurses have their own courses in approaching them. Most female patient fear of gynecology examination and think her sexual and reproductive experiences and organ function are quite individual, thus feel uncomfortable confiding things that they consider private or embarrassing [Dr Alex, 2000]. This is answered the reason of the 45% of patient that already at the end stage, because of embarrass, women tend to keep their health condition to themselves and till they cannot hold it anymore than only they went to see the gynecologist and seek for diagnosis. Other reason is because most of female patients do not want to put themselves in a position where it's possible that they might receive bad news and thus they rather bury their heads in the sand.

Women in Malaysia have to change the mind set, this is because breast check and cervical check is not something that should be done inconsistently but it is something that should be done consistently where for breast cancer it should be done monthly and cervical cancer every 10 days after period [The Star, Dec 11 2005]. It is not only a matters on general health, nutrition and work commitment only to worry about but also on cancers that need to take importance by women.

As a result, the system serves as beacon of information and support to user where it becomes a medium for women in expressing their curiosity. It also ensures increasing number of women in doing self-examination and to encourage women in making self-diagnosis as a habit.

By creating the new mind set thus, it will decrease the percentage of late detection of cancer. This is because no restriction of time in doing diagnosis and also overcome the problem of embarrassment due to the self-examination. Therefore, there should not be any ignorance anymore among women for not making self-examination as a habit because when it becomes habit automatically the percentage of breast cancer and cervical cancer in Malaysia will decrease simultaneously.

### 1.3 Objectives

There are five objectives of developing the web-based system, which are all contributing to women.

- ✓ To investigate the two most high percentage cancers in Malaysia which are breast cancer and cervical cancer
- ✓ To ensure immediate checkup and result at any time convenience to user and thus the system is develop as web based system to ensure it can caters users problem at anytime convenience to users
- ✓ To develop a system that will help user in doing self-examination by interactively following steps provided in the system. Responses are referring to option gives for every question.
- ✓ To determine the level of risk for each cancer and disease in the system by calculating the risk factors
- ✓ To lead user to the nearest clinic and hospital that within user area

## 1.4 Scope of Study

Online Women Self-Health Check System is essentially for women, thus the target user is among women at age 20 and above. The focus is mainly on cancers that related to women with high percentage in Malaysia which are breast cancer and cervical cancer. Include also in the system also other three diseases, which are menopause, migraine and depression. The three diseases are included in the system because it is among the high percentage that arises among women.

The project did not include all of cancers that occur among women and men because of the time constraint and it is impossible for author to do research on all of the cancers, thus it had been narrowed down. It also to ensure the project can be done within time frame and having high value to user in the existence of the development. Besides that, it is also because of author knowledge that is lack in medical area, thus specific research need to be conducted to ensure all of the information gathered is precise for the system.

- ✓ Mainly for female patients because percentage of cancers that is high in Malaysia is both occur among women
- ✓ Only include cancers and diseases that can be done individually by having steps for user to follow (self-examination)
- ✓ Providing user with result which is level of risk and location of hospital and clinic that near to user's location

## CHAPTER 2

### LITERATURE REVIEW

#### 2.1 Online System

Online application or system becomes more preferable among people nowadays. This is due to the availability of internet whereby it is the main tools in gaining information and knowledge for example covers information and support to patients, caregivers and survivors of cancer [Joseph, 2005].

The functionality of internet is wide and it acts as the most useful application because of the information and knowledge it stored, thus changes need to be done for this decade whereby by the existence of internet more online system is needed in ensuring the application is been use to maximum. Furthermore the cost needed in getting all of the information available is little as compared to the information that the user will gain, thus it become one of the most preferable tools in gaining information [Lee, 2002]. Thus business or web developer should take the opportunity in satisfying user want and developing system that can be used by users for their conveniences.

*“Numerous statistic show the popularity of the internet among this population and numerous efforts continue to grow in the purposeful development and refinement of online services for these individuals, or groups continue to expand and refine their own self-organized”* [Neil Starkman, 2005]



Interactivity of an online system is important in ensuring the quality and effectiveness of the system. This is because user going to use the system and interact with the system especially for the context of women self health check whereby they have to do their own diagnosis and thus, it is the most important thing to be ensured by the author. This statement also shows that the development of an online service should undergo specific investigation and process.

Due to the points highlighted above, it was decided to develop a web-based system in ensuring a large number of users having the opportunity in using the system. This is to fulfill the demand for nowadays and to ensure the problem statement mentioned earlier can be defeat successfully.

## 2.2 User's perspective

Cancer is hard to determine because it is all depends on patient awareness however cancer is easy to prevent if healthy lifestyle is adopted [Rachna, Luisita 2003]. In the process of determining cancer, patient will go thru a process of uncertainty response, which shaped by appraisals, emotional reactions and also affective responses, which consist of six responses:

“

- *Uncertainty is viewed as danger or threat*
- *Uncertainty is judged as beneficial*
- *Uncertainty is judged as inconsequential*
- *Uncertainty represents element of both danger and opportunity*
- *Uncertainty is ignored. It is overlooked and patient act as if it is not there*
- *Uncertainty is not evaluated but ignorance is adapted” [Branchers, 2001]*

The second response that need to be highlight for, and to tackle this behavior something need to be done in allowing user to communicate the uncertainty in their preferred way. As suggested by Branchers, there are five steps that need to be done in dealing with uncertainty are:

“

- *Construction of solidity, this is due to the problem of uncertainty that related to risk 'lack of rock in the dashing breakness'*
- *To acknowledge the uncertainty by constructing conditional statement, probability, questions, precaution and on top of all this need the credibility by stating the recommendation of therapy.*
- *To do delegation where by, by communicating uncertainty it allows others to consider uncertainty and to take a responsible decision while knowing the odds.*
- *By experiencing it as anchor*
- *By having the agreement on process and procedures. ” [Branchers, 2001]*

The steps suggested will be followed and applied in the system to ensure patient uncertainty is resolved. Recommendations of hospital for further checkup will be stated in helping patient making decision and dealing with their result accordingly.

## 2.3 Health System

Critical decisional process of environmental and health problems are based on five criteria which are having scientific study of the system, having relevant experimental data, medical diagnosis of critical case, environmental impacts and evaluation of the compliance [Koselleck, 1985].

*“It is possible that chemical pollution could eventually have an effect on human fertility. Studies in Europe and America show that most human fertility problems are on sperms counts, testicular, breast cancer and endometriosis”*  
[Mesman, 2002]

This statement proves that environmental impacts really bring effects to patients thus in doing the question banks this kind of questions should be think off. Their way of life, activities, eating behavior and environmental surrounding should be included in question banks to get more precise conditions of the patient.

*“With database functions and dynamic Web page technology, online health information systems can collect information from users and adapt content to them immediately, in real time and at any time (contingent and synchronous). Interfaces can be programmed to permit self-navigation (user involvement) among databases and multimedia programs using seamless hypertext links, without resorting to complicated, expensive expert systems”*  
[Joseph, 2005].

Management of databases involve in the system is very important in ensuring only selective data is displayed and stored in the system.

## 2.4 Decision Analysis

In determining the solution or result to a problem, decision analysis need to be done to ensure the result gain is accurate and follow the correct rules [Efrain, Jay & Ting 2005]. For the aspect of this system, the design flow of the questions that are going to be asked need to be taken as serious matter. Detail analysis need to be done to ensure the end result to user or patient is accurate and precise.

*“Decision tree is a graph of decisions and their possible consequences, used to create a plan to reach a goal. Decision trees are constructed in order to help with making decisions and a special form of tree structure. Decision tree is a predictive model that is, a mapping of observations about an item to conclusions about the item's target value. Each inner node corresponds to variable an arc to a child represents a possible value of that variable. A leaf represents the predicted value of target variable given the values of the variables represented by the path from the root” [Bruno, 1999].*

Decision tree learning is also a common method used in data mining. Here, a decision tree describes a tree structure wherein leaves represent classifications and branches represent conjunctions of features that lead to those classifications [T. Menzies, 2003]. A decision tree can be learned by splitting the source set into subsets based on an attribute value test [Rod, 1998]. This process is repeated on each derived subset in a recursive manner. The recursion is completed when splitting is either non-feasible, or a singular classification can be applied to each element of the derived subset. A random forest classifier uses a number of decision trees, in order to improve the classification rate [T. Menzies,2003].

Decision tree is possible to validate a model using statistical tests. That makes it possible to account for the reliability of the model. It also performs well with large data in a short time. Large amounts of data can be analysed using personal computers in a time short enough to enable stakeholders to take decisions based on its analysis [Hyprion.com, 2005]. This reflects to the objective of Online Women Self-Health Check System where by to give immediate response to patient curiosity and to let the patient take their own decision.

There are two steps in making productive use of decision trees which are building a decision tree model, and using the decision tree to draw inferences and make predictions [Yuk, Premme & Raymond 2005]. The first step in building a decision trees is to collect a set of data values which as in this matter the symptoms of the diseases or cancers. This data is called the "learning" or "training" dataset because it is used to learn how the value of a target variable is related to the values of predictor variables. This dataset must have instances for which the developer knows the actual value of the target variable and the associated predictor variables. Only then complex analysis will be done and builds a decision tree that models the data.

# CHAPTER 3

## METHODOLOGY

### 3.1 Procedure Identification

In order to have the end product of the project, one method of software process had been chosen and followed. Planning also play a vital role in ensuring the project meets all of the objectives within the time frame.

#### 3.1.1 Project Management and Planning

There are many groups that involved with the development of the project and thru the processes that occurs different group of people need to be approach in gaining and gathering the data. Below are the processes involved:

✓ **Initiating Process**

This process refers to the official acceptance of the proposed title after the submission of the preliminary report. Then interim and progress report have been submitted to show the research and progress of the project. Related groups involve are author, lecturer and librarian.

✓ **Planning Process**

Gantt chart is the first task that have been accomplish for this process in identifying and estimating the days needed for each task. This is to ensure the task is adherence to the plan. Identification of task to be completed thru the semester such as designing set of questionnaires for target users, performing interviews and developing a prototype for first draft of the project.

✓ **Executing Process**

This is the actual act of disseminating information, acquiring and using actual resources, including submitting the actual project deliverables. The executing process has been completed upon completion of the system.

✓ **Controlling Process**

This is the monitoring and measurement of the progress against the original plans and ensuring that any changes are accounted for. The Gantt chart served as a guideline and measures the days of the project from completion and whether the project was on track.

✓ **Closing Process**

This includes the submission of the final draft and the actual delivery and presentation of the Final Year Project.



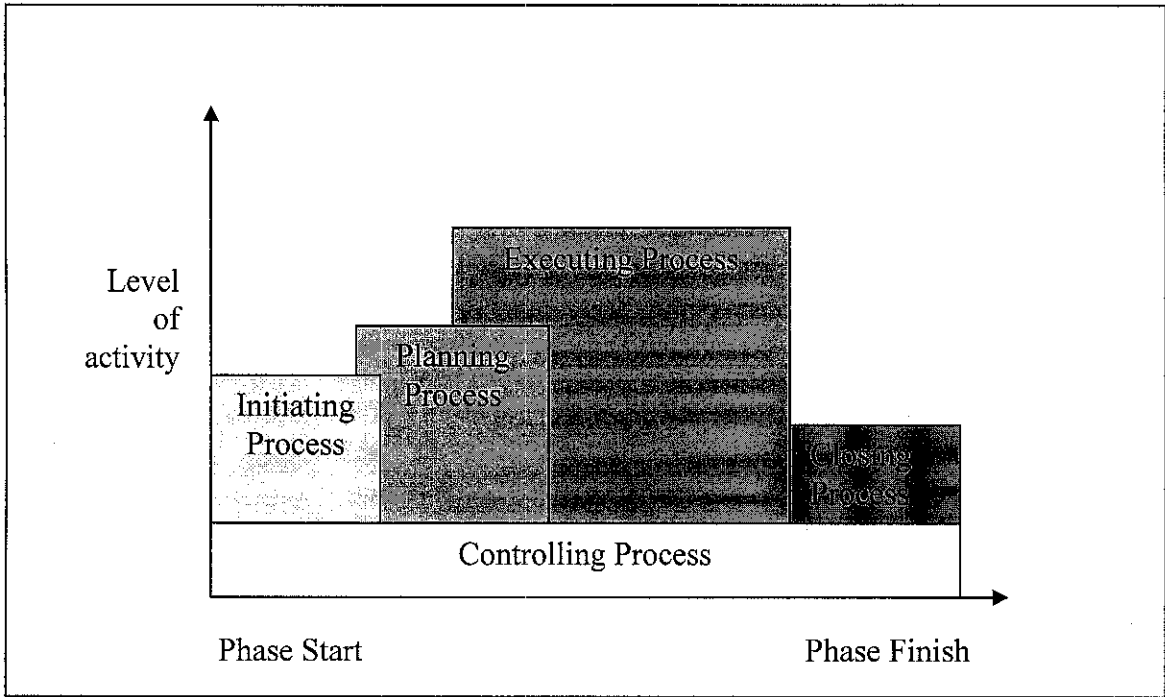
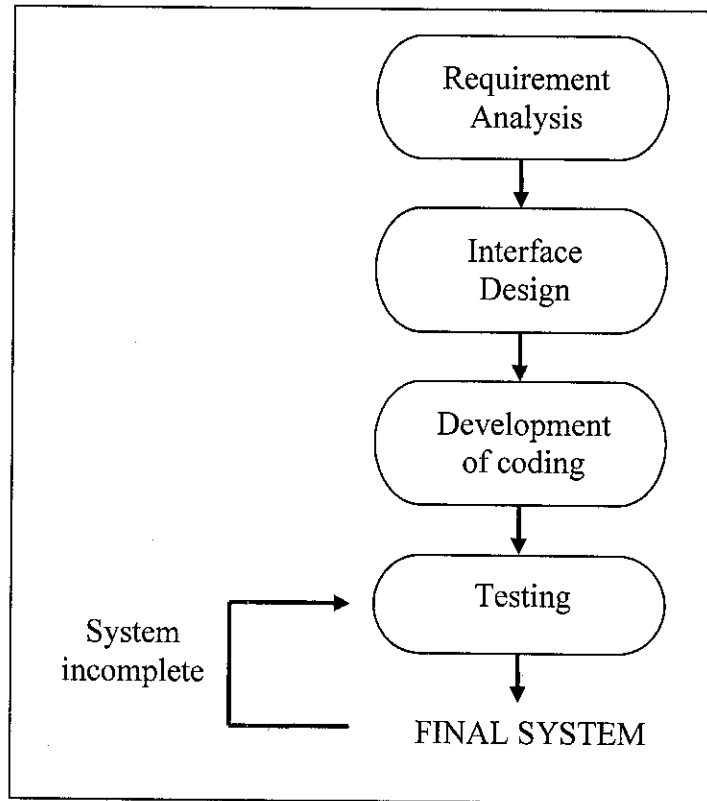

**Figure 1: Overall Process Groups in a Phase**

### **3.1.2 Software process**

Software process that has been chosen for Online Women Self-Health Check System is incremental delivery. This is because this process is the most appropriate process that can be applied in this system. Incremental delivery allows further requirements analysis for later increments thus it is suitable for the system where by the updating of latest information is rapidly occurred due to latest findings and changes of the content [Watts, 2005]. This then suited the system where changes symptoms of each cancers and diseases might occurred and thus, updating on the content need to be done.

Based on incremental model, four phases will involve in development of Online Women Self-Health Check System which are requirement analysis, interface design, development of coding, and finally testing. All these steps will be repeated in each build until retirement of the process where the product is complete. The flow of the model to be used during the development of Online Women Self-Health Check System is shown below:



**Figure 2: Incremental Model Flow Diagram**

### **3.1.2.1 Requirement and Analysis Phase**

In order to do analysis, problems, opportunities and objectives need to be identified first and this related to information that had been gathered earlier from medicals and health books. This is to ensure only scientific research in ensuring the accurateness of the information is gained. Besides that other ways had been determined and done like interviewing gynecologist, doctors, pharmacist and also medical students. Apart from the professional, research had also been done via the Internet by surfing the health websites and links that are available.

In interviewing the professional, a set of questions or list of questions had been prepared first. This is to ensure that only important questions are asked during the interview and only related information is asked and gained. Then author analyze the information gained by having short-listed of the symptoms for each cancer. Author have been interviewing specialist from hospital and clinic and total number of gynecologist that had been interviewed are 10, four from Ipoh Specialist Centre, three from Chinese Maternity Hospital, two from Pantai Medical Centre and one from Klinik Wanita Sidhu.

After analysis had been conducted and come out with set of questions for each cancers and diseases, then again author have to make an appointment with the gynecologist to show to them the short listed question and seek for their clarification and legitimacy of the questions. All of the comments and opinion from them are useful in implementing the system.

### 3.1.2.2 Interface Design Phase

The interface has been designed similarly for each cancer and disease to ensure homogeneous through the system. Human Computer Interaction (HCI) has been applied in determining all of the factors that is going to be included in the system and thus will ensure the user friendliness of the system [Beaumont, Stephen & James, 2002].

One of the challenges in the field of web design is choosing the right colors. Right colors can capture and seize the character of the business the design is representing [Maricon, 2005]. Further, it can also leave imprints to persuade viewers to patronize the system, thus author has make a research on color that highly preferred by women and the result that gained is red where it indicate 35% [Joe, 2005]. Beside that, to prove and to ensure the results among author target user, other research have been done whereby set of questionnaires had been distributed to 100 female students in University Technology Petronas and also other females outside. Refer to Appendix B.

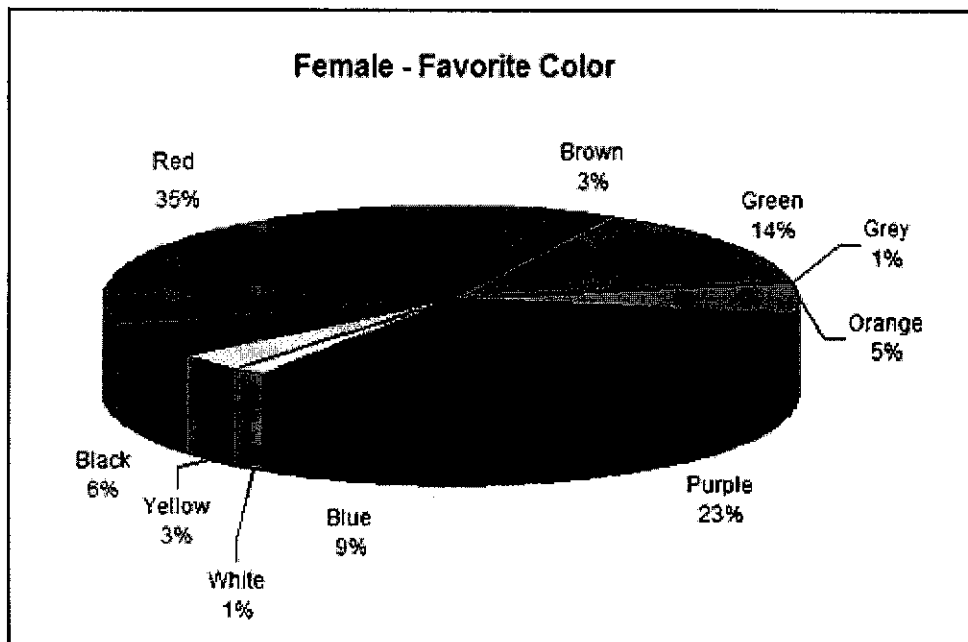

Figure 3: Female Favorite Color by Joe Hallock

### **3.1.2.3 Development of Coding Phase**

For code phase, decision tree is applied in managing each question for cancers and diseases. This to help author in doing the coding part whereby by looking at the decision tree it will help in managing questions to be asked from start to end. Decision tree are used in classification clustering methods. Decision tree will break down the problems into discrete subsets, by working from generalization to increasingly more specific information [Yuk, Premme & Raymond, 2005]. It consists of root and followed by internal nodes. Each node will be labeled with question and the arcs cover all possible responses. Each response represents a probable outcome and each response represents value in indicating the result of the questionnaire later.

Decision tree also use in determining question that relate to each other. This is because, not all questions going to be displayed at the same time. There are certain questions that need further questions to be asked in determining the depth of information of user.

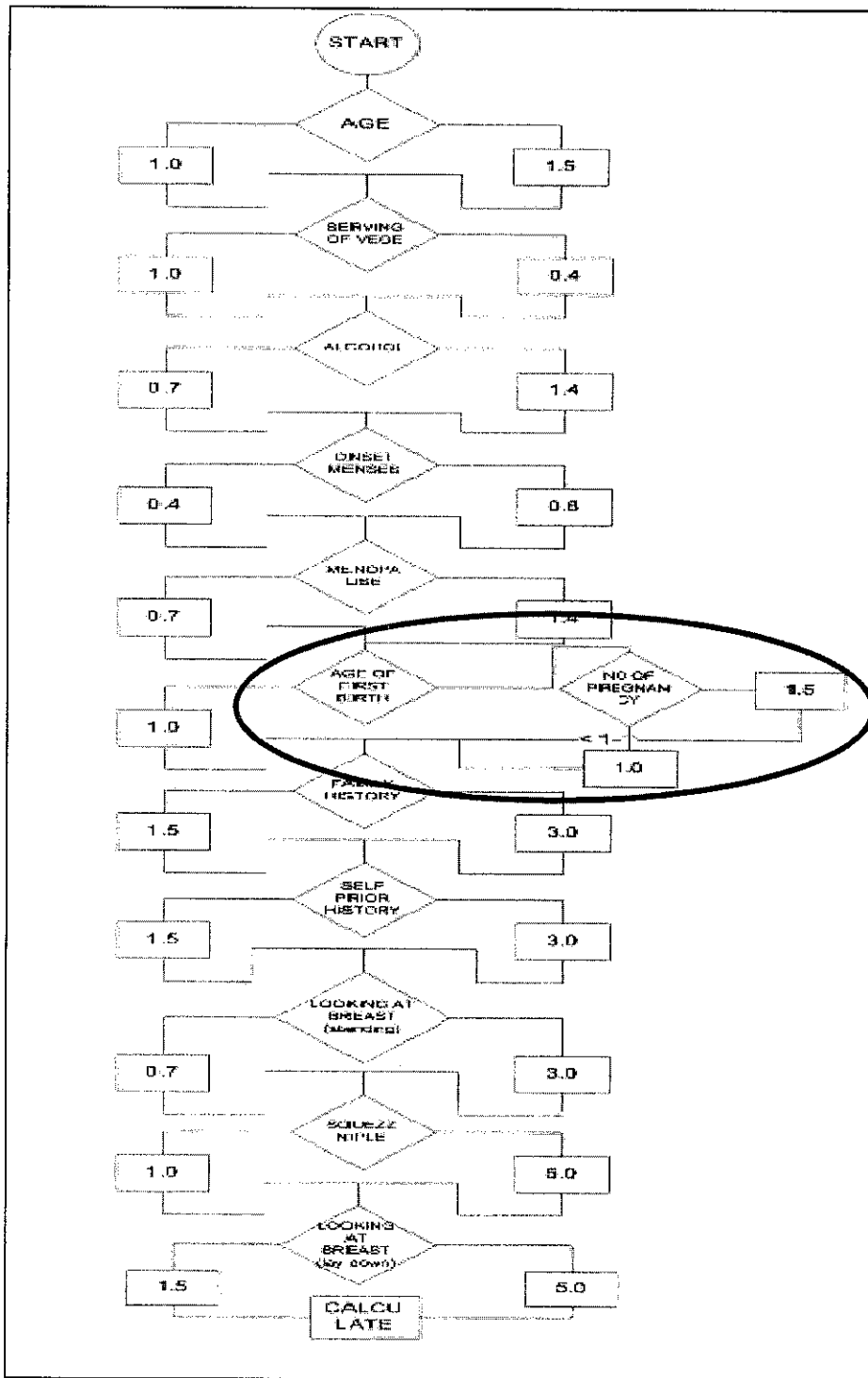

Figure 4: Flow chart of Breast Cancer Question

#### **3.1.2.4 Testing Phase**

Test phase is very important and need to be done to ensure the system is completely done and the contents are accurate and can be execute by user. It also to ensure the user friendliness of the system thus, feedback from user was gathered. As for this stage the system the evaluator are divided into two categories, which are gynecologist and also novice user. This is because the target user of the system is among this people thus, the testing phase will ensure the strength of the system.

As for the testing that has been conducted among gynecologist, the only factors that need to be evaluated are the questions available in the web page and also the flow of questions. This is to ensure the questions are all importance questions and related to each cancer and disease. Although previously, confirmation have been done, but later testing also need to be viewed by the gynecologist to ensure the system is safe to be used by user. During the testing, author and gynecologist are sitting to each other, and questions were viewed from one to another. This is to ensure all of the terms use, way of asking the questions and the options of answered are all correct and ready to be use by user. As for the result of the testing, no changes need to be done, thus system is maintained as it is and the testing among novice users is ready to be conducted.

Evaluations sheet refer to Appendix I, are made as for the testing phase among novice users. This is because, during the testing phase, author did not sit or available around user while the testing was conducted. This is to ensure user will put all the efforts and use all the functionality that available in the system rather than asking to author. Factors that had been concern for the testing are consist of four factors, which are:



✓ **Interface Design**

Include the appropriate use of colors, the look and feel of the system and also the graphics available in the system.

✓ **Navigation**

It is important for users to know where they are during browsing or using the system. This is achieved through proper use of headings for each page and also buttons that link users to other topic available in the system. The evaluation of navigation will prove whether the navigation buttons are easy to understand and use.

✓ **Text**

Web page are viewed at different machines, thus there are only a few sets of fonts that can be guaranteed to be available. As for this site, verdana was used as the dominant font because research have been done, and as referred to human computer and interaction procedures suggested font is verdana with the font size of 10 [Neal, 2005].

✓ **Use of Language**

The common flaw in web developer is grammatical errors, thus author has proofread the site. This is to ensure that such errors were not made. Users also have been asked to check and mark if any grammatical errors in the site to be sited in the evaluation sheets. Not only that, user also were asked to state if any terms that use in the system that is not familiar and hard to find the definition.

A few changes had been made due to the responses that have been given by the evaluator. Detailed description of the evaluation's result can be found in the Results Chapter.

## 3.2 Apparatus

### 3.2.1 Software

In developing this system, open source software is used which is Macromedia Dreamweaver. This software is chosen because Dreamweaver is the industry-leading web development tool, which enabling users to efficiently design, develop and maintain standards-based websites and applications. Furthermore, the knowledge that author have in applying the functions that available in developing websites using this software because the software had been cover in the course syllabus and this give more confident and opportunity in enhancing the skills by applying it in developing the system.

Language that use in implementing the system is Personal Home Page (PHP). This is because PHP is one of the most popular server side scripting languages running today [Rasmus, Kevin, 2004]. It is used for creating dynamic web pages that interact with the user offering customized information. PHP also offers many advantages whereby it is fast, stable, secure, easy to use and open source. PHP code is inserted directly into the HTML that makes up a website. When a visitor comes to the website, the code is executed. PHP is a server side technology thus, user does not need any special browser or plug-ins to see the PHP.

Other software that have been used is Microsoft Visio for creating models using object oriented analysis such as use case diagram and decision tree of questionnaire. Adobe Photoshop has been used to do the interface design of the system, whereby the logo of Online Women Self-Health Check System and button had been design.

### 3.2.2 Hardware

Hardware that used for tasks and activity that involve in developing the web-based system are:

1. Intel Pentium 4 2.2 GHz
2. MSI 845E Max motherboard
3. Kingston 256MB DDR RAM
4. Samsung LCD monitor 17"
5. Samsung Keyboard
6. Logitech Optical Mouse
7. Pen drive 512MB

### 3.2.3 Process Flow

In retrieving information from user and the process of manipulating the input to achieve the output or result, set of questions on symptoms of each cancer and diseases need to be answered by users. User need to perform the self-checked by following the steps given and after each step is done user need to select the answer of each questions. After all the questions were answered by user, results of the diagnosis will appear according to the techniques mentioned earlier which is decision trees.

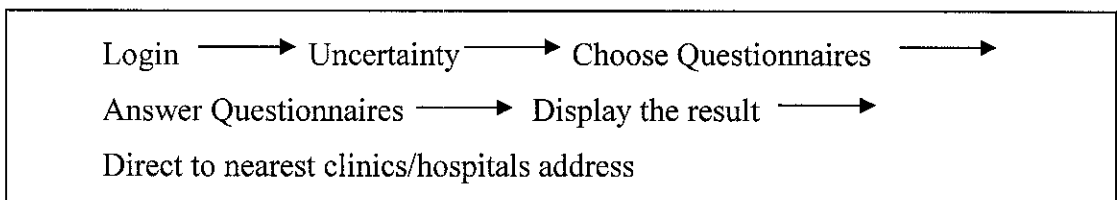

Figure 5: Process of Manipulating Input for Output

## **CHAPTER 4**

### **RESULT AND DISCUSSION**

#### **4.1 RESULTS**

As mentioned in the requirements and analysis phase, there were series of interviews conducted with gynecologist and also surveys that had been done among University Technology Petronas's students. All of the activities really important in implementation of Online Women Self-Health Check System and the outcome of all of the activities were positive and beneficial to the project.

##### **4.1.1 Interview**

In order to gather information, besides from medical books and browsing health sites, interview with gynecologist is very important in ensuring the entire information gathering is true and related to the symptoms. Prior to that, author had done twice interview with the gynecologist whereby the first interview was conducted at the earlier research of project implementation and the second interviews during the testing phase.

As for the first interview, the aim is to know the perception of specialist on the implementation of the project. Their views and comments are very vital in ensuring that the project is reasonable to be implemented. Besides that, as refer to the research that had been made by author earlier, all of the information is gathered and arrange accordingly and had been shown to the gynecologist. This is to ensure that all of the information that has been gathered is all importance in the determination of the high, medium and low risk of cancers and diseases. All of the symptoms

have been arranged in number according to each cancer and diseases refer page Appendix H.

After 10 interviews had been conducted from different gynecologist, a few changes had been reached in term of symptoms that related to cancers and diseases. Some of the symptoms that had been gathered by author is not really important and should be omitted and some should be included in. As the end results for breast cancer there are 12 questions all together in order to get the level of risk, for cervical 10 questions, menopause eight, migraine 12 and depression 12.

### 4.1.2 Questionnaires

Another source of information gathering was questionnaire that was contributed among University Technology Petronas's female students and also women in the age of 25 and above. A total number of 100 questionnaires had been distributed as referred to the Quantitative Method Principles, which advise to select a sample of forty subjects and above if thorough results are to obtain from the sample [Curwin, 2002]. The main aim of the questionnaire was to gain user perspective in two important factors, which are:

✓ **User Awareness on Cancers in Malaysia**

The aim is to know the current knowledge and awareness of women in Malaysia regarding the percentage of death among women that related to cancers. Actions that had been taken by them also had been asked in the questionnaires whereby it is useful for author in determining the awareness of women toward breast check and cervical check.

✓ **The Need of Online health System**

As for being in this era, everything needed to be done fast and on the spot. People do not want to waste time and thus, author has come up with the idea of making the system online. In the questionnaire also, author seek for user opinion about system that can help them in doing self-examination online and their frequency in browsing health webpage.

✓ **Favorite Color**

As for the interface design reason, author has included questions in determining color that is user's favorite. However the range of colors that available in the questionnaires is the same as the research that had been done by Joe that had mentioned in methodology chapter. This is just for additional surveys in ensuring that the design of the system is going to be attractive and love to be used by users.

The results of each factor that had been asked to users have been arranged accordingly in the form of graph below.

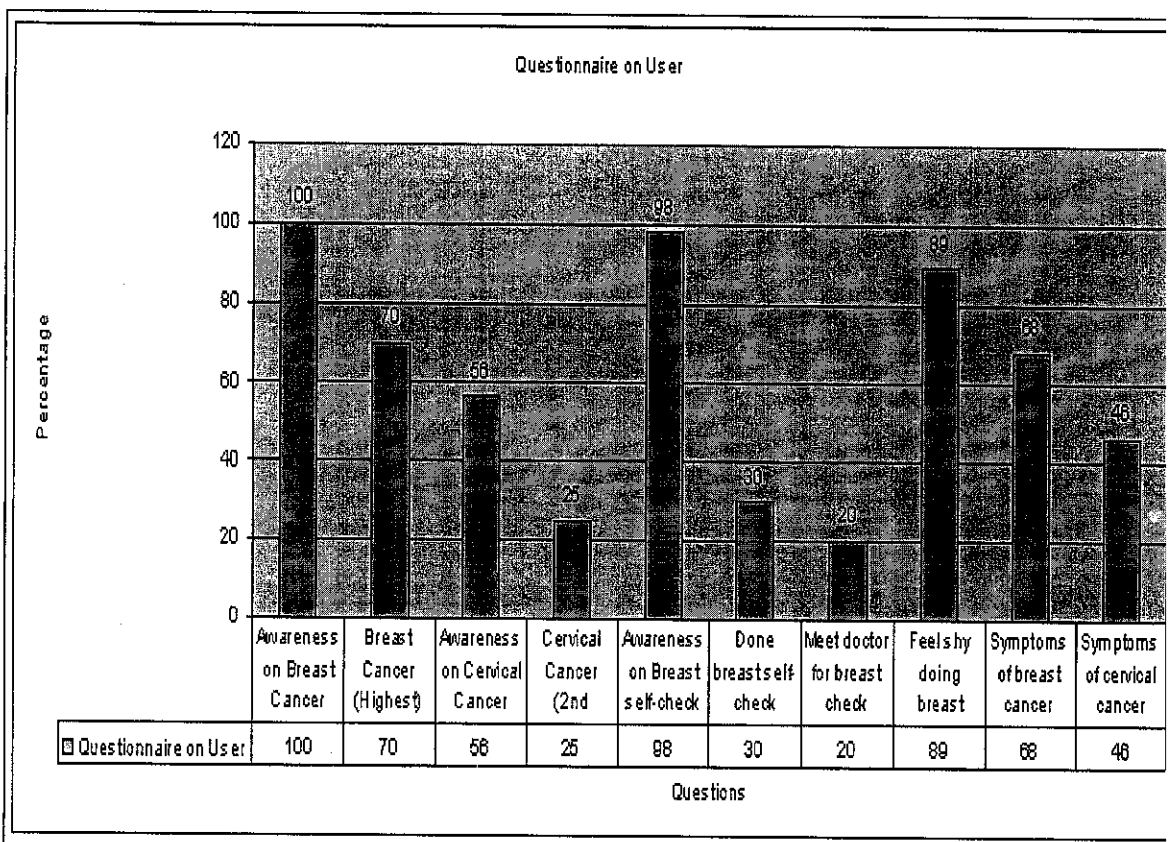

**Figure 6: Results for Questionnaire**



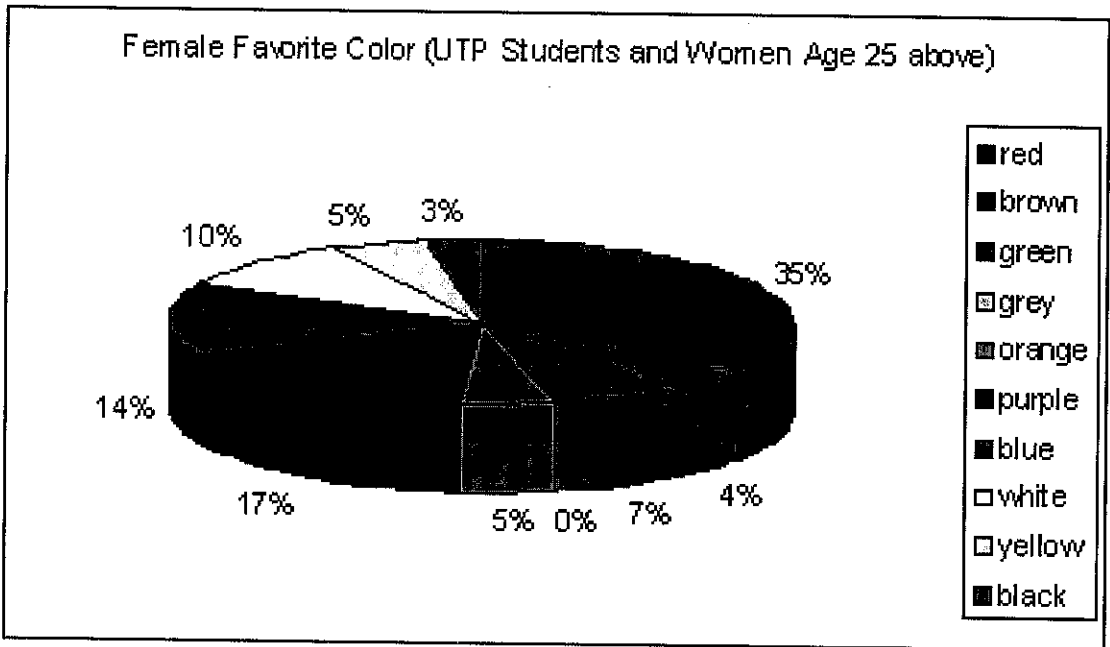

**Figure 7: Female Favorite Color – Author’s survey**

### 4.1.3 Heuristic Evaluation Sheets

The evaluators who were involved in the evaluation were observed through out the evaluation. The main factors that important in doing the evaluations toward the system are on the interface design, navigation, text and use of language.

Responses base on above concern had been received as refer to the **Figure 8**. Overall, the evaluator was impressed with the design and flow of the system. It is easy to use and adopt the user friendliness concept.

Some of the comments that have been received are in term of the terms use in the system that are said to be a bit professional rather than using simpler terms and also the font size that is said a bit smaller thus, changes had been made in meeting all of the comments. This is to ensure that the system is fulfilling all user requirements and easy for users to use.

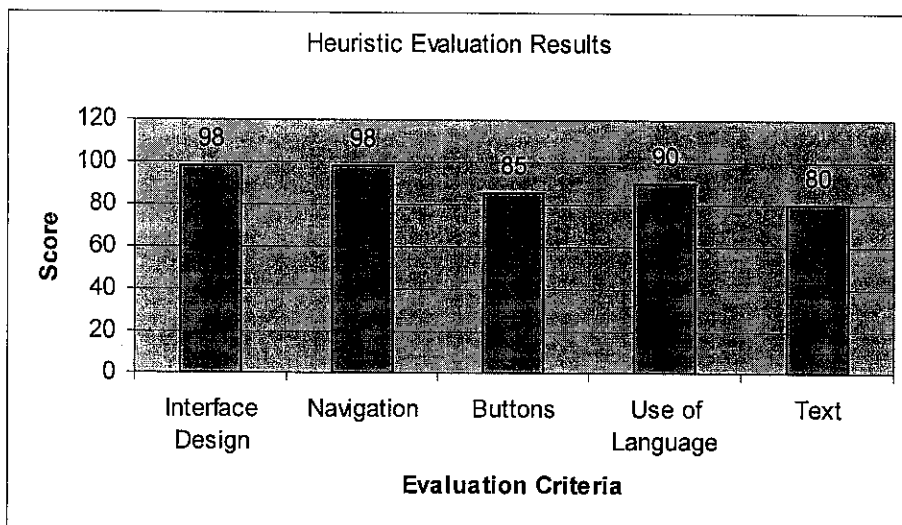

**Figure 8: Heuristic Evaluation Result**

## 4.2 DISCUSSION

### 4.2.1 Online Women Self-Health Check System

All users need to sign up as members in order to use the system. The reason of the activity is to ensure the postcode of user's can be kept in database and the nearest hospital that situated to user's area can be displayed. Furthermore, details of individual are kept to ensure later enhancement of the website can be manipulated by using user's details that had been provided earlier. Recommendation of the system will be explained later in this chapter.

Existence of Online Women Self-Health Check System, really help women in dealing with curiosity. By just following steps and answering questions that had been arranged, user will get the results of level of risk for each cancers and diseases immediately. After signing up, user can use the system as many times as they like and can start answering questions based on the two cancers and three diseases that available in the webpage.

By having the privilege, user can make breast check as a habit for every month after four days of premenstrual. Government and ministry of health also encourage women in doing own self examination specially in doing breast examination. When this becomes a habit, something that earlier feel difficult by users won't be the same again. This is because, self-examination is not difficult to do, furthermore by having the steps provided user just had to follow the instructions.

Once user use the system, at first user may feel confuse on the condition and choices that have been provided, but then during the second month and beyond user will compare the earlier condition to the current and this is when actually the self-check really help. During the interview that had been done with all the specialist

and gynecologist, all of them had mentioned that it is actually a good change that should be taken by all women which is doing self-examination. This is because breast check is not something that should be done once in every three years but monthly thus, it encourage all women to know how breast check is conducted and make it as a habit in life.

After all of the questions and steps have been answered by user than straight away the results of level of risks and nearest location of clinic and hospital will be displayed. The objective of this is to ensure that user realize the level of risks that they were at that point. Then, it will at least create a sparks for them to actually take extra cautions in life and change life style if appropriate.

Screen-shot of Online Women Self Health Check System starting from signing up, result of level of risk and user signing out can be viewed in Appendix J.

### 4.3 RECOMMENDATION

Due to the time constraint, there are some elements that cannot be included in the system. There are a few recommendations for the enhancement of the system in order for better functionality of the system.

The first recommendation is to make Online Women Self Health Check System available in making online appointment to clinic and hospital. By having this element it make the system more user friendly whereby user straight away can make appointment and check for availability for further checkup. However, collaboration between clinic and hospital need to be achieved to ensure databases can be connected, manage and retrieve every second of everyday.

Beside that, author also recommend further enhancement in term of result storage, whereby user can view back result that have been answered previously. This functionality allow user to track and compare the results and encourage user for healthier lifestyle. This is because, user must be terrified in comparing result and thus, make them plan for healthy lifestyle each day.

The scope of the system can be broaden to more cancers and diseases rather than focusing on the two cancers. There are more cancers that need attention and alertness of nation nowadays and thus, it should be included in the system.

All of the recommendation will make Online Women Self Health Check System much more attractive and reliable to all potential users.

## **CHAPTER 5**

### **CONCLUSION**

There are five objectives of the research and all of have been met. The technical considerations such as the development of the system have been done. The non-technical factors such as potential user's responses, content required and other also were researched.

The system was developed with the intent of overcoming the problem that has been faced by women nowadays. It also had been a major concern by the government and also ministry of health. This is because percentage of women having breast cancer and cervical cancer increasing each day thus, something got to be done to ensure the percentage is decreasing.

Research has indicated that large numbers of women feel embarrass in doing diagnosis of breast check and thus, it effects the decision regarding to do it or not. This as a result becomes a stumbling-block in doing examination.

Women should be encouraged and teach to do own self checked. Online Women Self Health Check System has this functionality whereby women can refer to the steps mentioned and response to it in order to get the result and thus, this help women in interacting the problem and share it in a beneficial way. Late detection also may be avoiding because the self checked could be done by women monthly without have to think on other factors.

Other way that had been done in overcoming the issues is by ensuring the system can be accessed by women anytime anywhere because of its web capabilities. There are number of benefits associated with having online system which include offering:

- ✓ **Universal Access:** In order to increase awareness, as well as to accelerate the application existence. This is to ensure all women have the opportunity in interacting their problem and thus, decreasing the percentage of late detection.
  
- ✓ **Offer core issues (cancer):** A common set of core cancer have been made available in the system, which are breast cancer and cervical cancer. Other diseases that have been included are like menopause, depression and migraine.
  
- ✓ **Privacy:** Through this system it creates a sense of privacy that essential for women to comply. Women can do self examination at anywhere they feel comfortable and thus, it is more convenience to them.
  
- ✓ **Database:** A lot of data can be gathered, store and displayed to ensure. As for example, in the system, list of public and private hospitals are available for user. This is to ensure at the end of the usage of the system, user can be suggested to nearest and also other hospitals that located to user's area.

The research was therefore completed within the allocated time frame but with certain limitation. Only limited number of cancers and functionality could be possibly offered in the system.

The objectives have been met and tested. Thus, the system is ready to use by women and start a new chapter in life whereby making self-check as a habit in life. The Online Women Self Health Check System has the potential of contributing effectively to women worldwide. It is pleasing to know that the author has contributed to this initiative, no matter how small the contribution is.

*“You know yourself better than others.”*

– **Professor Suzanne Garland**, clinical microbiologist and sexual health physician from the Royal Women’s Hospital, Australia.



## REFERENCES

1. Beaumont Andy, Stephens Jon & James Jon, Ullman Chris (2002), "*Usable Forms for the Web*", page 400
2. Branchers, D.E (2001) "*Communication and Uncertainty Management*", page 477 – 497
3. Bruno R. Preiss (1999) "*Data Structures and Algorithms with Object-Oriented Design*", page 203
4. David A. Lash (2003) "*The Web Wizard Guide To PHP*" page 215-260
5. Dr Alex E Delikan (2000) "*The Female Patient*" page 1 – 3
6. Efraim Turban, Jay E. Aronson & Ting Peng Liang (2005) "*Decision Support System and Intelligent Systems*" page 165-180
7. "*Giving a Pap Talk*" [online]  
[thestar.com.my/services/printerfriendly.asp?file=/2005/9/28/health/12136488.asp](http://thestar.com.my/services/printerfriendly.asp?file=/2005/9/28/health/12136488.asp&sec=health)  
&sec=health, (accessed Wed Sept 28, 2005)
8. Joe Hallock (2005) "*Color Assignment Preferences - Favorite Color*" [online]  
[joehallock.com/edu/COM498/preferences.html](http://joehallock.com/edu/COM498/preferences.html), (accessed Wed 21 Dec, 2005)
9. Joseph B. Walter (2005) "*Attributes of Interactive Online Health Information Systems*" page 7-30
10. Justine Scott-Macnab(2002) "*Reader's Digest Good Health Fact Book – A Safer Home and A Safer World*" page 315
11. Koselleck, R. (1985) "*Future Past : On the Semantics of Historical Time*" page 111-130

12. Lee Gomes (2002) "*Effectiveness of Online System for virtualization*" page 145
13. "*Macromedia Dreamweaver Tutorial*" [online]  
[www.macromedia.com/support/dreamweaver/tutorial\\_index.html](http://www.macromedia.com/support/dreamweaver/tutorial_index.html) (accessed Wed 1 Feb, 2006)
14. Maricon Williams (2005) "*Woo your Viewers through Colors*", [online]  
[www.articlealley.com/article\\_46354\\_4.html](http://www.articlealley.com/article_46354_4.html), (accessed Wed 21 Dec, 2005)
15. Mesman, J (2002) "*Experienced Pioneers : Dealing with Doubt in the Intensive Care for Neonates*" page 512-530
16. Neal Starkman (2005) "*The Wonders of Interactive Whiteboards*" page 270 - 290
17. Rachna Dhingra Luisita Sarmiento (2003) "*Journal of Health and Social Behavior*" page 8 – 44
18. Rasmus Lerdorf, Kevin Tatroe (2004) "*Programming PHP*" page 1-5
19. Rod Stephens (1998) "*Ready-to-Run Visual Basic Algorithm*" page 88
20. T. Menzies, Y. Hu, "*Data Mining For Very Busy People*" page 18-25.
21. "*Using Analytic Services Data Mining Framework For Classification*" [online]  
[dev.hyperion.com/resource\\_library/white\\_papers/Data\\_Mining\\_WP.pdf](http://dev.hyperion.com/resource_library/white_papers/Data_Mining_WP.pdf) (accessed Sat 24 Feb, 2006)
22. Watts S. Humphrey (2005) "*Managing the Software Process*" page 354-370
23. Yuk Lie Sien, Premme Melville & Raymond Jay Mooney (2005) "*Combining bias and Variance Reduction Techniques for Regression Trees*" page 122 - 145

## Interview

24. Dr. Sarjeet Singh Sidhu (2005, December 26). [Personal interview. MBBS (Amritsar), FRCOG (London) FICS (USA), LLB. Hons. (London), Consultant Obstetrician & Gynaecologist]

Dato' Dr. K. Mahadeva (2005, December 26) [Personal interview. MBBS (Hons) Syd., FRCOG (London), Obstetrician & Gynaecologist]

Dr. Haji Ahmad Adlan (2005, December 27) [Personal interview. MBBS (Amritsar), FRCOG (London) FICS (USA), LLB. Hons. (London), Obstetrician & Gynaecologist]

MR. C. S. NA NAGARA (2005, December 27) [Personal interview. MBBS (Singapore), FRCS (Edin), FRCOG (London), AM (Mal), Obstetrician & Gynaecologist]

Dr. Mrs. Lu Luan (2005, December 28) [Personal interview. MBBS (NSW, Australia), M.R.C.O.G (London), Consultant Obstetrician & Gynaecologist]

Dr. Divakaran (2005, December 28) [Personal interview. MD (USM), M.R.C.O.G (London), Consultant Obstetrician, Gynaecologist & Fetal Medicine]

Dr. Usha Devy Balaguru (2005, December 28) [Personal interview. MD. MOG (UKM), MRCOG (London), Consultant Obstetrician & Gynaecologist]

Dr Nik Ahmad Zuky Nik Lah (2005, December 29) [Personal interview. MBBS (Amritsar), FRCOG (London) FICS (USA), LLB. Hons. (London), Obstetrician & Gynaecologist]

## **APPENDIX A: Project Gantt Chart**

**APPENDIX B: Questionnaire for Target User**

Questionnaires for FINAL YEAR PROJECT (PART B) title  
WOMEN SELF HEALTH CHECK SYSTEM

1. What do you reflect on breast examination?

- Important
- Not necessary
- Only for older people

2. Which one do you prefer? Have your breast check with doctor or by yourself?

- Doctor (go to question 3)
- By myself (go to question 4)

3. Why doctor?

-----  
-----  
-----  
-----

4. Why by yourself?

-----  
-----  
-----  
-----

5. Do you know that the percentage of women having breast cancer increasing each year?

- Yes I aware of that
- I thought so
- Oh really?

6. Do you aware of the symptoms and risk factors of breast cancer?
- Yes
  - Not really (go to question 7)
  - Not at all (go to question 7)
7. Would you like to know about it or any other cancer? (continue from question 6)
- Absolutely
  - Yes
  - No
8. What do you think if there is a website on women self health check that can allow you to do your self examination on cancers and diseases that related to women?
- Good
  - Not necessary
  - Very useful
9. Do you think that the availability of such website crucial for women nowadays?
- Yes
  - Not really
  - Not at all
10. Do you think that such website can help women in dealing with their curiosity or problem?
- Yes
  - Not really
  - Not at all



11. Choose your favorite color

- Red
- Brown
- Green
- Grey
- Orange
- Purple
- Blue
- White
- Yellow
- Black

## **APPENDIX C: Use Case Diagram**

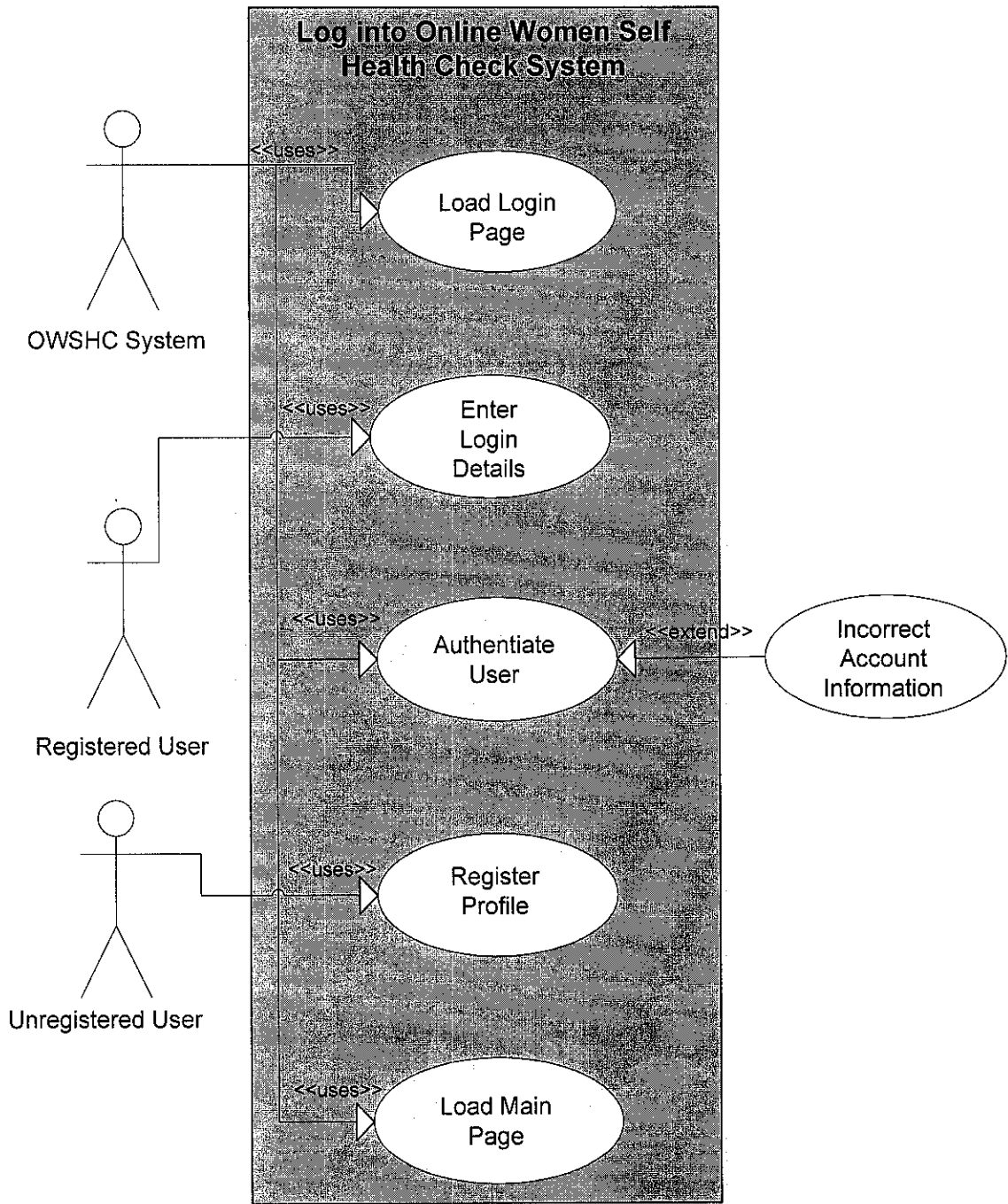

# Registered User Accessibility for Online Women Self Health Check System

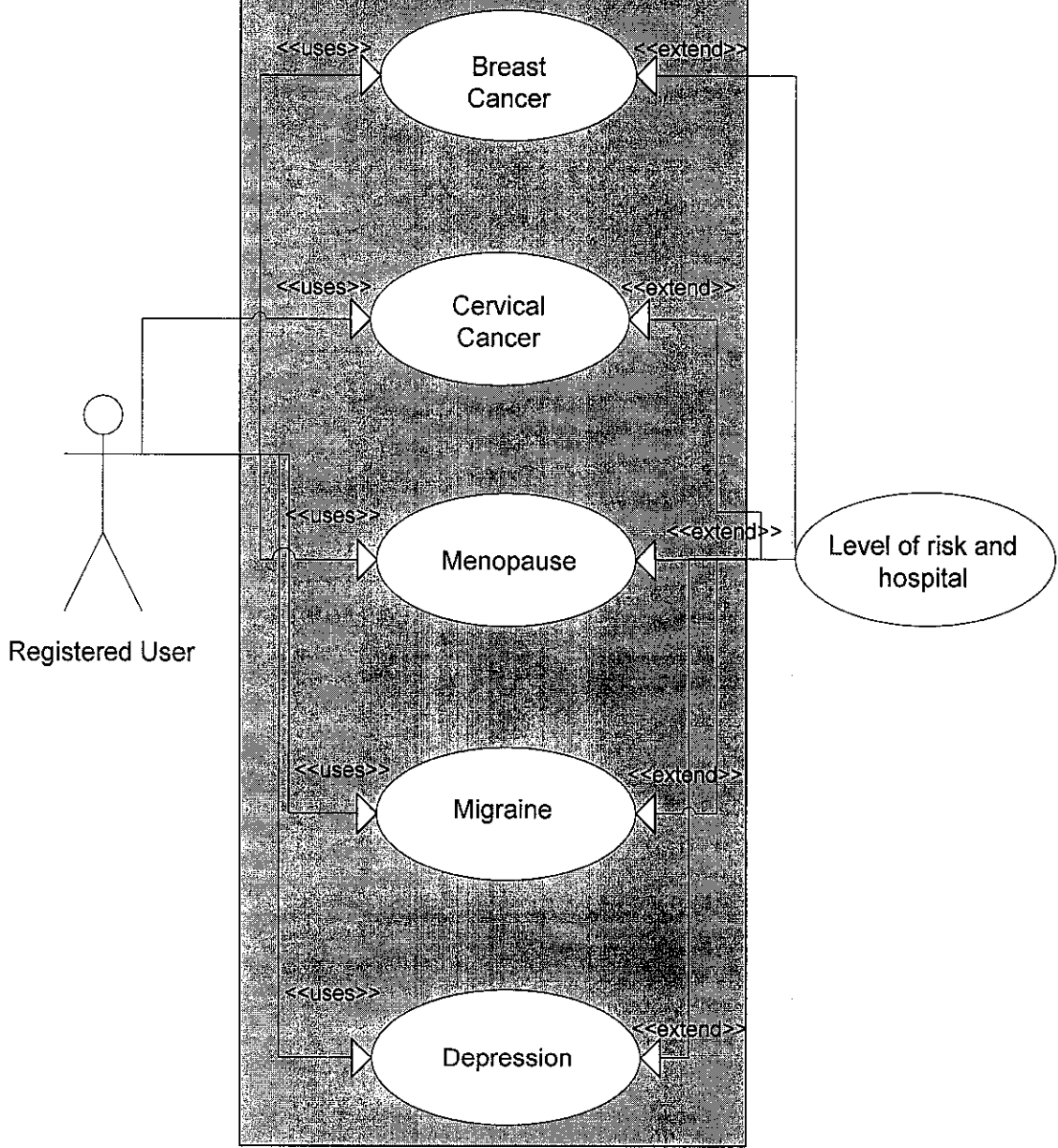

## **APPENDIX D: Data Flow Diagram**

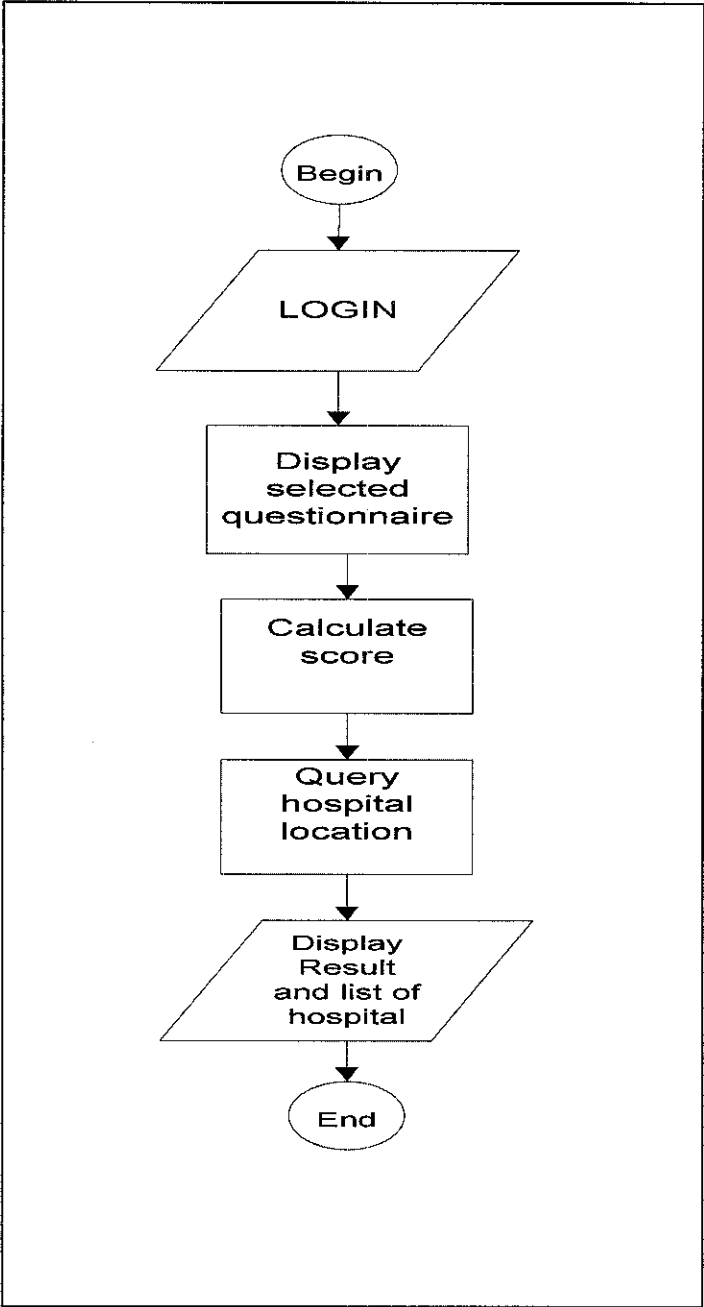

**APPENDIX E: Flow Chart for Breast Cancer**

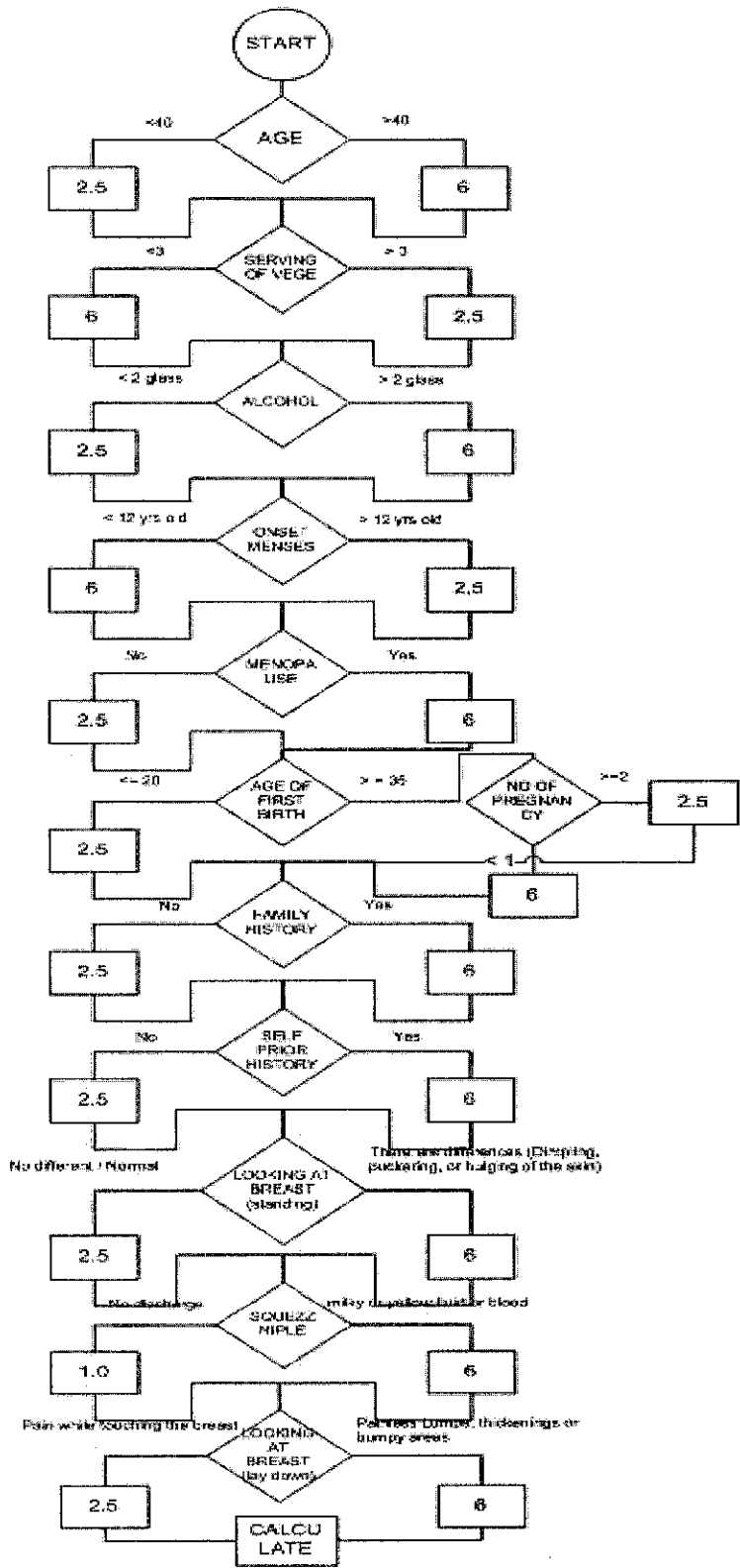



**APPENDIX F: Flow Chart for Cervical Cancer**

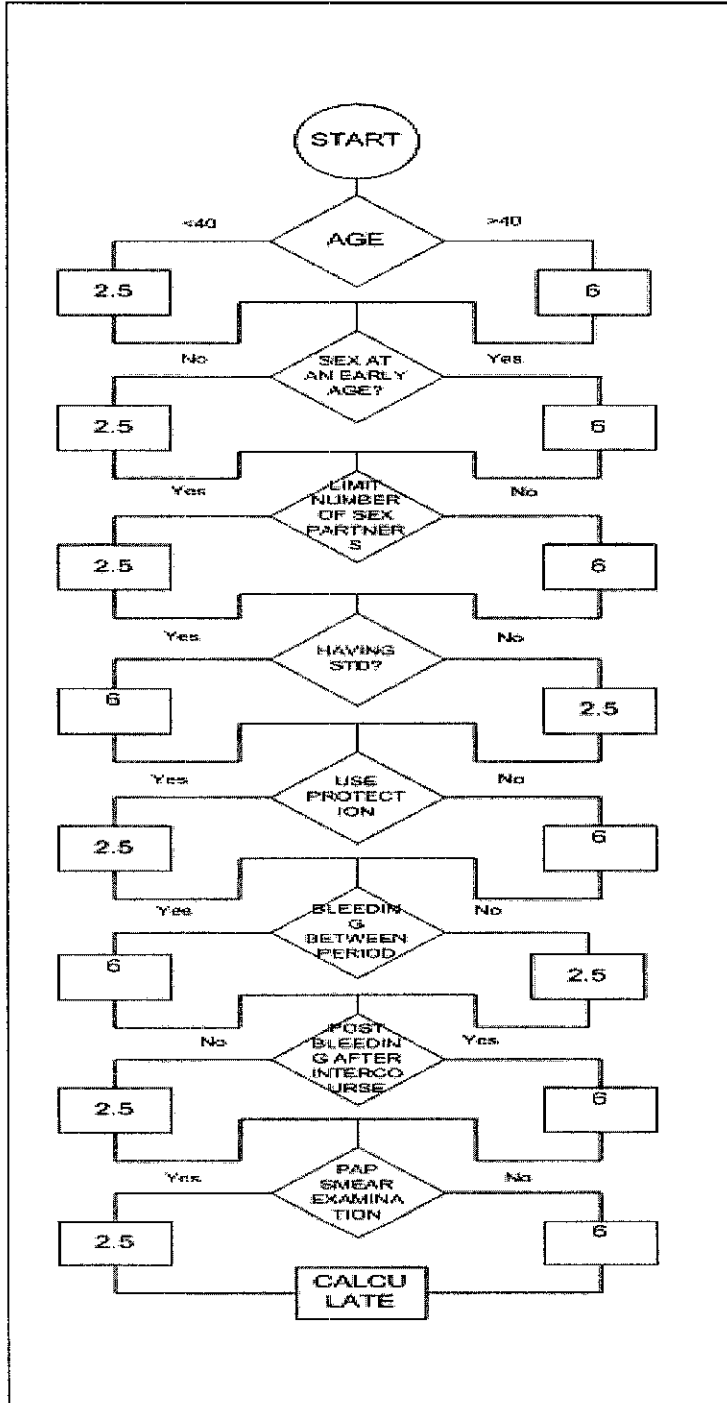

## **APPENDIX G: Project System Architecture**

business process

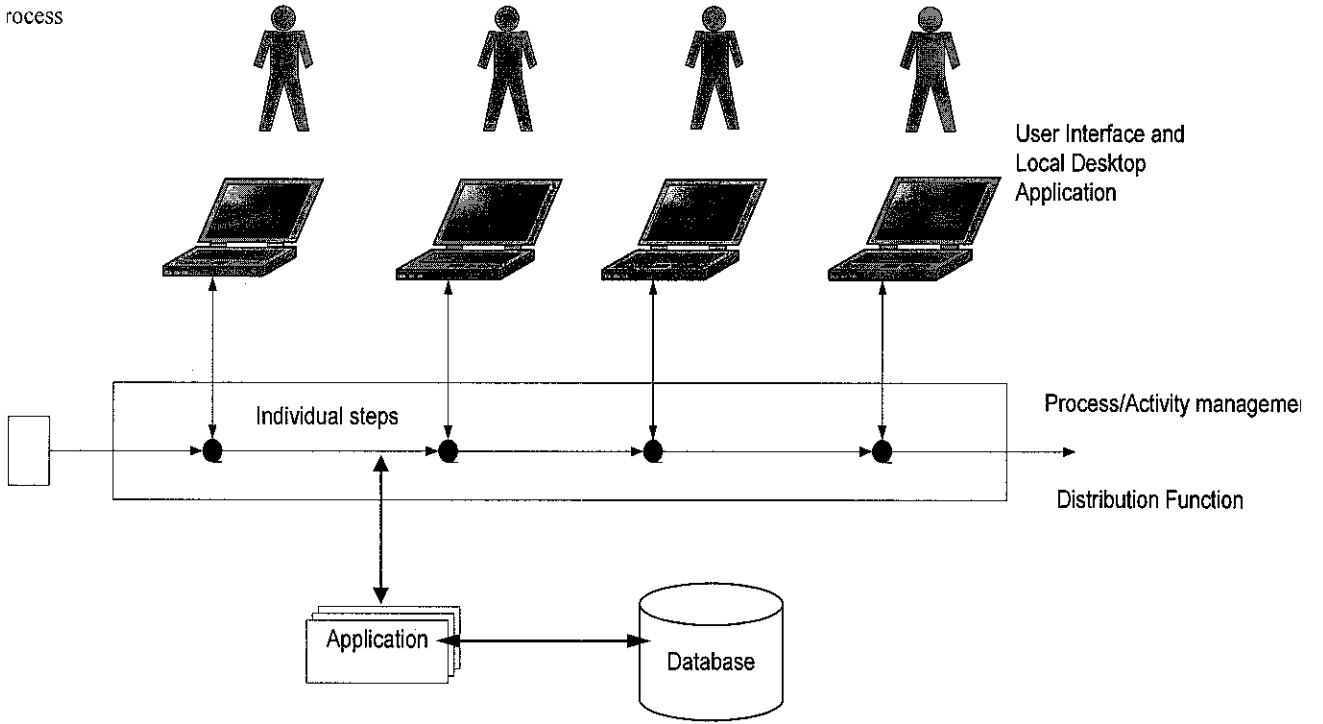

**APPENDIX H: List of Question based on symptoms  
(To be asked to gynecologist)**

## **Breast Cancer**

1. **How old are you?**
  - At age of 40 or below
  - At age of 41 and above
  
2. **Portion of taking vegetables per day?**
  - More than 3 serving vegetables
  - Less than 3 serving vegetables
  
3. **Do you drink alcohol? Whats the portion per day?**
  - Yes. More than 2 glasses of alcohol
  
  - Not at all or less than 2 glasses of alcohol
  
4. **When was your onset of menses**
  - At the age of 12 or below
  
  - At the age 13 and above
  
5. **When was your onset of menses**
  - At the age of 12 or below
  
  - At the age 13 and above
  
6. **Are you having menopause now?**
  - Yes
  
  - No
  
7. **Are you having menopause now?**
  - Yes
  
  - No.

**8. Do you have children(s)?**

- Yes
- No

**9. Number of children?**

- 2 and above
- 1 or None

### **Breast Check**

**10. Begin by looking at your breasts in the mirror with your shoulders straight and your arms on your hips**

- Breasts that are there usual size, shape, and color without visible distortion or swelling.
- Any of this: Dimpling, puckering, or bulging of the skin. A nipple that has changed position or become inverted (pushed inward instead of sticking out). Redness, soreness, rash, or swelling.

**11. Raise your arms and look for the same changes. While you're at the mirror, gently squeeze each nipple between your finger and thumb and check for nipple discharge**

- No discharge
- Milky or yellow fluid or blood

**12. Lying down, feel your breasts using your right hand to feel your left breast and then your left hand to feel your right breast. Use a firm, smooth touch with the first few fingers of your hand, keeping the fingers flat and together. Cover the entire breast from top to bottom, side to side—from your collarbone to the top of your abdomen, and from your armpit to your cleavage.**

- Painless Lumps, thickenings or bumpy areas
- Pain while touching the breast

## **Vaginitis**

- 1. Do u having excessive amount of vaginal discharge?**
  - Yes – During busy day**
  - Yes – All the time**
  - No - Normal**
  
- 2. What is the color of your vaginal discharge?**
  - Thick white, yellow or green and smell like fish**
  - Thick white and yellow with no smell**
  - No color**
  
- 3. How long do you always wearing your tampon?**
  - Less than 4 hours**
  - 4 – 6 hours**
  - More than 6 hours**
  
- 4. Do you experiencing pain during passing urine and sexual intercourse?**
  - Yes – for either one**
  - No**
  
- 5. How is it looked like around your vagina?**
  - Tenderness, irritation and itch in and around the vagina**
  - No irritation and not itchy**



## Menopause

**1. How old are you?**

- 30's below
- Middle of 40's
- Peak of 50's

**2. How do you sleep at night?**

- Disrupted – night sweats, hot flushes
- Soundly (nyenyak)

**3. Irregular periods**

- Yes
- No

**4. How your mood everyday?**

- Mood changes – anxiety, irritability, poor memory, poor concentration, depression, tiredness, headaches
- Energetic

**5. Urinary?**

- Normal, no changes
- Frequently
- Seldom

**6. Physical changes?**

- dry and thin skin, dry hair, loss of hair
- Nothing changes – everything is normal

**7. How your sex life?**

- Painful during sexual intercourse
- Loss of interest in sex
- Have interest in sex

**8. Feeling Emotionally Detached**

- Yes
- No

## Migraine

1. **Have any of your family experiencing migraine?**
  - Yes
  - No
  
2. **Have anything that makes u feel stress lately?**
  - Yes
  - No
  
3. **On average, how many bad headaches do you experience per month?**
  - 1
  - 2-3
  - 4 or more
  
4. **Do you addicted to caffeine or alcohol?**
  - Yes
  - No
  
5. **Do you experience visual disturbance before the head pain kicks in?**
  - Yes - wavy lines, flashing lights, blind spots
  - No - Clear eye sight
  
6. **How long does your headache normally last for?**
  - Less than 4 hours
  - 4 – 24 hours
  - 25 – 48 hours
  - 2 – 4 days
  
7. **Every time you feel dizzy, do u...**
  - feel numbness, thumping or throbbing headache
  - Pain on one side (may swap sides), feel like to vomit
  - Can control the dizziness
  
8. **Do u always feel dehydrate or thirsty?**
  - Yes
  - No

**9. Do you experience sensitivity to light, sounds or smells during these headaches?**

- Yes – either one**
- No**

**10. Does your speech become muddled?**

- Yes**
- No**

**11. Does movement make the head pain worse?**

- Yes**
- No**

## **Depression**

Over the last 2 weeks, how often have you been bothered by any of the following problems?

**1. Little interest or pleasure in doing things.**

- Not at all
- Several days
- More than half the days
- Nearly every day

**2. Feeling down, depressed, or hopeless**

- Not at all
- Several days
- More than half the days
- Nearly every day

**3. Trouble falling asleep, staying asleep, or sleeping too much**

- Not at all
- Several days
- More than half the days
- Nearly every day

**4. Feeling tired or having little energy**

- Not at all
- Several days
- More than half the days
- Nearly every day

**5. Poor appetite or overeating**

- Not at all
- Several days
- More than half the days
- Nearly every day

**6. Feeling bad about yourself, feeling that you are a failure, or feeling that you have let yourself or your family down**

- Not at all
- Several days
- More than half the days

Nearly every day

**7. Trouble concentrating on things such as reading the newspaper or watching television**

Not at all

Several days

More than half the days

Nearly every day

**8. Moving or speaking so slowly that other people could have noticed. Or being so fidgety or restless that you have been moving around a lot more than usual**

Not at all

Several days

More than half the days

Nearly every day

**9. Thinking that you would be better off dead or that you want to hurt yourself in some way**

Not at all

Several days

More than half the days

Nearly every day

**10. How difficult have these problems made it for you to do your work, take care of things at home, or get along with other people?**

Not at all

Several days

More than half the days

Nearly every day

## **APPENDIX I: Heuristic Evaluation Sheet**

Name:

Programme:

Please indicate your selection by mark as (X) in the relevant section

Use the evaluation sheet after done using the system.

	Pleasing to the eye	Moderate	Inappropriate
Interface Design			
	Very Clear	Moderate	Small
Text			
	Understandable	Moderate	Hard to understand
Use of Language			
	With ease	Moderate	Difficult
Navigation			
	Clear	Moderate	Inappropriate
Buttons			

**APPENDIX J. ONLINE WOMEN SELF HEALTH CHECK SYSTEM  
SCREEN SHOTS**



...WELCOME... - Microsoft Internet Explorer

File Edit View Favorites Tools Help

Back Stop Home Search Favorites Media Print Mail

Address http://localhost/fyp/LOGIN.php Go Links Norton AntiVirus

# WOMEN SELF HEALTH CHECK SYSTEM

---



Be our member and get the benefit!  
 Have you ever feel shame to see doctor? Think that not everything can be shared? wonder who can answer your curiosity...so join and we can help you to answer it!

NOTE: This guide is not intended as a substitute for medical advice. You must agree to our terms of use in order to use this website

**LOGIN**

**EMAIL:**

**PASSWORD:**

**REGISTER**

Done Local Intranet

Landing Page - Login

WOMEN SELF HEALTH CHECK SYSTEM



Be our member and get the benefit!  
Have you ever feel shame to see doctor? Think that not everything can be shared? wonder who can answer your curiosity...so join and we can help you to answer it!

NOTE: This guide is not intended as a substitute for medical advice. You must agree to our terms of use in order to use this website.

Incorrect User Name or Password

**LOGIN**

EMAIL:

PASSWORD:

**REGISTER**

Internet

Incorrect user id or password

Microsoft Internet Explorer window showing a member registration page. The browser title is "...JOIN AND GET YOUR BENEFIT...". The address bar shows "http://localhost/fyp/personal.php".

The page content includes a header: "SIGNUP AND HAVE ALL THE CURIOSITY BEEN ANSWERED!" and a sub-header: "You can begin using this site right after you finish entering your details..".

On the left side, there is a logo featuring a female symbol with the text "self check" inside the circle.

The registration form fields are:

- First Name :
- Last Name :
- Date of Birth :  date  month  year
- Gender :  Male  Female  
(This site was build specially for women)
- State :  Choose..
- Postal Code :
- Email :   
(This is going to be your login id)
- Password :   
Max 6 characters
- Re-enter Password :   
Max 6 characters

A "Register" button is located below the form fields.

The status bar at the bottom shows "Done" and "Local Intranet".

Member Registration Page

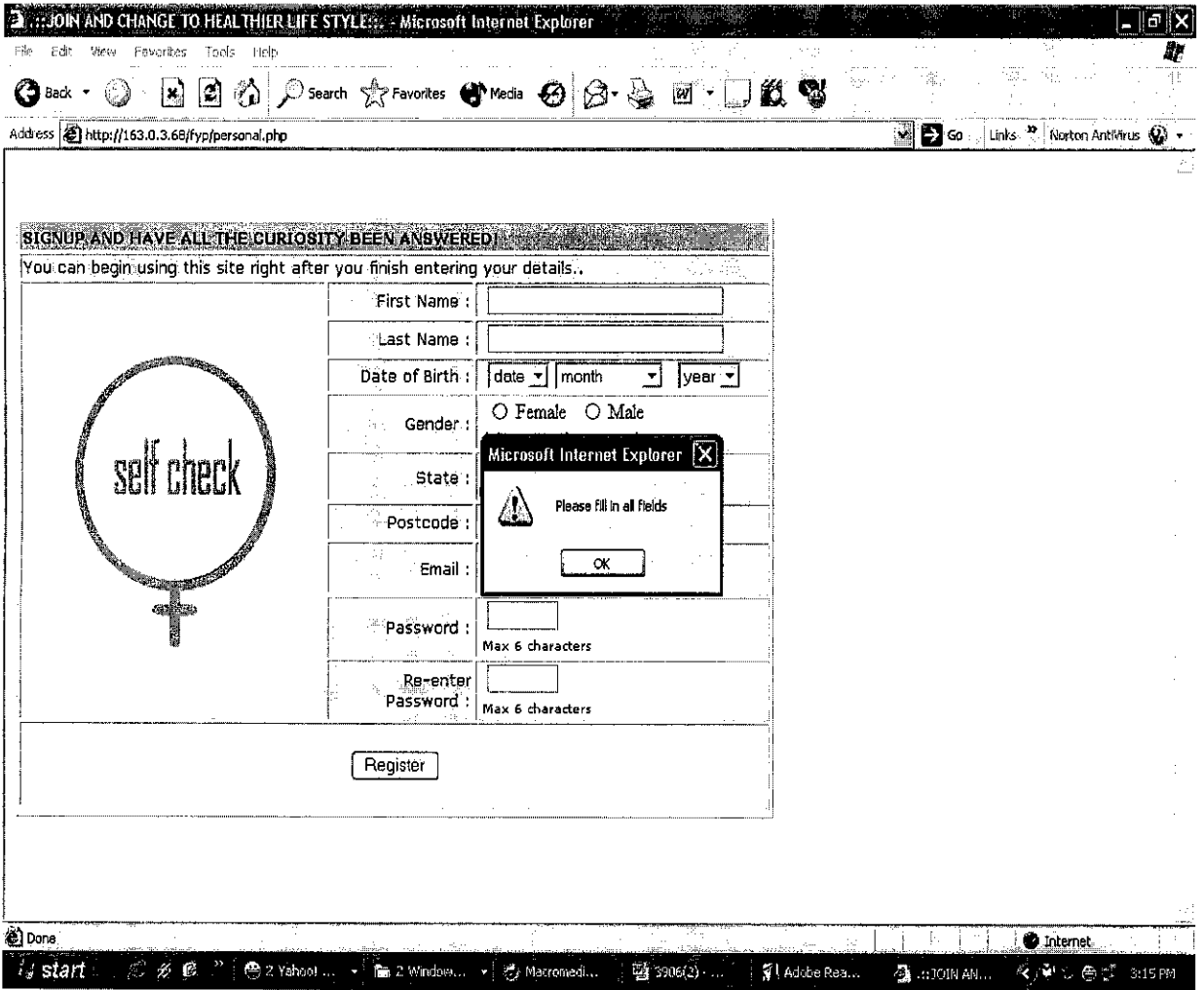

Pop-up message appear if no fields are entered or any missing fields

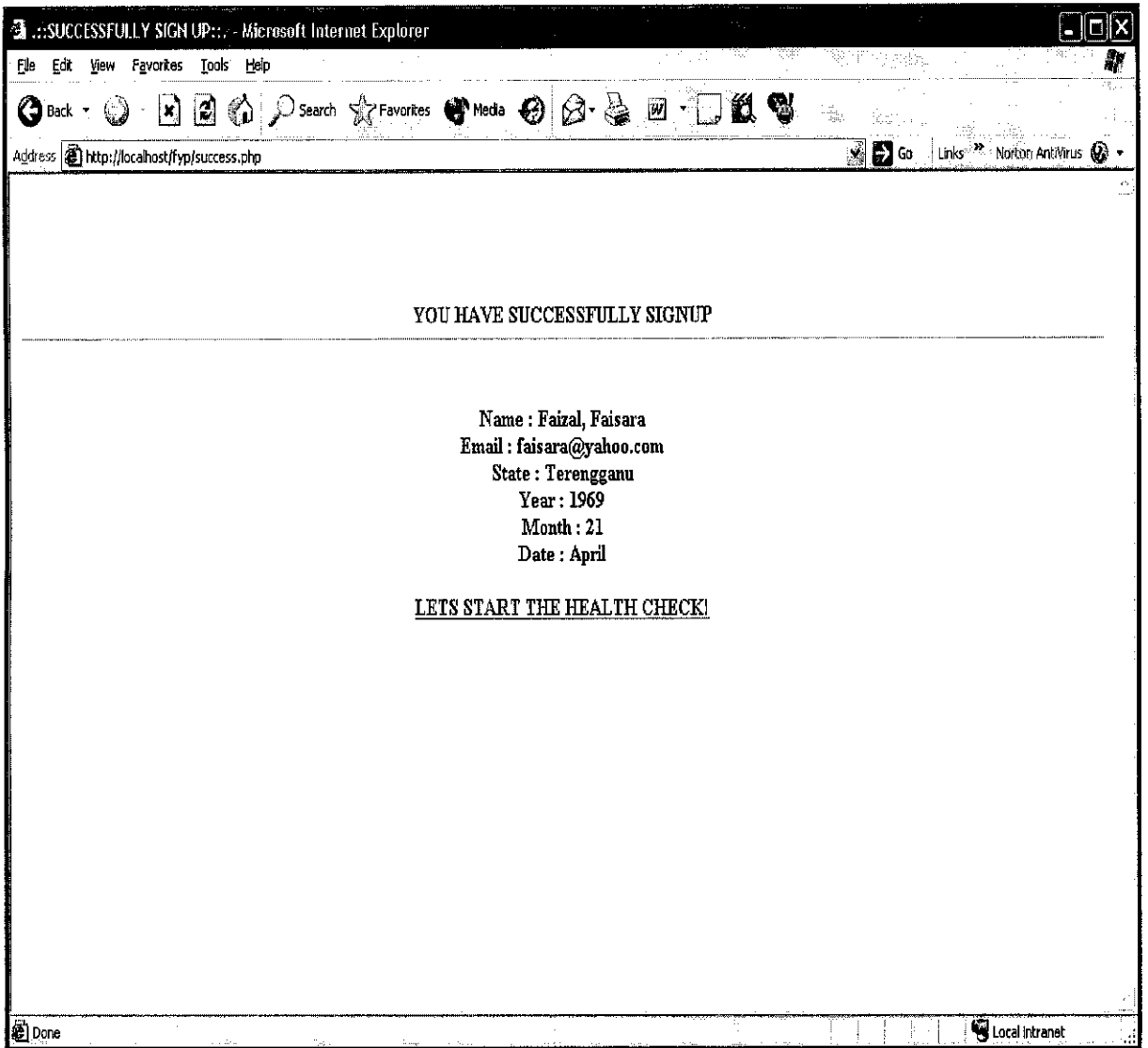

## Confirmation Details

... START IT TODAY ... - Microsoft Internet Explorer

File Edit View Favorites Tools Help

Back Stop Refresh Home Search Favorites Media Print Mail W

Address http://localhost/fyp/index.php Go Links Norton AntiVirus

# WOMEN SELF HEALTH CHECK SYSTEM

 **WELCOME**  
Mas

- Depression
- Fatigue
- Breast Cancer
- Cervical Cancer
- Menopause
- Depression
- Migraine



**Welcome to WOMEN SELF HEALTH CHECK SYSTEM**  
the source for prevention.

Here You can find out your risk of developing  
**FIVE** of the most important diseases among  
women in **MALAYSIA**. LETS GET STARTED....  
**PICK ONE OF THE CHOICES ON THE LEFTSIDE**  
**AND LET THE CURIOSITY BEEN ANSWERED!**  
**PREVENTION IS BETTER THAN CURE!!**

Done Local intranet

First Page of Online Women Self Health Check System

Microsoft Internet Explorer  
 Address: http://localhost/fyp/breast.php

# WOMEN SELF HEALTH CHECK SYSTEM

self check **WELCOME**  
Mas

- Endometriosis
- Endometrial Cancer
- Breast Cancer**
- Cervical Cancer
- Menopause
- Depression
- Migraine

**Breast Cancer**

Do you know that each year, there are more than 500 new cases of breast cancer in Malaysia? And that 45% of patients are in the end-stage?

The earlier breast cancer is detected, the better the chance of complete cure! YOU can help safeguard your health by making a habit of examining your breast once a month - a day or two after your period or, if you are no longer menstruating, on any given day.

Many women do not feel confident enough about doing the examination right. Others feel it would make them worry needlessly. Both these excuses are silly! After a few months of regular examination, you will become familiar with the contours of your breast and you will know exactly what is normal for you.

Then if you notice anything changed or unusual - a lump, thickening or discharge - CONTACT YOUR DOCTOR RIGHT AWAY!

Assign Question

Done Local Intranet

## Breast Cancer Information

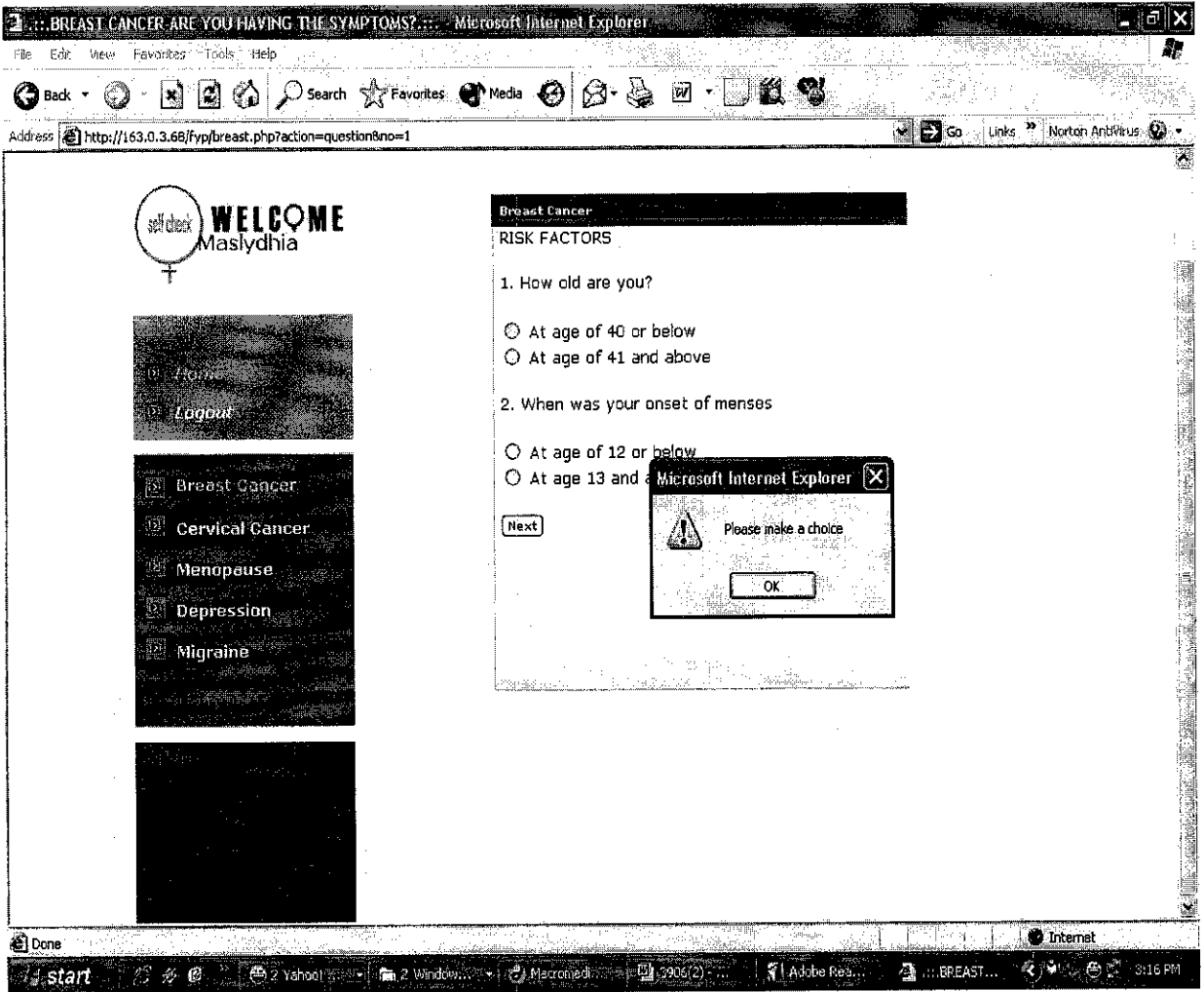

Pop-up message appear if no fields are entered or any missing fields



Microsoft Internet Explorer window showing a web page titled "BREAST CANCER-ARE YOU HAVING THE SYMPTOMS?...". The address bar shows the URL: http://163.0.3.68/fyp/breast.php?action=question&no=1.

The page content includes a navigation menu on the left with the following items:

- Home
- Logout
- Breast Cancer
- Cervical Cancer
- Menopause
- Depression
- Migraine

The main content area displays a "Breast Cancer" section with the following "RISK FACTORS":

1. How old are you?

- At age of 40 or below
- At age of 41 and above

2. When was your onset of menses

- At age of 12 or below
- At age 13 and above

A "Next" button is visible below the second question.

## Breast Cancer Questions

... BREAST CANCER-ARE YOU HAVING THE SYMPTOMS?... - Microsoft Internet Explorer

File Edit View Favorites Tools Help

Back Search Favorites Media

Address http://localhost/fyp/breast.php?action=question&no=9

# WOMEN SELF HEALTH CHECK SYSTEM

self check WELCOME Mas

- Home
- Report
- Breast Cancer
- Cervical Cancer
- Menopause
- Depression
- Migraine

**Breast Cancer**

Dear : Mas

Total Result : 50  
 <- High Risk ->

You are very much above average risk. You have to see a doctor as soon as possible and have your breast check by them now!! There are many risk factors of breast cancer in you. It doesn't mean you'll definitely get cancer. Breast examination is important for women to do it monthly. Only then you can notice the difference of it. Make it as a habit and do it after your menstruation! It will help you a lot in noticing the existence of the lump! HOWEVER, healthy lifestyle and diet also can minimize the risks! So eat balance diet and spend some time to exercise!

The information contained on this site is provided for educational purposes only and is not intended to replace discussions with a healthcare provider

No	Hospital Name	Hospital Address	Hospital Phone	Link
1	HUKM	111, Jalan Sultan Azlan Shah, 50450 Kuala Lumpur	03-23762626	<a href="http://www.hukm.ukm.my">www.hukm.ukm.my</a>

List Print

Done Local Intranet

Example of result that will appear according to level of risk and the nearest hospital to user's location

...BREAST CANCER-ARE YOU HAVING THE SYMPTOMS?... - Microsoft Internet Explorer

File Edit View Favorites Tools Help

Back Search Favorites Media

Address http://localhost/fyp/breast.php?action=question&no=10



1. Home

2. Login

3. Breast Cancer

4. Cervical Cancer

5. Menopause

6. Depression

7. Migraine

### List Of Hospital

Hospital No	Hospital Name	Hospital Address	Hospital Phone	Link
1	Hospital Kuala Lumpur	100, Jalan Raja Chulan, Kuala Lumpur	03-2060-5555	<a href="http://www.hkl.gov.my">www.hkl.gov.my</a>
2	Hospital Putrajaya	20, Jalan P. Ramlee, Putrajaya, Kuala Lumpur	03-888-8000	<a href="http://www.i-putra.com/hpj">www.i-putra.com/hpj</a>
3	Hospital Ampang	1, Jalan Ampang, Ampang, Kuala Lumpur	03-4970-2500	<a href="http://www.ampangputeri.com.my">www.ampangputeri.com.my</a>
4	Hospital Seremban	100, Jalan Sultan, Seremban, Negeri Sembilan	06-9070-4033	None
5	Hospital Kajang	100, Jalan Kajang, Kajang, Selangor	03-8720-0033	None
6	Hospital DSH	100, Jalan DSH, DSH, Kuala Lumpur	03-4070-8000	<a href="http://www.dsh.com.my">www.dsh.com.my</a>
7	Hospital GIMC	100, Jalan GIMC, GIMC, Kuala Lumpur	03-4230-1000	<a href="http://www.gimc.com.my">www.gimc.com.my</a>
8	Hospital HSC	100, Jalan HSC, HSC, Kuala Lumpur	03-2042-9866	<a href="http://www.hsc.com.my">www.hsc.com.my</a>
9	Hospital Pantar	100, Jalan Pantar, Pantar, Pahang	06-2250-8888	<a href="http://www.pantar.com.my">www.pantar.com.my</a>
10	Hospital Pusrawi	100, Jalan Pusrawi, Pusrawi, Kuala Lumpur	03-4080-8222	<a href="http://www.pusrawi.com.my">www.pusrawi.com.my</a>

Done Local Intranet

List of all government and private hospital in user's state

...CERVICAL CANCER-SECOND LEADING CAUSE OF DEATH FOR WOMEN...DO YOU KNOW THAT?... - Microsoft Internet Explorer

File Edit View Favorites Tools Help

Back Home Stop Search Favorites Media Mail Print Print Preview

Address: http://localhost/fyp/servical.php

# WOMEN SELF HEALTH CHECK SYSTEM

self check WELCOME Mas

- Home
- Logout
- Breast Cancer
- Cervical Cancer
- Menopause
- Depression
- Migraine

### Cervical Cancer

Do you know that after breast cancer, cervical cancer is the second leading cause of death for women. The death rate of this type of cancer is 12% .Cervical cancer is caused by a virus called human papillomavirus (HPV). HPV causes cells in the cervix to grow out of control and become cancerous.Please aware that this virus can be passes from one another that means that if your partner having sex with women that have this virus then it can be high percentage of you to have it too!!So watch your partner...

The cervix is part of the female reproductive system. It's about one inch around and connects the vagina to the uterus (womb). Sparm travels through the cervix to fertilize a woman's egg during conception.

When start having sex, all women should be screened for cervical cancer regularly. The screening test is called a Pap smear. Getting regular Pap smears is the single best way to lower your risk of cervical cancer. The test can find abnormal cells, which can later be removed before they turn into cancer. This screening can only be done by doctor but we can prevent it by knowing the risk factors and symptoms of cervical cancer!Ready?

Assign Question

Local Intranet

## Cervical Cancer Information

... CERVICAL CANCER-SECOND LEADING CAUSE OF DEATH FOR WOMEN..DO YOU KNOW THAT?... - Microsoft Internet Explorer

File Edit View Favorites Tools Help

Back Search Favorites Media

Address: http://localhost/fyp/serviceal.php?action=question&no=1

# WOMEN SELF HEALTH CHECK SYSTEM

self check WELCOME Mas

- Home
- Logout
- Breast Cancer
- Cervical Cancer
- Menopause
- Depression
- Migraine

### Cervical Cancer

RISK FACTORS

1. How old are you?

At age of 40 or below

At age of 41 and above

2. Do you have your sex at an early age?

Yes

No

Done Local intranet

Cervical Cancer Questions

Menopause - Microsoft Internet Explorer

File Edit View Favorites Tools Help

Back Search Favorites Media

Address http://localhost/fyp/menopausee.php

# WOMEN SELF HEALTH CHECK SYSTEM

 **WELCOME**  
Mas

- 1. Home
- 2. Logout
- 3. Breast Cancer
- 4. Cervical Cancer
- 5. Menopause
- 6. Depression
- 7. Migraine

**Menopause**

THE menopause is a natural event that occurs in all women. It is the permanent cessation of periods (menstruation) as a result of the loss of activity of the ovaries and can only be said to have occurred only after 12 consecutive months without spontaneous menstruation .

Physical and other changes occur in the years leading up to the menopause. Most of the changes are normal and are related to the menopause. Others are more related to ageing and may, in some women, be associated with illness, as many conditions that are not related to the menopause e.g. hypertension; diabetes, obesity, etc. are diagnosed about the time of the menopause.

Each woman's experience of the menopause is unique . For some, the end of menstruation brings about freedom from concerns about fertility. For others, it is a time of coping with social changes that are inevitable during this time when the children begin to leave home.

For a few, it is about dealing with illness . For the vast majority, the menopause is a new part of life when they report empowerment, increased confidence and renewed vigour than when they were younger. It is also an opportunity to improve the quality of life with improved health practices.

Assign Question

Local intranet

## Menopause Information

Menopause - Microsoft Internet Explorer

File Edit View Favorites Tools Help

Back Search Favorites Media

Address http://localhost/fyp/menopausee.php?action=question&no=1

# WOMEN SELF HEALTH CHECK SYSTEM

self check WELCOME Mas

- Breast Cancer
- Cervical Cancer
- Menopause
- Depression
- Migraine

**Menopause**

**RISK FACTORS**

1. How old are you?

- 40s below
- Between 40s and 50s

2. How do you sleep at night?

- Disrupted - night sweats, hot flushes
- Soundly Asleep

Done Local intranet

Menopause Questions

...DEPRESSION OR IS IT JUST NORMAL ME?... - Microsoft Internet Explorer

File Edit View Favorites Tools Help

Back Search Favorites Media

Address http://localhost/fyp/depression.php

# WOMEN SELF HEALTH CHECK SYSTEM

self check **WELCOME**  
Mas

- Breast Cancer
- Cervical Cancer
- Menopause
- Depression
- Migraine

**DEPRESSION**

The following DEPRESSION QUESTIONNAIRE has 10 simple questions that may help identify common symptoms of depression. The results can be a helpful way to discuss your condition with your healthcare provider and actually help them diagnose your condition.

After answering the questions provided on the following pages, print the completed questionnaire and discuss any concerns with your doctor. As with any medical illness or condition, only your doctor or other qualified healthcare professional can provide a diagnosis of depression. The following questionnaire is intended to help you discuss symptoms with a qualified healthcare professional.

This questionnaire is not intended to serve as a substitute for a diagnosis of depression by a qualified healthcare professional. You should visit your doctor or other qualified healthcare professional as soon as possible if you think you may have depression. Complete the questionnaire below and take the results to your doctor for further diagnosis!

Assign Question

Local intranet

## Depression Information



DEPRESSION or IS IT JUST NORMAL ME? ... - Microsoft Internet Explorer

File Edit View Favorites Tools Help

Back Search Favorites Media

Address http://localhost/fyp/depression.php?action=question&no=1

# WOMEN SELF HEALTH CHECK SYSTEM

self check WELCOME Mas

Program

- Breast Cancer
- Cervical Cancer
- Menopause
- Depression
- Migraine

### Depression

RISK FACTORS

1. Little interest or pleasure in doing things.

- Not at all
- Several days
- More than half the days
- Nearly everyday

2. Feeling down, depressed, or hopeless

- Not at all
- Several days
- More than half the days
- Nearly everyday

Next

Done Local Intranet

## Depression Questions

Migraine - Microsoft Internet Explorer

File Edit View Favorites Tools Help

Back Home Search Favorites Media Print

Address http://localhost/fyp/migraine.php

# WOMEN SELF HEALTH CHECK SYSTEM

self check WELCOME Mas

- 1. HOME
- 2. LOGIN
- 3. Breast Cancer
- 4. Cervical Cancer
- 5. Menopause
- 6. Depression
- 7. Migraine

Migraine

It's estimated that 1 in 10 people experience migraine and yet many don't realise that this common condition is the cause of their suffering. If you are to find effective relief, it is important to get an accurate diagnosis. Although there are no medical tests that can detect the presence of migraine, your doctor will use a checklist of questions to confirm whether or not you are one them who suffer from migraine. This questionnaire is not intended to serve as a substitute for a diagnosis by a qualified healthcare professional but it is done by referring to the symptoms of migraine!

Assign Question

Local intranet

Migraine Information

Migraine - Microsoft Internet Explorer

File Edit View Favorites Tools Help

Back Stop Search Favorites Media

Address http://localhost/fyp/migraine.php?action=question&no=1

# WOMEN SELF HEALTH CHECK SYSTEM

self check WELCOME Mas

- Home
- Log out
- Breast Cancer
- Cervical Cancer
- Menopause
- Depression
- Migraine

### Migraine

RISK FACTORS

1. Have any of your family experiencing migraine?

Yes

No

2. Have anything that makes u feel stress lately?

Yes

No

Done Local intranet

Migraine Questions